

30A Avg.

60 Volts

SBD

FCH30U06

■最大定格 Maximum Ratings

Item	Symbol	Conditions	Unit
くり返しピーク逆電圧 Repetitive Peak Reverse Voltage	$V_{RRM}$	60	V
平均整流電流 Average Rectified Forward Current	$I_O$	50Hz, 正弦全波, 抵抗負荷 50Hz Full Sine Wave, Resistance Load	30 A
実効順電流 R.M.S. Forward Current	$I_F(RMS)$	33.3	A
サージ順電流 Surge Forward Current	$I_{FSM}$	200 50Hz正弦全波, 1サイクル, 非くり返し 50Hz Full Sine Wave, 1cycle, Non-repetitive	A
動作接合温度範囲 Operating Junction Temperature Range	$T_{jw}$	-40~+150	°C
保存温度範囲 Storage Temperature Range	$T_{stg}$	-40~+150	°C
締付トルク Mounting torque	$F_{tor}$	推奨値 Recommended Value	0.5 N·m

■OUTLINE DRAWING(mm)

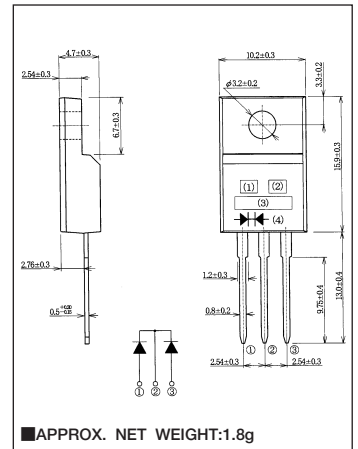

■電氣的・熱的特性 Electrical/Thermal Characteristics

Item	Symbol	Conditions	Min.	Typ.	Max.	Unit
ピーク逆電流 Peak Reverse Current	$I_{RM}$	$T_j=25^{\circ}C, V_{RM}=V_{RRM}$ , 一素子あたり Per Diode	—	—	1	mA
ピーク順電圧 Peak Forward Voltage	$V_{FM}$	$T_j=25^{\circ}C, I_{FM}=15A$ , 一素子あたり Per Diode	—	—	0.69	V
熱抵抗 Thermal Resistance	$R_{th(j-c)}$	接合部・ケース間 Junction to Case	—	—	1.5	°C/W
	$R_{th(c-f)}$	ケース・フィン間 Case to Fin	—	—	1.5	°C/W

■定格・特性曲線

FIG.1

順電圧特性  
FORWARD CURRENT VS. VOLTAGE

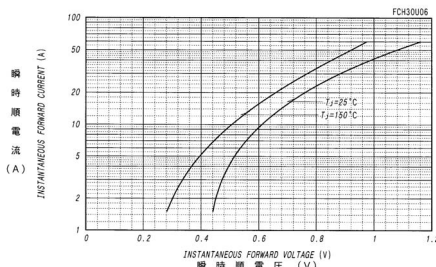

FIG.2

平均順電力損失特性  
AVERAGE FORWARD POWER DISSIPATION

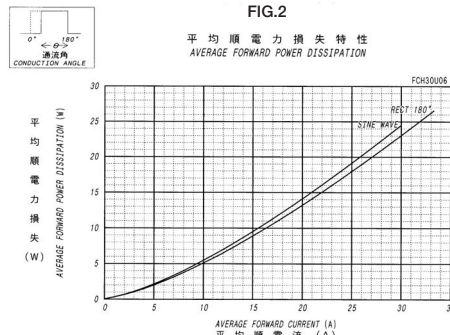

FIG.3

ピーク逆電流 - ピーク逆電圧特性  
PEAK REVERSE CURRENT VS. PEAK REVERSE VOLTAGE

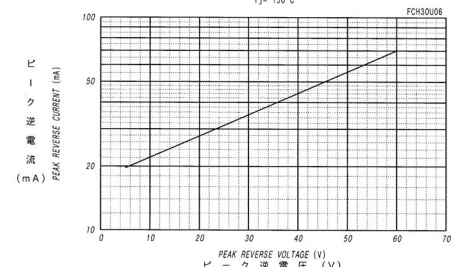

FIG.4

平均逆電力損失  
AVERAGE REVERSE POWER DISSIPATION

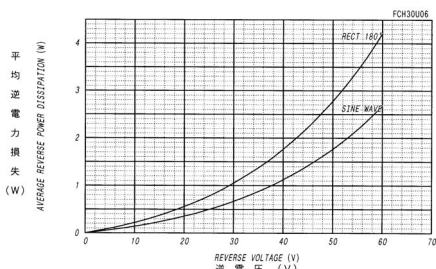

FIG.5

平均順電流 - ケース温度定格  
AVERAGE FORWARD CURRENT VS. CASE TEMPERATURE

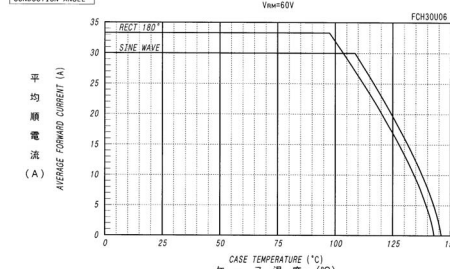

FIG.6

サージ順電流定格  
SURGE CURRENT RATINGS

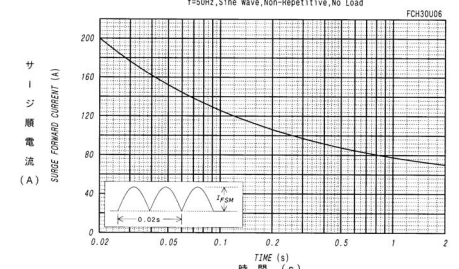

FIG.7

接合容量特性  
JUNCTION CAPACITANCE VS. REVERSE VOLTAGE

