

AZ DISPLAYS, INC.

COMPLETE LCD SOLUTIONS

SPECIFICATIONS FOR LIQUID CRYSTAL DISPLAY

PART NUMBER:

ACM1602Z

REVISED:

OCTOBER 22, 2002

Record of Revisions

DATE	REVISED NO.	REF. PAGE	SUMMARY
10/22/2002	1	3/14	COG IC changed from Fuji Electric (FCS2314AK) to Novatek (NT7605)

AZ DISPLAYS, INC.

1. MECHANICAL DATA

(1) Product No.	ACM1602Z
(2) Module Size	65.0 (W)mm x 27.7 (H)mm x MAX2.0 (D)mm (W/O B.L.)
(3) Dot Size	0.55 (W)mm x 0.60 (H)mm
(4) Dot Pitch	0.60 (W)mm x 0.65 (H)mm
(5) Number of Characters	16 (W) x 2 (H)
(6) Duty	1/16
(7) LCD Display Mode	STN: <input type="checkbox"/> Gray Mode <input type="checkbox"/> Yellow Mode <input type="checkbox"/> Blue Mode FSTN: <input type="checkbox"/> Black and White(Normal White/Positive Image) <input type="checkbox"/> Black and White(Normal Black/Negative Image) Rear Polarizer: <input type="checkbox"/> Reflective <input type="checkbox"/> Transflective <input type="checkbox"/> Transmissive
(8) Viewing Direction	<input type="checkbox"/> 6 O'clock <input type="checkbox"/> 12 O'clock <input type="checkbox"/> ____O'clock
(9) Backlight	W/O
(10) Weight	6.8 g (approx)
(11) Controller (COG)	NT7605

2. ABSOLUTE MAXIMUM RATINGS

(1) ELECTRICAL ABSOLUTE RATINGS

VSS=0V

	SYMBOL	MIN	MAX	UNIT	COMMENT
Power Supply for Logic	VDD-VSS	-0.3	5.5	V	
Input Voltage	VI	-0.3	VDD	V	
Static Electricity	-	-	-	-	Note 1

Note 1 LCM should be grounded during handling

(2) ENVIRONMENTAL ABSOLUTE MAXIMUM RATINGS

ITEM	OPERATING		STORAGE	
	MIN.	MAX.	MIN.	MAX.
Ambient Temperature	-20	70	-30	80
Humidity (Without Condensation)	Note 2,4		Note 3,4	

Note 2 : Ta \leq 50°C : 85%RH max
 Ta>50°C : Absolute humidity must be lower
 than the humidity of 85%RH at 50°C

Note 3 : Ta at -20°C will be < 48hrs, at 70°C will be < 120 hrs

Note 4 : Background color will change slightly depending on ambient temperature.
 This phenomenon is reversible.

3. ELECTRICAL CHARACTERISTICS

(VDD=5.0V ± 10%)

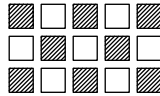
ITEM	SYMBOL	CONDITION	MIN.	TYP.	MAX.	UNIT	
Input Voltage	VIH	H level	0.8VDD	—	VDD	V	
	VIL	L level	0	—	0.2VDD	V	
Recommended LCD Driving Voltage	VDD-V5 (VLCD)	DUTY= 1/16 Bias= 1/5	0°C	4.9	5.1	5.3	V
			25°C	4.7	4.9	5.1	
			50°C	4.6	4.8	5.0	
Power Supply Current	IDD	VDD = 5.0V 	—	1.2	2.0	mA	

4. OPTICAL CHARACTERISTICS

AT Vop

ITEM MODE		Cr(Contrast Ratio)						θ (Viewing Angle)		ϕ (Viewing Angle)			
		0°C		25°C		50°C		25°C		25°C			
		MIN.	TYP.	MIN.	TYP.	MIN.	TYP.	MIN.	TYP.	MIN.	TYP.		
R	A	-	4.5	-	5.0	-	4.0	-	29-24	-	±99		
Note		NOTE 6						NOTE 5					

NOTE :

R : Reflective

A : Gray , 6 O'clock

AT $\phi=0^\circ$ $\theta=0^\circ$

ITEM	SYMBOL	CONDITION	MIN.	TYP.	MAX.	UNIT	NOTE
Response Time (rise)	Tr	0°C	520	570	620	ms	NOTE 2
		25°C	130	150	170		
		50°C	60	80	100		
Response Time (fall)	Tf	0°C	250	300	350	ms	NOTE 2
		25°C	50	70	90		
		50°C	10	30	50		

(NOTE 1)

Definition of Operation Voltage(V_{op})

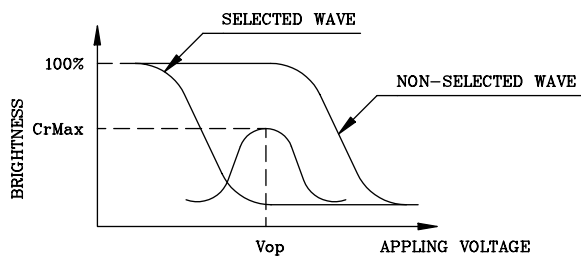

(positive type)

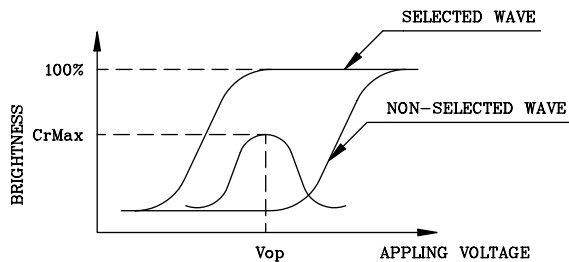

(negative type)

*Conditions

Viewing Angle : 0
 Frame Frequency : 70Hz
 Applying Waveform : I/N duty 1/a bias

(NOTE 2)

Definition of Response Time(T_r, T_f)

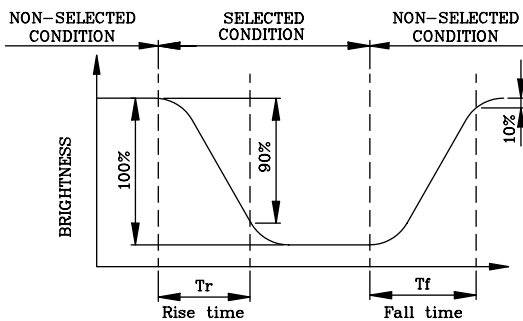

(positive type)

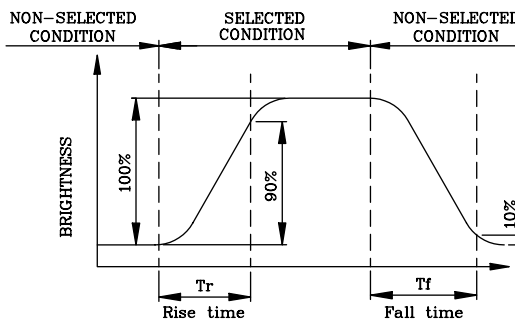

(negative type)

*Conditions

Operating Voltage : V_{op}
 Viewing Angle (θ, θ) : (0,0)
 Frame Frequency : 70Hz
 Applying Waveform : I/N duty 1/a bias

(NOTE 3)

Description of Measuring Equipment and Driving Waveforms

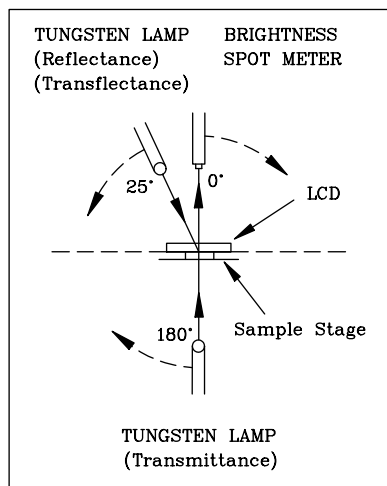

CONST.
 TEMP.
 CHAMBER

Multiplex Driving (I/N duty 1/a bias)

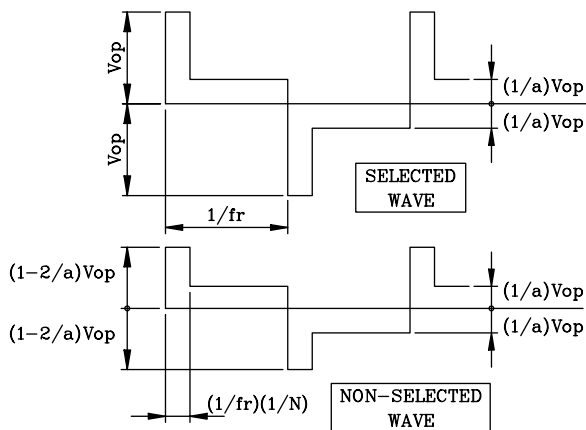

(NOTE 4)

Definition of Viewing Direction

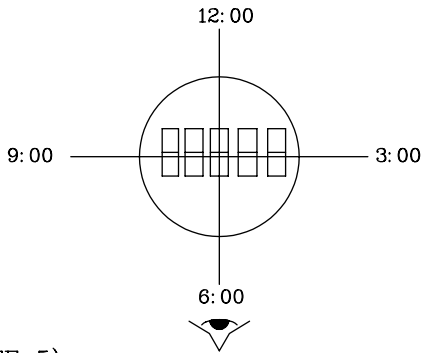

(NOTE 5)

Definition of Viewing Angle

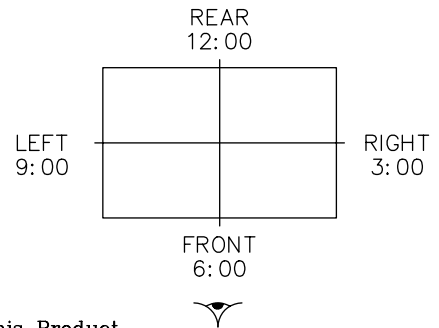
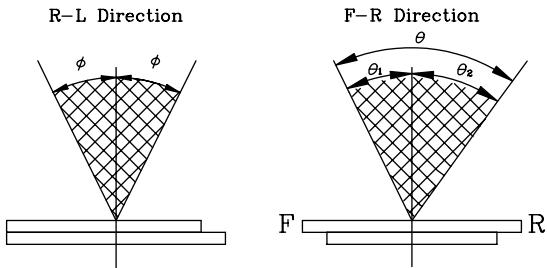

*For This Product
The Viewing Direction Is 6 O'clock
So $\theta_1 > \theta_2$

$$\theta = \theta_1 + \theta_2$$

*Conditions

- Operating Voltage : V_{op}
- Frame Frequency : 70Hz
- Applying Waveform : 1/N duty 1/a bias
- Contrast Ratio : larger than 2

(NOTE 6)

Definition of Contrast Ratio (Cr)

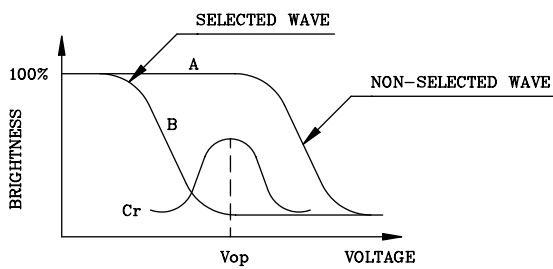

(positive type)

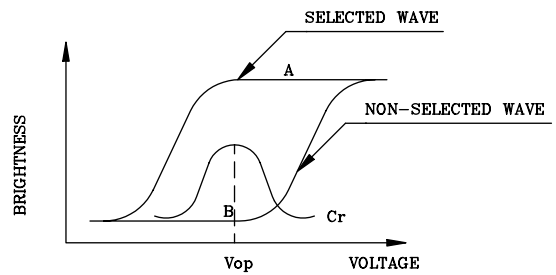

(negative type)

$$\text{Contrast Ratio : } Cr = A/B$$

*Conditions

- Viewing Angle : 0
- Frame Frequency : 70Hz
- Applying Waveform : 1/N duty 1/a bias

5. INTERNAL PIN CONNECTION

Pin NO.	Symbol	Function
1	RS	H:Data Input L:Instruction Input
2	R/ \bar{W}	H:Data Read L:Data Write
3	E	Enable
4	DB0	Data Bus
5	DB1	
6	DB2	
7	DB3	
8	DB4	
9	DB5	
10	DB6	
11	DB7	
12	Vss	0V Power Supply
13	Vdd	+5V Power Supply
14	VO	Operating Voltage for LCD Driving

6. POWER SUPPLY/BOOSTER CAPACITANCE

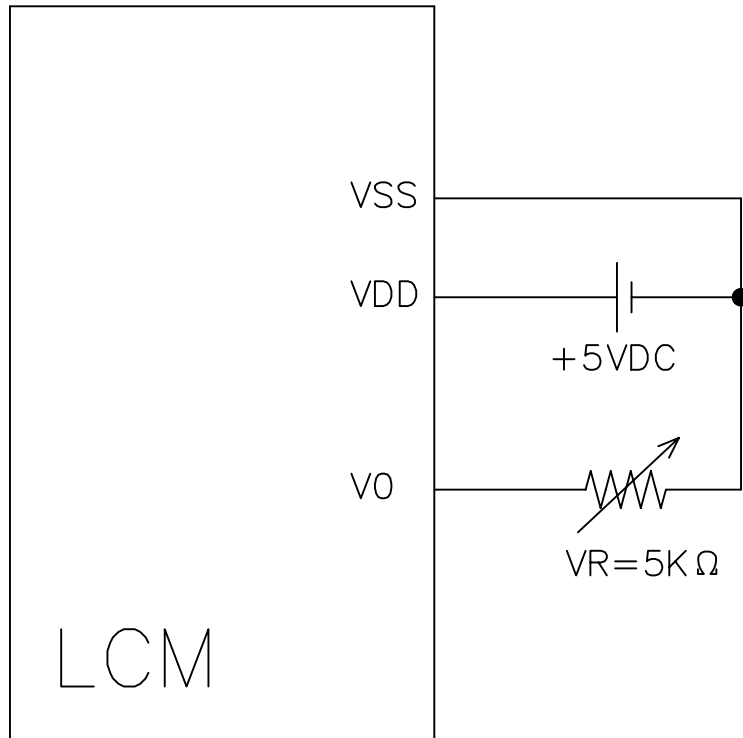

7. MPU INTERFACE/BLOCK DIAGRAM

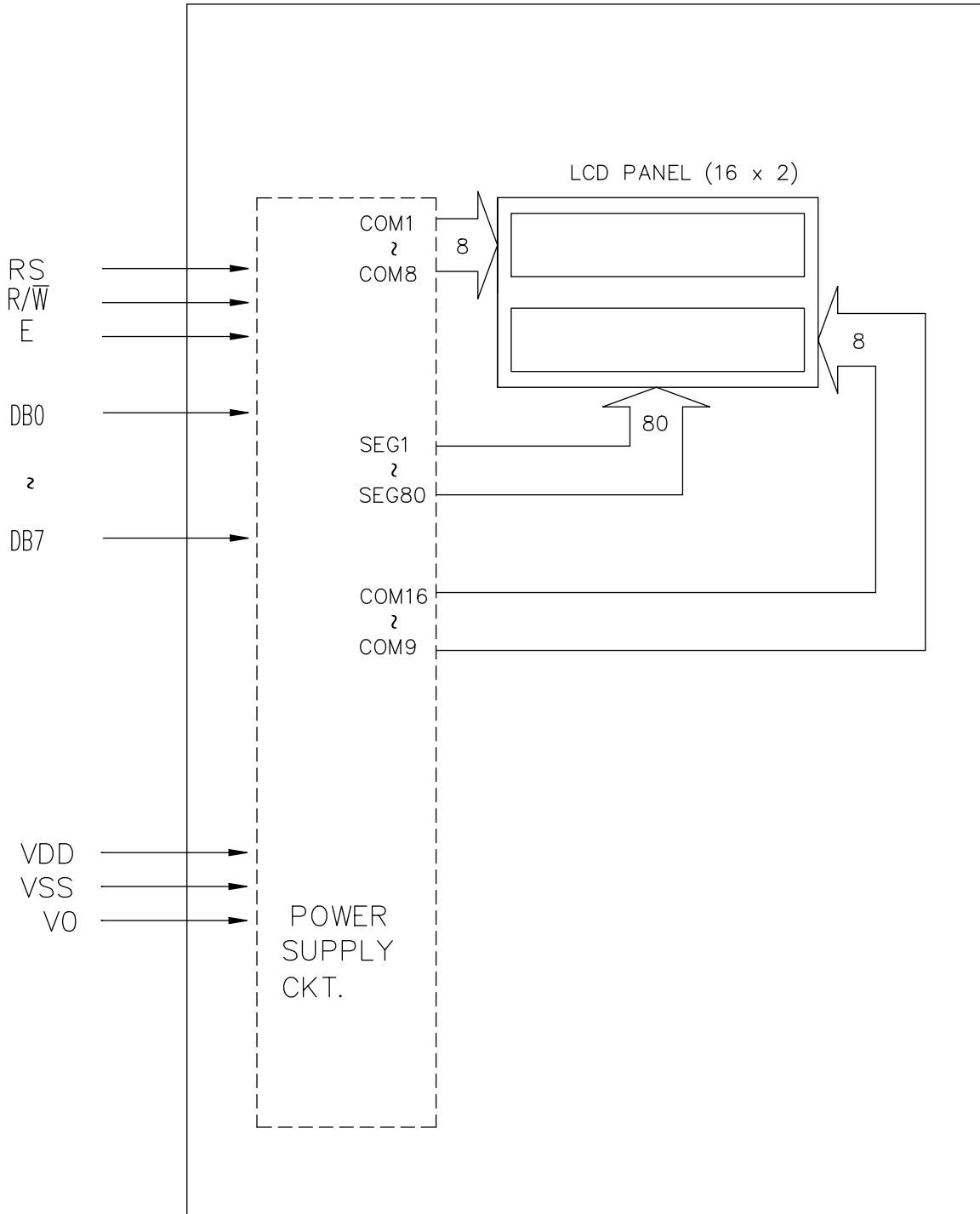

8.NT7605 Series Commands

Command	Command Code										Function
	RS	RW	DB7	DB6	DB5	DB4	DB3	DB2	DB1	DB0	
(1)Display Clear	0	0	0	0	0	0	0	0	0	1	Clear entire display area, Restore display from shift, and load address counter with DD RAM address 00H.
(2)Display/Cursor Home	0	0	0	0	0	0	0	0	1	*	Restore display from shift and load address counter with DD RAM address 00H.
(3)Entry Mode Set	0	0	0	0	0	0	0	1	I/D	S	Specify direction of cursor movement and display shift mode. This operation takes place after each data transfer (read/write).
(4)Display ON/OFF	0	0	0	0	0	0	1	D	C	B	Specify activation of display (D) cursor (C) and blinking of character at cursor position (B).
(5)Display/Cursor Shift	0	0	0	0	0	1	S/C	R/L	*	*	Shift display or move cursor.
(6)Function Set	0	0	0	0	1	DL	N	F	*	*	Set interface data length (DL) number of display line (N),and character font (F).
(7)RAM Address Set	0	0	0	1	(ACG)				Load the address counter with a CG RAM address. Subsequent data access is for CG RAM data.
(8)DD RAM Address Set	0	0	1	(ADD)					Load the address counter with a DD RAM address. Subsequent data access is for DD RAM data.
(9)Busy Flag/Address Counter Read	0	1	BF	(AC)					Read Busy Flag (BF) and contents of Address Counter (AC).
(10)CG RAM/DD RAM Data Write	1	0	(Write data)						Write data to CG RAM or DD RAM.
(11)CG RAM/DD RAM Data Read	1	1	(Read data)						Read data to CG RAM or DD RAM.
<p>I/D=1: Increment S=1: Display Shift ON D=1: Display ON C=1: Cursor Display ON B=1: Cursor Blink ON S/C=1: Shift Display R/L=1: Shift Right DL=1: 8-Bit N=1: Dual Line F=1: 5X10 Dots BF=1: Internal Operation</p> <p>I/D=0: Decrement S/C=0: Move Cursor R/L=0: Shift Left DL=0: 4-Bit N=0: Single Line F=0: 5X8 Dots BF=0: Ready for Instruction</p>											<p>DD RAM :Display Data RAM CG RAM :Character Generator RAM ACG :Character Generator RAM Address ADD :Display Data RAM Address AC : Address Counter</p>

Note 1: Symbol "*" signifies an insignificant bit

9. TIMING CHARACTERISTICS

(Read Operation)

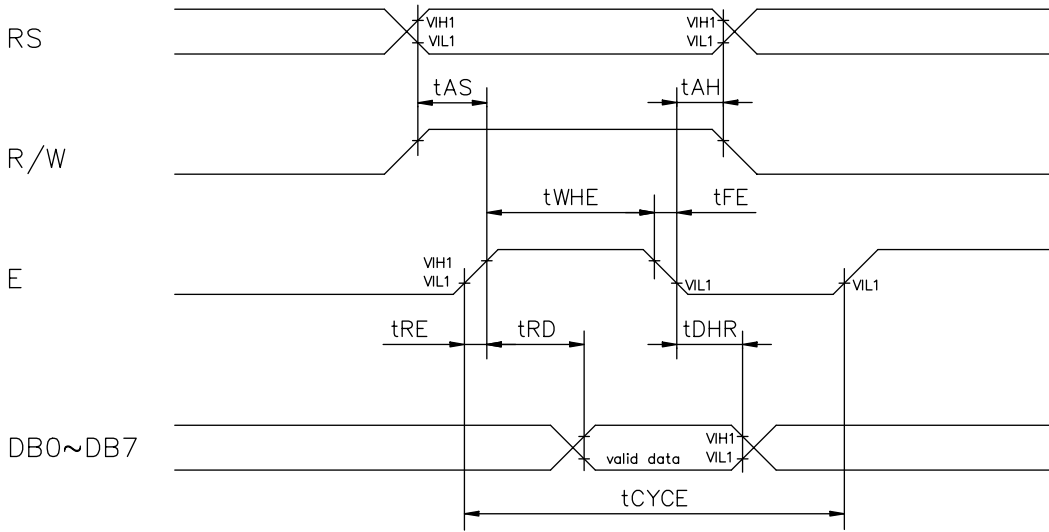

Figure 1. Bus Read Operation Sequence

(Write Operation)

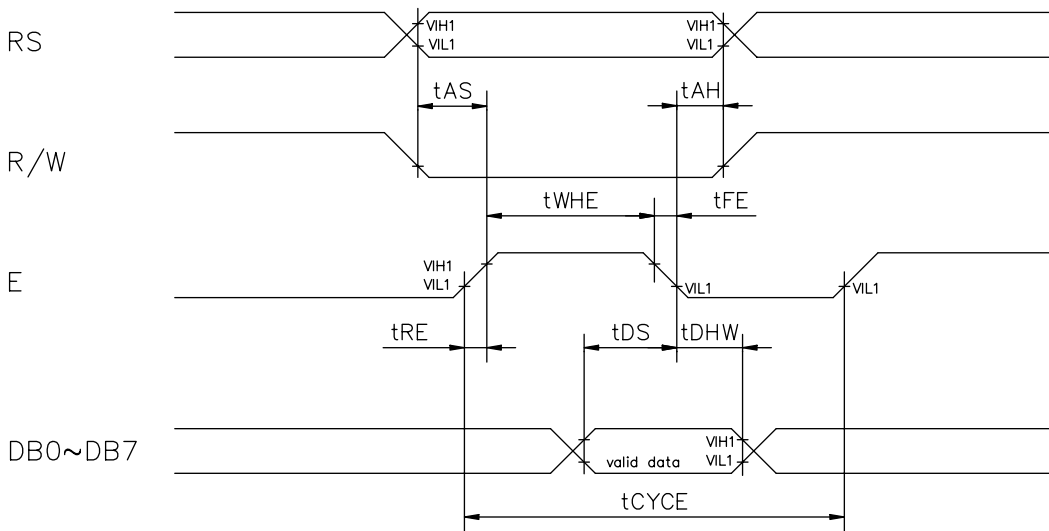
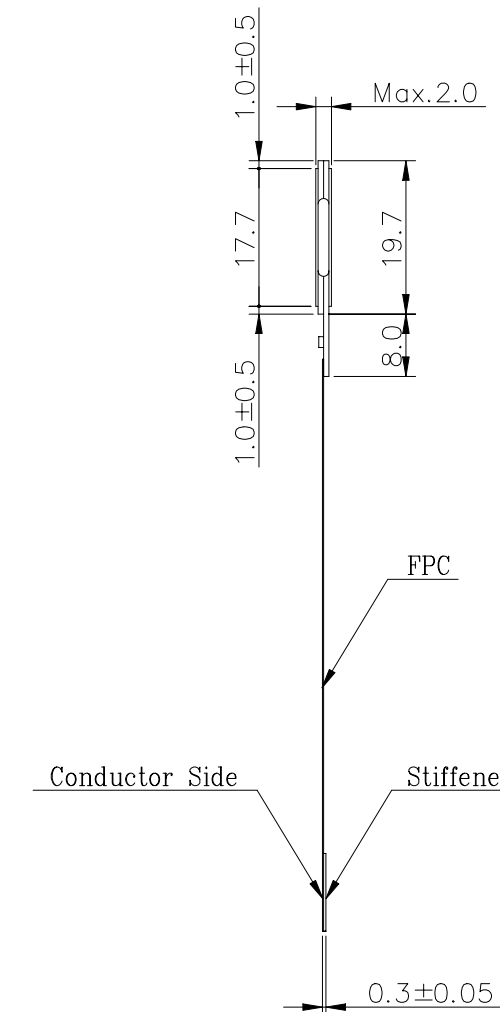
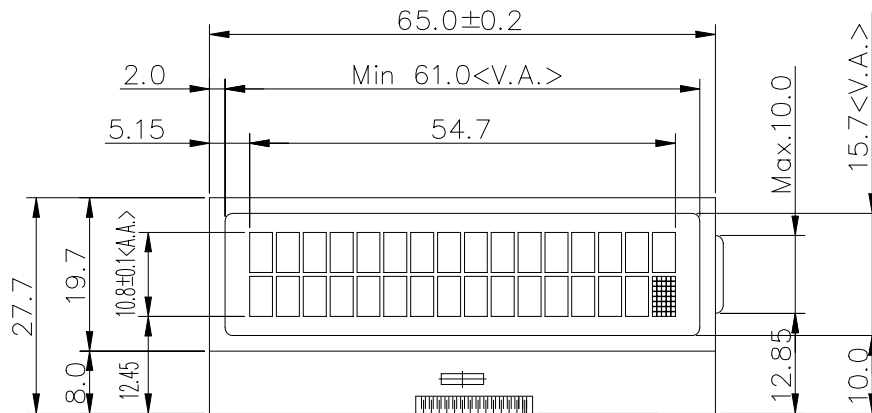
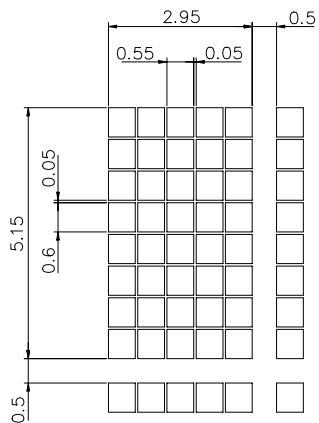
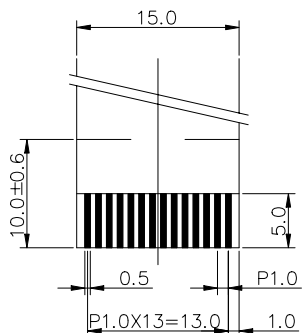

Figure 2. Bus Write Operation Sequence



Detail "A"
(Scale 15:1)



Detail "A"
(Scale 2:1)

Notes:

- 1.Resolution : 16X2 Characters
- 2.COG IC : NT7605
- 3.Glass Thickness : 0.7mm

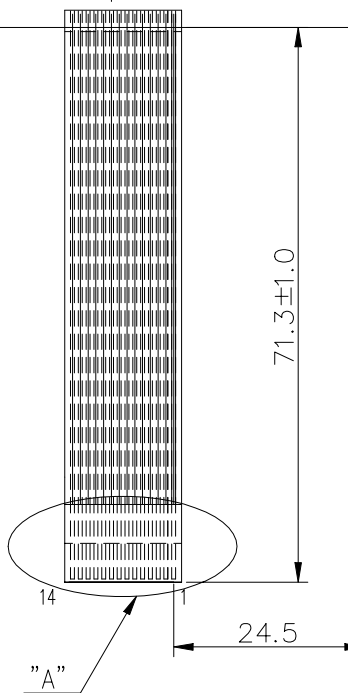

GENERAL TOLERANCE LIST

DIMENSION	TOLERANCE
$L \leq 6$	± 0.25 (mm)
$6 < L \leq 18$	± 0.3 (mm)
$18 < L \leq 50$	± 0.4 (mm)
$50 < L \leq 125$	± 0.5 (mm)
$125 < L$	± 0.6 (mm)
ANGLE	$\pm 1^{\circ}$ (DEG)

AZ DISPLAYS, INC.

ACM1602Z

Pin NO.	Symbol	Function
1	RS	H:Data Input L:Instruction Data Input
2	R/W	H:Data Read L:Data Write
3	E	Enable
4	DB0	Data Bus
5	DB1	
6	DB2	
7	DB3	
8	DB4	
9	DB5	
10	DB6	
11	DB7	
12	Vss	0V Power Supply
13	Vdd	+5V Power Supply
14	VO	Operating Voltage for LCD Driving

REV. NO.	DESCRIPTION	DATE	DESIGN	CHECK	APPROVE	DWG NO.	SCALE	UNIT		
5						M409-D0A	1/1	mm		
4					CHECK					
3					DESIGN				J.S HUANG	89.08.29
2					DRAWN				J.S HUANG	89.08.29
1					NAME					DATE
						APPROVE		THIRD ANGLE P.		