

PRELIMINARY
 Notice: This is not a final specification.
 Some parametric limits are subject to change.

MITSUBISHI SOFT RECOVERY DIODE
FD1500AU-120DA

HIGH POWER, HIGH FREQUENCY
 PRESS PACK TYPE

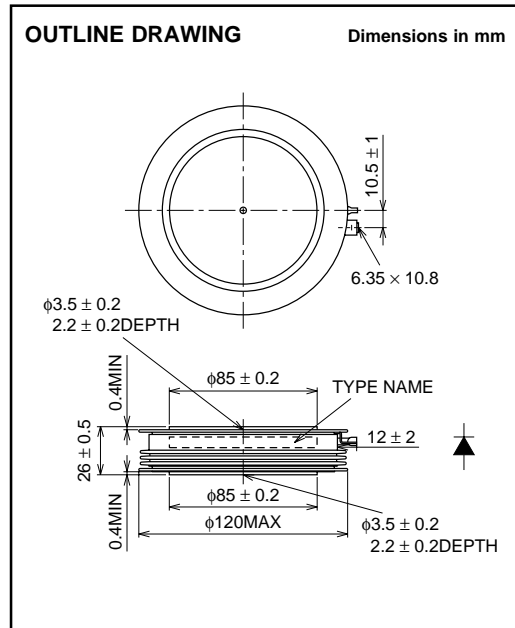
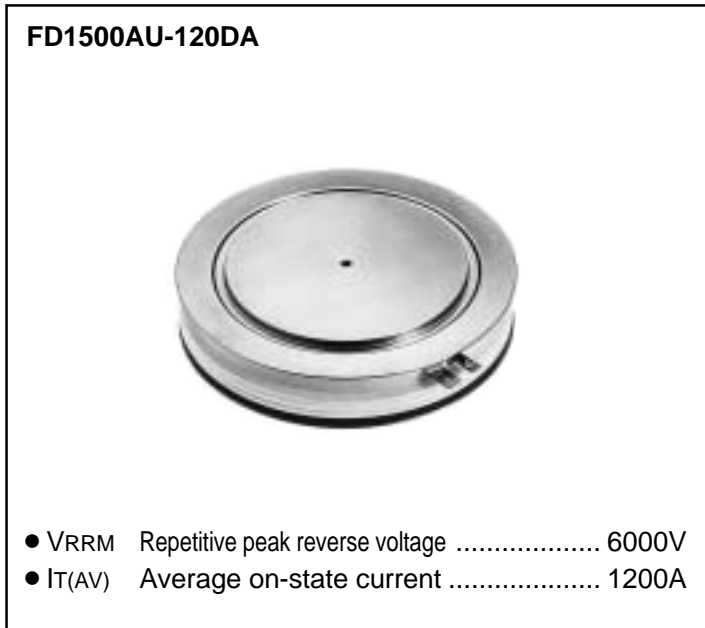

APPLICATION

- High-power inverters
- Fly-hwheel diode for GCT Thyristor
- Power supplies as high frequency rectifiers

MAXIMUM RATINGS

Symbol	Parameter	Conditions	Voltage class	Unit
VRRM	Repetitive peak reverse voltage	—	6000	V
VRSM	Non-repetitive peak reverse voltage	—	6000	V
VR(DC)	DC reverse voltage	—	4800	V
V(LTDS)	Long term DC stability voltage	$\lambda = 100\text{Fit}$	3200	V

Symbol	Parameter	Conditions	Ratings	Unit
IF(RMS)	RMS forward current	Applied for all condition angles	1900	A
IF(AV)	Average forward current	$f = 60\text{Hz}$, sinewave $\theta = 180^\circ$, $T_r = 74^\circ\text{C}$	1200	A
IFSM	Surge forward current	One half cycle at 60Hz, $T_j = 125^\circ\text{C}$ start	26	kA
I^2t	Current-squared, time integration		2.8×10^6	A^2s
di/dt	Critical rate of rise of reverse recovery current	$I_{FM} = 1500\text{A}$, $V_R = 3000\text{V}$, $T_j = 25/125^\circ\text{C}$ $C_C = 6\mu\text{F}$, $L_C = 0.3\mu\text{H}$ (See Fig. 1, 2)	1000	$\text{A}/\mu\text{s}$
T_j	Operation junction temperature		-40 ~ 125	$^\circ\text{C}$
T_{stg}	Storage temperature		-40 ~ 150	$^\circ\text{C}$
—	Mounting force required	(Recommended value 47kN)	39 ~ 55	kN
—	Weight	Typical value 1450g	—	g

ELECTRICAL CHARACTERISTICS

Symbol	Parameter	Test conditions	Limits			Unit
			Min.	Typ.	Max.	
VFM	Forward voltage	$I_{FM} = 3400\text{A}$, $T_j = 125^\circ\text{C}$	—	—	5	V
IRRM	Repetitive peak reverse current	$V_{RM} = 6000\text{V}$, $T_j = 125^\circ\text{C}$	—	—	150	mA
QRR	Reverse recovery charge	$I_{FM} = 1500\text{A}$, $di/dt = 1000\text{A}/\mu\text{s}$, $V_R = 3000\text{V}$, $T_j = 125^\circ\text{C}$	—	—	5400	μC
Erec	Reverse recovery energy	$C_C = 6\mu\text{F}$, $L_C = 0.3\mu\text{H}$ (See Fig. 1, 2)	—	—	9.4	J/P
$R_{th(j-f)}$	Thermal resistance	Junction to Fin	—	—	0.0071	K/W

PRELIMINARY
 Notice: This is not a final specification.
 Some parametric limits are subject to change.

FD1500AU-120DA

**HIGH POWER, HIGH FREQUENCY
 PRESS PACK TYPE**

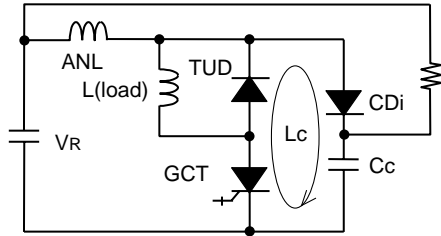

Fig. 1 Reverse recovery test circuit

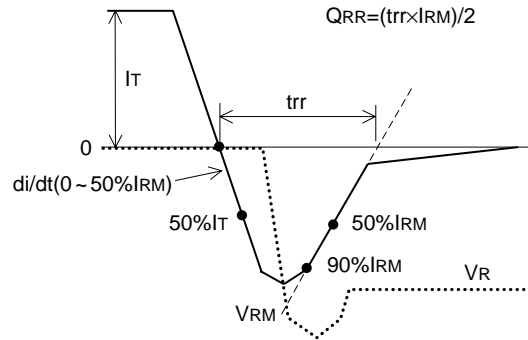

Fig. 2 Reverse recovery waveform

PERFORMANCE CURVES

