

液晶之友 电话: 020-33819057
 Http://www.lcdfriends.com

PRODUCT SPECIFICATION

MONOCHROME LCD MODULE

PART NUMBER : FDA4004A

DESCRIPTION : 4x40 character

REVISION : Rev A

	Approval for Specification only		Approval for Sample Only
	Approval for Pre-production	x	Approval for Mass Production



FDA4004A (40 CHARACTERS x 4 LINES)

FEATURES

- ◆ 5 x 7 DOTS WITH CURSOR
- ◆ BUILT-IN CONTROLLER (KS0066 OR EQUIVALENT)
- ◆ 5 V POWER SUPPLY
- ◆ 1/16 DUTY CYCLE
- ◆ 4.2 V LED FORWARD VOLTAGE

MECHANICAL DATA

ITEM	DIMENSIONS	UNIT
Module Size (W x H x T)	190.0 x 54.0 x 8.8 (13.0 LED)	mm
Viewing Area (W x H)	149.0 x 29.5	mm
Character Size (W x H)	2.78 x 4.89	mm
Character Pitch (W x H)	3.53 x 6.09	mm
Dot Size (W x H)	0.50 x 0.55	mm
Dot Pitch (W x H)	0.57 x 0.62	mm

INTERFACE PIN CONNECTIONS

NO.	SYMBOL	FUNCTION	NO.	SYMBOL	FUNCTION
1	DB7	Data Bit 7	9	E1	Enable IC1
2	DB6	Data Bit 6	10	R/W	Read/Write
3	DB5	Data Bit 5	11	RS	Register Select
4	DB4	Data Bit 4	12	Vo	Contrast Adj.
5	DB3	Data Bit 3	13	Vss	Supply Ground
6	DB2	Data Bit 2	14	VDD	Supply Voltage
7	DB1	Data Bit 1	15	E2	Enable IC2
8	DB0	Data Bit 0	16	NC	No Control

ELECTRICAL CHARACTERISTICS

ITEM	SYMBOL	CONDITION	MIN.	TYP.	MAX.	UNIT
LCD Operating Voltage	V _{DD-Vo}	T=0°C	-	4.8	-	V
		T=25°C	-	4.5	-	V
		T=50°C	-	4.2	-	V
Supply Voltage	V _{DD-VSS}	-	4.7	5	5.3	V
Supply Current	I _{DD}	-	-	5.2	10.8	mA
Input Voltage	"HIGH" Level	V _{IH}	-	2.2	-	V _{DD} V
	"LOW" Level	V _{IL}	-	0	-	0.6 V
Output Voltage	"HIGH" Level	V _{OH}	-	2.4	-	V
	"LOW" Level	V _{OL}	-	-	-	0.4 V

BLOCK DIAGRAM

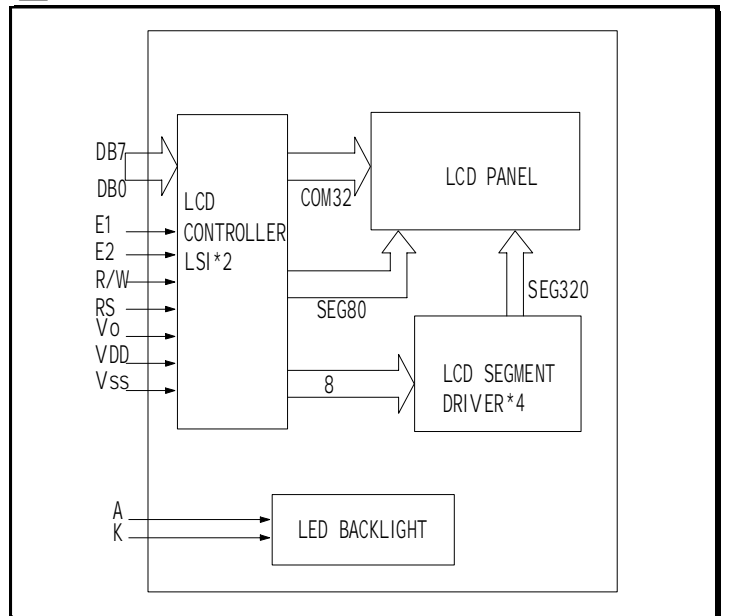

EXTERNAL DIMENSIONS

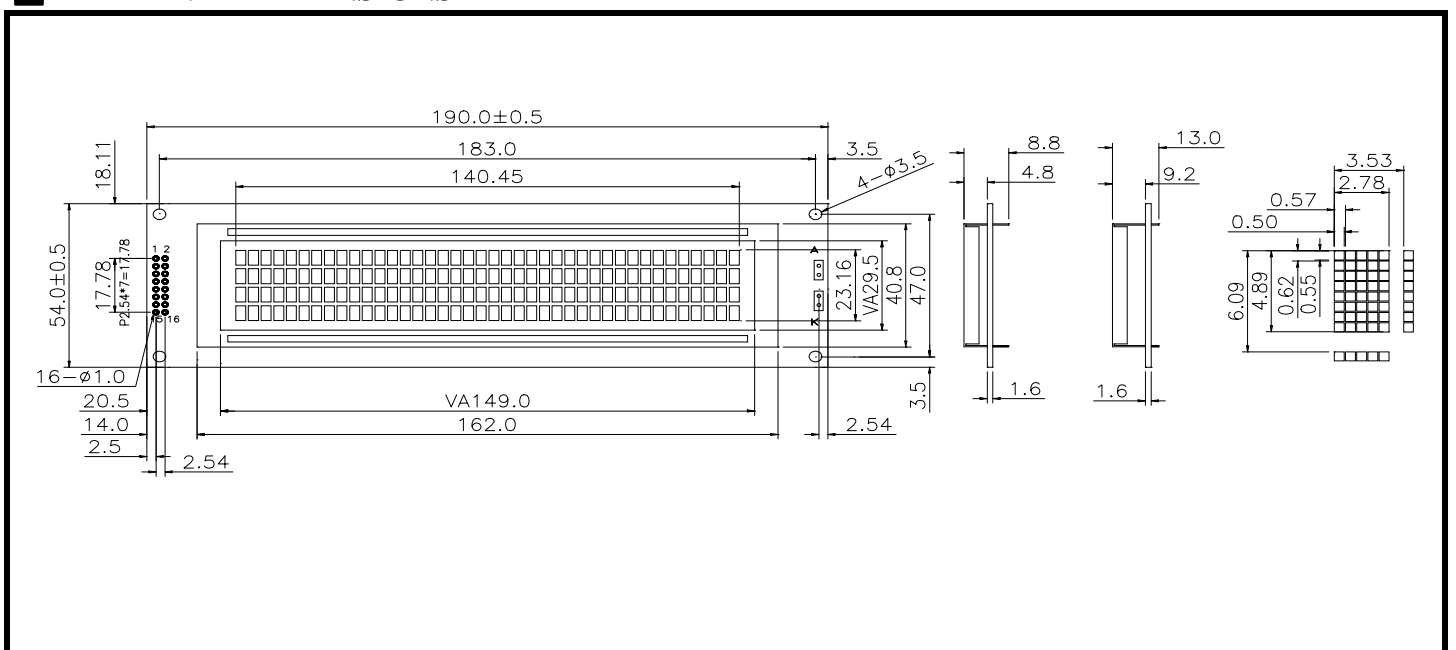

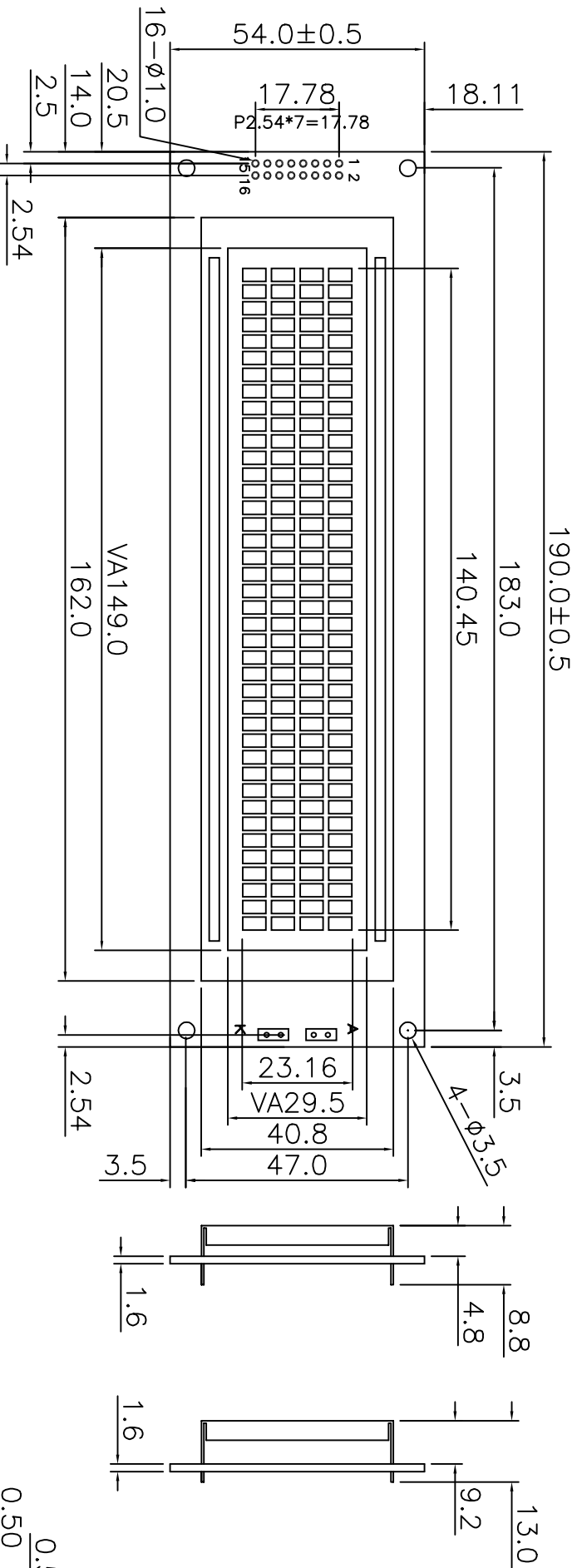

PIN NO	SIGNAL
1	DB7
2	DB6
3	DB5
4	DB4
5	DB3
6	DB2
7	DB1
8	DB0
9	E1
10	R/W
11	RS
12	VO
13	VSS
14	VDD
15	E2
16	NC

SCALE 4:1

NOTE	ITEM	CONTENT	DATA	REV	TOLERANCE	SCALE	UNIT	DWYN	DATE	TITLE	MODEL	DWG NO	PAGE
		CHANGE NUMBER	2004.03.01	0	X. ±0.30 X ±0.20 .XX±0.05	1/1	mm	G111	2004.03.01	MODULE	SC4004A	A-A1-0028	1/1
SUNLIKE DISPLAY													