

# FDB101S-FDB107S

Silicon Bridge Rectifiers

**VOLTAGE RANGE: 50 --- 1000 V**

**CURRENT: 1.0 A**



## Features

- ◇ Rating to 1000V PRV
- ◇ Surge overload rating to 30 Amperes peak
- ◇ Ideal for printed circuit board
- ◇ Reliable low cost construction utilizing molded plastic technique results in inexpensive product
- ◇ Lead solderable per MIL-STD-202 method 208
- ◇ Lead: silver plated copper, solderde plated
- ◇ Plastic material has UL flammability classification 94V-O
- ◇ Polarity symbols molded on body
- ◇ Weight: 0.016 ounces,0.45 grams

## DB-S

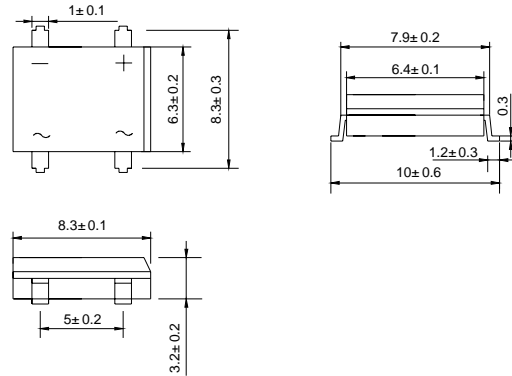

Dimensions in millimeters

## MAXIMUM RATINGS AND ELECTRICAL CHARACTERISTICS

Ratings at 25°C ambient temperature unless otherwise specified.

Single phase, half wave, 60 Hz, resistive or inductive load. For capacitive load, derate by 20%.

		FDB 101S	FDB 102S	FDB 103S	FDB 104S	FDB 105S	FDB 106S	FDB 107S	UNITS
Maximum recurrent peak reverse voltage	$V_{RRM}$	50	100	200	400	600	800	1000	V
Maximum RMS voltage	$V_{RMS}$	35	70	140	280	420	560	700	V
Maximum DC blocking voltage	$V_{DC}$	50	100	200	400	600	800	1000	V
Maximum average forward Output current @ $T_A=25^\circ C$	$I_{F(AV)}$	1.0							A
Peak forward surge current 8.3ms single half-sine-wave superimposed on rated load	$I_{FSM}$	30.0							A
Maximum instantaneous forward voltage at 1.0 A	$V_F$	1.3							V
Maximum reverse current @ $T_A=25^\circ C$ at rated DC blocking voltage @ $T_A=100^\circ C$	$I_R$	10.0 1.0							$\mu A$ mA
Maximum reverse recovery time (Note1)	$t_{rr}$	150			250	500			ns
Operating junction temperature range	$T_J$	- 55 ---- + 125							°C
Storage temperature range	$T_{STG}$	- 55 ---- + 150							°C

NOTE:1. Measured with  $I_F=0.5A, I_R=1A, I_{rr}=0.25A$ .

## Ratings AND Characteristic Curves

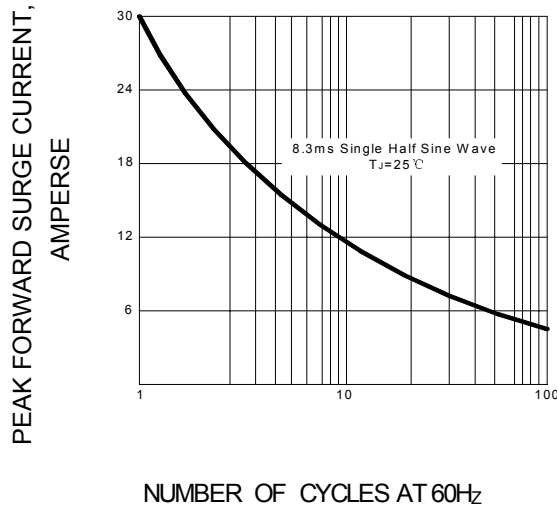
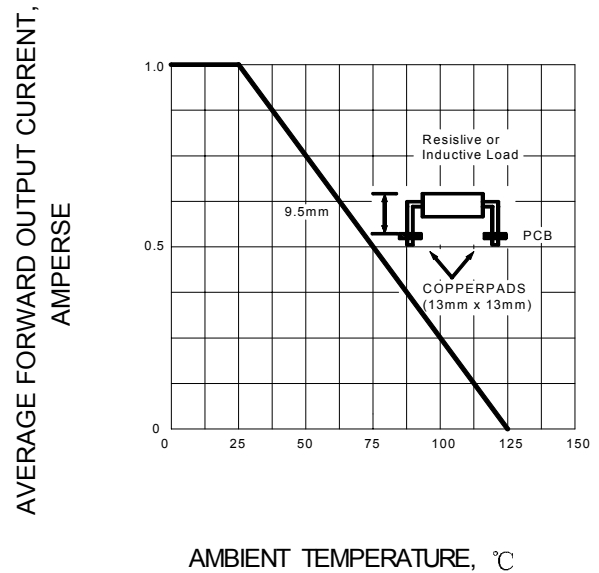
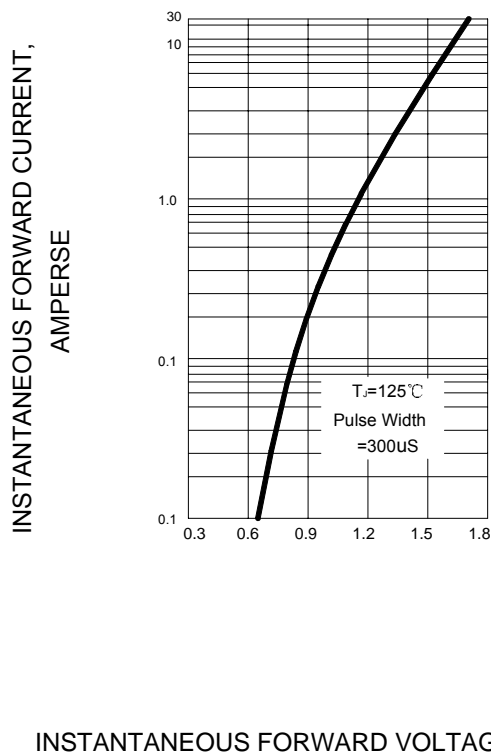
**FIG.1 – PEAK FORWARD SURGE CURRENT**

**FIG.2 – FORWARD DERATING CURVE**

**FIG.3 – TYPICAL FORWARD CHARACTERISTIC**

**FIG.4 – TYPICAL REVERSE CHARACTERISTIC**
