

N-Channel PowerTrench MOSFET

KDB3672 (FDB3672)

■ Features

- $r_{DS(ON)} = 24m\ \Omega$ (Typ.), $V_{GS} = 10V$, $I_D = 44A$
- $Q_{g(tot)} = 24nC$ (Typ.), $V_{GS} = 10V$
- Low Miller Charge
- Low QRR Body Diode
- UIS Capability (Single Pulse and Repetitive Pulse)

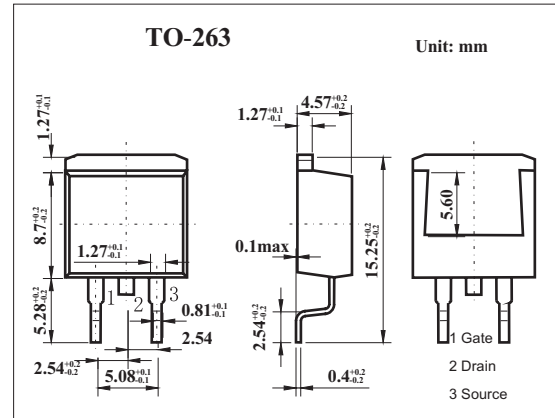
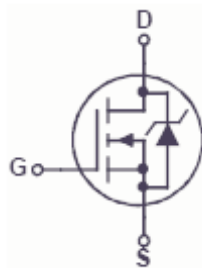

■ Absolute Maximum Ratings $T_a = 25^\circ C$

Parameter	Symbol	Rating	Unit	
Drain to source voltage	V_{DSS}	100	V	
Gate to source voltage	V_{GSS}	± 20	V	
Drain current-Continuous	I_D	$T_c = 25^\circ C$	44	A
		$T_A = 25^\circ C$	7.2	A
Power dissipation Derate above $25^\circ C$	P_D	120	W	
		0.8	W/ $^\circ C$	
Thermal Resistance Junction to Ambient	$R_{\theta JA}$	62	$^\circ C/W$	
Thermal Resistance, Junction-to-Case	$R_{\theta JC}$	1.25	$^\circ C/W$	
Channel temperature	T_{ch}	175	$^\circ C$	
Storage temperature	T_{stg}	-55 to +175	$^\circ C$	

KDB3672 (FDB3672)

■ Electrical Characteristics Ta = 25°C

Parameter	Symbol	Testconditions	Min	Typ	Max	Unit
Drain to source breakdown voltage	V _{DSS}	I _D =250μA, V _{GS} =0V	100			V
Drain cut-off current	I _{DSS}	V _{DS} =80V, V _{GS} =0			1	μA
		V _{DS} =80V, V _{GS} =0, T _C =150°C			250	μA
Gate leakage current	I _{GSS}	V _{GS} =±20V			±100	nA
Gate threshold voltage	V _{GS(th)}	V _{DS} = V _{GS} , I _D = 250μA	2.0		4.0	V
Drain to source on-state resistance	R _{DS(on)}	V _{GS} =10V, I _D =44A		0.024	0.028	Ω
		V _{GS} =6V, I _D =21A		0.031	0.047	
		V _{GS} =10V, I _D =44A, T _C =175°C		0.054	0.068	
Input capacitance	C _{iss}			1710		pF
Output capacitance	C _{oss}	V _{DS} =25V, V _{GS} =0, f=1MHZ		247		pF
Reverse transfer capacitance	C _{rss}			62		pF
Total Gate Charge at 10V	Q _{g(TOT)}	V _{GS} = 0V to 10V		24	31	nC
Threshold Gate Charge	Q _{g(TH)}	V _{GS} = 0V to 2V		3.5	4.5	nC
Gate to Source Gate Charge	Q _{gs}			11		nC
Gate Charge Threshold to Plateau	Q _{gs2}	V _{DS} = 50 V, I _D = 44A, I _g =1.0mA		7.2		nC
Gate to Drain "Miller" Charge	Q _{gd}			4.5		nC
Turn-On Time	t _{ON}				104	ns
Turn-On Delay Time	t _{d(ON)}			11		ns
Rise Time	t _r	V _{DD} = 50 V, I _D = 44A,		59		ns
Turn-Off Delay Time	t _{d(OFF)}	V _{GS} = 10 V, R _{GS} = 11.0 Ω		26		ns
Fall Time	t _f			44		ns
Turn-Off Time	t _{OFF}				104	ns
Source to Drain Diode Voltage	V _{SD}	I _{SD} =44A			1.25	V
		I _{SD} =21A			1.0	V
Reverse Recovery Time	t _{rr}	I _{SD} = 44A, dI _{SD} /dt = 100A/μs			52	ns
Reverse Recovered Charge	Q _{Rr}	I _{SD} = 44A, dI _{SD} /dt = 100A/μs			80	nC