

## Photodiodes



FDS010



### Description

The Thorlabs FDS010 photodiode is ideal for measuring both pulsed and CW fiber light sources, by converting the optical power to an electrical current. The detector is housed in a TO-5 package with an anode, cathode, and case connection. The photodiode anode produces a current, which is a function of the incident light power and the wavelength. The responsivity  $\mathfrak{R}(\lambda)$ , can be read from the responsivity graph to estimate the amount of photocurrent to expect. This can be converted to a voltage by placing a load resistor ( $R_L$ ) from the photodiode anode to the circuit ground. The output voltage is derived as:

$$V_o = P \times \mathfrak{R}(\lambda) \times R_L$$

The bandwidth,  $f_{BW}$ , and the rise time response,  $t_R$ , are determined from the diode capacitance,  $C_J$ , and the load resistance,  $R_L$ , as shown below. Placing a bias voltage from the photo diode cathode to the circuit ground can lower the photo diode capacitance.

$$f_{BW} = \frac{1}{2\pi(R_L)C_j}, t_R = \frac{0.35}{f_{BW}}$$

### Specifications

Specification	Value
Wavelength Range	200 - 1100 nm
Active Area	Ø1.02 mm (0.82 mm <sup>2</sup> )
Rise/Fall Time ( $R_L=50 \Omega$ , 20 V)	<1 ns
Bandwidth ( $R_L=50 \Omega$ , -3 dB, 5 V)	350 MHz Min
NEP (900 nm, 20 V)	$5.0 \times 10^{-14}$ W/Hz <sup>1/2</sup>
Dark Current, Max (20 V)	2.5 nA
Capacitance, Typical	10 pF @ 0 V 2 pF @ -10 V
Package	TO-5, 0.36" can

Specification	Value
Sensor Material	Si PIN
<b>Max Ratings</b>	
Damage Threshold, CW	n/a
Damage Threshold, 10 ns Pulse	n/a
Max Bias (Reverse) Voltage	25 V
Operating Temperature	-40 to 100 °C
Storage Temperature	-55 to 125 °C
Reverse Current	5 mA
Forward Current	5 mA

### Recommended Circuit Diagram

Application of a reverse bias can greatly improve the response speed and linearity of the device. This is due to increase in the depletion region width and, consequently, decrease in junction capacitance. However, the dark current and noise will increase.

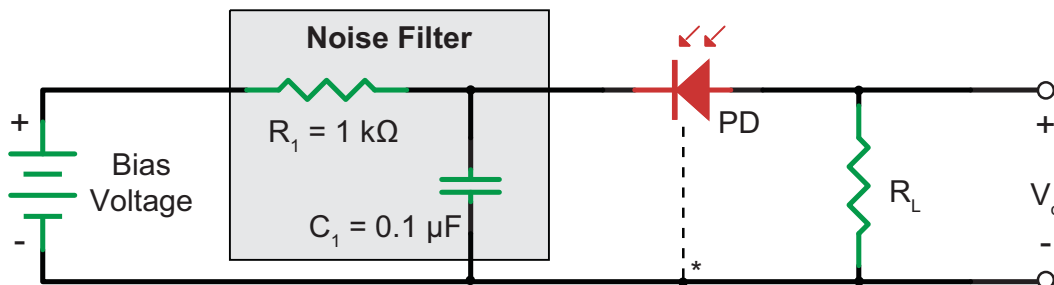

\* Case ground for PD with a third lead.

## Graphs

The responsivity of a photodiode is a measure of its sensitivity to light, and it is defined as the ratio of the photocurrent  $I_P$  to the incident light power  $P$  at a given wavelength:

$$R_\lambda = \frac{I_P}{P}$$

In other words, it is a measure of the effectiveness of the conversion of light power into electrical current. Responsivity varies from lot to lot and with the wavelength of the incident light, applied reverse bias, and temperature. It increases slightly with applied reverse bias due to improved charge collection efficiency in the photodiode. The change in temperature increases or decreases the width of the band gap and varies inversely with the temperature.

### FDS Series Photodiode Responsivity

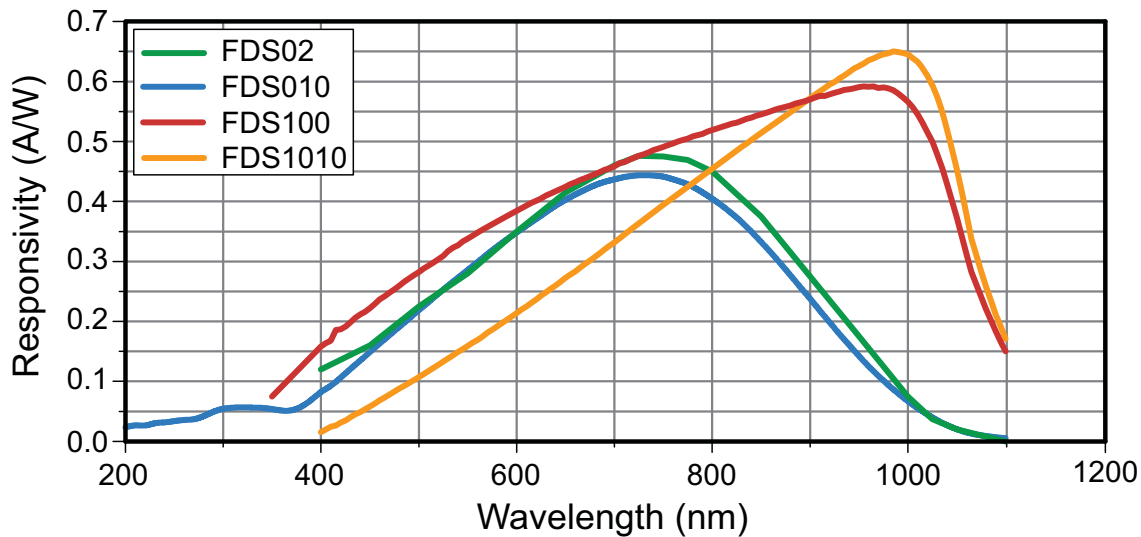

## Drawings

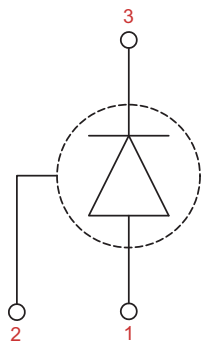

Pin	Description
1	Anode
2	Case
3	Cathode

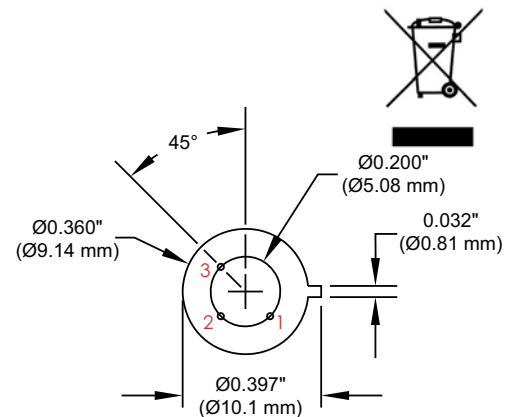
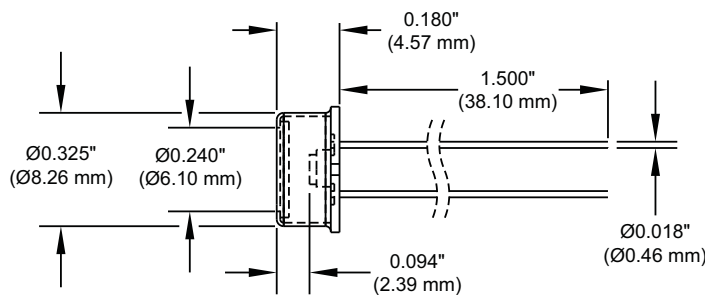

USA, Canada, & S. America  
 Thorlabs, Inc.  
 435 Route 206  
 Newton, NJ 07860, USA  
 Tel: 973-579-7227  
 Fax: 973-300-3600  
 www.thorlabs.com  
 email: feedback@thorlabs.com

Europe  
 Thorlabs GmbH  
 Hans-Böckler-Str. 6  
 85221 Dachau, Germany  
 Tel: +49-(0)8131-5956-0  
 Fax: +49-(0)8131-5956-99  
 www.thorlabs.com  
 email: Europe@thorlabs.com

UK and Ireland  
 Thorlabs LTD.  
 1 Saint Thomas Place, Ely  
 Cambridgeshire CB7 4EX, GB  
 Tel: +44 (0)1353-654440  
 Fax: +44 (0)1353-654444  
 www.thorlabs.com  
 email: sales.uk@thorlabs.com

Scandinavia  
 Thorlabs Sweden AB  
 Box 141 94  
 400 20 Göteborg, Sweden  
 Tel: +46-31-733-30-00  
 Fax: +46-31-703-40-45  
 www.thorlabs.com  
 email: scandinavia@thorlabs.com

Japan and Asia  
 Thorlabs Japan Inc.  
 5-17-1, Ohtsuka  
 Bunkyo-ku, Tokyo 112-0012, Japan  
 Tel: +81-3-5979-8889  
 Fax: +81-3-5979-7285  
 www.thorlabs.jp  
 email: sales@thorlabs.jp

