



DATA IMAGE CORPORATION

TFT Module Specification

ITEM NO.: FG030568DSSWBGT1

Table of Contents

1. COVER & CONTENTS	1
2. RECORD OF REVISION	2
3. GENERAL SPECIFICATIONS	3
4. ABSOLUTE MAXIMUM RATINGS	3
5. ELECTRICAL CHARACTERISTICS	3
6. BLOCK DIAGRAM	4
7. INTERNAL PIN CONNECTIONS	5
8. INTERFACE TIMING	6
9. OPTICAL CHARACTERISTIC	9
10 TOUCH PANEL CHARACTERISTICS	11
11. QUALITY ASSURANCE	12
12. LCM PRODUCT LABEL DEFIN.....	13
13. PRECAUTIONS IN USE LCM	15
14. OUTLINE DRAWING	16
15. PACKAGE INFORMATION	17

Customer Companies	R&D Dept.	Q.C. Dept.	Eng. Dept.	Prod. Dept.
	<i>Jack</i>	Joe	<i>Ging.</i>	<i>Ben</i>
Approved by	Version:	Issued Date:	Sheet Code:	Total Pages:
	B	06/SEP/11'		17

3. GENERAL SPECIFICATIONS

Parameter	Specifications	Unit
Screen Size	3.45 (diagonal)	inch
Display Format	320 X RGB X 240	dots
Active Area	70.08 (W) x 52.56 (H)	mm
Dot Pitch	0.073(W) x 0.219 (H)	mm
Outline Dimension	77.8 (W) x 64.5 (H) x 4.0 (T)	mm
Pixel Configuration	Stripe	
Display Type	Active Matrix	
Number of Colors	262K Colors (R,G,B 6 Bit Digital each)	
Backlight	LED x 6	
Surface Treatment	Anti-Glare	
Weight	40	g
Power Supply Voltage	3.3V only (Including timing controller ,LCD power unit)	
View Angle Direction	6 o'clock (the direction it's hard to be discolored)	
Temperature Range	Operation	-20~+60 °C
	Storage	-30~+70 °C

4. ELECTRICAL ABSOLUTE MAXIMUM RATINGS

(GND=0V)

Parameter	Symbol	MIN.	MAX.	Unit	Remark
Power supply for Logic	VCC	-0.3	4.0	V	
Input voltage	VI	-0.3	4.0	V	Note 1
Input Current	Ii	0	1	A	

Note 1: R0~R7,G0~G7,B0~B7,CK,HSYNC,VSYNC.

5. ELECTRICAL CHARACTERISTICS

5.1 ELECTRICAL CHARACTERISTICS of LCD

(GND=0V, Ta=25 °C)

Parameter	Symbol	Condition	MIN.	TYP	MAX.	Unit
Power supply voltage	VCC	-	3.0	3.3	3.6	V
Input voltage for logic(note 1)	VI	"H" level	0.8xVCC		VCC	V
		"L" level	GND	-	0.2xVCC	V
Power supply Current (note 2)	ICC	VCC-GND=3.3V	-	12	15	mA

Note 1: R0~R7,G0~G7,B0~B7,CK,HSYNC,VSYNC.

Note 2:fv=60Hz, Ta=25 °C, Pattern used as display pattern :All Black.

Note 3:Need to make sure of flickering and rippling of display when setting the frame frequency in your set.

5.2 ELECTRICAL CHARACTERISTICS of BACK LIGHT

Parameter	Symbol	Condition	MIN.	TYP	MAX.	Unit	
LED Input voltage	VF	IF=20mA	18	20.4	22.8	V	
LED Frequency Current	IF	-	-	20	-	mA	
LED Dice Life Time			-	40000	-	Hours	Note1,2

Note 1 : LED current depend on following conditions.

Note 2 : under room temperature (25°C, Humidity RH 30-60% , 20mA) and normal driving conditions.

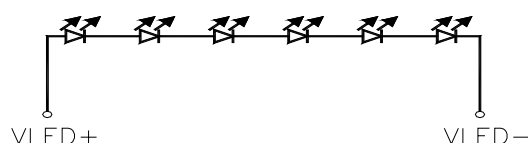

6. BLOCK DIAGRAM

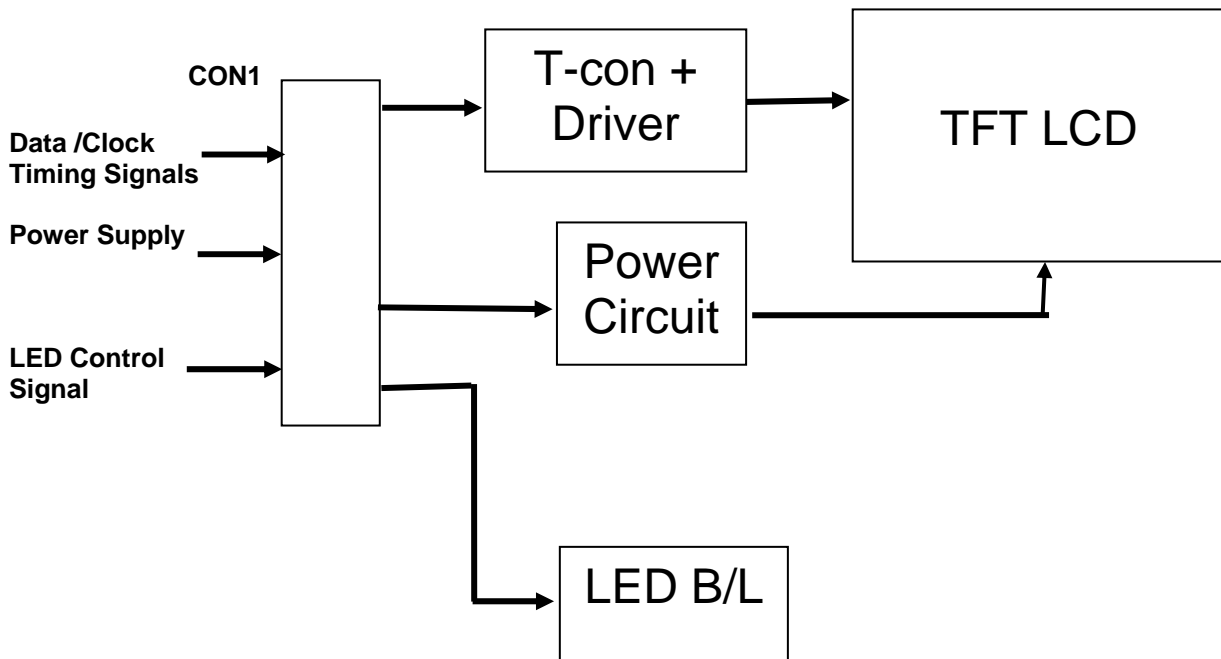

7. INTERNAL PIN CONNECTIONS

Pin No	Symbol	Function	Remark
1	GND	Ground	
2	GND	Ground	
3	Vcc	Power Supply : +3.3V	
4	Vcc	Power Supply : +3.3V	
5	R0	Red pixel data(LSB)	
6	R1	Red pixel data	
7	R2	Red pixel data	
8	R3	Red pixel data	
9	R4	Red pixel data	
10	R5	Red pixel data	
11	R6	Red pixel data	
12	R7	Red pixel data(MSB)	
13	G0	Green pixel data(LSB)	
14	G1	Green pixel data	
15	G2	Green pixel data	
16	G3	Green pixel data	
17	G4	Green pixel data	
18	G5	Green pixel data	
19	G6	Green pixel data	
20	G7	Green pixel data(MSB)	
21	B0	Blue pixel data(LSB)	
22	B1	Blue pixel data	
23	B2	Blue pixel data	
24	B3	Blue pixel data	
25	B4	Blue pixel data	
26	B5	Blue pixel data	
27	B6	Blue pixel data	
28	B7	Blue pixel data(MSB)	
29	GND	Ground	
30	CK(DOTCLK)	DOTCLK signal to sample each data	
31	DISP	Display ON/OFF signal ON=H (Vcc), OFF=L (GND).	
32	HSYNC	Horizontal synchronous signal	
33	VSYNC	Vertical synchronous signal	
34	NC	No Connection	
35	NC	No Connection	
36	NC	No Connection	
37	ID	Short with pin 38.	
38	ID	Short with pin 37.	
39	VLED+	Power supply of LED backlight	
40	VLED-	Ground of LED backlight	

8. INTERFACE TIMING

8.1 AC Characteristics

(Unless otherwise specified, Voltage Referenced to GND, $V_{CC} = 3.3V$, $T_a = 25^\circ C$)

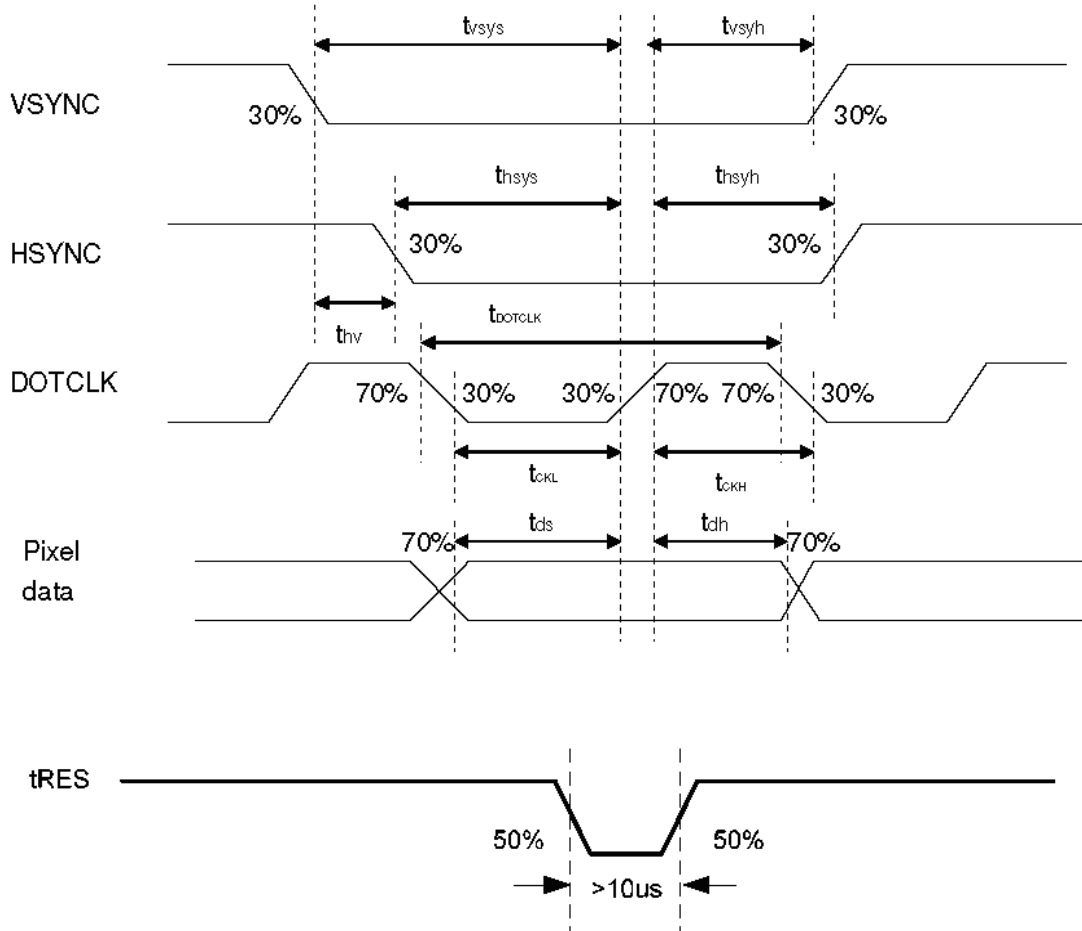
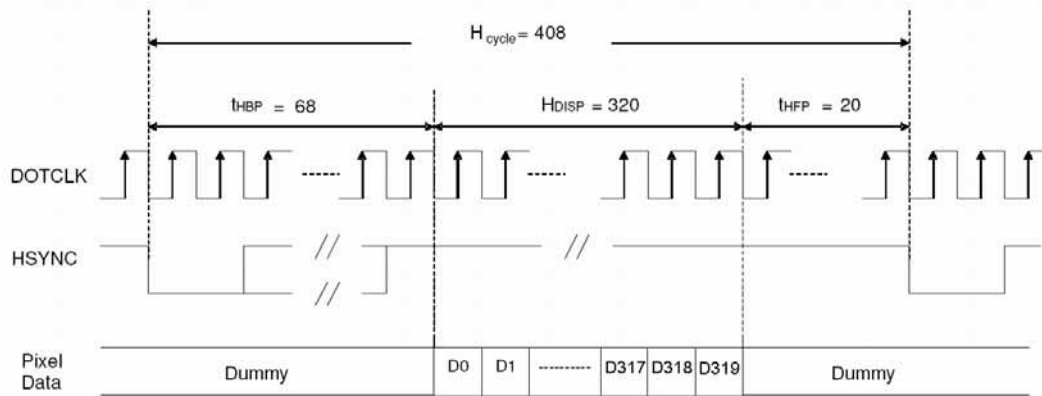

Figure 8.1-1 Pixel & tRES timing

Characteristics	Symbol	Min	Typ	Max	Unit
DOTCLK Frequency	fDOTCLK	-	6.5	10	MHz
DOTCLK Period	tDOTCLK	100	154	-	ns
Vertical Sync Setup Time	tvsys	20	-	-	ns
Vertical Sync Hold Time	tvsyh	20	-	-	ns
Horizontal Sync Setup Time	thsys	20	-	-	ns
Horizontal Sync Hold Time	thsyh	20	-	-	ns
Phase difference of Sync Signal Falling Edge	thv	1	-	240	tDOTCLK
DOTCLK Low Period	tCKL	50	-	-	ns
DOTCLK High Period	tCKH	50	-	-	ns
Data Setup Time	tds	8	-	-	ns
Data hold Time	tdh	8	-	-	ns
Reset pulse width	tRES	10	-	-	us

Table 8.1-1 Pixel & tRES timing



a) Horizontal Data Transaction Timing

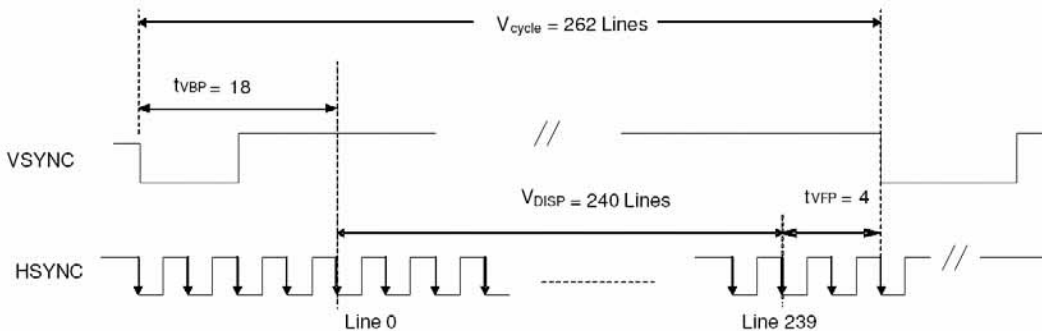

b) Vertical Data Transaction Timing

Figure 8.1-2 Data transaction timing in parallel RGB interface (SYNC mode)

Characteristics	Symbol	Min	Typ	Max	Unit	
DOTCLK Frequency	fDOTCLK	-	19.5	30	MHz	
DOTCLK Period	tDOTCLK	33.3	51.3	-	ns	
Horizontal Frequency (Line)	fH	-	15.72	22.35	KHz	
Vertical Frequency (Refresh)	fV	-	60	90	Hz	
Horizontal Back Porch	tHBP	-	204	-	tDOTCLK	
Horizontal Front Porch	tHFP	-	60	-	tDOTCLK	
Horizontal Data Start Point	tHBP	-	204	-	tDOTCLK	
Horizontal Blanking Period	tHBP + tHFP	-	264	-	tDOTCLK	
Horizontal Display Area	HDISP	-	960	-	tDOTCLK	
Horizontal Cycle	Hcycle	-	1224	1350	tDOTCLK	
Vertical Back Porch	tVBP	-	18	-	Lines	
Vertical Front Porch	tVFP	-	4	-	Lines	
Vertical Data Start Point	tVBP	-	18	-	Lines	
Vertical Blanking Period	tVBP + tVFP	-	22	-	Lines	
VS Pulse width	tWV		4			
Vertical Display Area	NTSC	VDISP		240	-	Lines
	PAL		280(PALM=0)			
			288(PALM=1)			
Vertical Cycle	NTSC	Vcycle		262	350	Lines
	PAL		313			

Table 8.1-2 Data transaction timing in normal operating mode

8.2 Power Off/On Sequence Timing

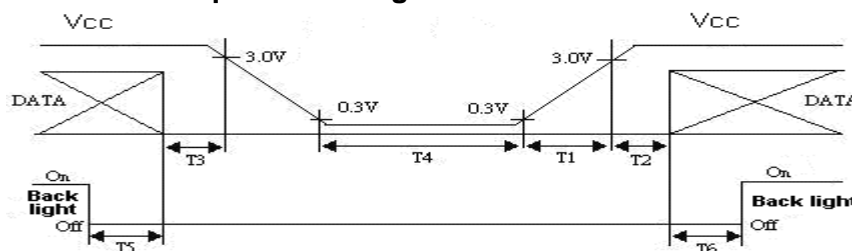

Timing Specifications:

 $0 < T1 \leq 15\text{ms}$
 $T2 > 0.5\text{S}$
 $0 < T3 \leq 0.1\text{S}$
 $T4 > 1\text{S}$
 $T5 > 0.1\text{S}$
 $T6 > 0.1\text{S}$

8.3 Color Data Input Assignment

Colors & Gray Scale	Gray Scale	Data signal																																	
		R0	R1	R2	R3	R4	R5	R6	R7	G0	G1	G2	G3	G4	G5	G6	G7	B0	B1	B2	B3	B4	B5	B6	B7										
		LSB							MSB							LSB							MSB												
Basic Color	Black	—	0	0	0	0	0	0	0	0	0	0	0	0	0	0	0	0	0	0	0	0	0	0	0	0	0	0	0	0	0	0	0	0	0
	Blue	—	0	0	0	0	0	0	0	0	0	0	0	0	0	0	0	0	0	0	1	1	1	1	1	1	1	1	1	1	1	1	1	1	1
	Green	—	0	0	0	0	0	0	0	0	0	0	0	0	0	0	0	0	0	1	1	1	1	1	1	1	1	1	1	1	1	1	1	1	1
	Cyan	—	0	0	0	0	0	0	0	0	0	0	0	0	0	0	0	0	0	1	1	1	1	1	1	1	1	1	1	1	1	1	1	1	1
	Red	—	1	1	1	1	1	1	1	1	1	1	1	1	1	1	1	1	1	0	0	0	0	0	0	0	0	0	0	0	0	0	0	0	0
	Magenta	—	1	1	1	1	1	1	1	1	1	1	1	1	1	1	1	1	1	0	0	0	0	0	0	0	0	0	0	0	0	0	0	0	0
	Yellow	—	1	1	1	1	1	1	1	1	1	1	1	1	1	1	1	1	1	1	1	1	1	1	1	1	1	1	1	1	1	1	1	1	1
	White	—	1	1	1	1	1	1	1	1	1	1	1	1	1	1	1	1	1	1	1	1	1	1	1	1	1	1	1	1	1	1	1	1	1
Gray Scale of Red	Black	GS0	0	0	0	0	0	0	0	0	0	0	0	0	0	0	0	0	0	0	0	0	0	0	0	0	0	0	0	0	0	0	0	0	
	↑	GS1	1	0	0	0	0	0	0	0	0	0	0	0	0	0	0	0	0	0	0	0	0	0	0	0	0	0	0	0	0	0	0	0	
	Darker	GS2	0	1	0	0	0	0	0	0	0	0	0	0	0	0	0	0	0	0	0	0	0	0	0	0	0	0	0	0	0	0	0	0	
		↑	↓																																
	↓	↓																																	
	Brighter	GS253	1	0	1	1	1	1	1	1	1	1	1	1	1	1	1	1	1	0	0	0	0	0	0	0	0	0	0	0	0	0	0	0	0
		↓	GS254	0	1	1	1	1	1	1	1	1	1	1	1	1	1	1	1	0	0	0	0	0	0	0	0	0	0	0	0	0	0	0	0
	Red	GS255	1	1	1	1	1	1	1	1	1	1	1	1	1	1	1	1	1	0	0	0	0	0	0	0	0	0	0	0	0	0	0	0	0
Gray Scale of Green	Black	GS0	0	0	0	0	0	0	0	0	0	0	0	0	0	0	0	0	0	0	0	0	0	0	0	0	0	0	0	0	0	0	0	0	
	↑	GS1	0	0	0	0	0	0	0	0	0	0	0	0	0	0	0	0	0	1	0	0	0	0	0	0	0	0	0	0	0	0	0	0	0
	Darker	GS2	0	0	0	0	0	0	0	0	0	0	0	0	0	0	0	0	0	0	0	0	0	0	0	0	0	0	0	0	0	0	0	0	0
		↑	↓																																
	↓	↓																																	
	Brighter	GS253	0	0	0	0	0	0	0	0	0	0	0	0	0	0	0	0	0	1	0	1	1	1	1	1	1	1	1	1	1	1	1	1	1
		↓	GS254	0	0	0	0	0	0	0	0	0	0	0	0	0	0	0	0	0	0	1	1	1	1	1	1	1	1	1	1	1	1	1	1
	Green	GS255	0	0	0	0	0	0	0	0	0	0	0	0	0	0	0	0	0	1	1	1	1	1	1	1	1	1	1	1	1	1	1	1	1
Gray Scale Blue	Black	GS0	0	0	0	0	0	0	0	0	0	0	0	0	0	0	0	0	0	0	0	0	0	0	0	0	0	0	0	0	0	0	0	0	
	↑	GS1	0	0	0	0	0	0	0	0	0	0	0	0	0	0	0	0	0	0	0	0	0	0	0	0	0	0	0	0	0	0	0	0	0
	Darker	GS2	0	0	0	0	0	0	0	0	0	0	0	0	0	0	0	0	0	0	0	0	0	0	0	0	0	0	0	0	0	0	0	0	0
		↑	↓																																
	↓	↓																																	
	Brighter	GS253	0	0	0	0	0	0	0	0	0	0	0	0	0	0	0	0	0	0	0	0	0	0	0	0	0	0	0	0	0	0	0	0	0
		↓	GS254	0	0	0	0	0	0	0	0	0	0	0	0	0	0	0	0	0	0	0	0	0	0	0	0	0	0	0	0	0	0	0	0
	Blue	GS255	0	0	0	0	0	0	0	0	0	0	0	0	0	0	0	0	0	0	0	0	0	0	0	0	0	0	0	0	0	0	0	0	0

0 : Low level voltage 1 : High level voltage

Each basic color can be displayed in 256 gray scales from 8 bit data signals. According to the combination of 24 bit data signals, the 16-million-color display can be achieved on the screen.

Correspondence between Data and Display Position

	S001	S002	S003	S004	S005	S006	S007	S008	-----	S959	S960
C001	R001	G001	B001	R002	G002	B002	R003	G003	-----	G320	B320
⋮											
C240	R001	G001	B001	R002	G002	B002	R003	G003	-----	G320	B320

9. OPTICAL CHARACTERISTIC

9.1. Specification:

 $T_a = 25^\circ\text{C}$

Parameter		Symbol	Condition	MIN.	TYP.	MAX.	Unit	Remarks
Viewing Angle	Horizontal	θ_{x+}	Center $CR \geq 10$	60	70	-	deg	Note 9-3
		θ_{x-}		60	70	-	deg	
	Vertical	θ_{y+}		40	50	-	deg	
		θ_{y-}		60	70	-	deg	
Contrast Ratio		CR		200	-	-		Note 9-1
Response time	Rise	T_r	Center	-	15	30	ms	Note 9-4
	Fall	T_f	$\theta_x = \theta_y = 0^\circ$	-	35	50	ms	
Uniformity		U		70	-	-	%	
Brightness			Center	160	200	-	cd/m^2	Note 9-2
Chromaticity	White	x	$\theta_x = \theta_y = 0^\circ$	0.25	0.30	0.35		
		y		0.28	0.33	0.38		

Note 9-1 : $CR = \frac{\text{Luminance when LCD is White}}{\text{Luminance when LCD is Black}}$ The test configurations of contrast ratio see section 9.2 .

Note 9-2 : 1. Topcon BM-7A luminance meter 1.0° field of view is used in the testing (after 2 minutes operation).
2. LED current = 20mA.

Note 9-3 : The definitions of viewing angles diagrams:

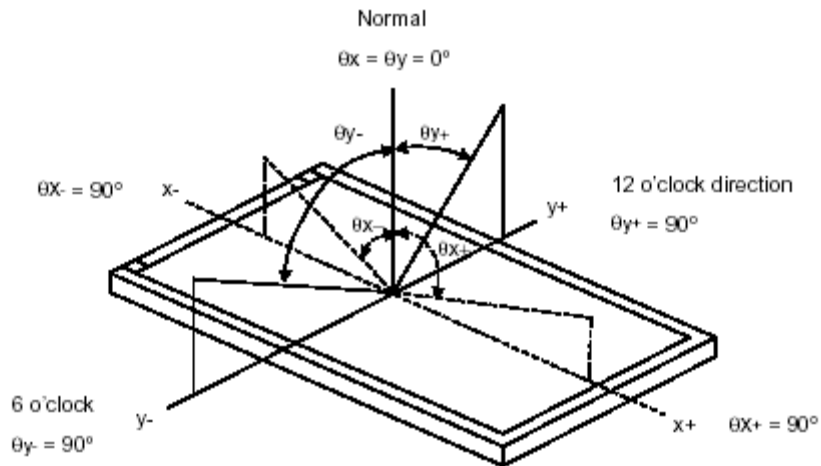

Note 9-4: The definition of response time:

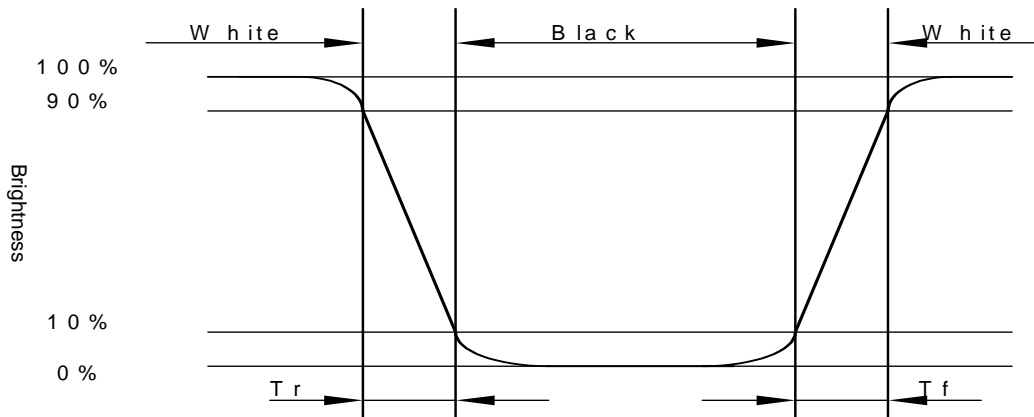

9.2. Testing configuration

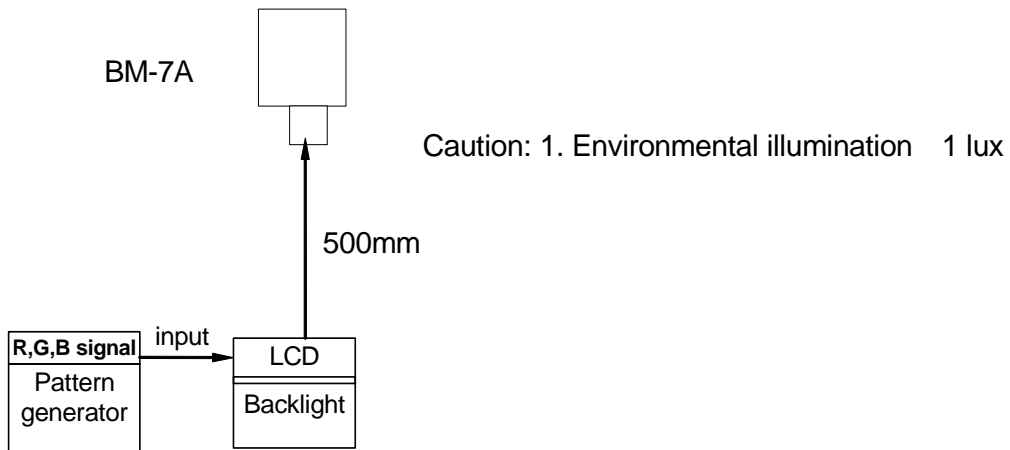

10. TOUCH PANEL CHARACTERISTICS

1. Input Method and Activation Force

Input Method	Average Activation Force
16mm dia. silicon "finger"	80g Max

2. Typical Optical Characteristics

ITEM	Parameter
Visible Light Transmission	80%typ
Haze	5%typ

3. Electrical Specification

ITEM	Parameter
Operating Voltage	DC 7V Max
Contact current	According to individual design
Circuit close resistance	X 200~1000Ω
	Y 100~800Ω
Circuit open resistance	10MΩ at DC25V
Chattering	≤20ms
Linear Test	≤1.5%

4. Linearity

ITEM	Parameter
Linear Test Specification Direction	X 0±1.5%
	Y 0±1.5%

5. Specification

ITEM	Parameter
Operating Temperature	-20°C~+60°C
Storage Temperature	-30°C~+70°C

6. Durability test:

6.1 Finger touches

Touch panel is hit 1 millions times with a silicone rubber of R8 finger, hitting rate is by 200g at 5 times per second. The measurement must satisfy the following:

- Circuit close resistance: x 200~1000Ω ;
y 100~800Ω
- Circuit open resistance: 10MΩ at DC25V
- Contact bounce: ≤20ms
- Linearity test: ≤3%

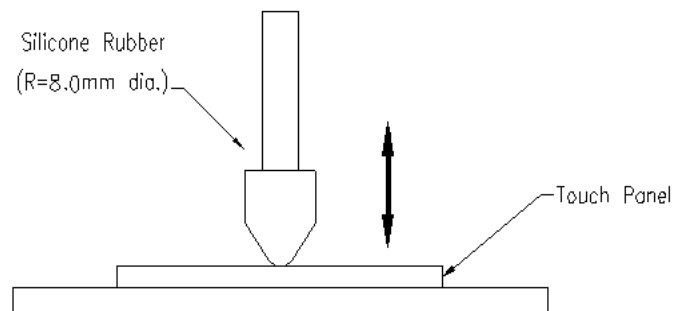

11. QUALITY ASSURANCE

11.1 Test Condition

11.1.1 Temperature and Humidity(Ambient Temperature)

Temperature : $20 \pm 5^{\circ}\text{C}$

Humidity : $65 \pm 5\%$

11.1.2 Operation

Unless specified otherwise, test will be conducted under function state.

11.1.3 Container

Unless specified otherwise, vibration test will be conducted to the product itself without putting it in a container.

11.1.4 Test Frequency

In case of related to deterioration such as shock test. It will be conducted only once.

11.1.5 Test Method

No.	Reliability Test Item & Level	Test Level
1	High Temperature Storage Test	T=70°C,240hrs
2	Low Temperature Storage Test	T=-30°C,240hrs
3	High Temperature Operation Test	T=60°C,240hrs
4	Low Temperature Operation Test	T=-20°C,240hrs
5	High Temperature and High Humidity Operation Test	T=40°C,90% RH,240hrs
6	Temperature Cycle Test (No operation)	-30°C → +25°C → +70°C,50 Cycles 30 min 5min 30 min
7	Vibration Test (No operation)	Frequency:10 ~ 55 Hz Amplitude:1.0 mm Sweep Time:11min Test Period:6 Cycles for each Direction of X,Y,Z
8	Shock Test (No operation)	100G, 6ms Direction : ± X,± Y,± Z Cycle : 3 times

12. LCM PRODUCT LABEL DEFINE

Product Label style:

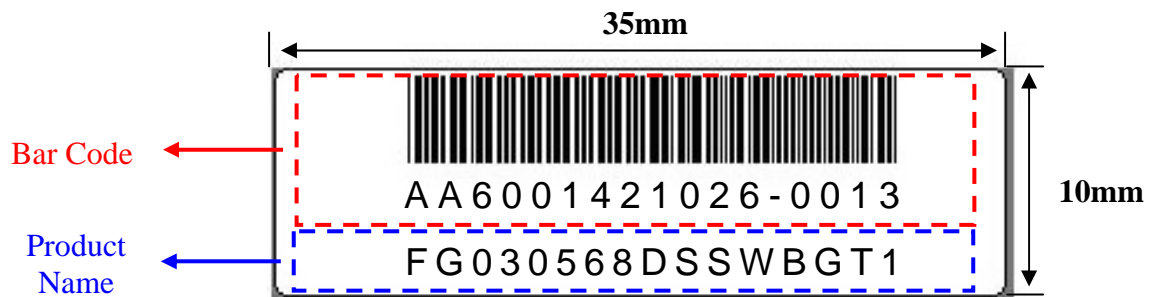

BarCode Define:

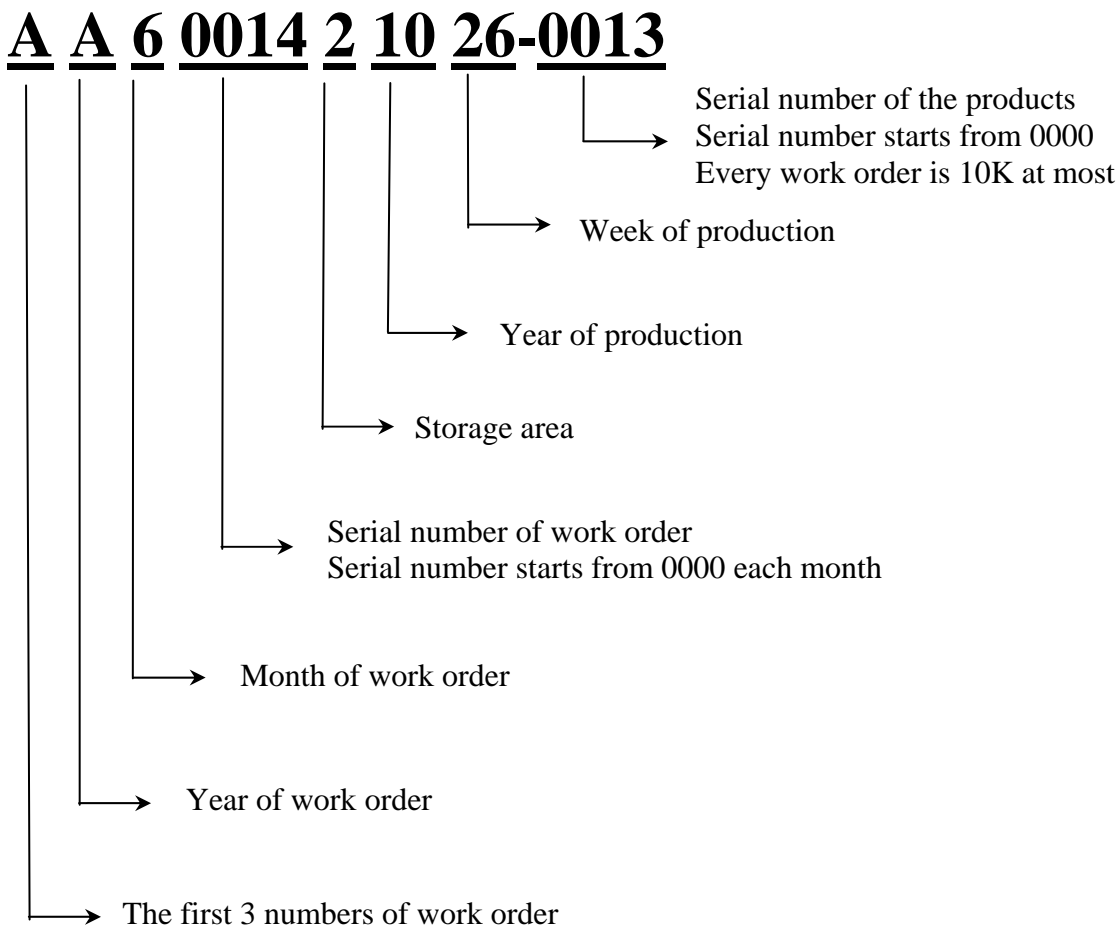

Product Name Define:

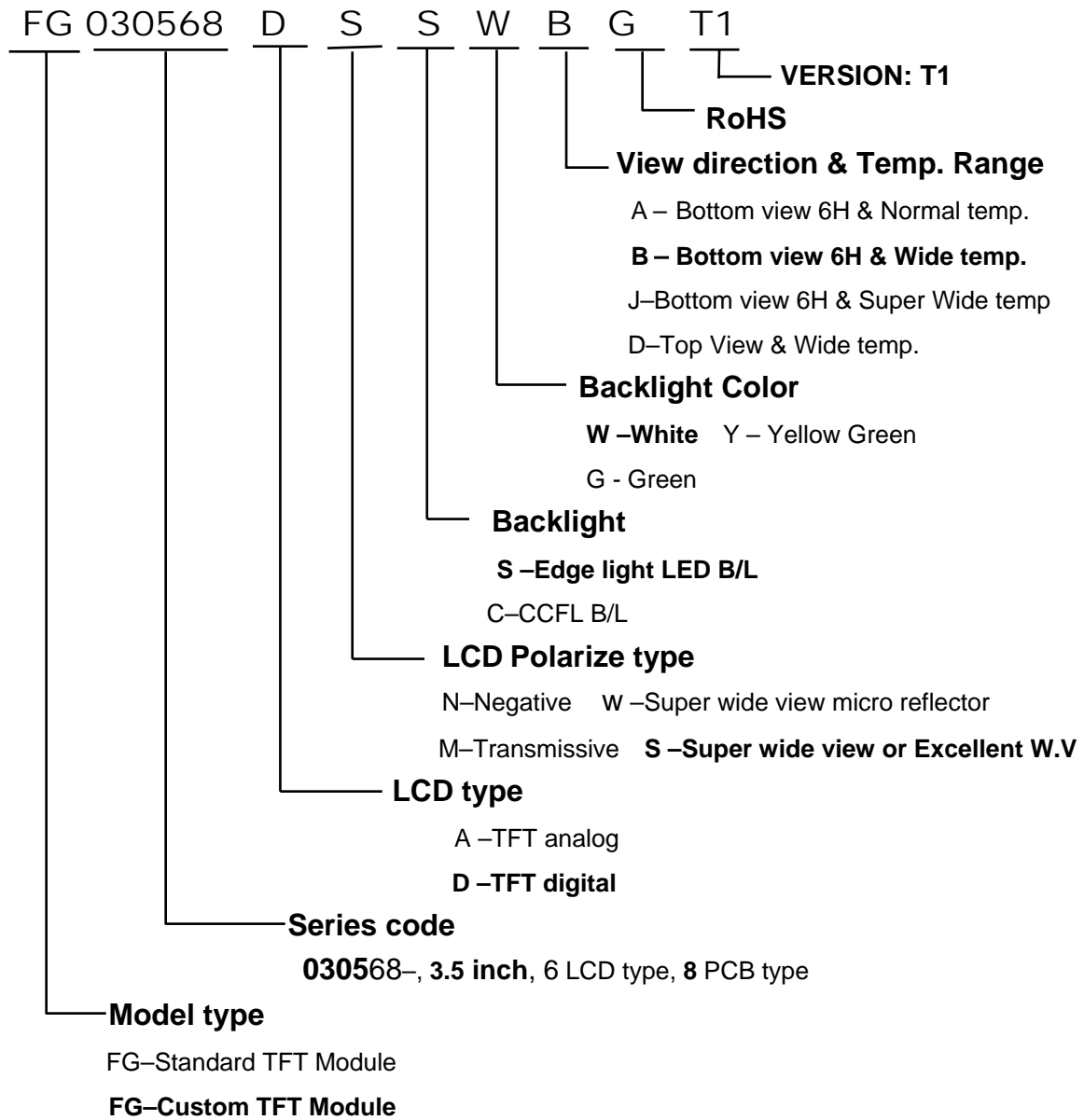

13. PRECAUTIONS IN USE LCM

1. LIQUID CRYSTAL DISPLAY (LCD)

LCD is made up of glass, organic sealant, organic fluid, and polymer based polarizers. The following precautions should be taken when handling,

- (1). Keep the temperature within range of use and storage. Excessive temperature and humidity could cause polarization degradation, polarizer peel off or bubble.
- (2). Do not contact the exposed polarizers with anything harder than an HB pencil lead. To clean dust off the display surface, wipe gently with cotton, chamois or other soft material soaked in petroleum benzin.
- (3). Wipe off saliva or water drops immediately. Contact with water over a long period of time may cause polarizer deformation or color fading, while an active LCD with water condensation on its surface will cause corrosion of ITO electrodes.
- (4). Glass can be easily chipped or cracked from rough handling, especially at corners and edges.
- (5). Do not drive LCD with DC voltage.

2. Liquid Crystal Display Modules

2.1 Mechanical Considerations

LCM are assembled and adjusted with a high degree of precision. Avoid excessive shocks and do not make any alterations or modifications. The following should be noted.

- (1). Do not tamper in any way with the tabs on the metal frame.
- (2). Do not modify the PCB by drilling extra holes, changing its outline, moving its components or modifying its pattern.
- (3). Do not touch the elastomer connector, especially insert an backlight panel (for example, EL).
- (4). When mounting a LCM make sure that the PCB is not under any stress such as bending or twisting. Elastomer contacts are very delicate and missing pixels could result from slight dislocation of any of the elements.
- (5). Avoid pressing on the metal bezel, otherwise the elastomer connector could be deformed and lose contact, resulting in missing pixels.

2.2. Static Electricity

LCM contains CMOS LSI's and the same precaution for such devices should apply, namely

- (1). The operator should be grounded whenever he/she comes into contact with the module. Never touch any of the conductive parts such as the LSI pads, the copper leads on the PCB and the interface terminals with any parts of the human body.
- (2). The modules should be kept in antistatic bags or other containers resistant to static for storage.
- (3). Only properly grounded soldering irons should be used.
- (4). If an electric screwdriver is used, it should be well grounded and shielded from commutator sparks.

(5) The normal static prevention measures should be observed for work clothes and working benches; for the latter conductive (rubber) mat is recommended.

(6). Since dry air is inductive to statics, a relative humidity of 50-60% is recommended.

2.3 Soldering

- (1). Solder only to the I/O terminals.
- (2). Use only soldering irons with proper grounding and no leakage.
- (3). Soldering temperature : $280^{\circ}\text{C} \pm 10^{\circ}\text{C}$
- (4). Soldering time: 3 to 4 sec.
- (5). Use eutectic solder with resin flux fill.
- (6). If flux is used, the LCD surface should be covered to avoid flux spatters. Flux residue should be removed after wards.

2.4 Operation

- (1). The viewing angle can be adjusted by varying the LCD driving voltage V_0 .
- (2). Driving voltage should be kept within specified range; excess voltage shortens display life.
- (3). Response time increases with decrease in temperature.
- (4). Display may turn black or dark blue at temperatures above its operational range; this is (however not pressing on the viewing area) may cause the segments to appear "fractured".
- (5). Mechanical disturbance during operation (such as pressing on the viewing area) may cause the segments to appear "fractured".

2.5 Storage

If any fluid leaks out of a damaged glass cell, wash off any human part that comes into contact with soap and water. Never swallow the fluid. The toxicity is extremely low but caution should be exercised at all the time.

2.6 Limited Warranty

Unless otherwise agreed between DATA IMAGE and customer, DATA IMAGE will replace or repair any of its LCD and LCM which is found to be defective electrically and visually when inspected in accordance with DATA IMAGE acceptance standards, for a period on one year from date of shipment. Confirmation of such date shall be based on freight documents. The warranty liability of DATA IMAGE is limited to repair and/or replacement on the terms set forth above. DATA IMAGE will not responsible for any subsequent or consequential events.

Confidential Document
14. OUTLINE DRAWING

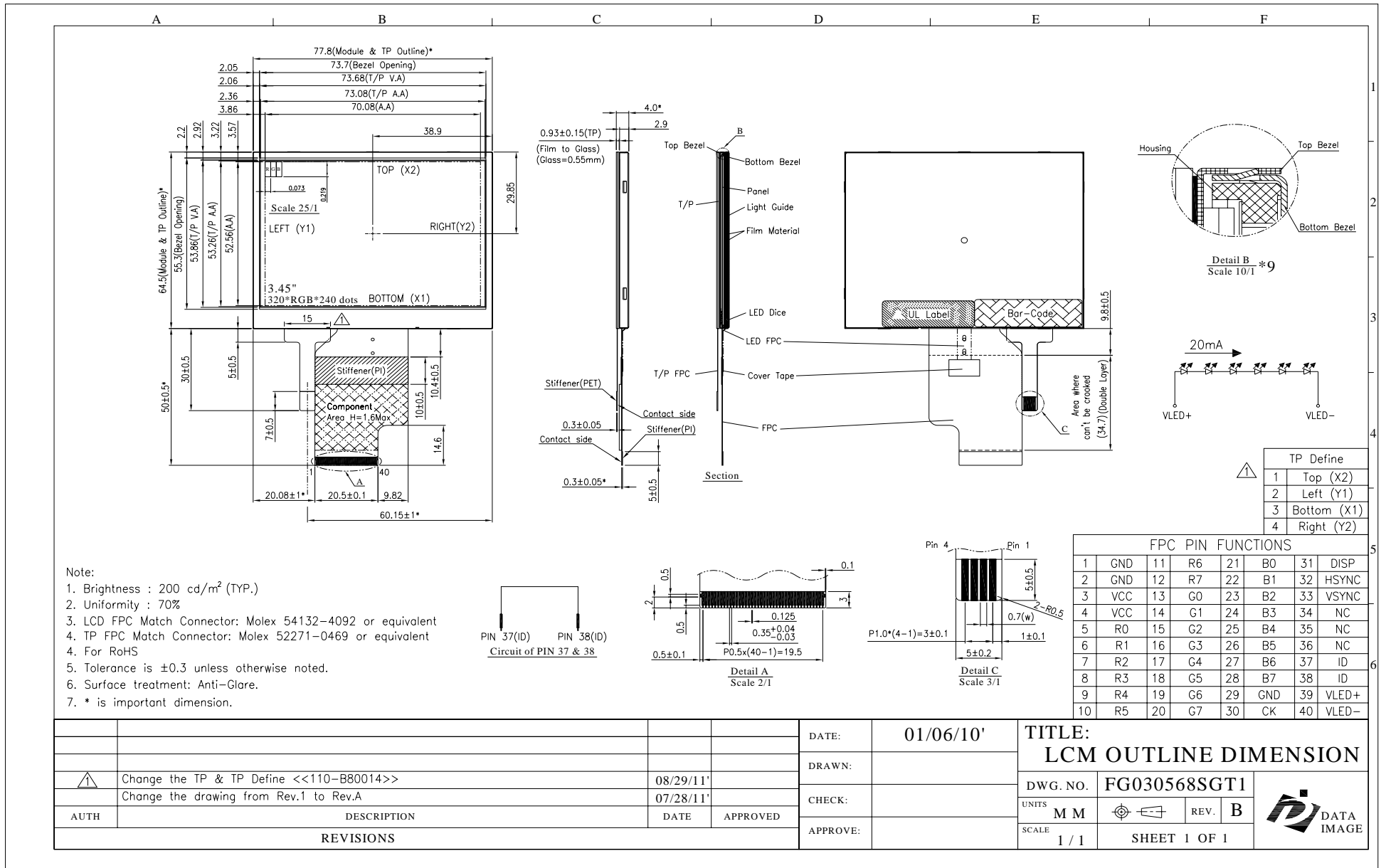

Confidential Document
15. PACKAGE INFORMATION

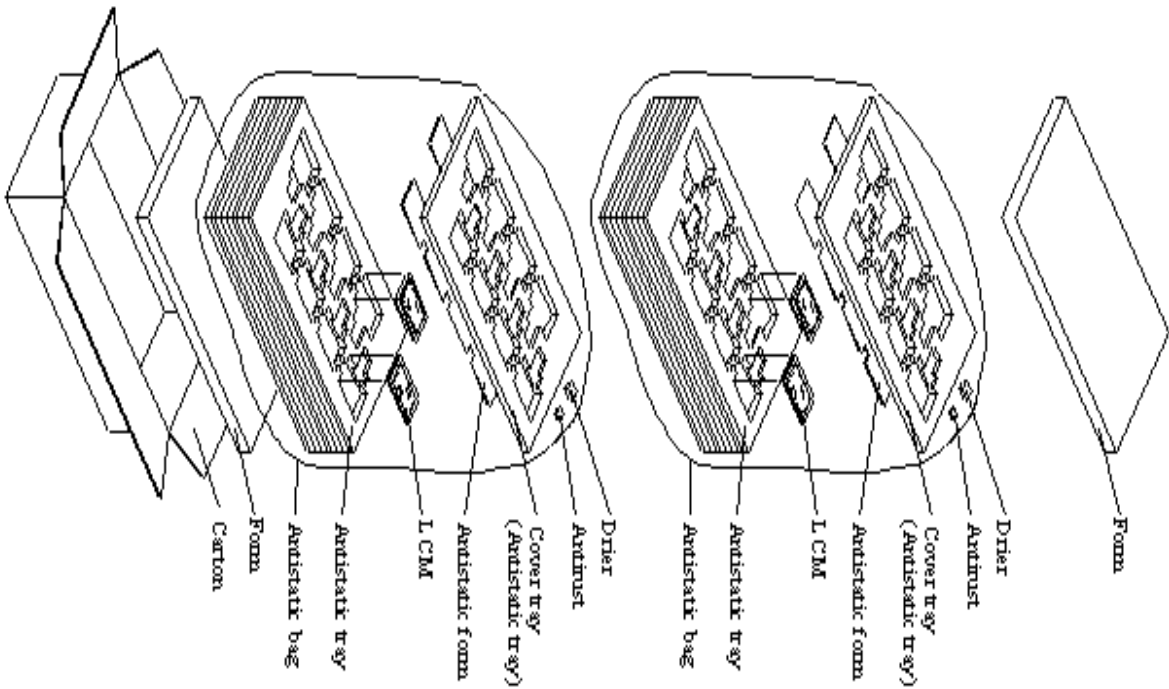

- Material**
- 1 Carton + 2 Anti-static bag + 2 Form(3.5mm)
 - + 36 Anti-static Form+ 20 Anti-static tray + 2 Drier + 2 Antitrust

Total pcs

- 1 Anti-static tray = 8 panel pcs
- 1 Anti-static bag = 9 Anti-static tray + cover tray = 9*8+1*0=72 pcs
- 1 Carton = 2 Anti-static bag = 2*72 = 144 pcs
- 1 Carton = 144 pcs
- Carton size : 485L x 282W x 279H (mm)
- Total Weight ≈ 8.5 kg

FG030568 TFT LCM+T/P PACKING