







DATA IMAGE CORPORATION

TFT Module Specification

ITEM NO.: FG0700G3DSSWBG01

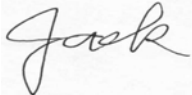
Table of Contents

- 1. COVER & CONTENTS 1
- 2. RECORD OF REVISION 2
- 3. APPLICATION..... 3
- 4. GENERAL SPECIFICATIONS 3
- 5. ABSOLUTE MAXIMUM RATINGS 3
- 6. ELECTRICAL CHARACTERISTICS 3
- 7. INTERFACE SPECIFICATIONS 5
- 8. OPTICAL CHARACTERISTIC 9
- 9. PIN CONNECTIONS 12
- 10. BLOCK DIAGRAM 14
- 11. QUALITY ASSURANCE 15
- 12. LOT NUMBERING SYSTEM 16
- 13. LCM NUMBERING SYSTEM 16
- 14. PRECAUTIONS IN USE LCM 17
- 15. OUTLINE DRAWING 18
- 16. PACKAGE INFORMATION..... 19

Customer Companies	R&D Dept.	Q.C. Dept.	Eng. Dept.	Prod. Dept.
				
Approved by	Version:	Issued Date:	Sheet Code:	Total Pages:
	c	2009/6/11		19

2. RECORD OF REVISION

Rev	Date	Item	Page	Comment
1	22/APR/08			Initial preliminary
2	15/MAY/08	10	14	Modify Block Diagram.
3	5/JUN/08	3,6,8, 15	3,4,9, 18	1. Modify Dot Pitch from 0.1905 (H) x 0.1905 (V) to 0.0635 (H) x 0.1905 (V). 2. Modify "LED life time" to "LED dice life time", value and note 3. Modify Response time value, Rise 15(Typ)30(Max), Fall 20 (Typ) 40(Max) to Rise 5(Typ)10(Max) Fall 15(Typ)20(Max) 4. Modify Temperature cycle test value, from -20 →+25 → +70 , 100 Cycles to -30 →+25 →+80 , 100 Cycles 5. Change OUTLINE DRAWING from rev:1 to rev:2
A	11/SEP/08	4,6,2,8, 15	3,4,9,18	1. Modify LED Current(1+2+3.....+9) to LED current 2. Modify VLED 1,2,3,4,5,6,7,8,9=9.3V(min) to VLED 1,2,3,4,5, 6,7,8, 9=8.4V(min) 3. Add chromaticity values 4. Add weight 132g 5. Change OUTLINE DRAWING from rev:2 to rev: A to rev: B. 6. Add PACKAGE INFORMATION.
B	16/Feb/09	7,19	5,20	Modify THS from STHD[7:0]+88 to 216 Modify TVS from STVD[6:0]+8 to 35 Modify Package information
C	11/JUN/09	6	4	Modify LED dice life time data.

3. APPLICATION

DVD player, Car TV, UMPC, POS

4. GENERAL SPECIFICATIONS

Parameter	Specifications	Unit
Screen Size	7 (diagonal)	inch
Display Format	800(H) x (R,G,B) x 480(V)	dot
Active Area	152.4(H) x 91.44(V)	mm
Dot Pitch	0.0635 (H) x 0.1905 (V)	mm
Pixel Configuration	Stripe	
Outline Dimension	165(W) x 106.4(H) x 3.4 (D)	mm
Surface treatment	Anti-glare and hard coating (3H)	
Back-light	LED	
Display mode	Normally white	
Weight	132	g
View Angle direction	6 o'clock	

5. ABSOLUTE MAXIMUM RATINGS

GND=0V

Parameter	Symbol	MIN.	MAX.	Unit	Remark
Power supply voltage	V _{CC}	-0.3	7	V	Ta=25°C
Logic input voltage	V _I	-0.3	V _{CC} +0.3	V	
Operating temperature	Top	-20	70	°C	Module surface*
Storage temperature	Tst	-30	+80	°C	-
Humidity	Operation	20%~90% relative humidity			Ta<=38°C
	Non Operation	5%~90% relative humidity			Ta<=38°C

6. ELECTRICAL CHARACTERISTICS

6.1 Operating Conditions

GND=0V, fH=31.5KHz, fV=60Hz, fCLK=33.26MHz, Ta=25°C

Parameter	Symbol	MIN.	Typ.	MAX.	Unit	Remark
Power Supply voltage	V _{CC}	3.0	3.3	3.6	V	
Power Supply Current	I _{CC}		150	200	mA	V _{CC} =3.3V
Ripple voltage	V _{RF}	-	-	100	mV _{P-P}	
"H" level logical input voltage	V _{IH}	0.7V _{CC}	--	V _{CC}	V	
"L" level logical input voltage	V _{IL}	0	--	0.3V _{CC}	V	

6.2 Backlight Driving Consumption

 $T_a = 25\text{ }^\circ\text{C}$

Parameter	Symbol	Min.	Typ.	Max.	Unit	Remark
VLED voltage	V_L	8.4	--	10.8	V	Note1
LED current	I_L	-	180	-	mA	
LED dice life time		20,000	30,000		hr	Note2

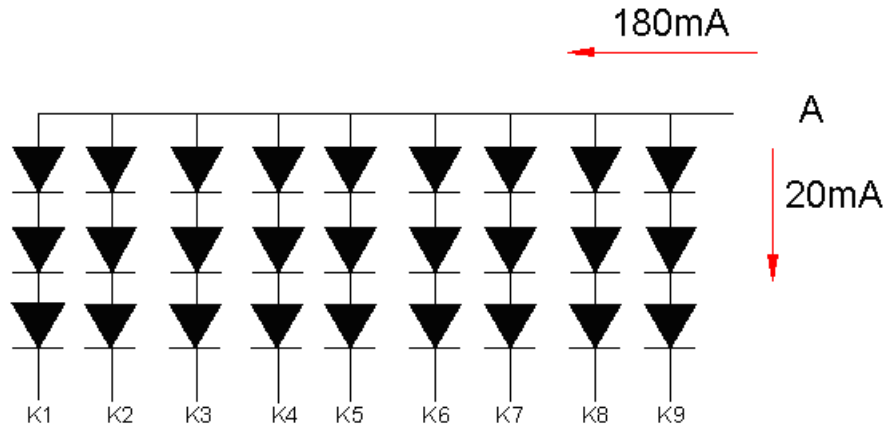

Note1: There are 9 Groups (1 Group of three LEDs).

VLED 1,2,3,4,5,6,7,8,9,=8.4V(min)

Note2: The "LED dice life time" is defined as the brightness decrease to 50% original brightness that the ambient temperature is 18 ~28 and LED dice current=20mA.

7. INPUT SIGNAL CHARACTERISTICS

7.1 AC Characteristics

7.1.1 AC Electrical Characteristics

ITEM	SYMBOL	MIN.	TYP.	MAX.	UNIT
HS setup time	T_{hst}	6	-	-	ns
HS hold time	T_{hhd}	6	-	-	ns
VS setup time	T_{vst}	6	-	-	ns
VS hold time	T_{vhd}	6	-	-	ns
Data setup time	T_{dsu}	6	-	-	ns
Data hold time	T_{dhd}	6	-	-	ns
DE setup time	T_{esu}	6	-	-	ns

7.1.2 Resolution : 800x480

● sync mode

ITEM	SYMBOL	MIN.	TYP.	MAX.	UNIT
CLK frequency	F_{CPH}	-	33.26	-	MHz
CLK period	T_{CPH}	-	30.06	-	ns
CLK pulse duty	T_{CWH}	40	50	60	%
HS period	T_H	-	1056	-	T_{CPH}
HS pulse width	T_{WH}	1	128	-	T_{CPH}
HS-first horizontal data time	T_{HS}	-	216	-	T_{CPH}
HS Active Time	T_{HA}	-	800	-	T_{CPH}
VS period	T_V	-	525	-	T_H
VS pulse width	T_{WV}	1	2	-	T_H
VS-DE time	T_{VS}	-	35	-	T_H
VS Active Time	T_{VA}	-	480	-	T_H

● DE mode

ITEM	SYMBOL	MIN.	TYP.	MAX.	UNIT
CLK frequency	F_{CPH}	-	33.26	-	MHz
CLK period	T_{CPH}	-	30.06	-	ns
CLK pulse duty	T_{CWH}	40	50	60	%
DE period	$T_{DEH}+T_{DEL}$	1000	1056	1200	T_{CPH}
DE pulse width	T_{DH}	-	800	-	T_{CPH}
DE frame blanking	T_{HS}	10	45	110	$T_{DEH}+T_{DEL}$
DE frame width	T_{EP}	-	480	-	$T_{DEH}+T_{DEL}$

ITEM	SYMBOL	MIN.	TYP.	MAX.	UNIT
OEV pulse width	T_{OEV}	-	150	-	T_{CPH}
CKV pulse width	T_{CKV}	-	133	-	T_{CPH}
DE(internal)-STV time	T_1	-	4	-	T_{CPH}
DE(internal)-CKV time	T_2	-	40	-	T_{CPH}
DE(internal)-OEV time	T_3	-	23	-	T_{CPH}
DE(internal)-POL time	T_4	-	157	-	T_{CPH}
STV pulse width	-	-	1	-	T_H

7.2 Timing Controller Timing Chart

7.2.1 Clock and Data input waveforms

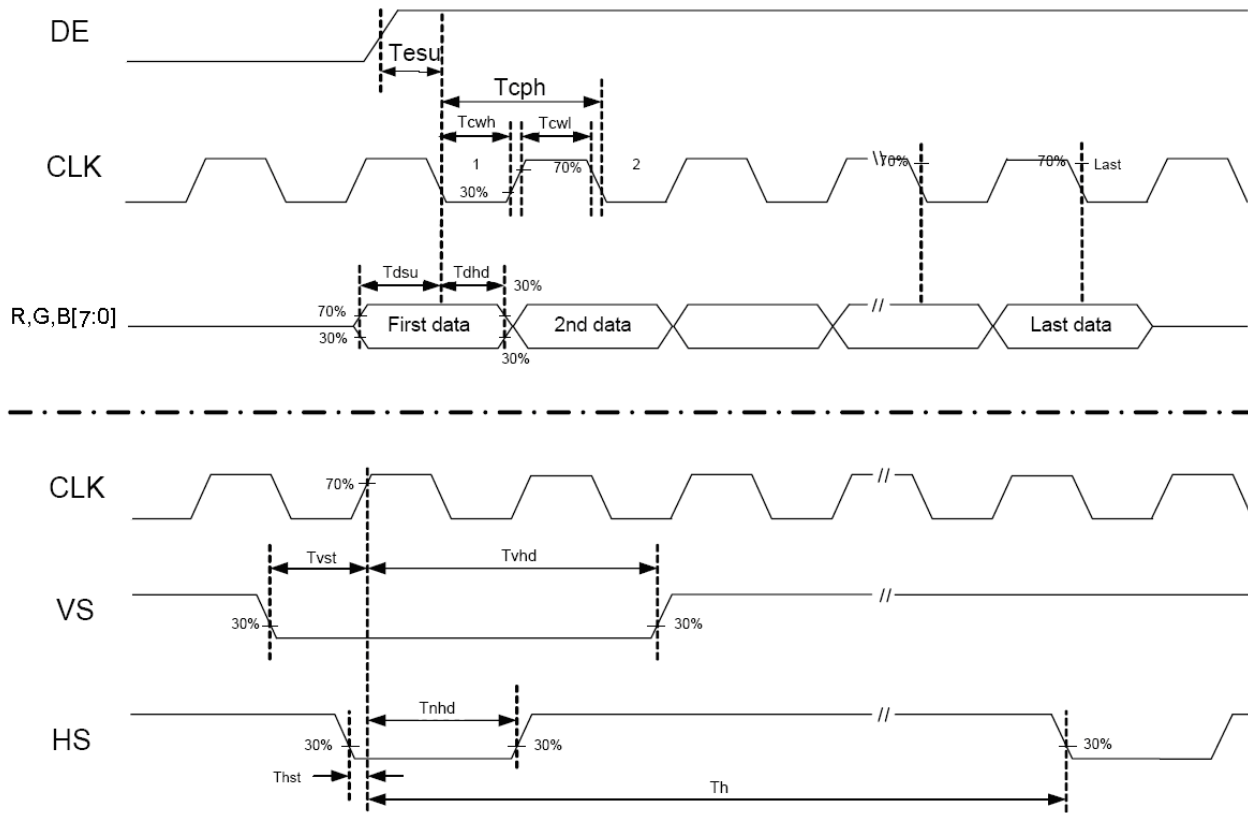

Figure 1 Clock and Data input waveforms.

7.2.2 Data Input format

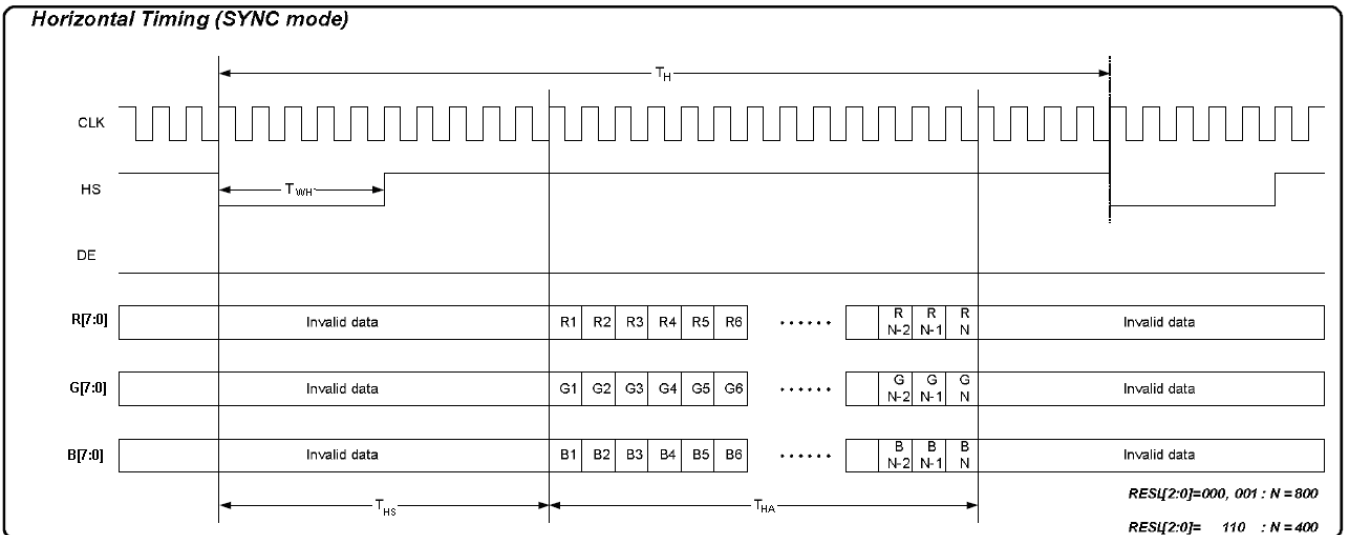
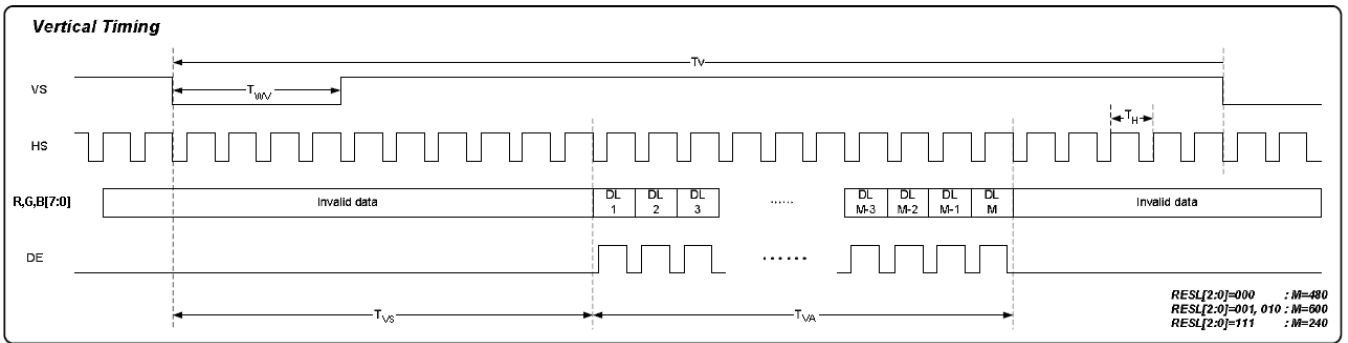
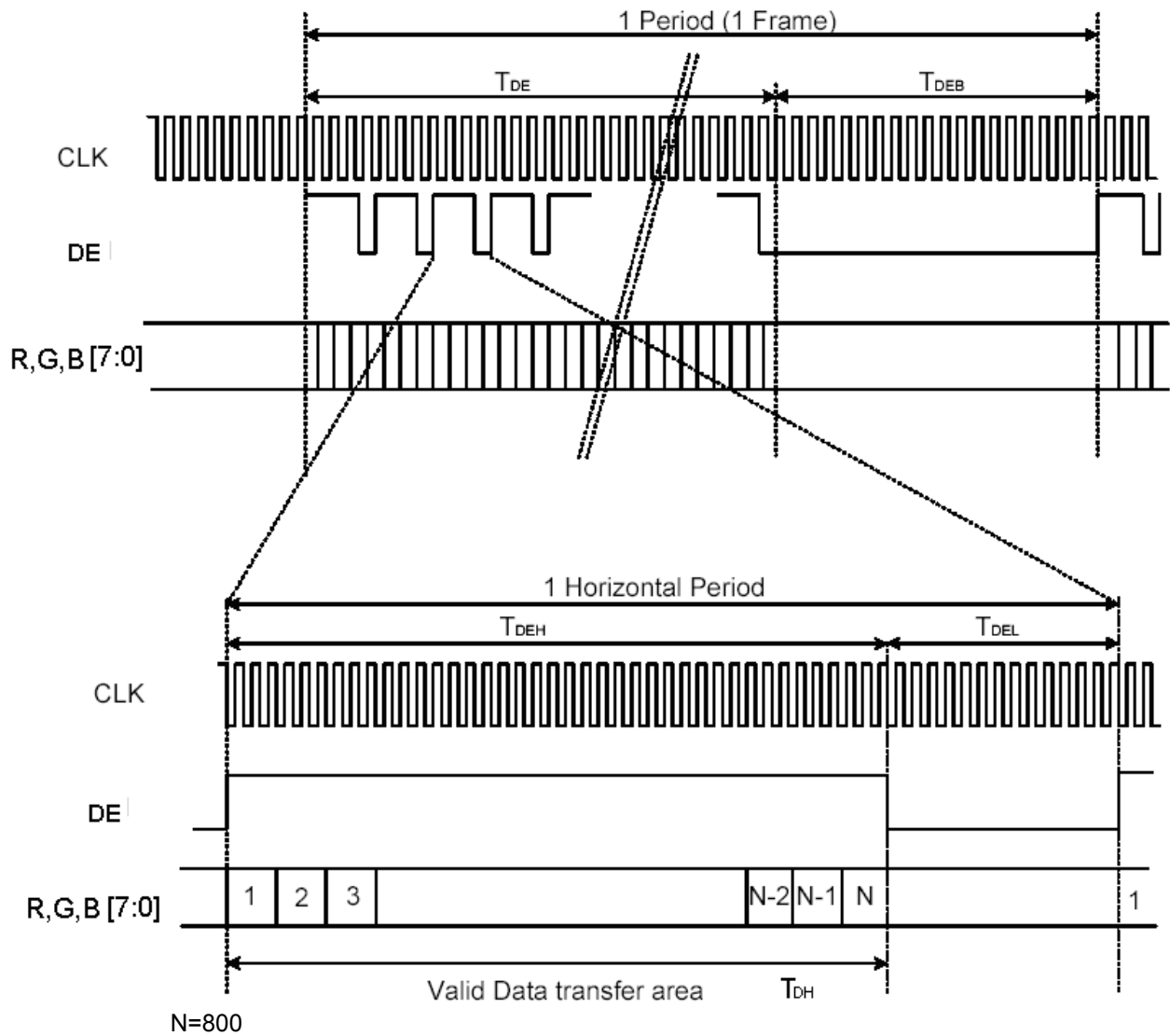

Figure 2 SYNC Mode Horizontal Data Format

Figure 3 SYNC Mode Vertical Data Format
7.2.3 DE Mode Data Format

Figure 4 DE Mode Data Format

7.3 Color Data Input Assignment

COLOR	DISPLAY	DATA SIGNAL																					GRAY SCALE LEVEL			
		RED							GREEN							BLUE										
		R0	R1	R2	R3	R4	R5	R6	R7	G0	G1	G2	G3	G4	G5	G6	G7	B0	B1	B2	B3	B4		B5	B6	B7
BASIC COLOR	BLACK	0	0	0	0	0	0	0	0	0	0	0	0	0	0	0	0	0	0	0	0	0	0	0	-	
	BLUE	0	0	0	0	0	0	0	0	0	0	0	0	0	0	0	0	1	1	1	1	1	1	1	1	-
	GREEN	0	0	0	0	0	0	0	0	1	1	1	1	1	1	1	1	0	0	0	0	0	0	0	0	-
	CYAN	0	0	0	0	0	0	0	0	1	1	1	1	1	1	1	1	1	1	1	1	1	1	1	1	-
	RED	1	1	1	1	1	1	1	1	0	0	0	0	0	0	0	0	0	0	0	0	0	0	0	0	-
	MAGENTA	1	1	1	1	1	1	1	1	0	0	0	0	0	0	0	0	1	1	1	1	1	1	1	1	-
	YELLOW	1	1	1	1	1	1	1	1	1	1	1	1	1	1	1	1	0	0	0	0	0	0	0	0	-
	WHITE	1	1	1	1	1	1	1	1	1	1	1	1	1	1	1	1	1	1	1	1	1	1	1	1	-
GRAY SCALE OF RED	BLACK	0	0	0	0	0	0	0	0	0	0	0	0	0	0	0	0	0	0	0	0	0	0	0	R0	
	DARK ↑	0	0	0	0	0	0	0	0	0	0	0	0	0	0	0	0	0	0	0	0	0	0	0	R1	
		0	1	0	0	0	0	0	0	0	0	0	0	0	0	0	0	0	0	0	0	0	0	0	R2	
		:	:	:	:	:	:	:	:	:	:	:	:	:	:	:	:	:	:	:	:	:	:	:	:	R3~R252
	LIGHT ↓	:	:	:	:	:	:	:	:	:	:	:	:	:	:	:	:	:	:	:	:	:	:	:	:	R3~R252
		1	0	1	1	1	1	1	1	0	0	0	0	0	0	0	0	0	0	0	0	0	0	0	R253	
	0	1	1	1	1	1	1	1	0	0	0	0	0	0	0	0	0	0	0	0	0	0	0	0	R254	
	RED	1	1	1	1	1	1	1	1	0	0	0	0	0	0	0	0	0	0	0	0	0	0	0	R255	
GRAY SCALE OF GREEN	BLACK	0	0	0	0	0	0	0	0	0	0	0	0	0	0	0	0	0	0	0	0	0	0	0	G0	
	DARK ↑	0	0	0	0	0	0	0	0	1	0	0	0	0	0	0	0	0	0	0	0	0	0	0	G1	
		0	0	0	0	0	0	0	0	0	1	0	0	0	0	0	0	0	0	0	0	0	0	0	G2	
		:	:	:	:	:	:	:	:	:	:	:	:	:	:	:	:	:	:	:	:	:	:	:	:	G3~G252
	LIGHT ↓	:	:	:	:	:	:	:	:	:	:	:	:	:	:	:	:	:	:	:	:	:	:	:	:	G3~G252
		0	0	0	0	0	0	0	0	1	0	1	1	1	1	1	1	0	0	0	0	0	0	0	G253	
	0	0	0	0	0	0	0	0	0	1	1	1	1	1	1	1	0	0	0	0	0	0	0	0	G254	
	GREEN	0	0	0	0	0	0	0	0	1	1	1	1	1	1	1	1	0	0	0	0	0	0	0	G255	
GRAY SCALE OF BLUE	BLACK	0	0	0	0	0	0	0	0	0	0	0	0	0	0	0	0	0	0	0	0	0	0	0	B0	
	DARK ↑	0	0	0	0	0	0	0	0	0	0	0	0	0	0	0	0	1	0	0	0	0	0	0	B1	
		0	0	0	0	0	0	0	0	0	0	0	0	0	0	0	0	0	1	0	0	0	0	0	B2	
		:	:	:	:	:	:	:	:	:	:	:	:	:	:	:	:	:	:	:	:	:	:	:	:	B3~B252
	LIGHT ↓	:	:	:	:	:	:	:	:	:	:	:	:	:	:	:	:	:	:	:	:	:	:	:	:	B3~B252
		0	0	0	0	0	0	0	0	0	0	0	0	0	0	0	0	1	0	1	1	1	1	1	B253	
	0	0	0	0	0	0	0	0	0	0	0	0	0	0	0	0	0	1	1	1	1	1	1	1	B254	
	BLUE	0	0	0	0	0	0	0	0	0	0	0	0	0	0	0	0	1	1	1	1	1	1	1	B255	

Note) Definition of Gray :

R_n : Red Gray, G_n : Green Gray, B_n : Blue Gray (n = Gray level)

Input Signal : 0 = Low level voltage, 1 = High level voltage

8. OPTICAL CHARACTERISTIC

Parameter	Symbol	Condition	MIN.	TYP.	MAX.	Unit	Remarks
Viewing Angle	Horizontal	θ_{x+}	60	70	--	deg	Note 1,4
		θ_{x-}	60	70	--		
	Vertical	θ_{y+}	40	50	--		
		θ_{y-}	50	60	--		
Contrast Ratio	CR	at optimized viewing angle	300	400	--		Note 1,3
Response time	Rise	Tr	-	5	10	ms	Note 1,6
	Fall	Tf	-	15	20	ms	
Uniformity	B-uni	$\theta_x=\theta_y=0^\circ$	70	80	--	%	Note1,5
Brightness	L	$\theta_x=\theta_y=0^\circ$	270	350	--	cd/m ²	Note 1,2
Chromaticity	x_W	Center $\theta_x=\theta_y=0^\circ$	0.252	0.302	0.352		Note 1,7
	y_W		0.289	0.339	0.389		
	x_R		0.525	0.575	0.625		
	y_R		0.310	0.360	0.410		
	x_G		0.281	0.331	0.381		
	y_G		0.521	0.571	0.621		
	x_B		0.099	0.149	0.199		
	y_B		0.088	0.138	0.188		
Image sticking	tis	2 hours			2	Sec	Note 8

The following optical specifications shall be measured in a darkroom or equivalent state (ambient luminance ≤ 1 lux, and at room temperature).

The operation temperature is $25^\circ\text{C} \pm 2^\circ\text{C}$ and LED Backlight Current $I_L=180\text{mA}$.

The measurement method is shown in Note1.

Note1: The method of optical measurement:

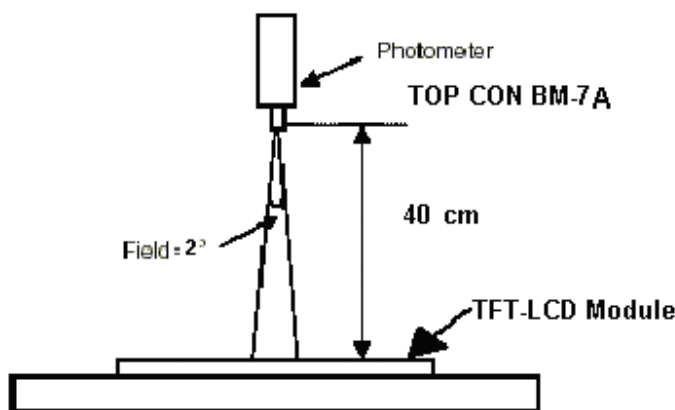

Note2: Measured at the center area of the panel and at the viewing angle of the $\theta_x = \theta_y = 0^\circ$

Note3: Definition of Contrast Ratio (CR):

$$CR = \frac{\text{Luminance with all pixels in white state}}{\text{Luminance with all pixels in Black state}}$$

Note4: Definition of Viewing Angle

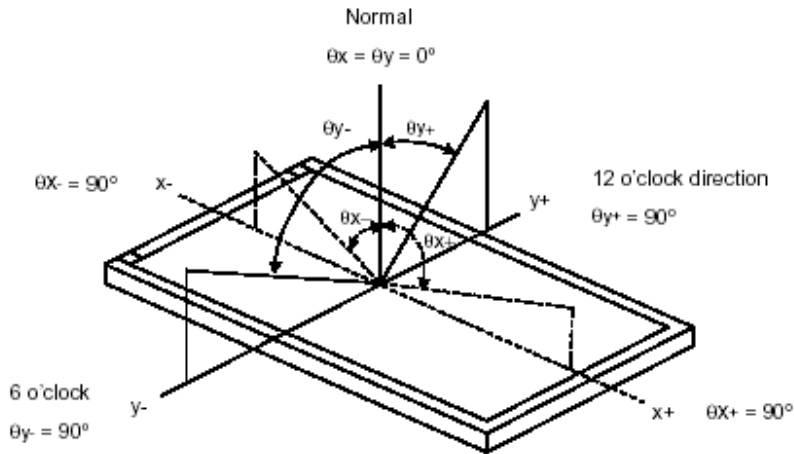

Note 5: Definition of Brightness Uniformity (B-uni):

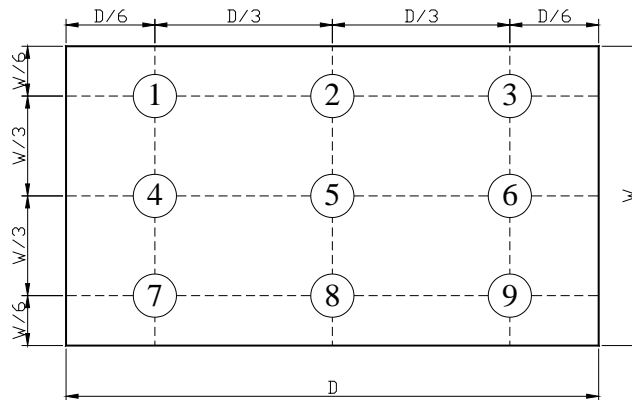

$$B\text{-uni} = \frac{\text{Minimum luminance of 9 points}}{\text{Maximum luminance of 9 points}} \quad (\text{Note 5}).$$

Note6: Definition of Response Time:

The Response Time is set initially by defining the "Rising Time (T_r)" and the "Falling Time (T_f)" respectively. T_r and T_f are defined as following figure.

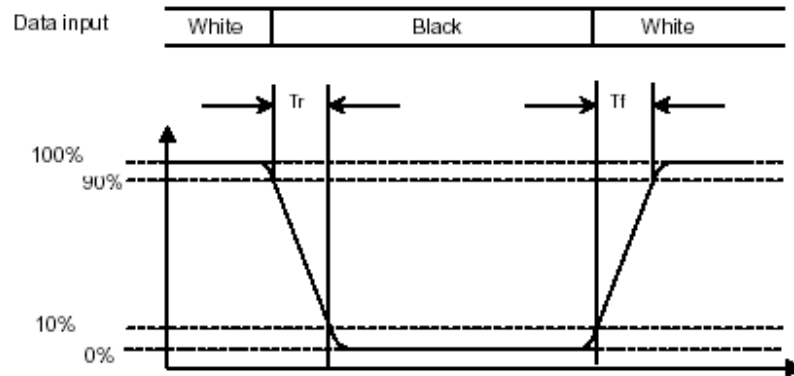

Note 7: Definition of Chromaticity:

The color coordinates (x_w, y_w) , (x_r, y_r) , (x_g, y_g) , and (x_b, y_b) are obtained with all pixels in the viewing field at white, red, green, and blue states, respectively.

Note 8: Definition of Image sticking (tis):

Continuously display the test pattern shown in the figure below for 2 hours. Then display a completely white screen. The previous image shall not persist more than 2 sec at 25 °C

Image sticking pattern

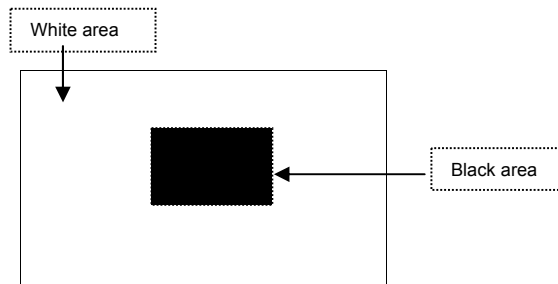

9. PIN CONNECTIONS

Pin NO.	SYMBOL	DESCRIPTION
1	GND	Power Ground
2	GND	Power Ground
3	VCC	Power Supply for Digital Circuit
4	VCC	Power Supply for Digital Circuit
5	R0	Red Data 0 (LSB)
6	R1	Red Data 1
7	R2	Red Data 2
8	R3	Red Data 3
9	R4	Red Data 4
10	R5	Red Data 5
11	R6	Red Data 6
12	R7	Red Data 7 (MSB)
13	G0	Green Data 0 (LSB)
14	G1	Green Data 1
15	G2	Green Data 2
16	G3	Green Data 3
17	G4	Green Data 4
18	G5	Green Data 5
19	G6	Green Data 6
20	G7	Green Data 7 (MSB)
21	B0	Blue Data 0 (LSB)
22	B1	Blue Data 1
23	B2	Blue Data 2
24	B3	Blue Data 3
25	B4	Blue Data 4
26	B5	Blue Data 5
27	B6	Blue Data 6
28	B7	Blue Data 7 (MSB)
29	GND	Power Ground
30	CLK	Clock Signals ; Latch Data at the Falling Edge
31	NC	No connection
32	HS	Horizontal synchronous signal
33	VS	Vertical synchronous signal
34	DE	Data Enable Signal
35	NC	No connection
36	NC	No connection
37	GND	Power Ground
38	GND	Power Ground
39	NC	No connection
40	NC	No connection

Remarks:

Power Signal sequence:

$t_1 \leq 10\text{ms}$; $1 \text{ sec} \leq t_5$

$50\text{ms} \leq t_2$;

$0 < t_3 \leq 50\text{ms}$;

$0 < t_4 \leq 10\text{ms}$

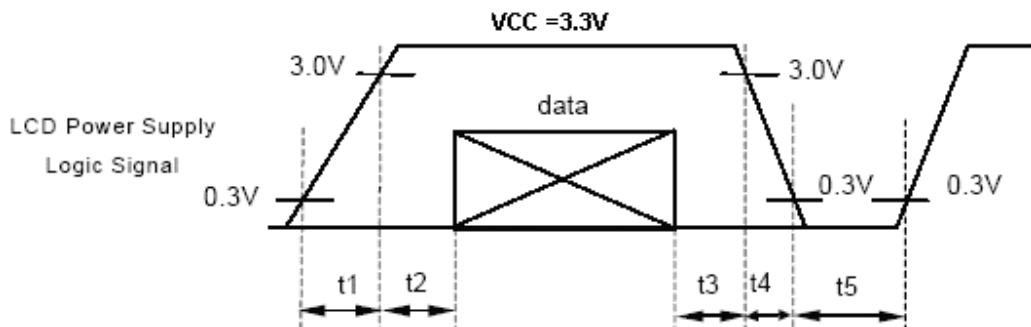

VCC -dip condition:

(1) $2.7\text{V} \leq \text{VCC} \leq 3.0\text{V}$: $t_d \leq 10 \text{ ms}$

(2) $\text{VCC} > 3.0\text{V}$: VCC -dip condition should be the same with VCC,-turn-on condition.

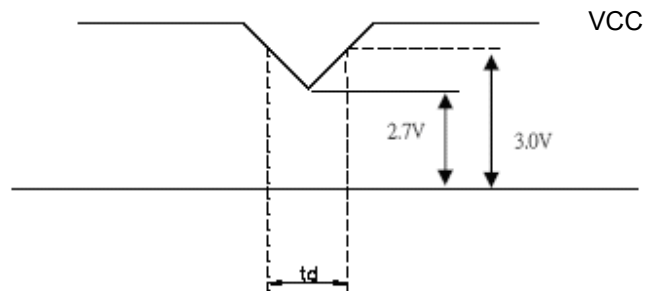

10. BLOCK DIAGRAM

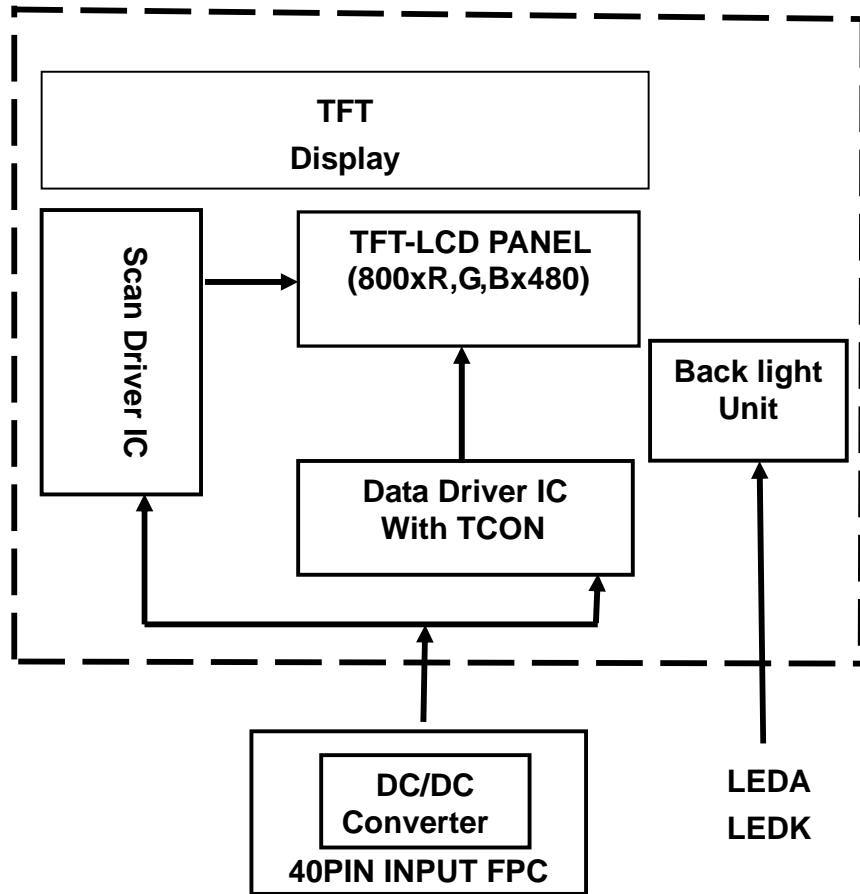

11. QUALITY ASSURANCE

11.1 Test Condition

11.1.1 Temperature and Humidity(Ambient Temperature)

Temperature : $25 \pm 5^{\circ}\text{C}$

Humidity : $65 \pm 5\%$

11.1.2 Operation

Unless specified otherwise, test will be conducted under function state.

11.1.3 Container

Unless specified otherwise, vibration test will be conducted to the product itself without putting it in a container.

11.1.4 Test Frequency

In case of related to deterioration such as shock test. It will be conducted only once.

11.1.5 Test Method

Reliability Test Item & Level		Test Level
No.	Test Item	
1	High Temperature Storage Test	T=80 ,240hrs
2	Low Temperature Storage Test	T=-30 ,240hrs
3	High Temperature Operation Test	T=70 ,240hrs
4	Low Temperature Operation Test	T=-20 ,240hrs
5	High Temperature and High Humidity (No operation)	T=60 ,90%RH,240hrs
6	Thermal Cycling Test (No operation)	-30 → +25 → +80 , 100 Cycles 30 min 5 min 30 min
7	Vibration Test (No operation)	Frequency :10 ~ 55 Hz Amplitude :1.5 mm Sweep time : 11 mins Test Period: 6 Cycles for each direction of X, Y, Z
8	Shock Test (No operation)	100G, 6ms Direction: ±X, ±Y, ±Z Cycle: 3 times

11.2 Judgment standard

The Judgment of the above test should be made as follow:

Pass: Normal display image with no obvious non-uniformity and no line defect. Partial transformation of the module parts should be ignored.

Fail: No display image, obvious non-uniformity, or line defect.

12. LOT NUMBERING SYSTEM

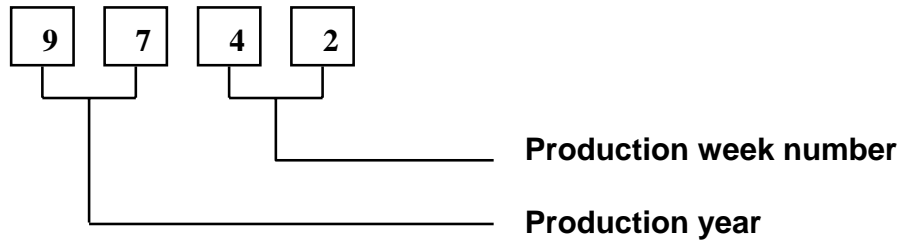

13. LCM NUMBERING SYSTEM

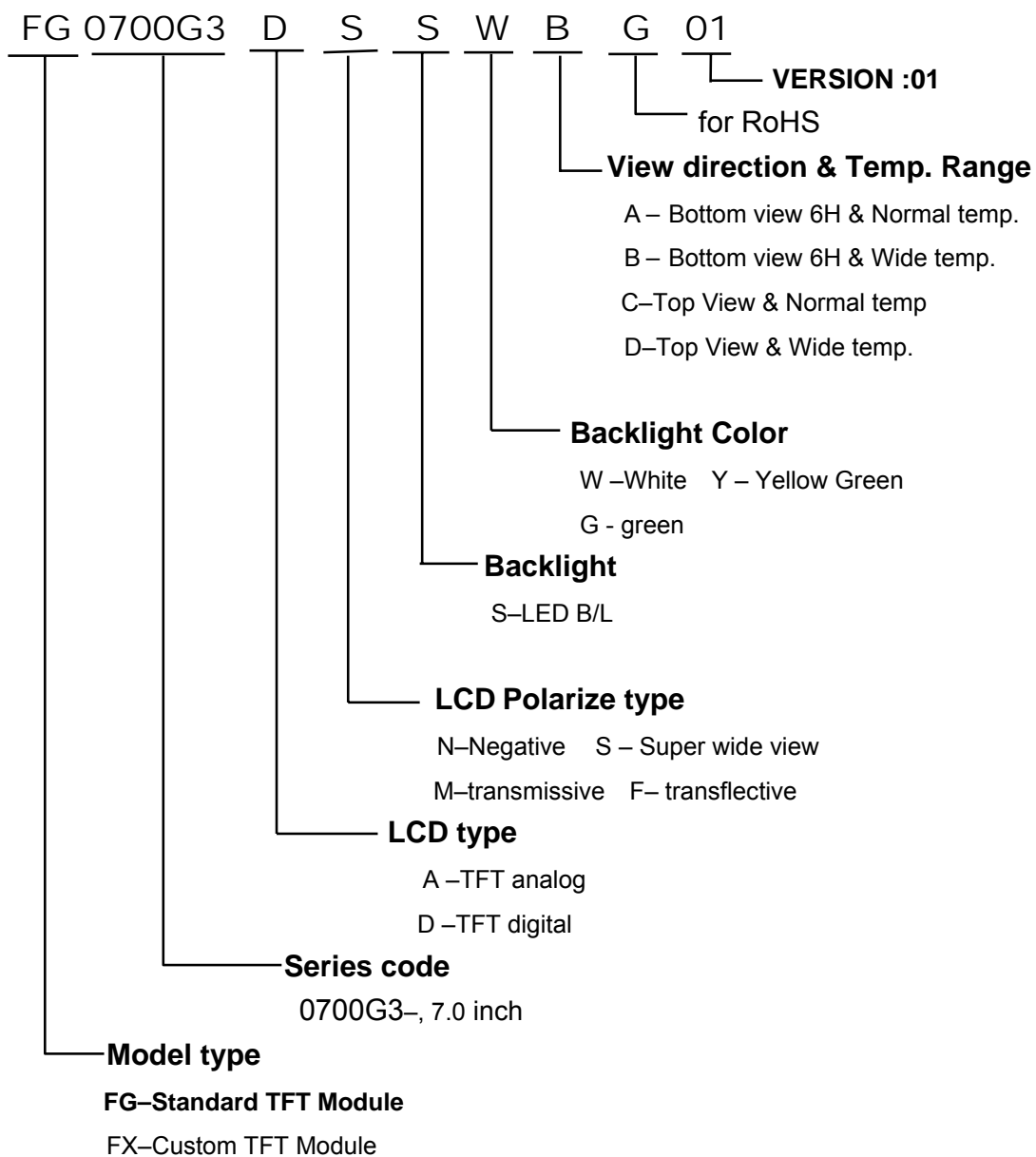

14. PRECAUTION IN USE LCM

1. LIQUID CRYSTAL DISPLAY (LCD)

LCD is made up of glass, organic sealant, organic fluid, and polymer based polarizers. The following precautions should be taken when handling,

- (1). Keep the temperature within range of use and storage. Excessive temperature and humidity could cause polarization degradation, polarizer peel off or bubble.
- (2). Do not contact the exposed polarizers with anything harder than an HB pencil lead. To clean dust off the display surface, wipe gently with cotton, chamois or other soft material soaked in petroleum benzin.
- (3). Wipe off saliva or water drops immediately. Contact with water over a long period of time may cause polarizer deformation or color fading, while an active LCD with water condensation on its surface will cause corrosion of ITO electrodes.
- (4). Glass can be easily chipped or cracked from rough handling, especially at corners and edges.
- (5). Do not drive LCD with DC voltage.

2. Liquid Crystal Display Modules

2.1 Mechanical Considerations

LCM are assembled and adjusted with a high degree of precision. Avoid excessive shocks and do not make any alterations or modifications. The following should be noted.

- (1). Do not tamper in any way with the tabs on the metal frame.
- (2). Do not modify the PCB by drilling extra holes, changing its outline, moving its components or modifying its pattern.
- (3). Do not touch the elastomer connector, especially insert an backlight panel (for example, EL).
- (4). When mounting a LCM make sure that the PCB is not under any stress such as bending or twisting. Elastomer contacts are very delicate and missing pixels could result from slight dislocation of any of the elements.
- (5). Avoid pressing on the metal bezel, otherwise the elastomer connector could be deformed and lose contact, resulting in missing pixels.

2.2. Static Electricity

LCM contains CMOS LSI's and the same precaution for such devices should apply, namely

- (1). The operator should be grounded whenever he/she comes into contact with the module. Never touch any of the conductive parts such as the LSI pads, the copper leads on the PCB and the interface terminals with any parts of the human body.
- (2). The modules should be kept in antistatic bags or other containers resistant to static for storage.
- (3). Only properly grounded soldering irons should be used.
- (4). If an electric screwdriver is used, it should be well grounded and shielded from commutator sparks.

- (5) The normal static prevention measures should be observed for work clothes and working benches; for the latter conductive (rubber) mat is recommended.
- (6). Since dry air is inductive to statics, a relative humidity of 50-60% is recommended.

2.3 Soldering

- (1). Solder only to the I/O terminals.
- (2). Use only soldering irons with proper grounding and no leakage.
- (3). Soldering temperature : $280^{\circ}\text{C} \pm 10^{\circ}\text{C}$
- (4). Soldering time: 3 to 4 sec.
- (5). Use eutectic solder with resin flux fill.
- (6). If flux is used, the LCD surface should be covered to avoid flux spatters. Flux residue should be removed after wards.

2.4 Operation

- (1). The viewing angle can be adjusted by varying the LCD driving voltage V0.
- (2). Driving voltage should be kept within specified range; excess voltage shortens display life.
- (3). Response time increases with decrease in temperature.
- (4). Display may turn black or dark blue at temperatures above its operational range; this is (however not pressing on the viewing area) may cause the segments to appear "fractured".
- (5). Mechanical disturbance during operation (such as pressing on the viewing area) may cause the segments to appear "fractured".

2.5 Storage

If any fluid leaks out of a damaged glass cell, wash off any human part that comes into contact with soap and water. Never swallow the fluid. The toxicity is extremely low but caution should be exercised at all the time.

2.6 Limited Warranty

Unless otherwise agreed between DATA IMAGE and customer, DATA IMAGE will replace or repair any of its LCD and LCM which is found to be defective electrically and visually when inspected in accordance with DATA IMAGE acceptance standards, for a period on one year from date of shipment. Confirmation of such date shall be based on freight documents. The warranty liability of DATA IMAGE is limited to repair and/or replacement on the terms set forth above. DATA IMAGE will not responsible for any subsequent or consequential events.

Confidential Document
15. OUTLINE DRAWING

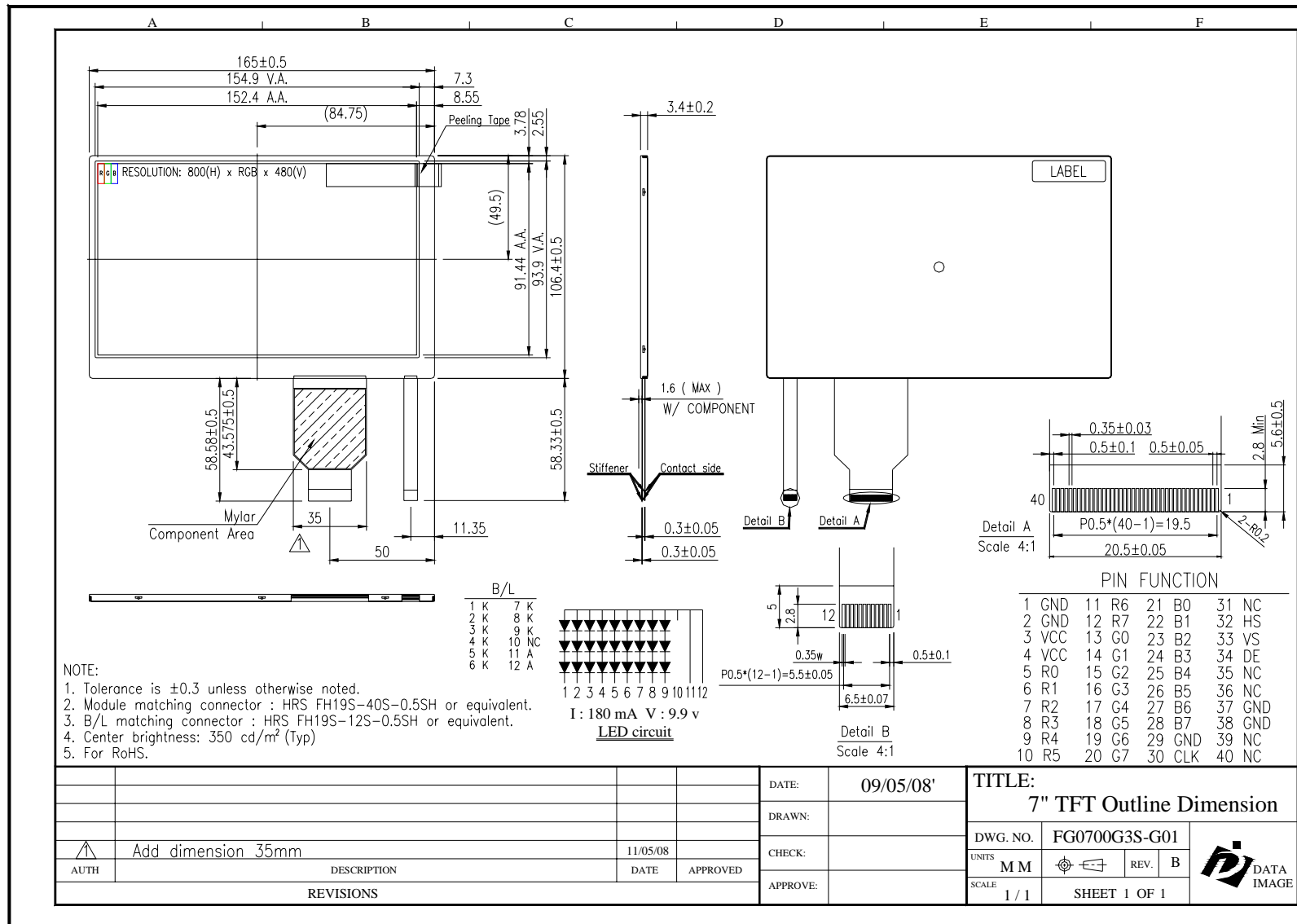

16. PACKAGE INFORMATION

