



# DATA IMAGE CORPORATION

## TFT Module Specification

Preliminary

ITEM NO.: FG0700K3DSSWBG01

### Table of Contents

1. COVER & CONTENTS .....	1
2. RECORD OF REVISION .....	2
3. APPLICATION.....	3
4. GENERAL SPECIFICATIONS .....	3
5. ABSOLUTE MAXIMUM RATINGS .....	3
6. ELECTRICAL CHARACTERISTICS .....	3
7. INTERFACE SPECIFICATIONS .....	4
8. OPTICAL CHARACTERISTIC .....	7
9. PIN CONNECTIONS .....	10
10. BLOCK DIAGRAM .....	12
11. QUALITY ASSURANCE .....	13
12. LOT NUMBERING SYSTEM .....	14
13. LCM NUMBERING SYSTEM .....	14
14. PRECAUTIONS IN USE LCM .....	15
15. OUTLINE DRAWING .....	16
16. PACKAGE INFORMATION.....	17

Customer Companies	R&D Dept.	Q.C. Dept.	Eng. Dept.	Prod. Dept.
	JACK	ERIC	PAUL	HELEN
Approved by	Version:	Issued Date:	Sheet Code:	Total Pages:
	1	2010/4/6		17



## 2. RECORD OF REVISION

Rev	Date	Item	Page	Comment
1	6/April/10'			Initial Preliminary

### 3. APPLICATION

DVD player, Car TV, UMPC, POS

### 4. GENERAL SPECIFICATIONS

Parameter	Specifications	Unit
Screen Size	7 (diagonal)	inch
Display Format	800(H) x (R,G,B) x 480(V)	dot
Active Area	152.4(H) x 91.44(V)	mm
Dot Pitch	0.0635 (H) x 0.1905 (V)	mm
Pixel Configuration	Stripe	
Outline Dimension	165(W) x 104(H) x 6.44 (D) Max	mm
Surface treatment	Anti-glare	
Back-light	LED	
Display mode	Normally white	
Weight	TBD	g
View Angle direction	6 o'clock	

### 5. ABSOLUTE MAXIMUM RATINGS

Parameter	Symbol	MIN.	MAX.	Unit	Remark
Power supply voltage	V <sub>CC</sub> , V <sub>DD</sub>	-0.3	6	V	Ta=25°C
Logic input voltage	V <sub>I</sub>	-0.3	V <sub>CC</sub> +0.3	V	
Operating temperature	Top	-20	+70	°C	Module surface*
Storage temperature	T <sub>st</sub>	-30	+80	°C	-
Humidity	Operation	20%~90% relative humidity			Ta<=38°C
	Non Operation	5%~90% relative humidity			Ta<=38°C

### 6. ELECTRICAL CHARACTERISTICS

f<sub>H</sub>=30KHz, f<sub>V</sub>=60Hz, f<sub>CLK</sub>=33.26,MHz, Ta=25°C

Parameter	Symbol	MIN.	TYP.	MAX.	Unit	Remark
Power Supply voltage for LCD	V <sub>CC</sub>	3.0	3.3	3.6	V	
Power Supply Current for LCD	I <sub>CC</sub>		150	200	mA	V <sub>CC</sub> =3.3V
Power Supply voltage for LED	V <sub>DD</sub>	3.0	3.3	5.5	V	
Power Supply Current for LED	I <sub>DD</sub>	--	TBD	TBD	mA	V <sub>DD</sub> =5.0V
"H" level logical input voltage	V <sub>IH</sub>	0.7V <sub>CC</sub>	--	V <sub>CC</sub>	V	
"L" level logical input voltage	V <sub>IL</sub>	0	--	0.3V <sub>CC</sub>	V	
ADJ frequency		19K	20K	21K	Hz	
ADJ input voltage	V <sub>IH</sub>	3.0	-	3.3	V	
	V <sub>IL</sub>	0	-	0.3	V	
LED dice life time			30000		Hr	Note 1

Note 1: The "LED dice life time" is defined as the brightness decrease to 50% original brightness that the ambient temperature is 18 ~28 and LED dice current=20mA.

## 7. INPUT SIGNAL CHARACTERISTICS

### 7.1 Input signal characteristics

#### 7.1.1 AC Electrical Characteristics

Parameter	Symbol	MIN.	TYP.	MAX.	Unit
Data setup time	$T_{dsu}$	6	-	-	ns
Data hold time	$T_{dhd}$	6	-	-	ns
DE setup time	$T_{esu}$	6	-	-	ns

#### 7.1.2 Resolution :

Parameter	Symbol	MIN.	TYP.	MAX.	Unit
DCLK frequency	$F_{CPH}$	-	33.26	-	MHz
DCLK period	$T_{CPH}$	-	30.06	-	ns
DCLK pulse duty	$T_{CWH}$	40	50	60	%
DE period	$T_{DEH}+T_{DEL}$	1000	1056	1200	$T_{CPH}$
DE pulse width	$T_{DH}$	-	800	-	$T_{CPH}$
DE frame blanking	$T_{DEB}$	10	45	110	$T_{DEH}+T_{DEL}$
DE frame width	$T_{DE}$	-	480	-	$T_{DEH}+T_{DEL}$

## 7.2 Timing Controller Timing Chart

### 7.2.1 Clock and Data input waveforms

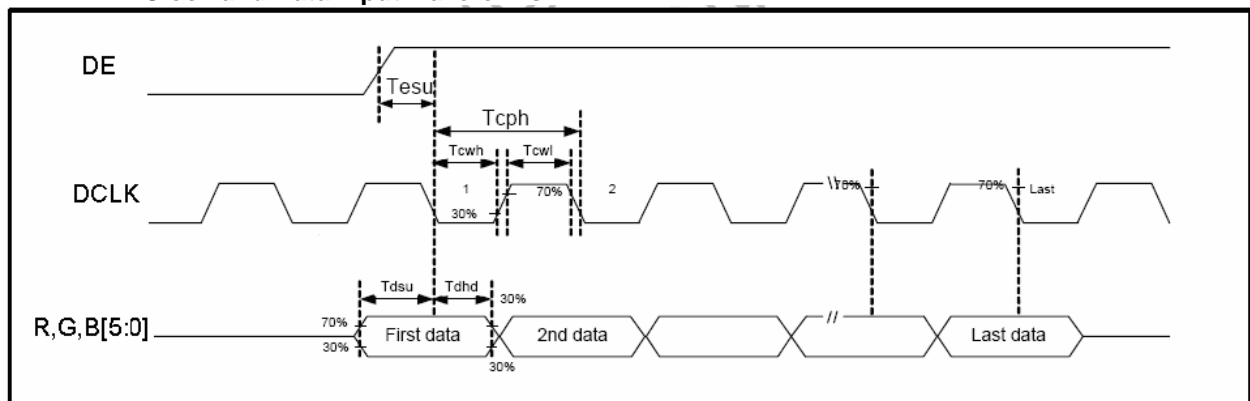

Figure 1 Clock and Data input waveforms.

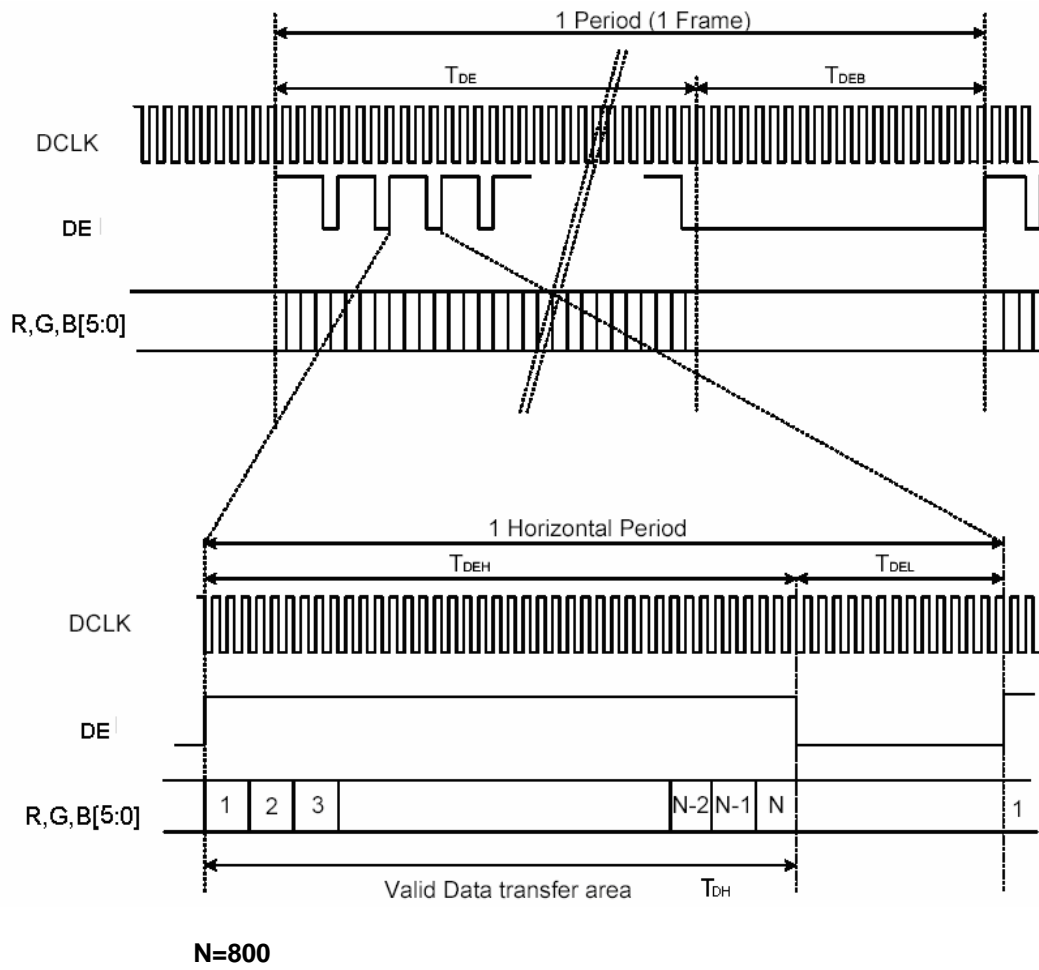

Figure 2 DE Mode Data Format

### 7.3 Color Data Input Assignment

		Data Signal																	
		Red					Green					Blue							
Color		R5	R4	R3	R2	R1	R0	G5	G4	G3	G2	G1	G0	B5	B4	B3	B2	B1	B0
Basic Colors	Black	0	0	0	0	0	0	0	0	0	0	0	0	0	0	0	0	0	0
	Red	1	1	1	1	1	1	0	0	0	0	0	0	0	0	0	0	0	0
	Green	0	0	0	0	0	0	1	1	1	1	1	1	0	0	0	0	0	0
	Blue	0	0	0	0	0	0	0	0	0	0	0	0	1	1	1	1	1	1
	Cyan	0	0	0	0	0	0	1	1	1	1	1	1	1	1	1	1	1	1
	Magenta	1	1	1	1	1	1	0	0	0	0	0	0	1	1	1	1	1	1
	Yellow	1	1	1	1	1	1	1	1	1	1	1	1	0	0	0	0	0	0
	White	1	1	1	1	1	1	1	1	1	1	1	1	1	1	1	1	1	1
Gray Scale of Red	Red(0) / Dark	0	0	0	0	0	0	0	0	0	0	0	0	0	0	0	0	0	0
	Red(1)	0	0	0	0	0	1	0	0	0	0	0	0	0	0	0	0	0	0
	Red(2)	0	0	0	0	1	0	0	0	0	0	0	0	0	0	0	0	0	0
	:	:	:	:	:	:	:	:	:	:	:	:	:	:	:	:	:	:	:
	:	:	:	:	:	:	:	:	:	:	:	:	:	:	:	:	:	:	:
	Red(61)	1	1	1	1	0	1	0	0	0	0	0	0	0	0	0	0	0	0
	Red(62)	1	1	1	1	1	0	0	0	0	0	0	0	0	0	0	0	0	0
	Red(63)	1	1	1	1	1	1	0	0	0	0	0	0	0	0	0	0	0	0
Gray Scale of Green	Green(0)/ Dark	0	0	0	0	0	0	0	0	0	0	0	0	0	0	0	0	0	0
	Green(1)	0	0	0	0	0	0	0	0	0	0	0	1	0	0	0	0	0	0
	Green(2)	0	0	0	0	0	0	0	0	0	0	1	0	0	0	0	0	0	0
	:	:	:	:	:	:	:	:	:	:	:	:	:	:	:	:	:	:	:
	:	:	:	:	:	:	:	:	:	:	:	:	:	:	:	:	:	:	:
	Green(61)	0	0	0	0	0	0	1	1	1	1	0	1	0	0	0	0	0	0
	Green(62)	0	0	0	0	0	0	1	1	1	1	1	0	0	0	0	0	0	0
	Green(63)	0	0	0	0	0	0	1	1	1	1	1	1	0	0	0	0	0	0
Gray Scale of Blue	Blue(0)/ Dark	0	0	0	0	0	0	0	0	0	0	0	0	0	0	0	0	0	0
	Blue (1)	0	0	0	0	0	0	0	0	0	0	0	0	0	0	0	0	0	1
	Blue (2)	0	0	0	0	0	0	0	0	0	0	0	0	0	0	0	0	1	0
	:	:	:	:	:	:	:	:	:	:	:	:	:	:	:	:	:	:	:
	:	:	:	:	:	:	:	:	:	:	:	:	:	:	:	:	:	:	:
	Blue (61)	0	0	0	0	0	0	0	0	0	0	0	0	1	1	1	1	0	1
	Blue (62)	0	0	0	0	0	0	0	0	0	0	0	0	1	1	1	1	1	0
	Blue (63)	0	0	0	0	0	0	0	0	0	0	0	0	1	1	1	1	1	1

### Correspondence between Data and Display Position

	S0001	S0002	S0003	S0004	S0005	S0006	S0007	S0008	-----	S2399	S2400
C001	R001	G001	B001	R002	G002	B002	R003	G003		G800	B800
...											
C480	R001	G001	B001	R002	G002	B002	R003	G003		G800	B800

### 8. OPTICAL CHARACTERISTIC

Parameter		Symbol	Condition	MIN.	TYP.	MAX.	Unit	Remarks
Viewing Angle	Horizontal	$\theta_{x+}$	Center CR $\geq$ 10	65	70	--	deg	Note 1,4
		$\theta_{x-}$		65	70	--		
	Vertical	$\theta_{y+}$		55	60	--		
		$\theta_{y-}$		55	60	--		
Contrast Ratio		CR	at optimized viewing angle	250	400	--		Note 1,3
Response time	Rise	Tr	Center	-	5	10	ms	Note 1,6
	Fall	Tf	$\theta_x=\theta_y=0^\circ$	-	11	16	ms	
Uniformity		B-uni	$\theta_x=\theta_y=0^\circ$	70	80	--	%	Note1,5
Brightness		L	$\theta_x=\theta_y=0^\circ$	320	400	--	cd/m <sup>2</sup>	Note 1,2
Chromaticity		$x_W$	Center $\theta_x=\theta_y=0^\circ$	0.26	0.31	0.36		Note 1,7
		$y_W$		0.28	0.33	0.38		
		$x_R$		TBD	TBD	TBD		
		$y_R$		TBD	TBD	TBD		
		$x_G$		TBD	TBD	TBD		
		$y_G$		TBD	TBD	TBD		
		$x_B$		TBD	TBD	TBD		
		$y_B$		TBD	TBD	TBD		
Image sticking		tis	2 hours			2	Sec	Note 8

The following optical specifications shall be measured in a darkroom or equivalent state (ambient luminance  $\leq$ 1 lux, and at room temperature). The operation temperature is 25°C $\pm$ 2°C and LED Backlight Current IL=180mA. The measurement method is shown in Note1.

Note1: The method of optical measurement:

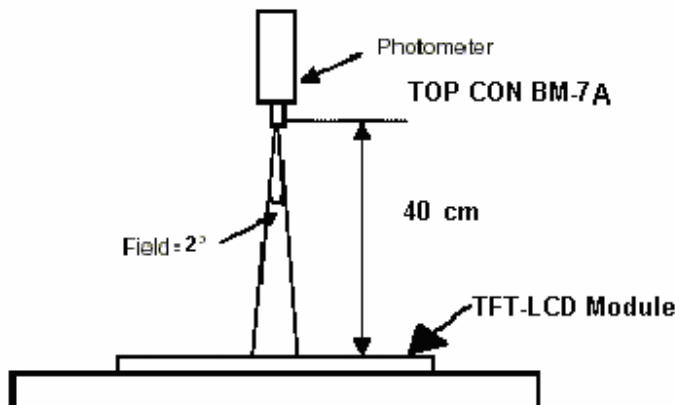

Note2: Measured at the center area of the panel and at the viewing angle of the  $\theta_x = \theta_y = 0^\circ$

Note3: Definition of Contrast Ratio (CR):

$$CR = \frac{\text{Luminance with all pixels in white state}}{\text{Luminance with all pixels in Black state}}$$

Note4: Definition of Viewing Angle

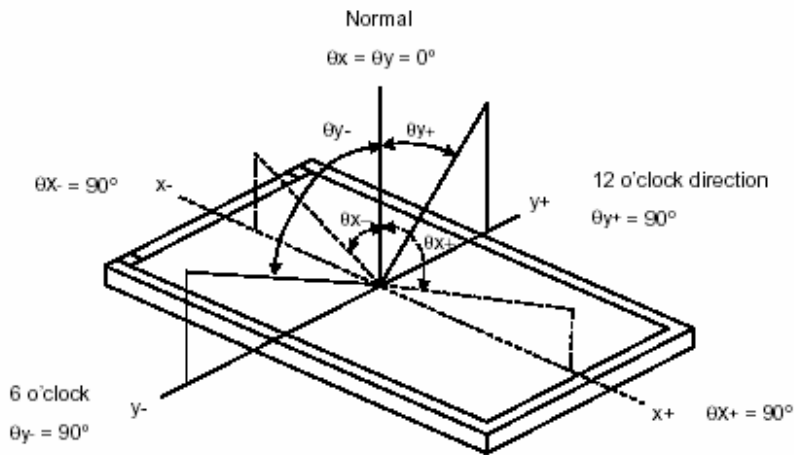

Note 5: Definition of Brightness Uniformity (B-uni):

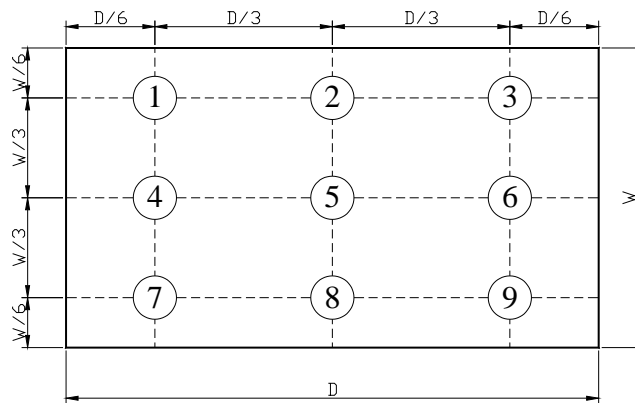

$$B\text{-uni} = \frac{\text{Minimum luminance of 9 points}}{\text{Maximum luminance of 9 points}} \quad (\text{Note 5}).$$



Note6: Definition of Response Time:

The Response Time is set initially by defining the “Rising Time (Tr)” and the “Falling Time (Tf)” respectively. Tr and Tf are defined as following figure.

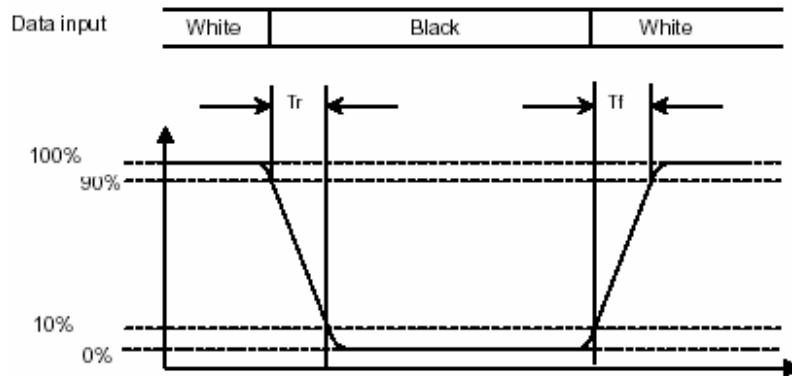

Note 7: Definition of Chromaticity:

The color coordinates  $(x_W, y_W)$ ,  $(x_R, y_R)$ ,  $(x_G, y_G)$ , and  $(x_B, y_B)$  are obtained with all pixels in the viewing field at white, red, green, and blue states, respectively.

Note 8: Definition of Image sticking (tis):

Continuously display the test pattern shown in the figure below for 2 hours. Then display a completely white screen. The previous image shall not persist more than 2 sec at 25 °C

**Image sticking pattern**

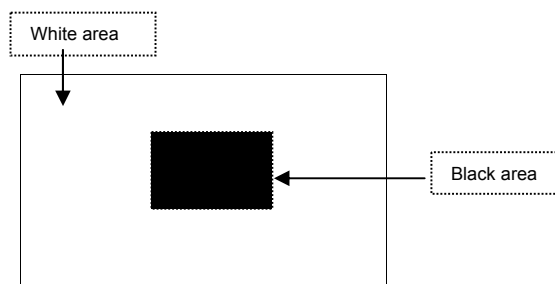

## 9. PIN CONNECTIONS

Pin NO.	SYMBOL	DESCRIPTION
1	V <sub>SS</sub>	Power Ground
2	V <sub>SS</sub>	Power Ground
3	ADJ	Brightness control for LED B/L
4	VDD	Power Supply for LED Driver
5	VDD	Power Supply for LED Driver
6	VDD	Power Supply for LED Driver
7	V <sub>CC</sub>	Power Supply for Digital Circuit
8	V <sub>CC</sub>	Power Supply for Digital Circuit
9	DE	Data Enable
10	V <sub>SS</sub>	Power Ground
11	V <sub>SS</sub>	Power Ground
12	V <sub>SS</sub>	Power Ground
13	B5	Blue Data 5 (MSB)
14	B4	Blue Data 4
15	B3	Blue Data 3
16	V <sub>SS</sub>	Power Ground
17	B2	Blue Data 2
18	B1	Blue Data 1
19	B0	Blue Data 0 (LSB)
20	V <sub>SS</sub>	Power Ground
21	G5	Green Data 5 (MSB)
22	G4	Green Data 4
23	G3	Green Data 3
24	V <sub>SS</sub>	Power Ground
25	G2	Green Data 2
26	G1	Green Data 1
27	G0	Green Data 0 (LSB)
28	V <sub>SS</sub>	Power Ground
29	R5	Red Data 5 (MSB)
30	R4	Red Data 4
31	R3	Red Data 3
32	V <sub>SS</sub>	Power Ground
33	R2	Red Data 2
34	R1	Red Data 1
35	R0	Red Data 0
36	V <sub>SS</sub>	Power Ground
37	V <sub>SS</sub>	Power Ground
38	DCLK	Clock Signals ; Latch Data at the Falling Edge
39	V <sub>SS</sub>	Power Ground
40	V <sub>SS</sub>	Power Ground

Remarks :

- 1) ADJ is brightness control Pin. The larger of the pulse duty is the higher of the brightness.
- 2) ADJ signal is 0~3.3V. Operation frequency is 20KHz
- 3) VSS PIN must be grounding, can not be floating.

Remarks:

Power Signal sequence:

$t1 \leq 10\text{ms}$  ;  $1 \text{ sec} \leq t5$

$50\text{ms} \leq t2$  ;  $200\text{ms} \leq t6$

$0 < t3 \leq 50\text{ms}$  ;  $200\text{ms} \leq t7$

$0 < t4 \leq 10\text{ms}$

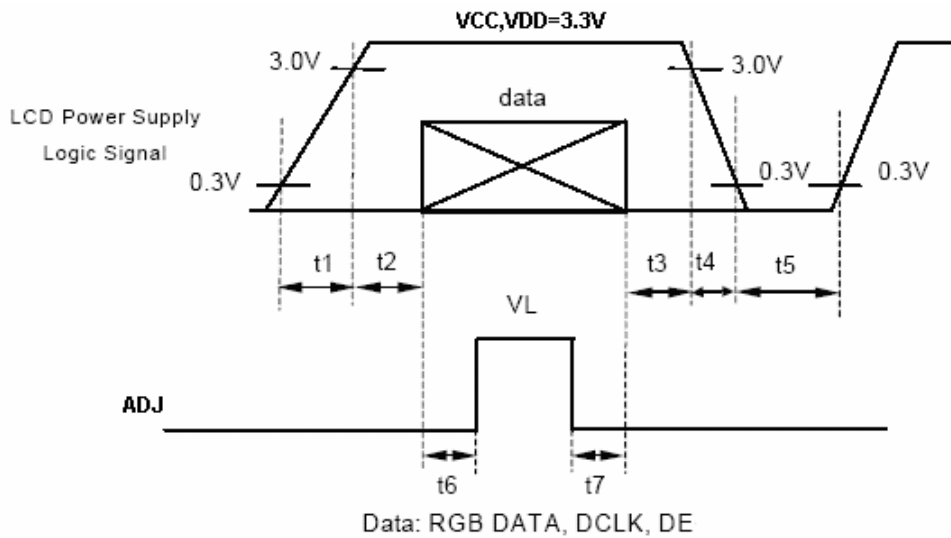

VCC,VDD -dip condition:

(1)  $2.7\text{V} \leq VCC, VDD \leq 3.0\text{V}$ :  $t_d \leq 10 \text{ ms}$

(2)  $VCC, VDD > 3.0\text{V}$ : VCC,VDD -dip condition should be the same with VCC,VDD-turn-on condition.

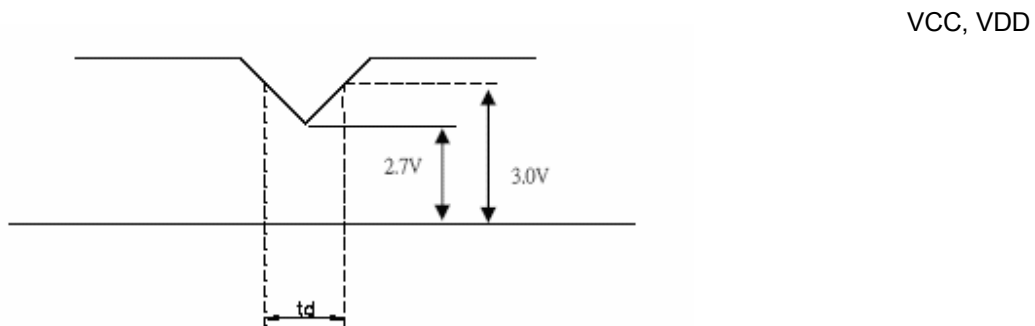

**10. BLOCK DIAGRAM**

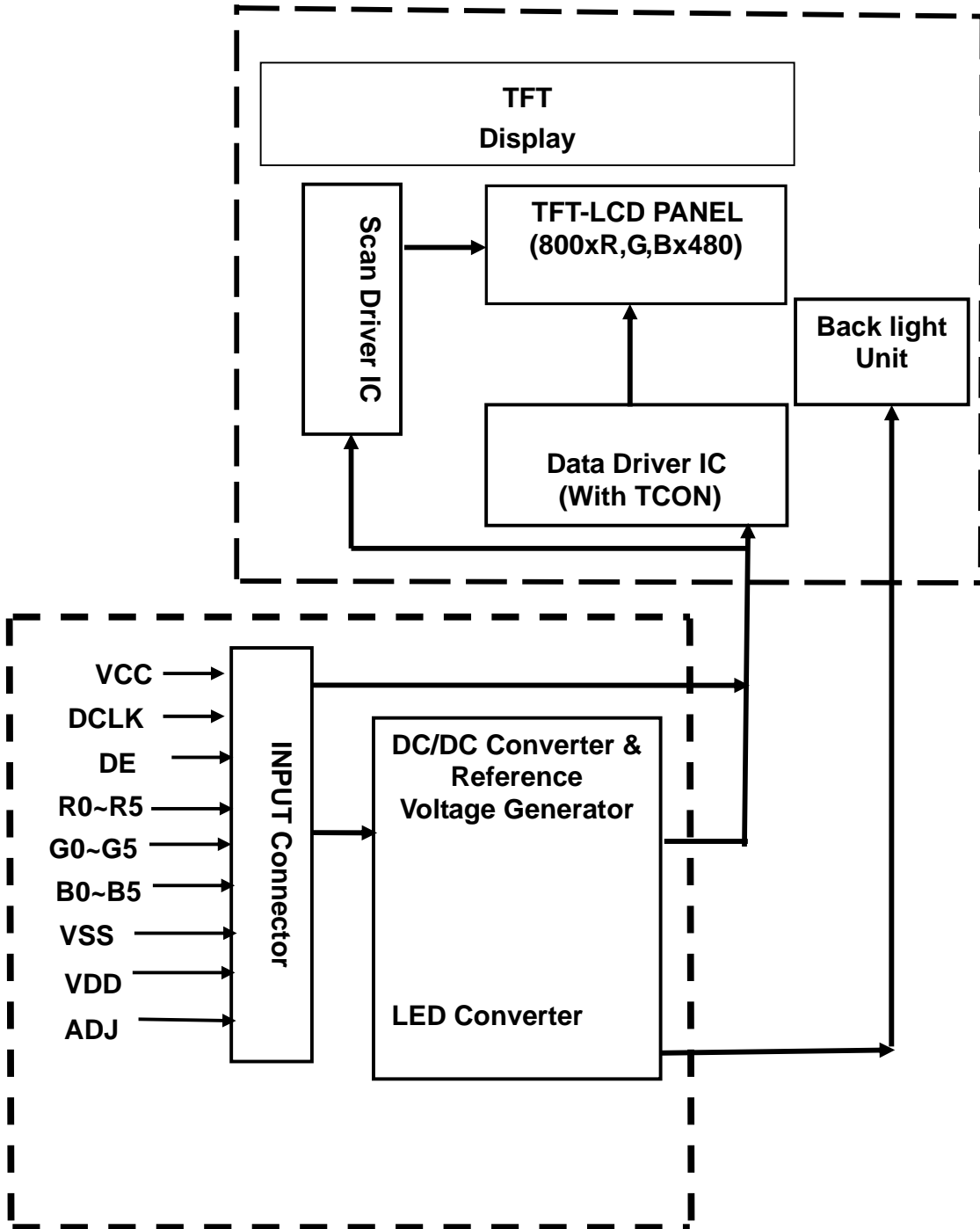

## 11. QUALITY ASSURANCE

### 11.1 Test Condition

#### 11.1.1 Temperature and Humidity(Ambient Temperature)

Temperature :  $25 \pm 5^{\circ}\text{C}$

Humidity :  $65 \pm 5\%$

#### 11.1.2 Operation

Unless specified otherwise, test will be conducted under function state.

#### 11.1.3 Container

Unless specified otherwise, vibration test will be conducted to the product itself without putting it in a container.

#### 11.1.4 Test Frequency

In case of related to deterioration such as shock test. It will be conducted only once.

#### 11.1.5 Test Method

Reliability Test Item & Level		
No.	Test Item	Test Level
1	High Temperature Storage Test	T=80 ,240hrs
2	Low Temperature Storage Test	T=-30 ,240hrs
3	High Temperature Operation Test	T=70 ,240hrs
4	Low Temperature Operation Test	T=-20 ,240hrs
5	High Temperature and High Humidity (No operation)	T=60 ,90%RH,240hrs
6	Thermal Cycling Test (No operation)	-30 → +25 → +80 , 100 Cycles 30 min 5 min 30 min
7	Vibration Test (No operation)	Frequency :10 ~ 55 Hz Amplitude :1.5 mm Sweep time : 11 mins Test Period: 6 Cycles for each direction of X, Y, Z

### 11.2 Judgment standard

The Judgment of the above test should be made as follow:

Pass: Normal display image with no obvious non-uniformity and no line defect. Partial transformation of the module parts should be ignored.

Fail: No display image, obvious non-uniformity, or line defect.

## 12. LOT NUMBERING SYSTEM

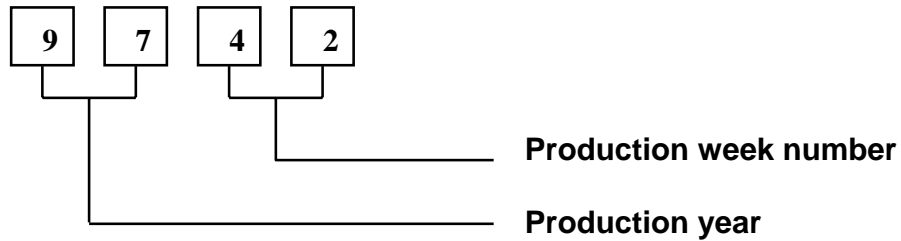

## 13. LCM NUMBERING SYSTEM

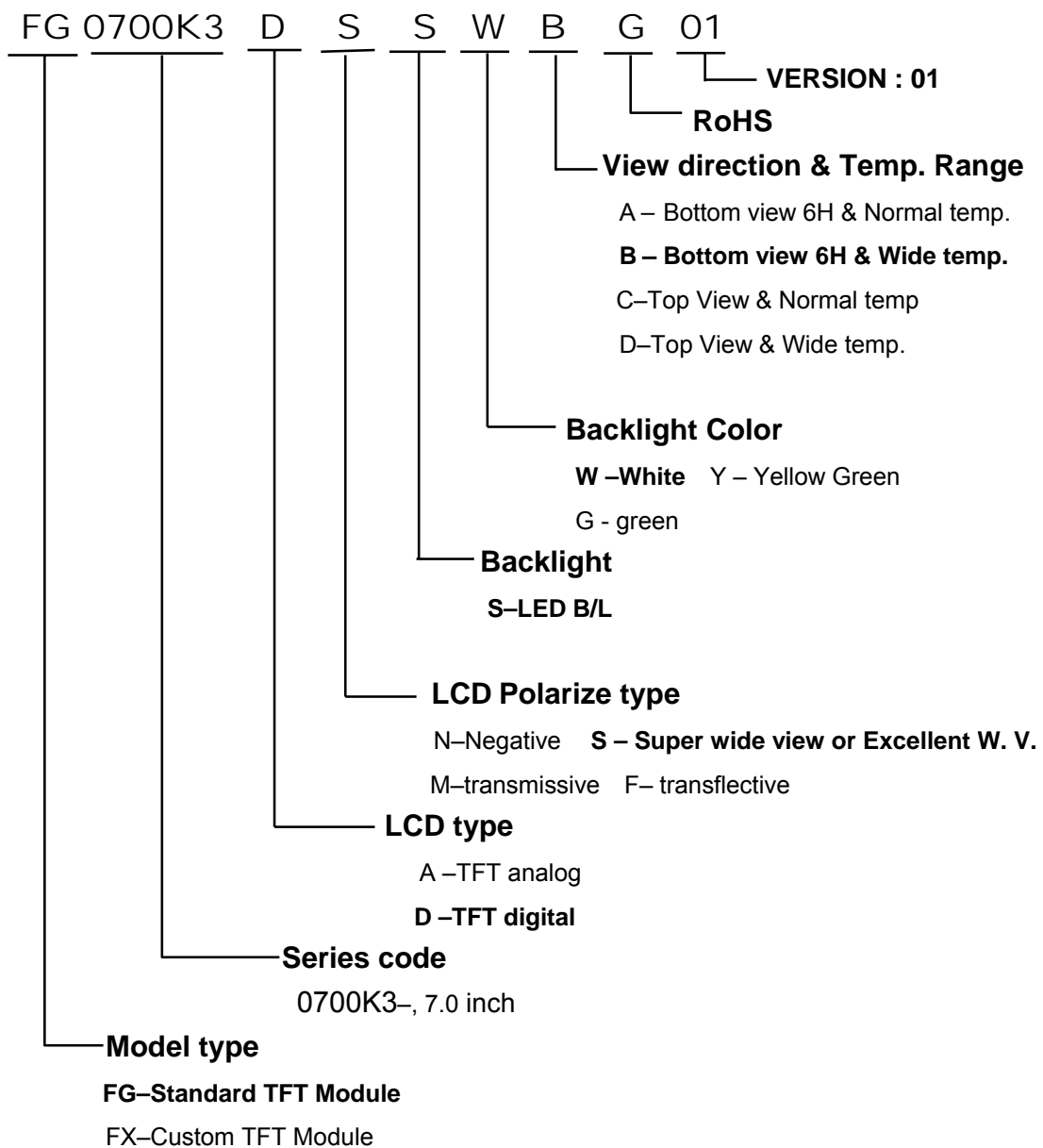

## 14. PRECAUTIONS IN USE LCM

### 1. LIQUID CRYSTAL DISPLAY (LCD)

LCD is made up of glass, organic sealant, organic fluid, and polymer based polarizers. The following precautions should be taken when handling,

- (1). Keep the temperature within range of use and storage. Excessive temperature and humidity could cause polarization degradation, polarizer peel off or bubble.
- (2). Do not contact the exposed polarizers with anything harder than an HB pencil lead. To clean dust off the display surface, wipe gently with cotton, chamois or other soft material soaked in petroleum benzine.
- (3). Wipe off saliva or water drops immediately. Contact with water over a long period of time may cause polarizer deformation or color fading, while an active LCD with water condensation on its surface will cause corrosion of ITO electrodes.
- (4). Glass can be easily chipped or cracked from rough handling, especially at corners and edges.
- (5). Do not drive LCD with DC voltage.

### 2. Liquid Crystal Display Modules

#### 2.1 Mechanical Considerations

LCM are assembled and adjusted with a high degree of precision. Avoid excessive shocks and do not make any alterations or modifications. The following should be noted.

- (1). Do not tamper in any way with the tabs on the metal frame.
- (2). Do not modify the PCB by drilling extra holes, changing its outline, moving its components or modifying its pattern.
- (3). Do not touch the elastomer connector, especially insert an backlight panel (for example, EL).
- (4). When mounting a LCM make sure that the PCB is not under any stress such as bending or twisting. Elastomer contacts are very delicate and missing pixels could result from slight dislocation of any of the elements.
- (5). Avoid pressing on the metal bezel, otherwise the elastomer connector could be deformed and lose contact, resulting in missing pixels.

#### 2.2. Static Electricity

LCM contains CMOS LSI's and the same precaution for such devices should apply, namely

- (1). The operator should be grounded whenever he/she comes into contact with the module. Never touch any of the conductive parts such as the LSI pads, the copper leads on the PCB and the interface terminals with any parts of the human body.
- (2). The modules should be kept in antistatic bags or other containers resistant to static for storage.
- (3). Only properly grounded soldering irons should be used.
- (4). If an electric screwdriver is used, it should be well grounded and shielded from commutator sparks.

- (5) The normal static prevention measures should be observed for work clothes and working benches; for the latter conductive (rubber) mat is recommended.
- (6). Since dry air is inductive to statics, a relative humidity of 50-60% is recommended.

#### 2.3 Soldering

- (1). Solder only to the I/O terminals.
- (2). Use only soldering irons with proper grounding and no leakage.
- (3). Soldering temperature :  $280^{\circ}\text{C} \pm 10^{\circ}\text{C}$
- (4). Soldering time: 3 to 4 sec.
- (5). Use eutectic solder with resin flux fill.
- (6). If flux is used, the LCD surface should be covered to avoid flux spatters. Flux residue should be removed afterwards.

#### 2.4 Operation

- (1). The viewing angle can be adjusted by varying the LCD driving voltage  $V_0$ .
- (2). Driving voltage should be kept within specified range; excess voltage shortens display life.
- (3). Response time increases with decrease in temperature.
- (4). Display may turn black or dark blue at temperatures above its operational range; this is (however not pressing on the viewing area) may cause the segments to appear "fractured".
- (5). Mechanical disturbance during operation (such as pressing on the viewing area) may cause the segments to appear "fractured".

#### 2.5 Storage

If any fluid leaks out of a damaged glass cell, wash off any human part that comes into contact with soap and water. Never swallow the fluid. The toxicity is extremely low but caution should be exercised at all the time.

#### 2.6 Limited Warranty

Unless otherwise agreed between DATA IMAGE and customer, DATA IMAGE will replace or repair any of its LCD and LCM which is found to be defective electrically and visually when inspected in accordance with DATA IMAGE acceptance standards, for a period on one year from date of shipment. Confirmation of such date shall be based on freight documents. The warranty liability of DATA IMAGE is limited to repair and/or replacement on the terms set forth above. DATA IMAGE will not responsible for any subsequent or consequential events.

Confidential Document  
**15. OUTLINE DRAWING**

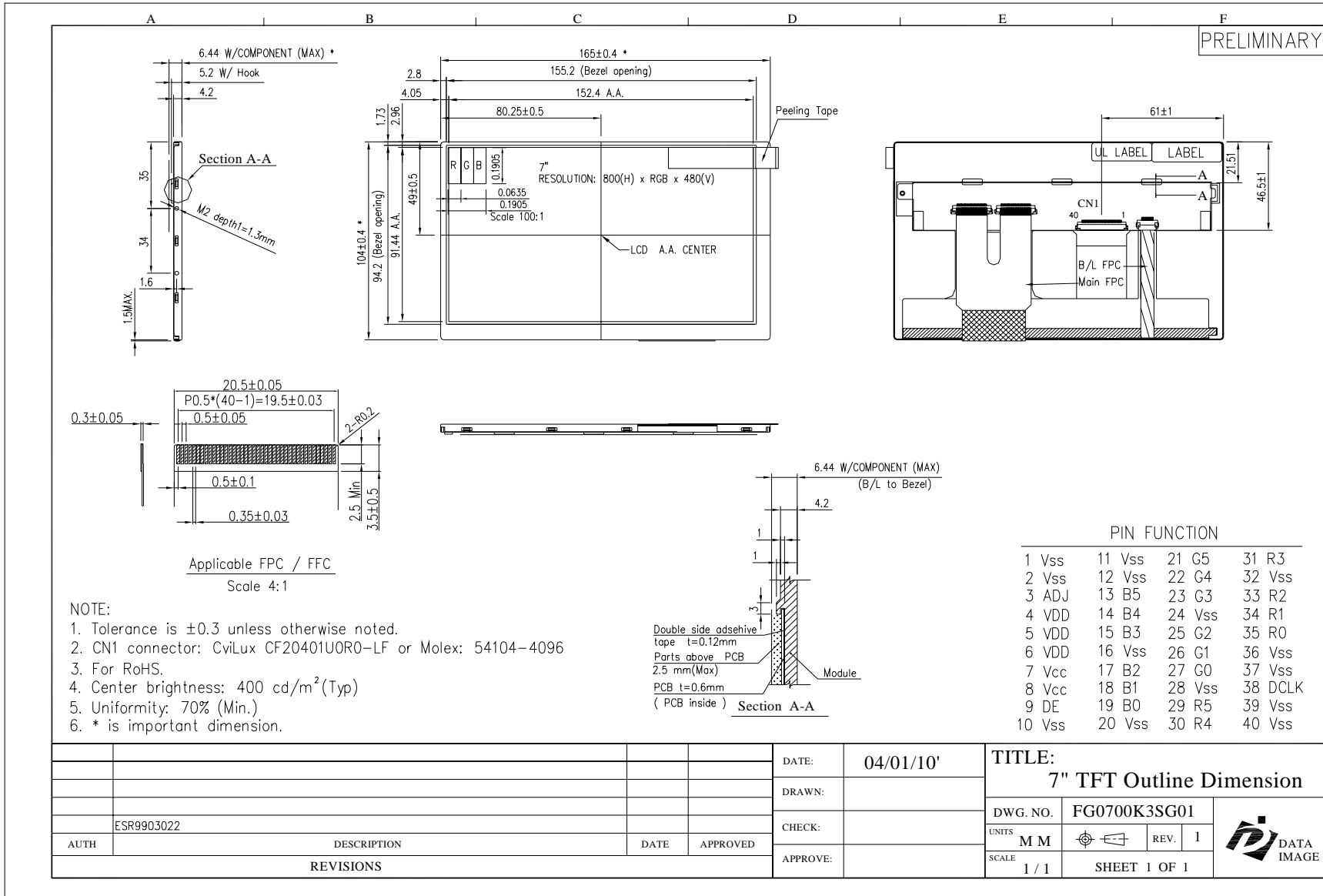



**16. PACKAGE INFORMATION**

TBD