



DATA IMAGE CORPORATION

TFT Module Specification PRELIMINARY

ITEM NO.: FG080016DNCWAGL1

Table of Contents

- 1. COVER & CONTENTS 1
- 2. RECORD OF REVISION 2
- 3. GENERAL SPECIFICATIONS 3
- 4. ABSOLUTE MAXIMUM RATINGS 3
- 5. ELECTRICAL CHARACTERISTICS 3
- 6. INTERFACE SPECIFICATIONS 5
- 7. OPTICAL CHARACTERISTIC 8
- 8. PIN CONNECTIONS 11
- 9. BLOCK DIAGRAM 13
- 10. QUALITY ASSURANCE 14
- 11. LOT NUMBERING SYSTEM 15
- 12. LCM NUMBERING SYSTEM 16
- 13. PRECAUTIONS IN USE LCM 16
- 14. OUTLINE DRAWING 17
- 15. PACKAGE INFORMATION 18

Customer Companies	R&D Dept.	Q.C. Dept.	Eng. Dept.	Prod. Dept.
	ALEX	ERIC	GARY	HUANG
Approved by	Version:	Issued Date:	Sheet Code:	Total Pages:
	1	2007/2/13		18



2. RECORD OF REVISION

Rev	Date	Item	Page	Comment
1	13/FEB/07			Initial PRELIMINARY

3. GENERAL SPECIFICATIONS

Parameter	Specifications	Unit
Screen Size	8 (diagonal)	inch
Display Format	640(H) x (R,G,B) x 480(V)	dot
Active Area	162.2(H) x 121.7 (V)	mm
Dot Pitch	0.2535 (H) x 0.2535 (V)	mm
Pixel Configuration	Stripe	
Outline Dimension	183.0(W) x 141.0(H) x 14 (D)	mm
Surface treatment	Anti-glare and hard coating	
Back-light	CCFL	
Display mode	Normally white	
Weight	360	g
View Angle direction	6 o'clock	
Our components and processes are compliant to RoHS standard		

4. ABSOLUTE MAXIMUM RATINGS:

Parameter	Symbol	MIN.	MAX.	Unit	Remark
Power supply voltage	V _{CC}	2.5	3.6	V	Ta=25°C
Logic input voltage	V _I	-0.3	V _{CC} +0.3	V	
Operating temperature	T _{OP}	0	+55	°C	Module surface*
Storage temperature	T _{ST}	-25	+70	°C	-
Humidity	Operation	20%~80% relative humidity			Ta<=40°C
	Non Operation	5%~80% relative humidity			Ta<=40°C

*Module at the active display area.

5. ELECTRICAL CHARACTERISTICS

A) Module

Ta=25°C,CK=25MHz

Parameter	Symbol	MIN.	Typ.	MAX.	Unit	Remark
Power Supply voltage	V _{CC}	3.0	3.3	3.6	V	
Power Supply Current	I _{CC}	--	135	200	mA	V _{CC} =3.3V
Ripple voltage	V _{RF}	-	-	100	mV _{P-P}	
"H" level logical input voltage	V _{IH}	0.7V _{CC}	-	V _{CC} +0.3	V	
"L" level logical input voltage	V _{IL}	-0.3	-	0.8	V	

B).Backlight

Ta=25 ±2°C

Parameter	Symbol	MIN.	Typ.	MAX.	Unit	Remark
Lamp Voltage	V_L		910	--	Vrms	IL=6.0mA
Lamp Current	I_L	5.0	6.0	7.0	mArms	Note 2
Lamp frequency		40	50	60	KHZ	
Startup Voltage	V_s			1500	Vrms	(25°C) Note 3
				2000	Vrms	(0°C) Note 3

Note 1:Operating Temp. range:0~55°C

Note 2:Lamp current is measured by utilizing a current meter for high frequency as shown below:

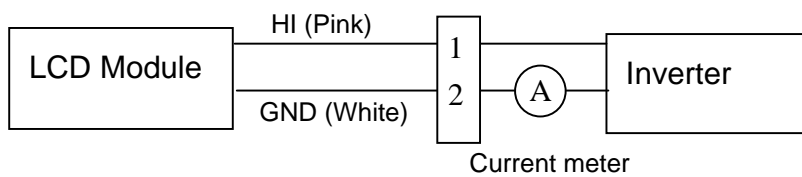

Note 3:The voltage shown above should be applied to the lamp for more than 2 second after startup. Other wise the lamp may not be turned on.

Note 4:The lamp frequency may produce interference with horizontal synchronous frequency from the display, and this may cause line flow on the display. In order to avoid interference the lamp frequency should be detached from the horizontal synchronous frequency and its harmonics as far as possible.

Note 5: $P_L = I_L \times V_L$.

Note 6:The lifetime(Hr) of a lamp can be defined as the time in which it continues to operate under the condition Ta=25±2 and IL=6.0 mArms until one of the following event occurs:

(1)When the brightness becomes or lower than 50% its original value.

(2)When the effective ignition length becomes or lower than 80% its original value.(Effective ignition length is defined as an area that has less than 70% brightness compared to the brightness in the center point.)

Note 7:The waveform of the voltage output of inverter must be area-symmetric and the design of the inverter must have specifications for the modularized lamp. The performance of the backlight, such as lifetime or brightness, is greatly influenced by the characteristics of the DC-AC inverter for the lamp. All the parameters of an inverter should be designed with care so as not to produce too much current leakage from high-voltage output of the inverter. When designing or ordering the inverter, please make sure that a poor lighting caused by the mismatch of the backlight and the inverter (miss-lighting, flicker, etc.) never occurs. When the above situation is confirmed, the module should be operated in the same manners as it is installed in your instrument.

6. INTERFACE SPECIFICATIONS

6.1 INPUT SIGNAL TIMING SPECIFICATIONS

Signal	Parameter	Symbol	MIN.	TYP.	MAX.	Unit	Remarks
CK	Period	t_{CLK}	42	40	31	ns	
	Frequency	f_{CLK}	24	25	32.5	MHz	
	Low Level Width	t_{WCL}	6	-	-	ns	
	High Level Width	t_{WCH}	6	-	-	ns	
	Rise, Fall Time	t_{CLKr}, t_{CLKf}	-	-	3	ns	
	Duty ⁽¹⁾	-	0.45	0.50	0.55	-	
ENAB (Data Enable)	Setup Time	t_{DES}	5	-	-	ns	
	Hold Time	t_{DEH}	10	-	-	ns	
	Rise, Fall Time	t_{DEr}, t_{DEf}	-	-	16	ns	
	Horizontal Period	t_{HP}	788	800	890	t_{CLK}	
	Horizontal Valid	t_{HV}	640	640	640	t_{CLK}	
	Horizontal Blank	t_{HBK}	148	160	250	t_{CLK}	
	Vertical Period	t_{VP}	516	525	561	t_{HP}	
	Vertical Valid	t_{VW}	480	480	480	t_{HP}	
	Vertical Blank	t_{VBK}	36	45	81	t_{HP}	
	Vertical Frequency	f_v	50	60	80	Hz	
Data R,G,B	Setup Time	t_{DS}	5	-	-	ns	
	Hold Time	t_{DH}	10	-	-	ns	
	Rise, Fall Time	t_{Dr}, t_{Df}	-	-	3	ns	

Note: (1) t_{CLKL} / t_{CLK} .

6.1.1 DE AND RGB INPUT DATA TIMING WAVEFORM

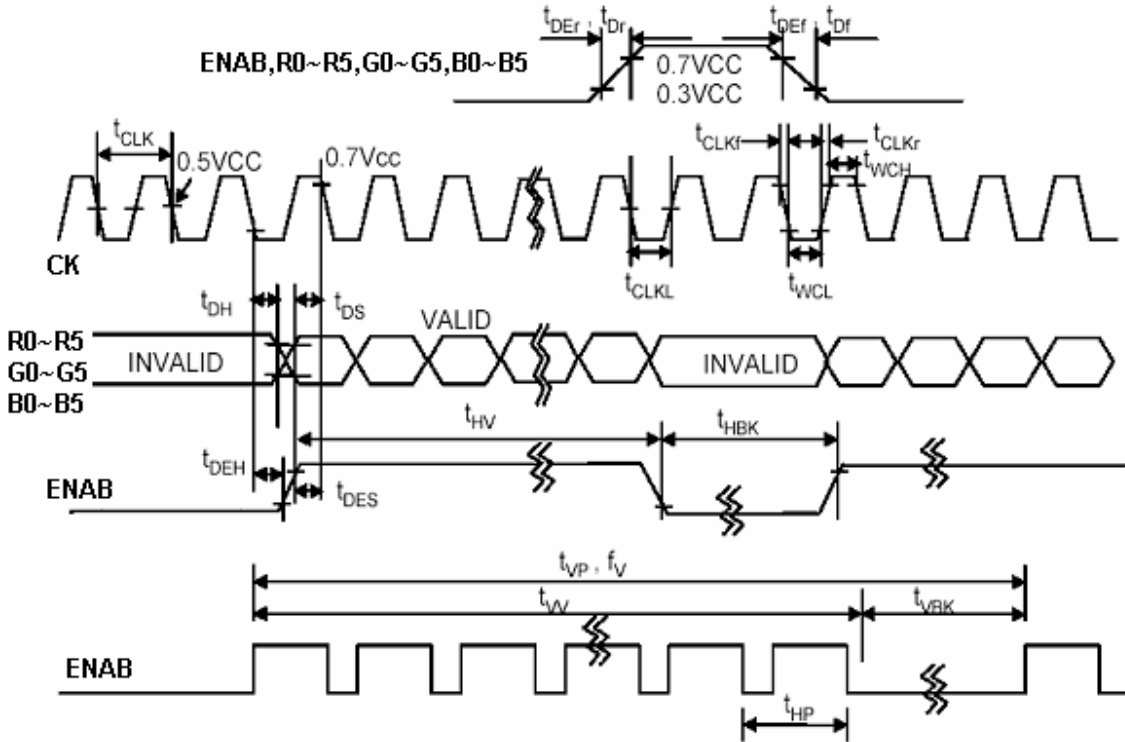

6.2 COLOR DATA INPUT ASSIGNMENT

		Data Signal																	
		Red						Green						Blue					
Color		R5	R4	R3	R2	R1	R0	G5	G4	G3	G2	G1	G0	B5	B4	B3	B2	B1	B0
Basic Colors	Black	0	0	0	0	0	0	0	0	0	0	0	0	0	0	0	0	0	0
	Red	1	1	1	1	1	1	0	0	0	0	0	0	0	0	0	0	0	0
	Green	0	0	0	0	0	0	1	1	1	1	1	1	0	0	0	0	0	0
	Blue	0	0	0	0	0	0	0	0	0	0	0	0	1	1	1	1	1	1
	Cyan	0	0	0	0	0	0	1	1	1	1	1	1	1	1	1	1	1	1
	Magenta	1	1	1	1	1	1	0	0	0	0	0	0	1	1	1	1	1	1
	Yellow	1	1	1	1	1	1	1	1	1	1	1	1	0	0	0	0	0	0
	White	1	1	1	1	1	1	1	1	1	1	1	1	1	1	1	1	1	1
Gray Scale of Red	Red(0) / Dark	0	0	0	0	0	0	0	0	0	0	0	0	0	0	0	0	0	0
	Red(1)	0	0	0	0	0	1	0	0	0	0	0	0	0	0	0	0	0	0
	Red(2)	0	0	0	0	1	0	0	0	0	0	0	0	0	0	0	0	0	0
	:	:	:	:	:	:	:	:	:	:	:	:	:	:	:	:	:	:	:
	:	:	:	:	:	:	:	:	:	:	:	:	:	:	:	:	:	:	:
	Red(61)	1	1	1	1	0	1	0	0	0	0	0	0	0	0	0	0	0	0
	Red(62)	1	1	1	1	1	0	0	0	0	0	0	0	0	0	0	0	0	0
	Red(63)	1	1	1	1	1	1	0	0	0	0	0	0	0	0	0	0	0	0
Gray Scale of Green	Green(0)/ Dark	0	0	0	0	0	0	0	0	0	0	0	0	0	0	0	0	0	0
	Green(1)	0	0	0	0	0	0	0	0	0	0	0	1	0	0	0	0	0	0
	Green(2)	0	0	0	0	0	0	0	0	0	0	1	0	0	0	0	0	0	0
	:	:	:	:	:	:	:	:	:	:	:	:	:	:	:	:	:	:	:
	:	:	:	:	:	:	:	:	:	:	:	:	:	:	:	:	:	:	:
	Green(61)	0	0	0	0	0	0	1	1	1	1	0	1	0	0	0	0	0	0
	Green(62)	0	0	0	0	0	0	1	1	1	1	1	0	0	0	0	0	0	0
	Green(63)	0	0	0	0	0	0	1	1	1	1	1	1	0	0	0	0	0	0
Gray Scale of Blue	Blue(0)/ Dark	0	0	0	0	0	0	0	0	0	0	0	0	0	0	0	0	0	0
	Blue (1)	0	0	0	0	0	0	0	0	0	0	0	0	0	0	0	0	0	1
	Blue (2)	0	0	0	0	0	0	0	0	0	0	0	0	0	0	0	0	1	0
	:	:	:	:	:	:	:	:	:	:	:	:	:	:	:	:	:	:	:
	:	:	:	:	:	:	:	:	:	:	:	:	:	:	:	:	:	:	:
	Blue (61)	0	0	0	0	0	0	0	0	0	0	0	0	1	1	1	1	0	1
	Blue (62)	0	0	0	0	0	0	0	0	0	0	0	0	1	1	1	1	1	0
	Blue (63)	0	0	0	0	0	0	0	0	0	0	0	0	1	1	1	1	1	1

Correspondence between Data and Display Position

	S0001	S0002	S0003	S0004	S0005	S0006	S0007	S0008	-----	S1919	S1920
C001	R001	G001	B001	R002	G002	B002	R003	G003		G640	B640
C480	R001	G001	B001	R002	G002	B002	R003	G003		G640	B640

7. OPTICAL CHARACTERISTIC

7-1. SPECIFICATIONS:

Parameter		Symbol	Condition	MIN.	TYP.	MAX.	Unit	Remarks
Viewing Angle	Horizontal	θ_{x+}	Center CR \geq 5	60	65	--	deg	Note 1,3,4
		θ_{x-}		60	65	--		
	Vertical	θ_{y+}		50	55	--		
		θ_{y-}		60	65	--		
Contrast Ratio		CR max.	Center	100	250			Note 1,3
Response time	Rise	Tr	Center	-	15	30	ms	Note 1,6
	Fall	Tf	$\theta_x=\theta_y=0^\circ$	-	35	50	ms	
Brightness Uniformity		B-uni	$\theta_x=\theta_y=0^\circ$	70	80	--	%	Note1,5
Central Luminance		L	IL=6.0mA	320	400	--	cd/m ²	Note 1,2,4
Lamp Life time		--		10,000	50000	--	hours	
Chromaticity	X_W	Center $\theta_x=\theta_y=0^\circ$		0.256	0.306	0.356		Note 1,7
	Y_W			0.293	0.343	0.393		
	X_R			0.541	0.591	0.641		
	Y_R			0.291	0.341	0.391		
	X_G			0.257	0.307	0.357		
	Y_G			0.543	0.593	0.643		
	X_B			0.097	0.147	0.197		
	Y_B			0.075	0.125	0.175		
Image sticking		tis	2 hours			2	Sec	Note 8

The following optical specifications shall be measured in a darkroom or equivalent state (ambient luminance ≤ 1 lux, and at room temperature). The measurement must be taken after backlight warming up for 20 minutes. The operation temperature is $25^\circ\text{C} \pm 2^\circ\text{C}$. The measurement method is shown in Note1.

Note1: The method of optical measurement:

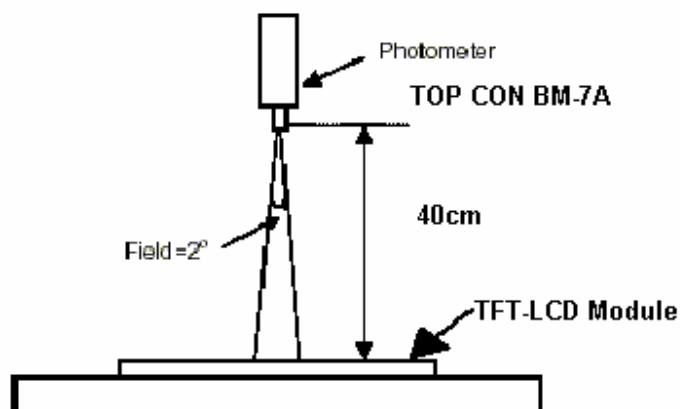

Note2: Definition of Central Luminance(L):

Central Luminance must be measured at the central point of the LCD module and at the viewing angle of the $\theta_x=\theta_y=0^\circ$ (Note 4) when all the input terminals of LCD panel are electrically opened.

Note3: Definition of Contrast Ratio (CR):

$$CR = \frac{\text{Luminance with all pixels in white state}}{\text{Luminance with all pixels in Black state}}$$

Note 4: Definition of Viewing Angle(CR \geq 5):

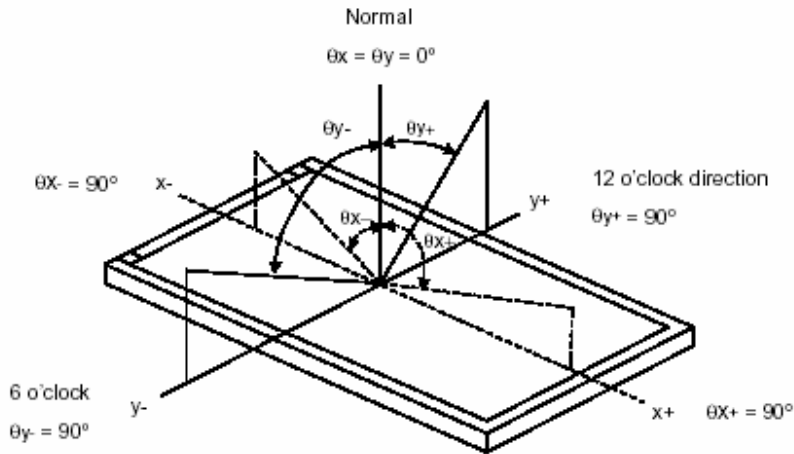

Note 5: Definition of Brightness Uniformity (Buni):

Luminance Measuring Points

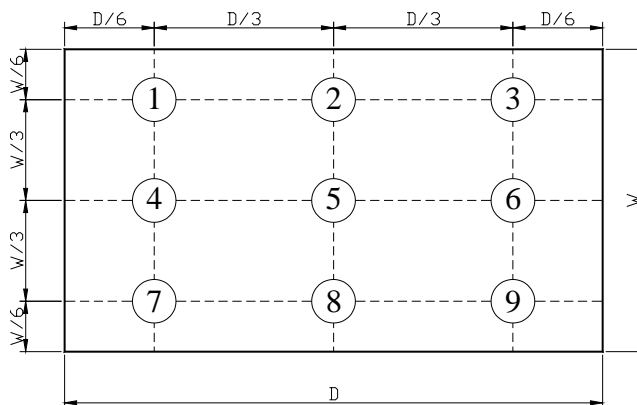

$$B\text{-uni} = \frac{\text{Minimum luminance of 9 points}}{\text{Maximum luminance of 9points}}$$

Note6: Definition of Response Time:

The Response Time is set initially by defining the "Rising Time (T_r)" and the "Falling Time (T_f)" respectively. T_r and T_f are defined as following figure.

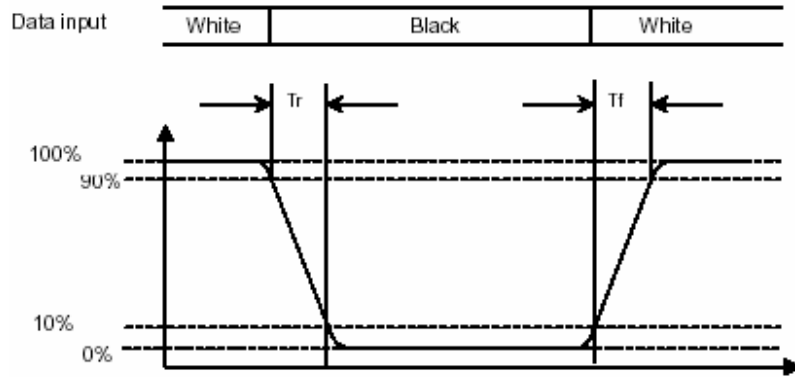

Note 7: Definition of Chromaticity:

The color coordinates (X_w, Y_w) , (X_r, Y_r) , (X_g, Y_g) , and (X_b, Y_b) are obtained with all pixels in the viewing field at white, red, green, and blue states, respectively.

Note 8: Definition of Image sticking (tis):

Continuously display the test pattern shown in the figure below for 2 hours. Then display a completely white screen. The previous image shall not persist more than 2 sec at 25 °C

Image sticking pattern

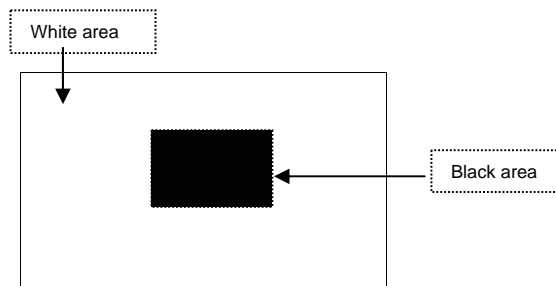

8. PIN CONNECTIONS

Pin No	Symbol	Function	Remark
1	GND	Ground for logic circuit	
2	CK	Data sampling clock	
3	HSYNC	Horizontal synchronous signal	
4	VSYNC	Vertical synchronous signal	
5	GND	Ground for logic circuit	
6	R0	Red pixel data(LSB)	
7	R1	Red pixel data	
8	R2	Red pixel data	
9	R3	Red pixel data	
10	R4	Red pixel data	
11	R5	Red pixel data(MSB)	
12	GND	Ground for logic circuit	
13	G0	Green pixel data(LSB)	
14	G1	Green pixel data	
15	G2	Green pixel data	
16	G3	Green pixel data	
17	G4	Green pixel data	
18	G5	Green pixel data(MSB)	
19	GND	Ground for logic circuit	
20	B0	Blue pixel data(LSB)	
21	B1	Blue pixel data	
22	B2	Blue pixel data	
23	B3	Blue pixel data	
24	B4	Blue pixel data	
25	B5	Blue pixel data(MSB)	
26	GND	Ground for logic circuit	
27	ENAB	Data enable signal	
28	Vcc	Power Supply : +3.3V	
29	Vcc	Power Supply : +3.3V	
30	R/L	Right/Left scan control input	
31	U/D	Up/Down scan control input	
32	GND	Ground for logic circuit	

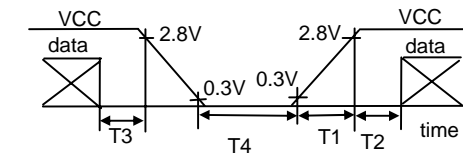
8.1 POWER OFF/ON SEQUENCE

Timing Specifications:

$0 < T1 \leq 15\text{ms}$

$0 < T2 \leq 20\text{ms}$

$0 < T3 \leq 1\text{s}$

$1\text{s} < T4$

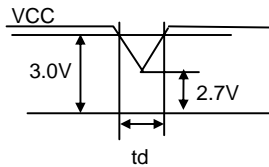

1) $2.7\text{V} \leq VCC < 3.0\text{V}$ $td \leq 10\text{ms}$

2) $VCC < 2.7\text{V}$

Notes: 1. Please avoid floating state of interface signal at invalid period.

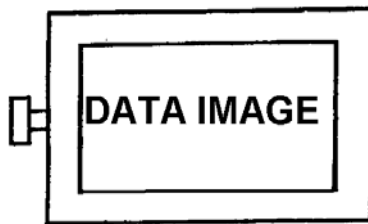
 2. When the interface signal is invalid, be sure to pull down the power supply for LCD V_{CC} to 0V.

(R/L=High, U/D=High)

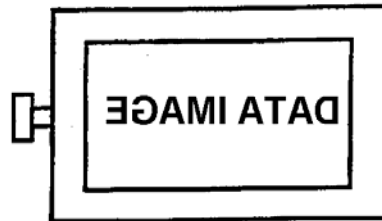

(R/L=Low, U/D=High)

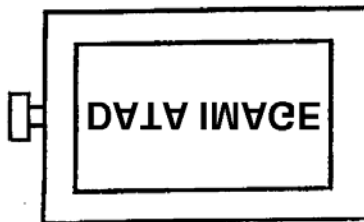

(R/L=High, U/D=Low)

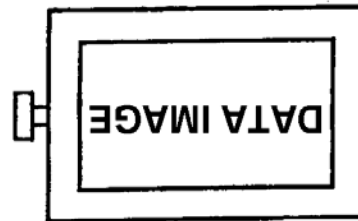

(R/L=Low, U/D=Low)

No.	Symbol	I/O	Description	Remark
1	HI	I	Power supply for backlight unit (High voltage)	
2	GND	-	Ground for backlight unit	

9. BLOCK DIAGRAM

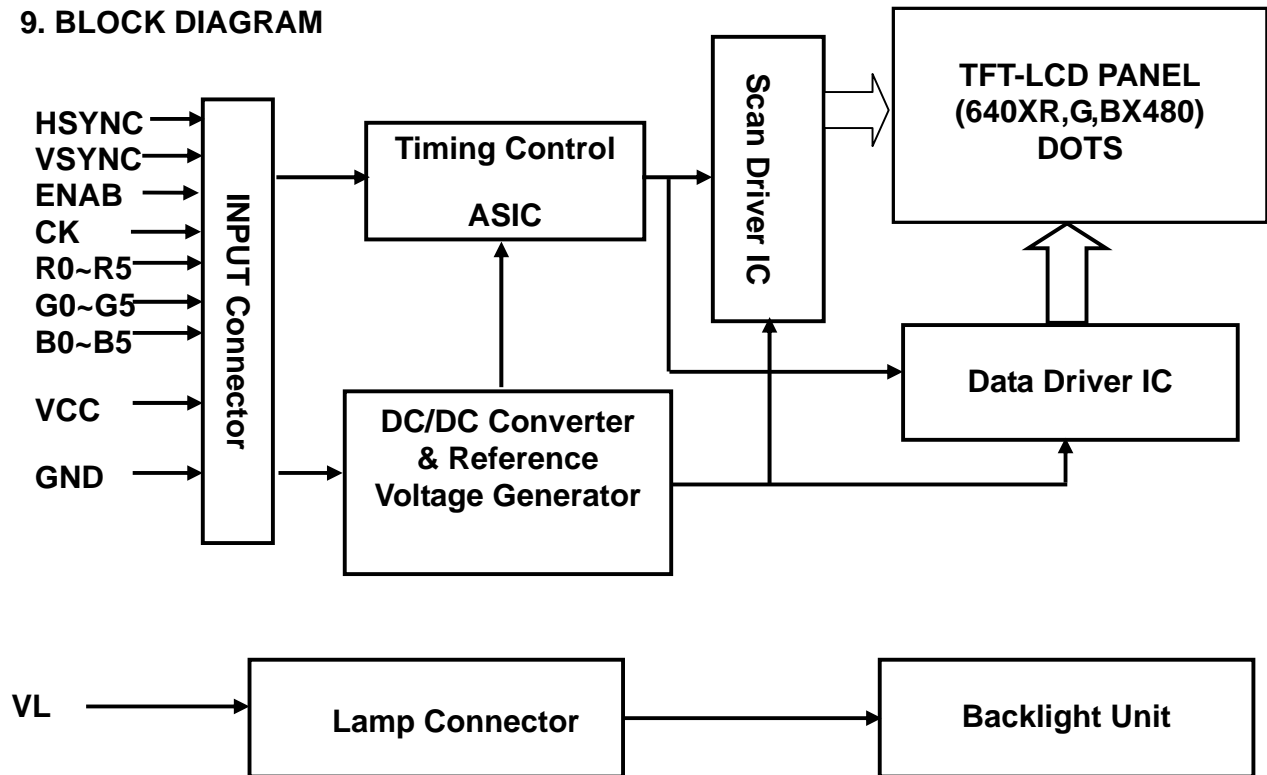

10. QUALITY ASSURANCE

10.1 TEST CONDITION

10.1.1 Temperature and Humidity(Ambient Temperature)

Temperature : $25 \pm 5^{\circ}\text{C}$

Humidity : $65 \pm 5\%$

10.1.2 Operation

Unless specified otherwise, test will be conducted under function state.

10.1.3 Container

Unless specified otherwise, vibration test will be conducted to the product itself without putting it in a container.

10.1.4 Test Frequency

In case of related to deterioration such as shock test. It will be conducted only once.

10.1.5 Test Method

Reliability Test Item & Level		Test Level
No.	Test Item	
1	High Temperature Storage Test	T=60°C,240hrs
2	Low Temperature Storage Test	T=-20°C,240hrs
3	High Temperature Operation Test	--
4	Low Temperature Operation Test	T=0°C,240hrs
5	High Temperature and High Humidity Operation Test	T=50°C,80%RH,240hrs
6	Thermal Cycling Test (No operation)	0°C → +25°C → +60°C,50 Cycles 60 min 30 min 60 min
7	Vibration Test (No operation)	Frequency : 10 ~ 57 Hz Amplitude : 1.0 mm 58 ~ 500 Hz, 1G Sweep Time : 11min Test Period : 3hrs (1hrs for each Direction of X,Y,Z)
8	Shock Test (No operation)	80G, 6ms Direction : ± X,± Y,± Z Cycle : 1 times

11. LOT NUMBERING SYSTEM

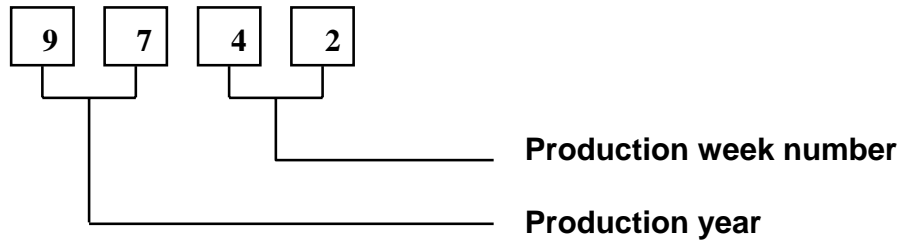

12. LCM NUMBERING SYSTEM

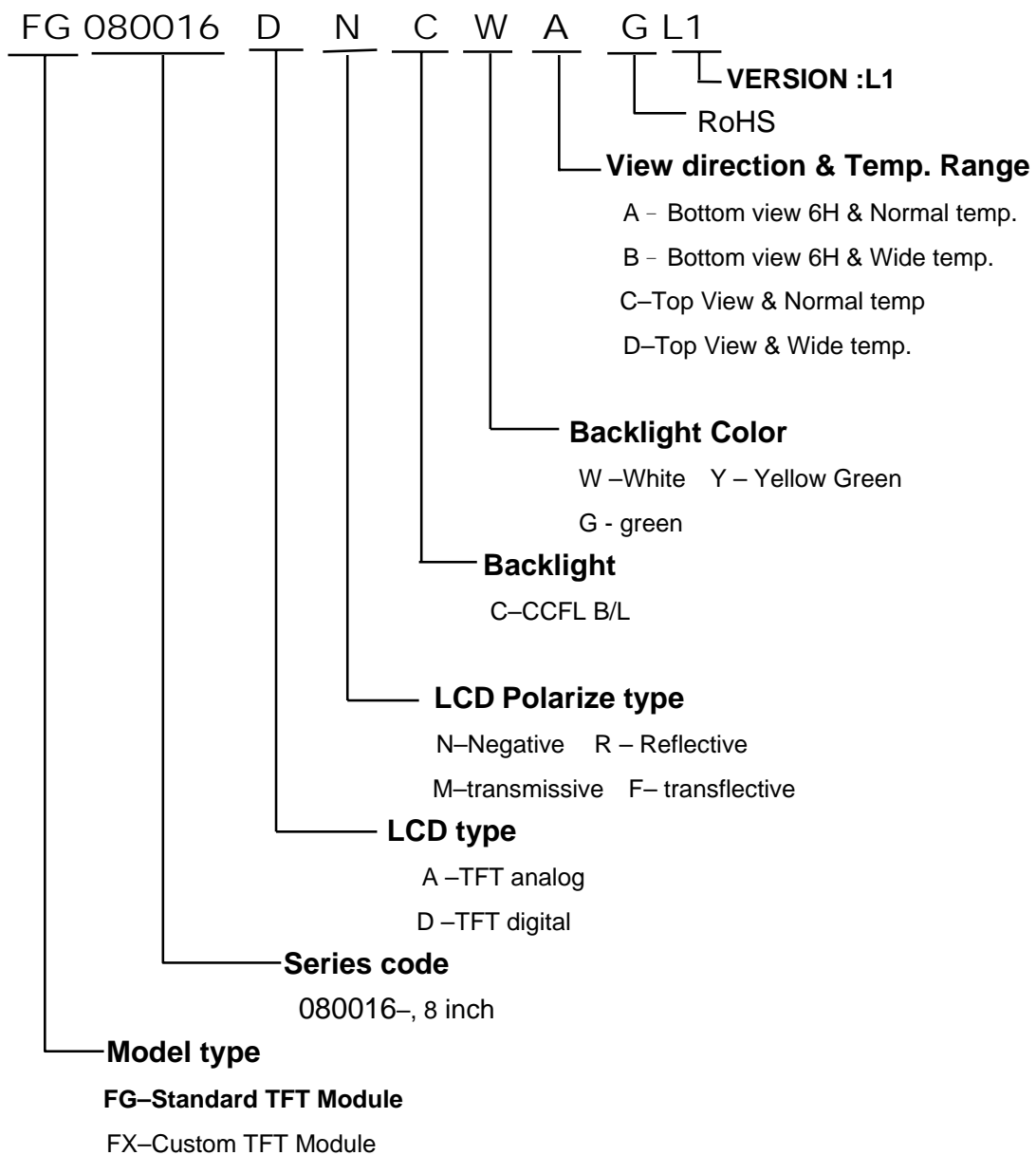

13. PRECAUTION FOR USING LCM

1. LIQUID CRYSTAL DISPLAY (LCD)

LCD is made up of glass, organic sealant, organic fluid, and polymer based polarizers. The following precautions should be taken when handling,

- (1). Keep the temperature within range of use and storage. Excessive temperature and humidity could cause polarization degradation, polarizer peel off or bubble.
- (2). Do not contact the exposed polarizers with anything harder than an HB pencil lead. To clean dust off the display surface, wipe gently with cotton, chamois or other soft material soaked in petroleum benzin.
- (3). Wipe off saliva or water drops immediately. Contact with water over a long period of time may cause polarizer deformation or color fading, while an active LCD with water condensation on its surface will cause corrosion of ITO electrodes.
- (4). Glass can be easily chipped or cracked from rough handling, especially at corners and edges.
- (5). Do not drive LCD with DC voltage.

2. Liquid Crystal Display Modules

2.1 Mechanical Considerations

LCM are assembled and adjusted with a high degree of precision. Avoid excessive shocks and do not make any alterations or modifications. The following should be noted.

- (1). Do not tamper in any way with the tabs on the metal frame.
- (2). Do not modify the PCB by drilling extra holes, changing its outline, moving its components or modifying its pattern.
- (3). Do not touch the elastomer connector, especially insert an backlight panel (for example, EL).
- (4). When mounting a LCM make sure that the PCB is not under any stress such as bending or twisting. Elastomer contacts are very delicate and missing pixels could result from slight dislocation of any of the elements.
- (5). Avoid pressing on the metal bezel, otherwise the elastomer connector could be deformed and lose contact, resulting in missing pixels.

2.2. Static Electricity

LCM contains CMOS LSI's and the same precaution for such devices should apply, namely

- (1). The operator should be grounded whenever he/she comes into contact with the module. Never touch any of the conductive parts such as the LSI pads, the copper leads on the PCB and the interface terminals with any parts of the human body.
- (2). The modules should be kept in antistatic bags or other containers resistant to static for storage.
- (3). Only properly grounded soldering irons should be used.
- (4). If an electric screwdriver is used, it should be well grounded and shielded from commutator sparks.

- (5) The normal static prevention measures should be observed for work clothes and working benches; for the latter conductive (rubber) mat is recommended.
- (6). Since dry air is inductive to statics, a relative humidity of 50-60% is recommended.

2.3 Soldering

- (1). Solder only to the I/O terminals.
- (2). Use only soldering irons with proper grounding and no leakage.
- (3). Soldering temperature : $280^{\circ}\text{C} \pm 10^{\circ}\text{C}$
- (4). Soldering time: 3 to 4 sec.
- (5). Use eutectic solder with resin flux fill.
- (6). If flux is used, the LCD surface should be covered to avoid flux spatters. Flux residue should be removed after wards.

2.4 Operation

- (1). Driving voltage should be kept within specified range; excess voltage shortens display life.
- (2). Response time increases with decrease in temperature.
- (3). Display may turn black or dark blue at temperatures above its operational range; this is (however not pressing on the viewing area) may cause the segments to appear "fractured".
- (4). Mechanical disturbance during operation (such as pressing on the viewing area) may cause the segments to appear "fractured".

2.5 Storage

If any fluid leaks out of a damaged glass cell, wash off any human part that comes into contact with soap and water. Never swallow the fluid. The toxicity is extremely low but caution should be exercised at all the time.

Confidential Document
14. OUTLINE DRAWING

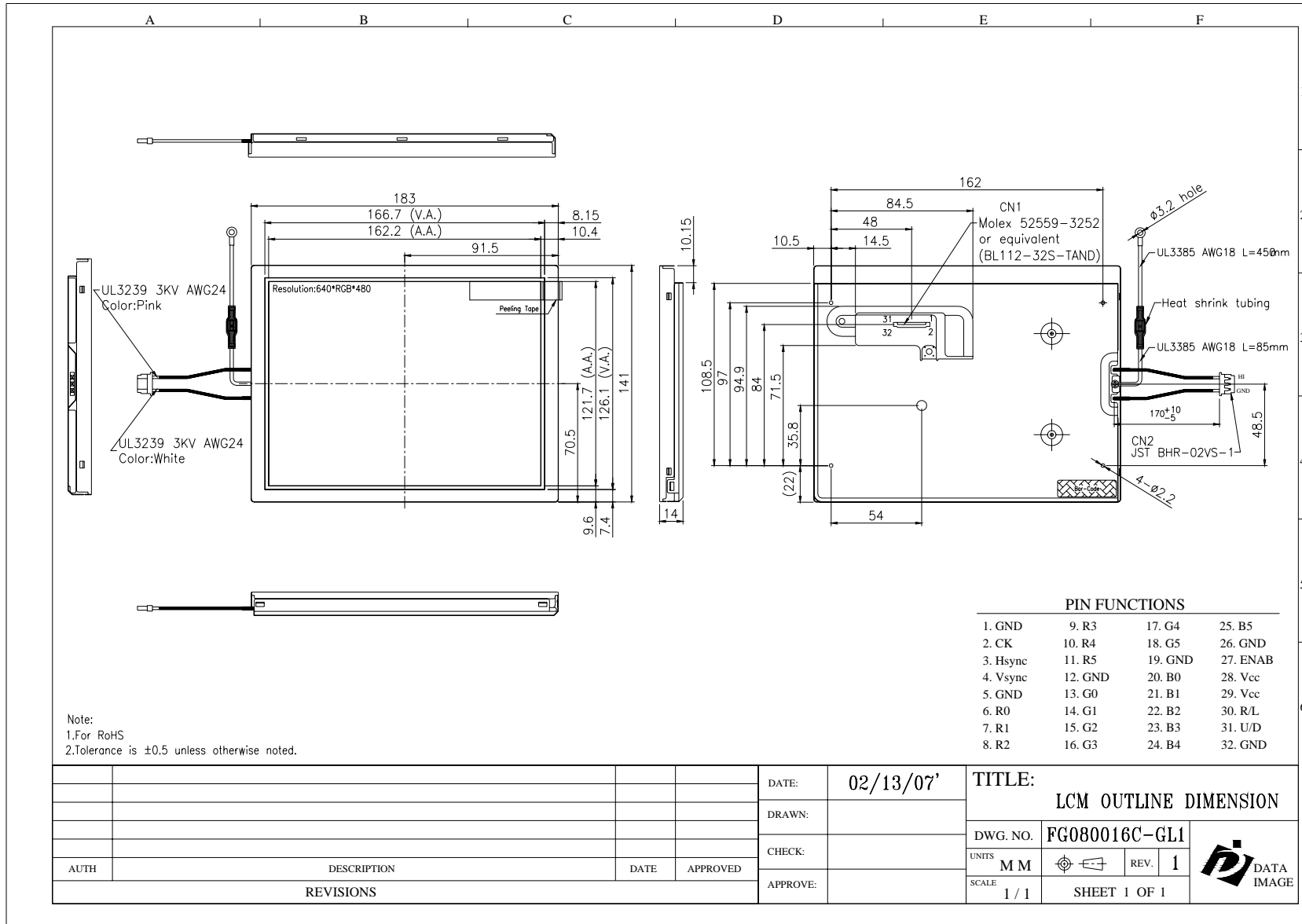

Note:
1.For RoHS
2.Tolerance is ±0.5 unless otherwise noted.

PIN FUNCTIONS			
1. GND	9. R3	17. G4	25. B5
2. CK	10. R4	18. G5	26. GND
3. Hsync	11. R5	19. GND	27. ENAB
4. Vsync	12. GND	20. B0	28. Vcc
5. GND	13. G0	21. B1	29. Vcc
6. R0	14. G1	22. B2	30. R/L
7. R1	15. G2	23. B3	31. U/D
8. R2	16. G3	24. B4	32. GND

					DATE:	02/13/07	TITLE:		LCM OUTLINE DIMENSION	
					DRAWN:		DWG. NO.		FG080016C-GL1	
					CHECK:		UNITS	M M	REV.	1
					APPROVE:		SCALE	1 / 1	SHEET 1 OF 1	
AUTH	DESCRIPTION	DATE	APPROVED							
REVISIONS										



Confidential Document
15.PACKAGE INFORMATION

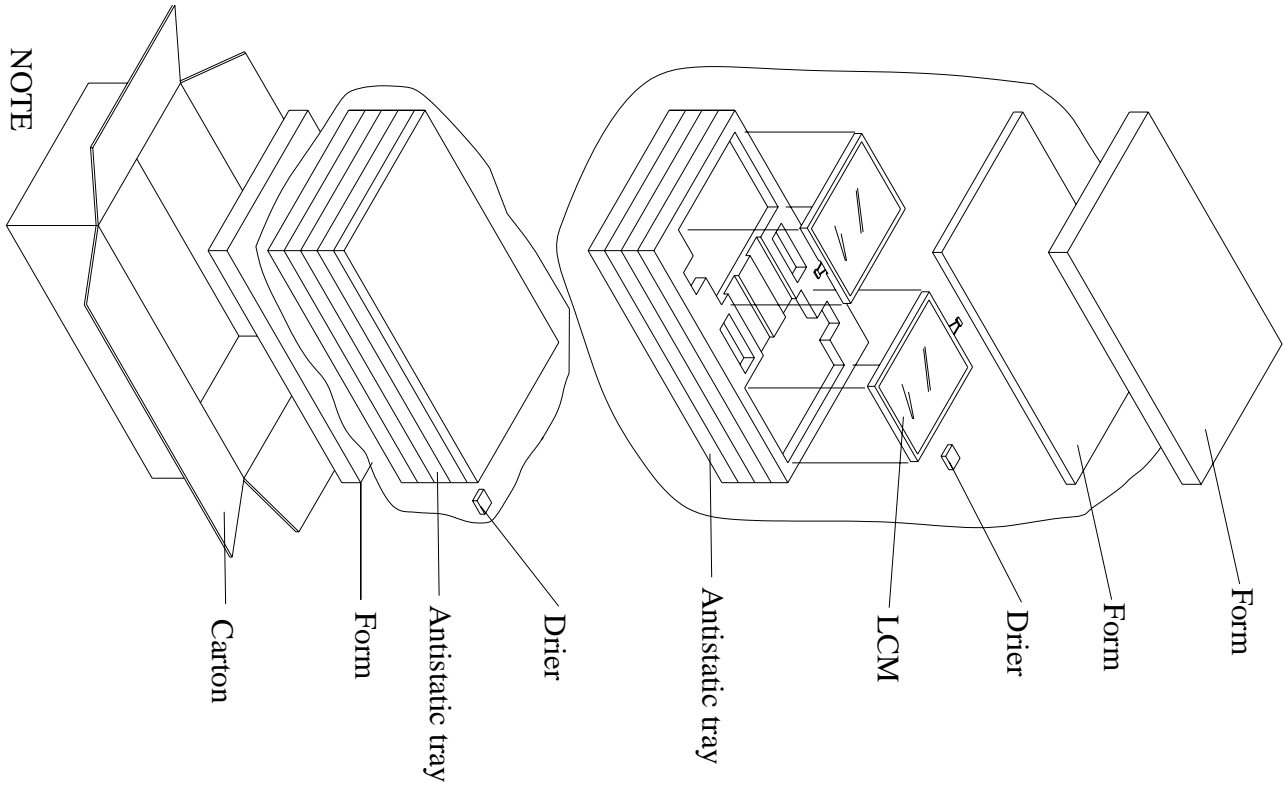

NOTE

Remove protection film before use it.

1 Antistatic tray = 2 pcs

1 Carton = 2 x 4 x 2 = 16 pcs

Carton size : 485L x 285W x 280H (mm)

Total Weight ÷ 9 kgw

8.0" TFT LCM PACKING

8.0" TFT LCM PACKING