



DATA IMAGE CORPORATION

TFT Module Specification

ITEM NO.: FG100232DSSWBG01

Table of Contents

- 1. COVER & CONTENTS 1
- 2. RECORD OF REVISION 2
- 3. APPLICATION..... 3
- 4. GENERAL SPECIFICATIONS 3
- 5. ABSOLUTE MAXIMUM RATINGS 3
- 6. ELECTRICAL CHARACTERISTICS 3
- 7. TIMING SPECIFICATIONS 5
- 8. OPTICAL CHARACTERISTIC 8
- 9. PIN CONNECTIONS 11
- 10. BLOCK DIAGRAM 13
- 11. QUALITY ASSURANCE 14
- 12. LCM PRODUCT LABEL DEFINE 15
- 13. LCM NUMBERING SYSTEM 16
- 14. PRECAUTIONS IN USE LCM 17
- 15. OUTLINE DRAWING 18
- 16 PACKAGE INFORMATION 19

Customer Companies	R&D Dept.	Q.C. Dept.	Eng. Dept.	Prod. Dept.
	<i>Jack</i>	<i>Eric</i>	<i>Gary</i>	<i>Huong</i>
Approved by	Version:	Issued Date:	Sheet Code:	Total Pages:
	B	03/FEB/12'		19



2. RECORD OF REVISION

Rev	Date	Item	Page	Comment
1	04/MAR/11'			Initial PRELIMINARY
2	29/APR/11'	12 16	15 19	1. Modify LCM PRODUCT LABEL DEFINE. 2. Modify PACKAGE INFORMATION
A	29/APR/11'	15	18	1. Revise OUTLINE DRAWING :from REV:1 to A. Release REV:A for production
B	03/FEB/12'	6.2	4	1. Add the Backlight Unit information

3. APPLICATION

DVD player, Car TV, Notebook PC

4. GENERAL SPECIFICATIONS

Parameter	Specifications	Unit
Screen Size	10.2 (diagonal)	inch
Display Format	1024(H) x (R,G,B) x 600(V)	dot
Active Area	222.72(H) x 130.5(V)	mm
Dot Pitch	0.0725(H) x 0.2175(V)	mm
Pixel Configuration	Stripe	
Outline Dimension	235(W) x 145.8(H) x 5.3(D)	mm
Surface treatment	Anti-glare	
Back-light	LED	
Display mode	Normally white	
Weight	250	g
View Angle direction	6 o'clock	

5. ABSOLUTE MAXIMUM RATINGS

Parameter	Symbol	MIN.	MAX.	Unit	Remark
Power supply voltage	V _{CC}	-0.3	4.0	V	
LED supply voltage	V _{LED}	-0.3	13.0	V	
Operating temperature	Top	-20	+70	°C	
Storage temperature	T _{st}	-30	+80	°C	

6. ELECTRICAL CHARACTERISTICS

6.1 TFT LCD Power Voltage

GND=0V, Ta=25°C

Parameter	Symbol	MIN.	Typ.	MAX.	Unit	Remark
Power Supply voltage for LCD	V _{CC}	+3.0	+3.3	+3.6	V	
Power Supply Current for LCD	I _{CC}		250	350	mA	Note 1
Power Supply voltage for LED	V _{LED}	11.5V	12	12.5	V	
Power Supply Current for LED	I _{LED}		300	450	mA	V _{LED} =12.0V
Ripple voltage	V _{RF}	-		100	mV _{P-P}	
LVDS Common Mode Voltage	V _{CM}	1.08	1.2	1.32	V	Note 2
LVDS Differential Input Voltage	VID	250	350	450	mV	Note 2
LVDS Threshold Voltage(high)	V _{TH}	-	-	100	mV	Note 2
LVDS Threshold Voltage(low)	V _{TL}	-100	-	-	mV	Note 2
ADJ frequency		20K	25K	30K	Hz	
ADJ input voltage	V _{IH}	3.0	-	3.3	V	
	V _{IL}	0	-	0.3	V	

Note 1: Under black pattern at $V_{cc} = 3.3\text{ V}$ and frame rate=60Hz

Note 2: LVDS signal

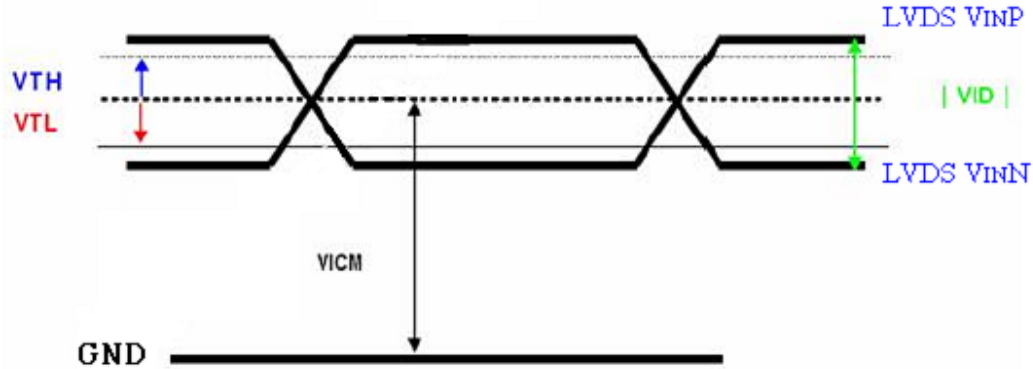

6.2 Backlight Unit

ITEM	Condition	Min	Typ.	MAX.	Unit	Remark
LED Life Time	$T_a=25$ Each serial=20mA	30000			Hr	Note 1 & 2 & 3

Note 1: Suggestion: Using the constant current control to avoid the leakage light and brightness quality issue.

Note 2: Definition of Led lifetime : Luminance < Initial luminance 50%

Note 3: Ifp Conditions : Pulse Width 10msec , Duty 1/10.

One of every LED must be satisfied as below figure.

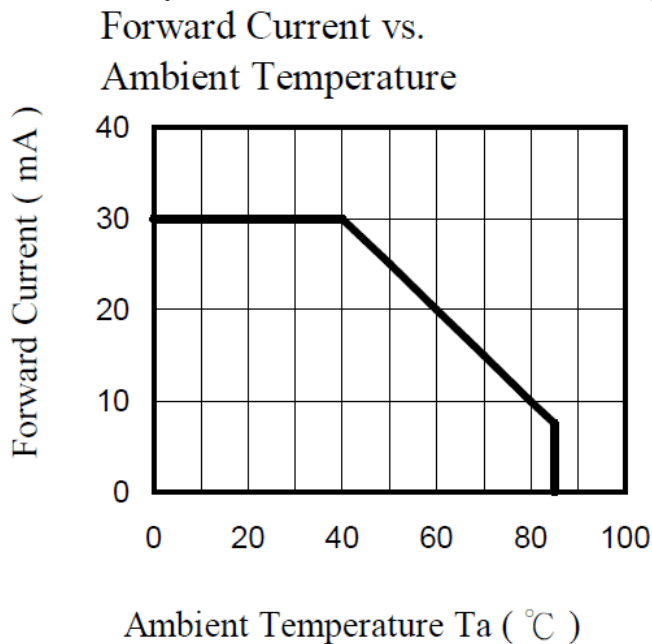

7. TIMING SPECIFICATIONS

7.1 Timing Specification

Item		Symbol	Min	Typ	Max	Unit	
DCLK Frequency		fCLKin	39.05	45	50	MHz	
DCLK Period		tCLKin	20	22.22	25.61	ns	
DE	Horizontal	Horizontal Total Time	t _H	1160	1200	1240	tCLK
		Horizontal Effective Time	t _{HA}	1024	1024	1024	tCLK
		Horizontal Blank Time	t _{HB}	136	176	216	tCLK
	Vertical	Frame Rate	fV	55	60	65	Hz
		Vertical Total Time	t _V	612	625	638	t _H
		Vertical Effective Time	t _{VA}	600	600	600	t _H
		Vertical Blank Time	t _{VB}	12	25	38	t _H

7.2 Timing sequence (Timing chart)

7.2.1 Horizontal Timing Sequence

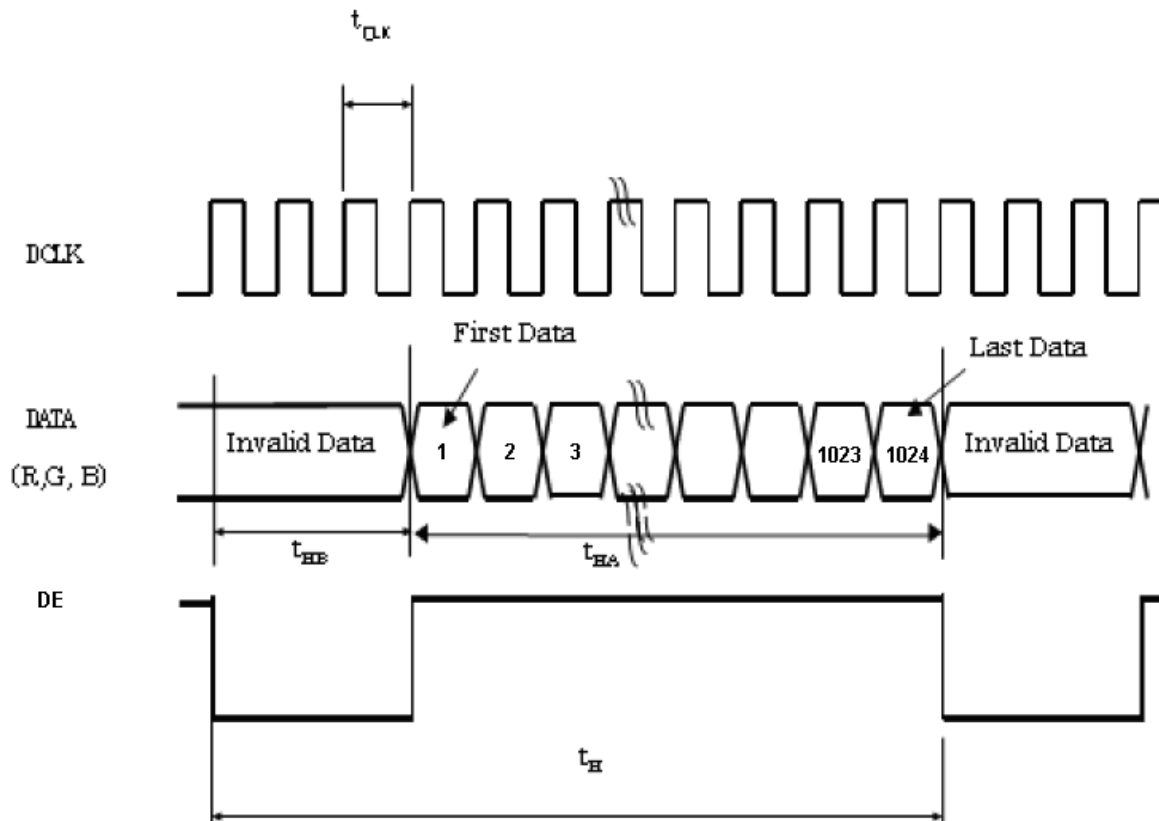

7.2.2 Vertical Timing Sequence

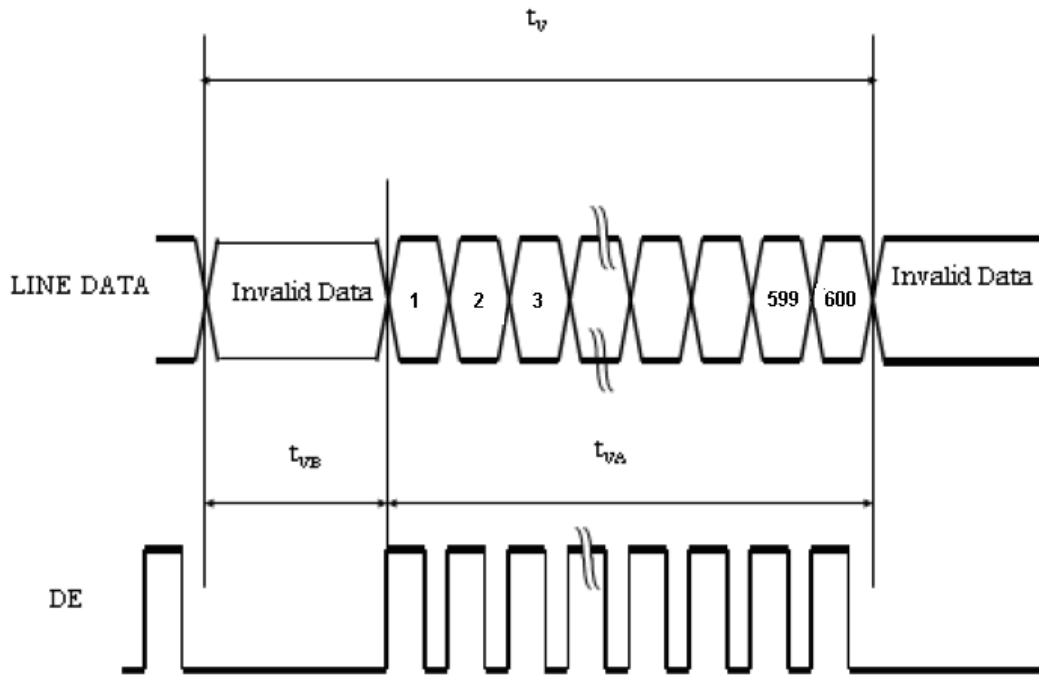

7.2.3 LVDS Input Data mapping

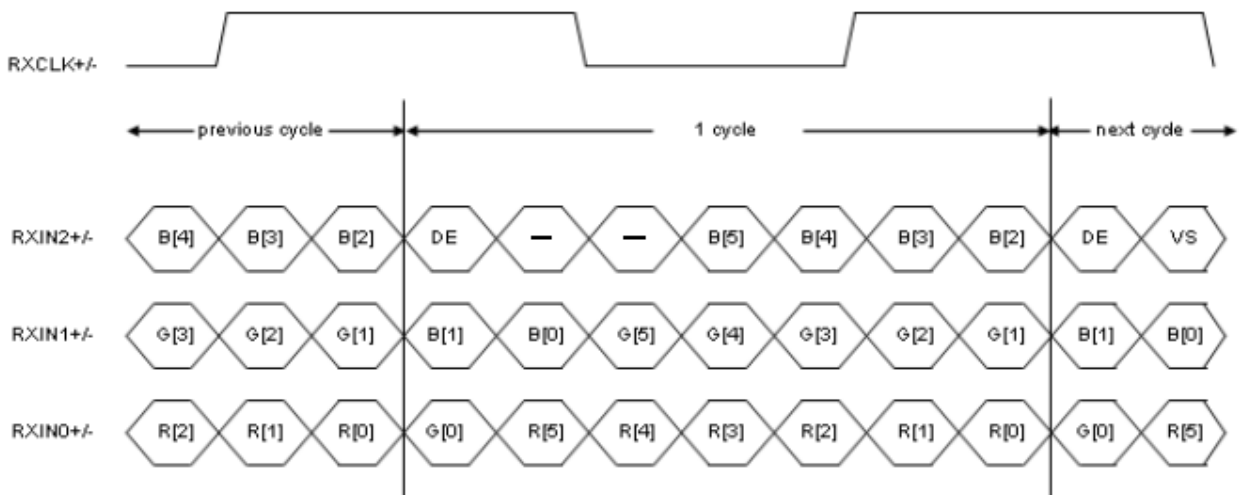

7.3 Color Data Input Assignment

		Data Signal																	
		Red					Green					Blue							
Color		R5	R4	R3	R2	R1	R0	G5	G4	G3	G2	G1	G0	B5	B4	B3	B2	B1	B0
Basic Colors	Black	0	0	0	0	0	0	0	0	0	0	0	0	0	0	0	0	0	0
	Red	1	1	1	1	1	1	0	0	0	0	0	0	0	0	0	0	0	0
	Green	0	0	0	0	0	0	1	1	1	1	1	1	0	0	0	0	0	0
	Blue	0	0	0	0	0	0	0	0	0	0	0	0	1	1	1	1	1	1
	Cyan	0	0	0	0	0	0	1	1	1	1	1	1	1	1	1	1	1	1
	Magenta	1	1	1	1	1	1	0	0	0	0	0	0	1	1	1	1	1	1
	Yellow	1	1	1	1	1	1	1	1	1	1	1	1	0	0	0	0	0	0
	White	1	1	1	1	1	1	1	1	1	1	1	1	1	1	1	1	1	1
Gray Scale of Red	Red(0) / Dark	0	0	0	0	0	0	0	0	0	0	0	0	0	0	0	0	0	0
	Red(1)	0	0	0	0	0	1	0	0	0	0	0	0	0	0	0	0	0	0
	Red(2)	0	0	0	0	1	0	0	0	0	0	0	0	0	0	0	0	0	0
	:	:	:	:	:	:	:	:	:	:	:	:	:	:	:	:	:	:	:
	:	:	:	:	:	:	:	:	:	:	:	:	:	:	:	:	:	:	:
	Red(61)	1	1	1	1	0	1	0	0	0	0	0	0	0	0	0	0	0	0
	Red(62)	1	1	1	1	1	0	0	0	0	0	0	0	0	0	0	0	0	0
Red(63)	1	1	1	1	1	1	0	0	0	0	0	0	0	0	0	0	0	0	
Gray Scale of Green	Green(0)/ Dark	0	0	0	0	0	0	0	0	0	0	0	0	0	0	0	0	0	0
	Green(1)	0	0	0	0	0	0	0	0	0	0	0	1	0	0	0	0	0	0
	Green(2)	0	0	0	0	0	0	0	0	0	0	1	0	0	0	0	0	0	0
	:	:	:	:	:	:	:	:	:	:	:	:	:	:	:	:	:	:	:
	:	:	:	:	:	:	:	:	:	:	:	:	:	:	:	:	:	:	:
	Green(61)	0	0	0	0	0	0	1	1	1	1	0	1	0	0	0	0	0	0
	Green(62)	0	0	0	0	0	0	1	1	1	1	1	0	0	0	0	0	0	0
Green(63)	0	0	0	0	0	0	1	1	1	1	1	1	0	0	0	0	0	0	
Gray Scale of Blue	Blue(0)/ Dark	0	0	0	0	0	0	0	0	0	0	0	0	0	0	0	0	0	0
	Blue (1)	0	0	0	0	0	0	0	0	0	0	0	0	0	0	0	0	0	1
	Blue (2)	0	0	0	0	0	0	0	0	0	0	0	0	0	0	0	0	1	0
	:	:	:	:	:	:	:	:	:	:	:	:	:	:	:	:	:	:	:
	:	:	:	:	:	:	:	:	:	:	:	:	:	:	:	:	:	:	:
	Blue (61)	0	0	0	0	0	0	0	0	0	0	0	0	1	1	1	1	0	1
	Blue (62)	0	0	0	0	0	0	0	0	0	0	0	0	1	1	1	1	1	0
Blue (63)	0	0	0	0	0	0	0	0	0	0	0	0	1	1	1	1	1	1	

8. OPTICAL CHARACTERISTIC

8-1. Specification:

Ta=25°C±2°C

Parameter	Symbol	Condition	MIN.	TYP.	MAX.	Unit	Remarks	
	Horizontal	$\theta_{x+} \sim \theta_{x-}$	Center	110	140	--	deg	Note 1,4
	Vertical	$\theta_{y+} \sim \theta_{y-}$	CR≥10	100	120	--		
Contrast Ratio	CR	at optimized viewing angle	320	400	--		Note 1,3	
Response time	Tr+Tf	Center	--	20	30	ms	Note 1,6	
Uniformity	B-uni	$\theta x = \theta y = 0^\circ$	70	80	--	%	Note 1,5	
Brightness	L	$\theta x = \theta y = 0^\circ$ ADJ=3.3V	360	400	--	cd/m ²	Note 1,2,4	
Chromaticity	x _W	Center $\theta x = \theta y = 0^\circ$	0.263	0.313	0.363		Note 1,7	
	y _W		0.279	0.329	0.379			
	x _R		0.518	0.568	0.618			
	y _R		0.286	0.336	0.386			
	x _G		0.296	0.346	0.396			
	y _G		0.524	0.574	0.624			
	x _B		0.105	0.155	0.205			
	y _B		0.058	0.108	0.158			
Image sticking	tis	2 hours	--	--	2	Sec	Note 8	

The following optical specifications shall be measured in a darkroom or equivalent state (ambient luminance ≤1 lux). The operation condition is VCC=3.3V, VLED=12.0V and ADJ=3.3V. The measurement method is shown in Note1.

Note1: The method of optical measurement:

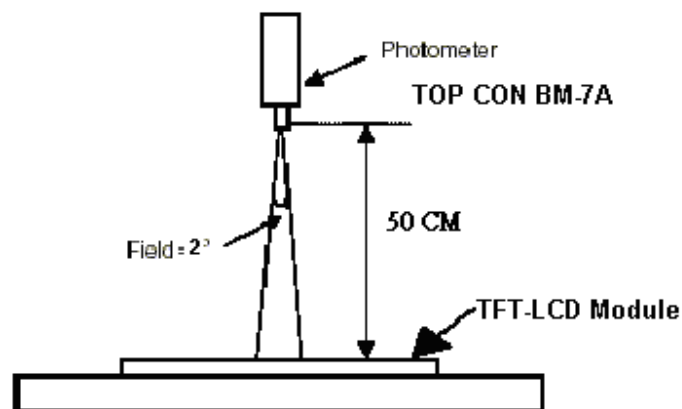

Note2: Measured at the center area of the panel and at the viewing angle of the $\theta_x = \theta_y = 0^\circ$

Note3: Definition of Contrast Ratio (CR):

$$CR = \frac{\text{Luminance with all pixels in white state}}{\text{Luminance with all pixels in Black state}}$$

Note4: Definition of Viewing Angle

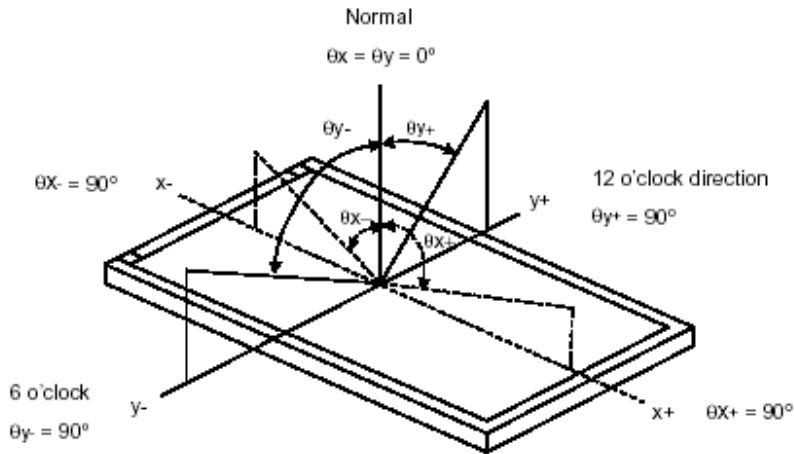

Note 5: Definition of Brightness Uniformity (B-uni):

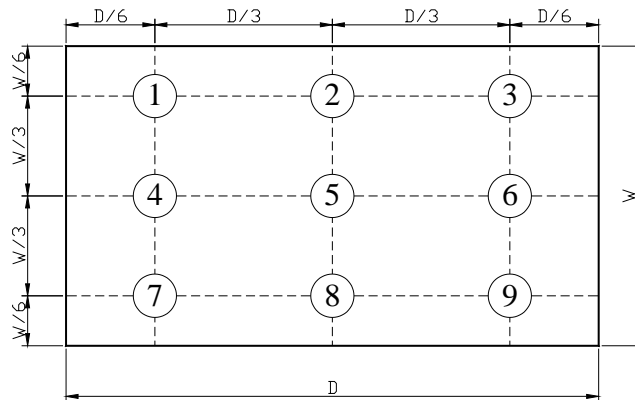

$$B\text{-uni} = \frac{\text{Minimum luminance of 9 points}}{\text{Maximum luminance of 9 points}} \quad (\text{Note 5}).$$

Note6: Definition of Response Time:

The Response Time is set initially by defining the "Rising Time (T_r)" and the "Falling Time (T_f)" respectively. T_r and T_f are defined as following figure.

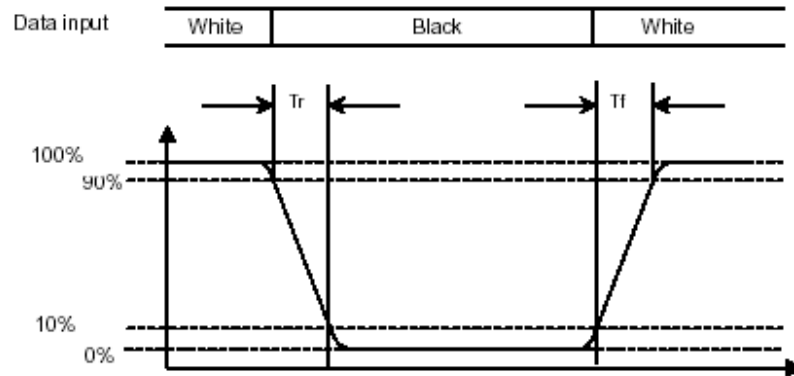

Note 7: Definition of Chromaticity:

The color coordinates (x_w, y_w) , (x_r, y_r) , (x_g, y_g) , and (x_b, y_b) are obtained with all pixels in the viewing field at white, red, green, and blue states, respectively.

Note 8: Definition of Image sticking (tis):

Continuously display the test pattern shown in the figure below for 2 hours. Then display a completely white screen. The previous image shall not persist more than 2 sec at 25 °C

Image sticking pattern

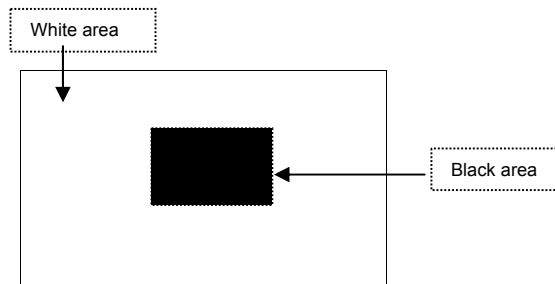

9. PIN CONNECTIONS

9.1 TFT PIN Connections

Pin No.	Symbol	I/O	Function	Remark
1	GND	P	Ground	
2	VCC	P	+3.3V power	
3	VCC	P	+3.3V power	
4	NC	—	NC	
5	ADJ	I	Adjust for LED brightness	Note 1,2
6	NC	—	NC	
7	NC	—	NC	
8	RXIN0-	I	LVDS differential data input(-) - channel 0	
9	RXIN0+	I	LVDS differential data input(+) - channel 0	
10	GND	P	Ground	
11	RXIN1-	I	LVDS differential data input(-) - channel 1	
12	RXIN1+	I	LVDS differential data input(+) - channel 1	
13	GND	P	Ground	
14	RXIN2-	I	LVDS differential data input(-) - channel 2	
15	RXIN2+	I	LVDS differential data input(+) - channel 2	
16	GND	P	Ground	
17	RXCLKIN-	I	LVDS differential clock input(-)	
18	RXCLKIN+	I	LVDS differential clock input(+)	
19	GND	P	Ground	
20	NC	—	NC	
21	NC	—	NC	
22	GND	P	Ground	
23	GND	P	Ground	
24	VLED	P	Power Supply for LED circuit (VLED=12.0V)	
25	VLED	P	Power Supply for LED circuit (VLED=12.0V)	
26	VLED	P	Power Supply for LED circuit (VLED=12.0V)	
27	NC	—	NC	
28	NC	—	NC	
29	NC	—	NC	
30	NC	—	NC	

Note 1: ADJ is brightness control Pin, Pulse duty the bigger the brighter.

Note 2: ADJ signal=0~3.3V, operation frequency:20KHz ~30KHz, ADJ pin should not connect to GND, it should pull-high if not adjust brightness.

$$F = 25\text{KHz} \pm 5\text{KHz}$$

$$T = 0.04\text{ms}$$

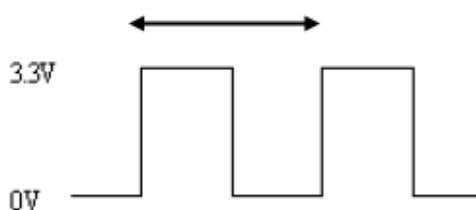

9.2 Power Signal Sequence

*1) Power Signal sequence:

$0.5\text{ms} < t_1 \leq 10\text{ms}$; $200\text{ms} \leq t_5$

$0 < t_2 \leq 50\text{ms}$; $200\text{ms} \leq t_6$

$0 < t_3 \leq 50\text{ms}$; $200\text{ms} \leq t_7$

$0 < t_4 \leq 10\text{ms}$

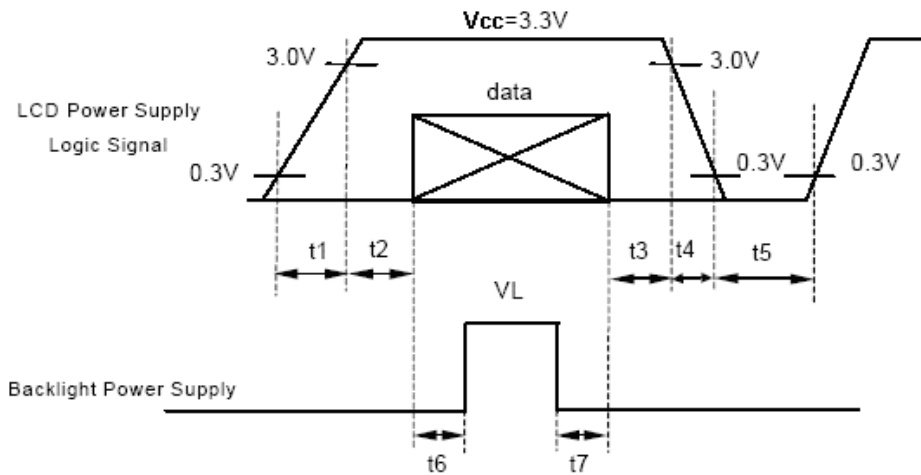

Data: RXIN0(+/-), RXIN1(+/-), RIN2(+/-),RXCLKIN(+/-)

*2)VCC-dip condition:

(1) When $2.7\text{V} \leq V_{CC} < 3.0\text{V}$, $t_d \leq 10\text{ms}$

(2) $V_{CC} > 3.0\text{V}$, VCC-dip condition should be the same with VCC-turn-on condition

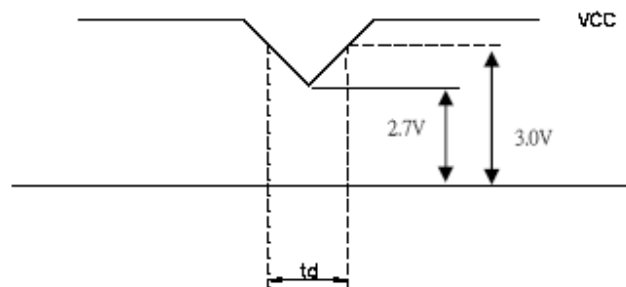

10. BLOCK DIAGRAM

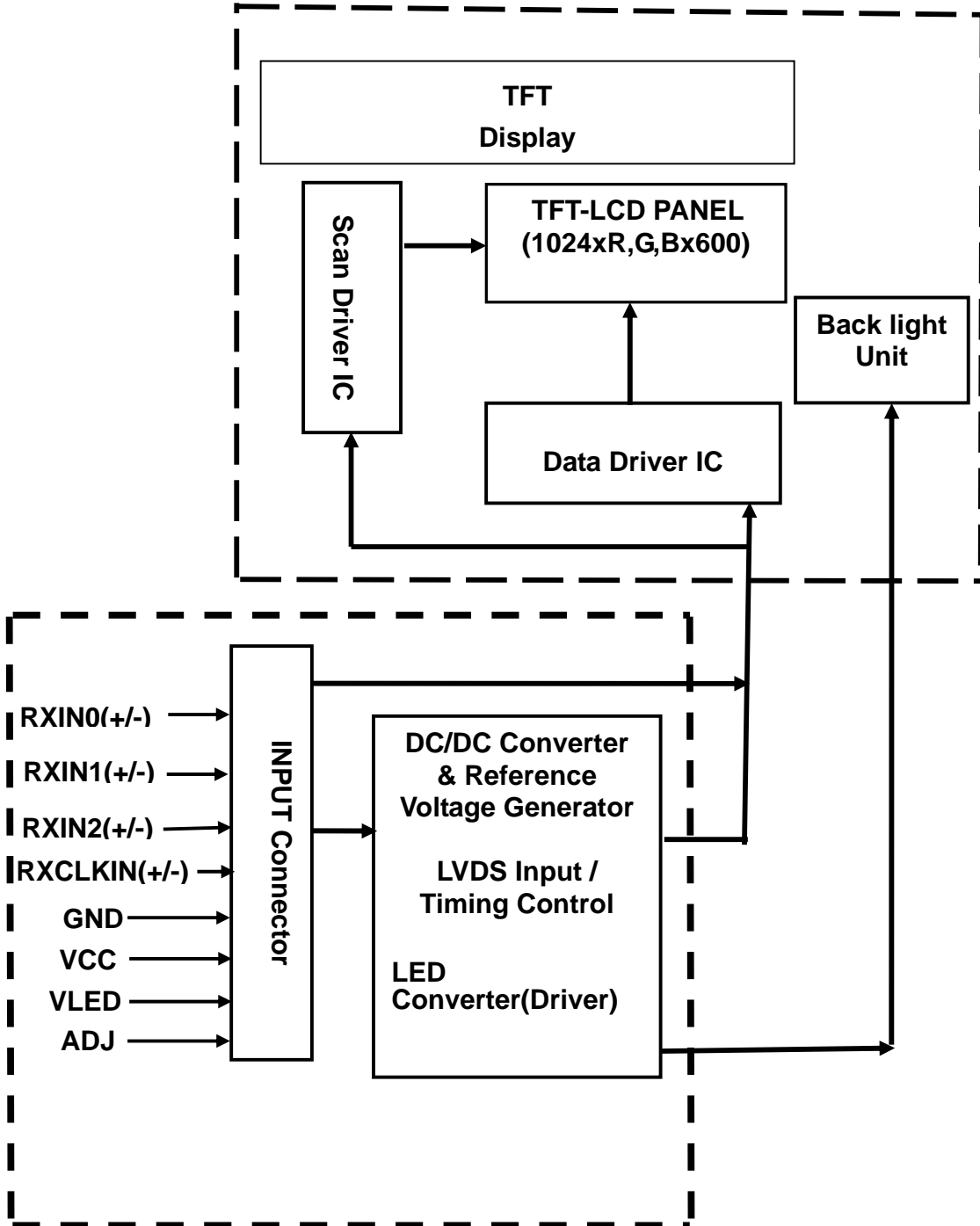

11. QUALITY ASSURANCE

11.1 Test Condition

11.1.1 Temperature and Humidity(Ambient Temperature)

Temperature : $25 \pm 5^{\circ}\text{C}$

Humidity : $65 \pm 5\%$

11.1.2 Operation

Unless specified otherwise, test will be conducted under function state.

11.1.3 Container

Unless specified otherwise, vibration test will be conducted to the product itself without putting it in a container.

11.1.4 Test Frequency

In case of related to deterioration such as shock test. It will be conducted only once.

11.1.5 Test Method

Reliability Test Item & Level		Test Level
No.	Test Item	
1	High Temperature Storage Test	T=80 , 240hrs
2	Low Temperature Storage Test	T=-30 , 240hrs
3	High Temperature Operation Test	T=70 , 240hrs
4	Low Temperature Operation Test	T=-20 , 240hrs
5	High Temperature and High Humidity Operation Test	T=60 , 90%RH, 240hrs
6	Thermal Cycling Test (No operation)	-30 → +25 → +80 , 100 Cycles 30 min 5 min 30 min
7	Vibration Test (No operation)	Frequency :10 ~ 55 Hz Amplitude :1.5 mm Sweep time : 11 mins Test Period: 6 Cycles for each direction of X, Y, Z
8	Shock Test (No operation)	100G, 6ms Direction: ±X, ±Y, ±Z Cycle: 3 times
9	Electrostatic Discharge Test (No operation)	150pF, 330Ω Contact : ± 8KV Air : ± 15KV

12. LCM PRODUCT LABEL DEFINE

Product Label style:

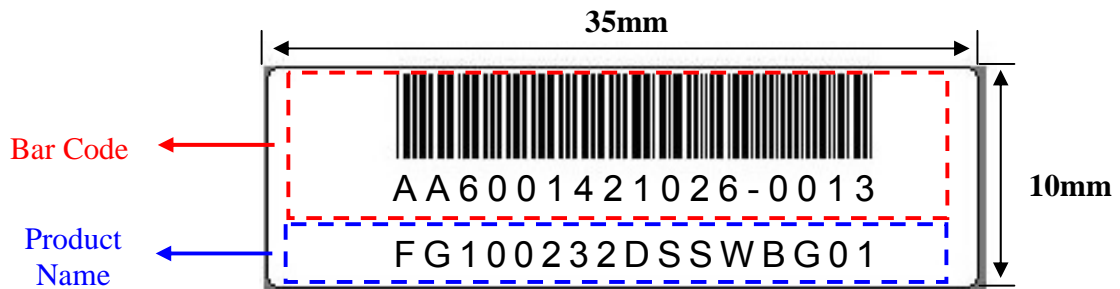

Barcode Define:

A A 6 0014 2 10 26-0013

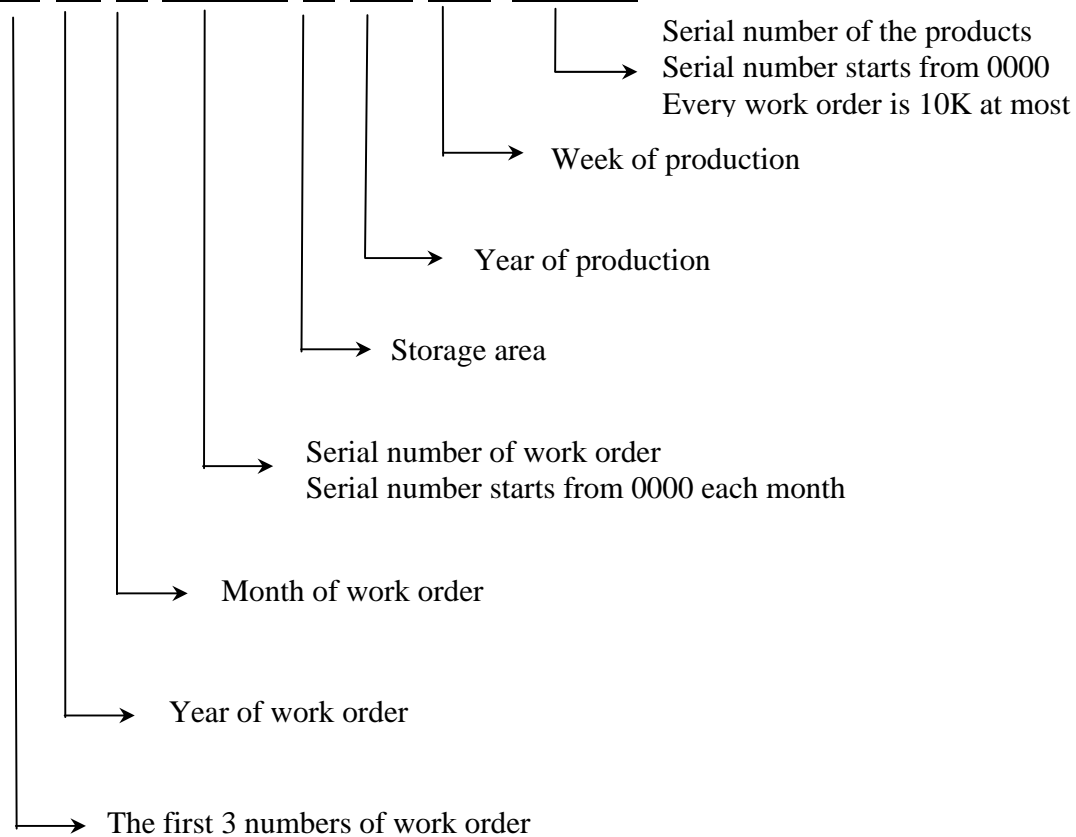

13. LCM NUMBERING SYSTEM

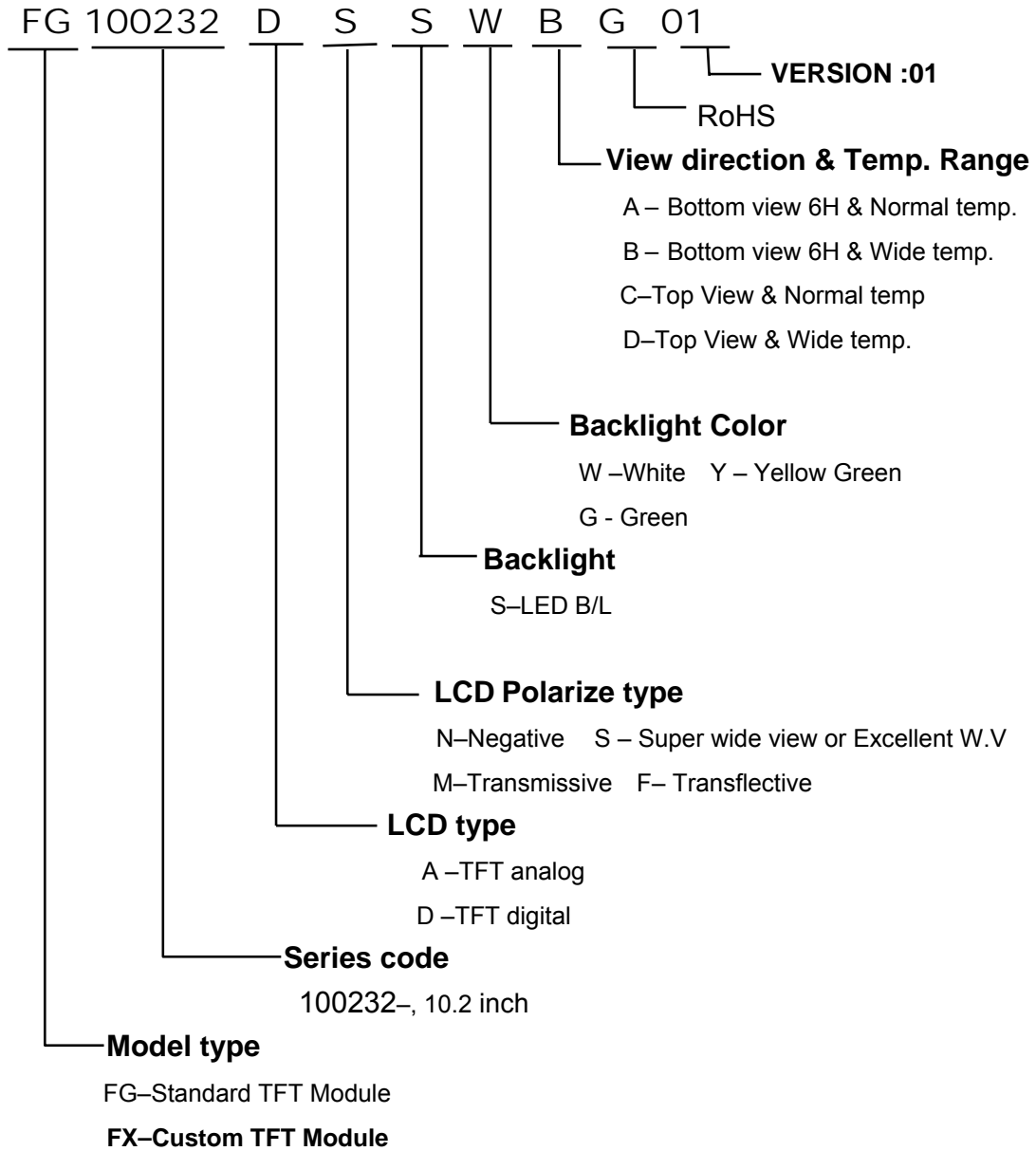

14. PRECAUTION FOR USING LCM

1. ASSEMBLY PRECAUTIONS

- (1) You must mount a module using holes arranged in four corners or four sides.
- (2) You should consider the mounting structure so that uneven force (ex. Twisted stress) is not applied to the module. And the case on which a module is mounted should have sufficient strength so that external force is not transmitted directly to the module.
- (3) Do not touch, push or rub the exposed polarizers with glass, tweezers or anything harder than HB pencil lead. And please do not rub with dust clothes with chemical treatment.
- (4) Wipe off saliva or water drops as soon as possible. Their long time contact with polarizer causes deformations and color fading.
- (5) Do not open the case because inside circuits do not have sufficient strength.
- (6) Please do not take a LCD module to pieces and reconstruct it. Resolving and reconstructing modules may cause them not to work well.
- (7) Please do not touch metal frames with bare hands and soiled gloves. A color change of the metal frames can happen during a long preservation of soiled LCD modules.
- (8) Please pay attention to handling lead wire of backlight so that it is not tugged in connecting with inverter.

2. OPERATING PRECAUTIONS

- (1) Please be sure to turn off the power supply before connecting and disconnecting signal input cable.
- (2) Please do not change variable resistance settings in LCD module. They are adjusted to the most suitable value. If they are changed, it might happen LCD does not satisfy the characteristics specification
- (3) Be careful for condensation at sudden temperature change. Condensation makes damage to polarizer or electrical contacted parts. And after fading condensation, smear or spot will occur.
- (4) When fixed patterns are displayed for a long time, remnant image is likely to occur.
- (5) Module has high frequency circuits. Sufficient suppression to the electromagnetic interference shall be done by system manufacturers. Grounding and shielding methods may be important to minimize the interference.
- (6) Please consider that LCD backlight takes longer time to become stable of radiation characteristics in low temperature than in room temperature.

3. ELECTROSTATIC DISCHARGE CONTROL

- (1) The operator should be grounded whenever he/she comes into contact with the module. Never touch any of the conductive parts such the copper leads on the PCB and the interface terminals with any

parts of the human body.

- (2) The modules should be kept in antistatic bags or other containers resistant to static for storage.
 - (3) Only properly grounded soldering irons should be used.
 - (4) If an electric screwdriver is used, it should be well grounded and shielded from commutator sparks.
 - (5) The normal static prevention measures should be observed for work clothes and working benches; for the latter conductive (rubber) mat is recommended
 - (6) Since dry air is inductive to statics, a relative humidity of 50-60% is recommended.
- ### 4. STORAGE PRECAUTIONS
- (1) When you store LCDs for a long time, it is recommended to keep the temperature between 0°C-40°C without the exposure of sunlight and to keep the humidity less than 90%RH.
 - (2) Please do not leave the LCDs in the environment of high humidity and high temperature such as 60°C 90%RH
 - (3) Please do not leave the LCDs in the environment of low temperature; below -20°C.
- ### 5. OTHERS
- (1) A strong incident light into LCD panel might cause display characteristics' changing inferior because of polarizer film, color filter, and other materials becoming inferior. Please do not expose LCD module direct sunlight and strong UV rays
 - (2) Please pay attention to a panel side of LCD module not to contact with other materials in preserving it alone.
 - (3) For the packaging box, please pay attention to the followings:
 - a. Please do not pile them up more than 5 boxes. (They are not designed so.) And please do not turn over.
 - b. Please handle packaging box with care not to give them sudden shock and vibrations. And also please do not throw them up.
 - c. Packing box and inner case for LCDs are made of cardboard. So please pay attention not to get them wet. (Such like keeping them in high humidity or wet place can occur getting them wet.)

6. LIMITED WARRANTY

Unless otherwise agreed between DATA IMAGE and customer, DATA IMAGE will replace or repair any of its LCD and LCM which is found to be defective electrically and visually when inspected in accordance with DATA IMAGE acceptance standards, for a period on one year from date of shipment. Confirmation of such date shall be based on freight documents. The warranty liability of DATA IMAGE is limited to repair and/or replacement on the terms set forth above. DATA IMAGE will not responsible for any subsequent or consequential events.

Confidential Document
15. OUTLINE DRAWING

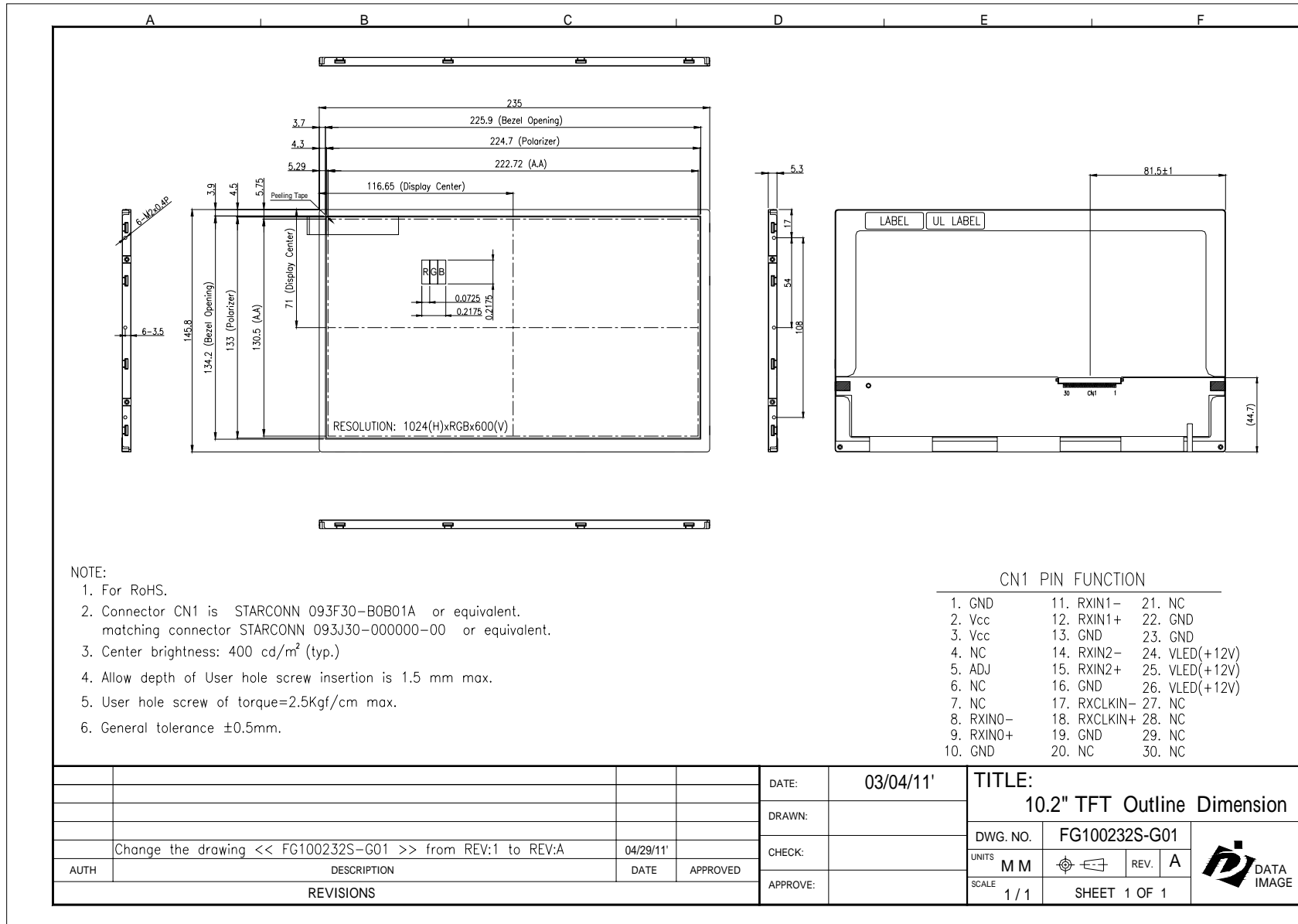

Confidential Document
16. PACKAGE INFORMATION

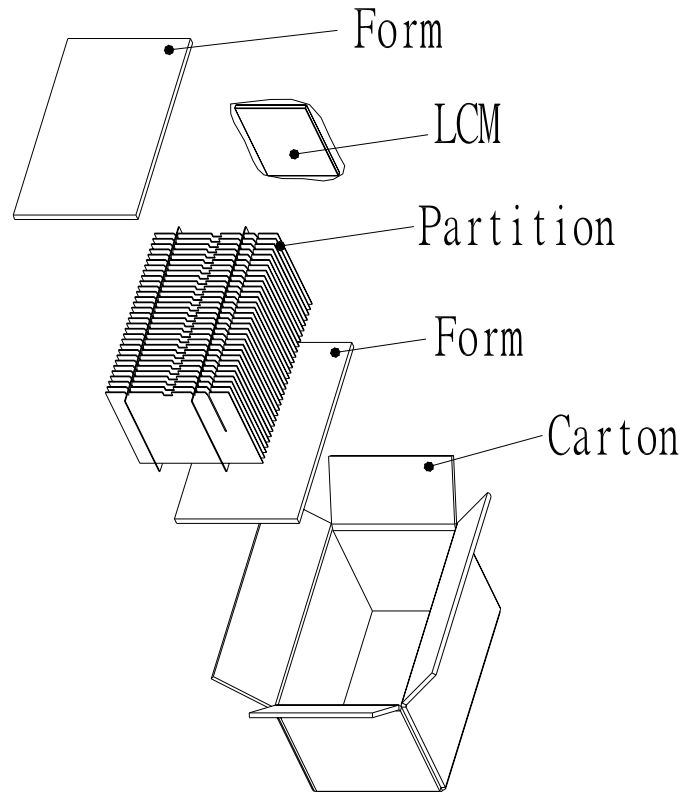

FG100232DSSWBG01 (250g) = 250 x 20 = 5000 g

Carton+Form+Inner layer = 1500 g

Total Weight = 6.5 kg

Carton size : 482L x 282W x 279H (mm)