

isc Silicon PNP Power Transistor
FJA4213
DESCRIPTION

- High Collector Breakdown Voltage-
: $V_{(BR)CEO} = -230V(\text{Min.})$
- Good Linearity of h_{FE}
- Complement to Type FJA4313
- Minimum Lot-to-Lot variations for robust device performance and reliable operation

APPLICATIONS

- Power amplifier applications
- Recommend for 80W high fidelity audio frequency amplifier output stage applications

ABSOLUTE MAXIMUM RATINGS($T_a=25^\circ\text{C}$)

SYMBOL	PARAMETER	VALUE	UNIT
V_{CBO}	Collector-Base Voltage	-230	V
V_{CEO}	Collector-Emitter Voltage	-230	V
V_{EBO}	Emitter-Base Voltage	-5	V
I_C	Collector Current-Continuous	-15	A
I_B	Base Current-Continuous	-1.5	A
P_C	Collector Power Dissipation @ $T_C=25^\circ\text{C}$	130	W
T_J	Junction Temperature	150	$^\circ\text{C}$
T_{stg}	Storage Temperature Range	-55~150	$^\circ\text{C}$

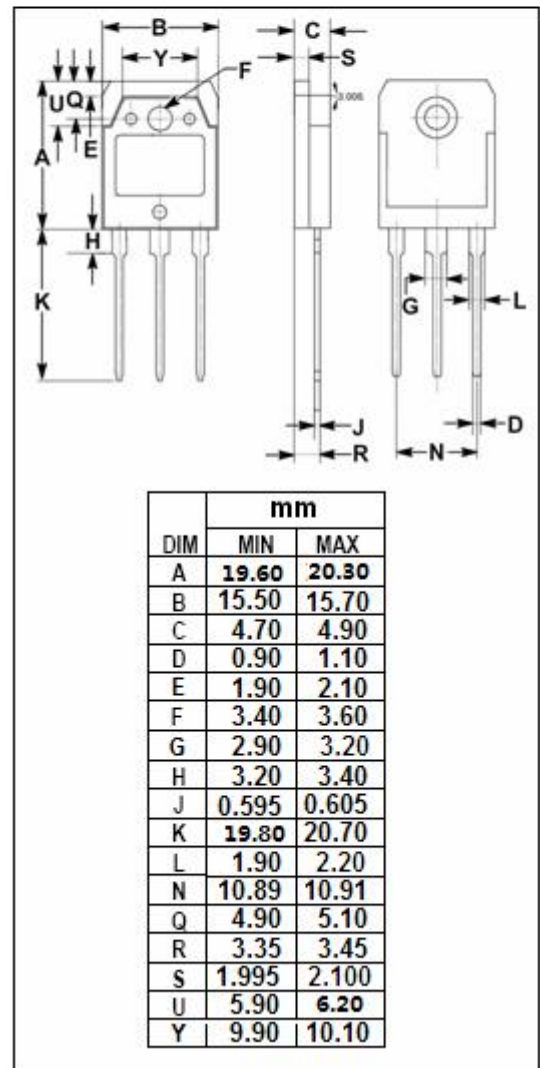
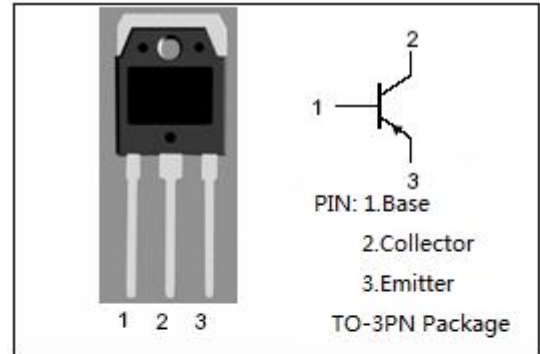

isc Silicon PNP Power Transistor

FJA4213

ELECTRICAL CHARACTERISTICS

 $T_C=25^\circ\text{C}$ unless otherwise specified

SYMBOL	PARAMETER	CONDITIONS	MIN	TYP.	MAX	UNIT
$V_{(BR)CEO}$	Collector-Emitter Breakdown Voltage	$I_C = -10\text{mA}$; $R_{BE} = \infty$	-230			V
$V_{(BR)CBO}$	Collector-Base Breakdown Voltage	$I_C = -5\text{mA}$; $I_E = 0$	-230			V
$V_{(BR)EBO}$	Emitter-Base Breakdown Voltage	$I_E = -5\text{mA}$; $I_C = 0$	-5			V
$V_{CE(sat)}$	Collector-Emitter Saturation Voltage	$I_C = -8\text{A}$; $I_B = -0.8\text{A}$			-3.0	V
$V_{BE(on)}$	Base-Emitter On Voltage	$I_C = -7\text{A}$; $V_{CE} = -5\text{V}$			-1.5	V
I_{CBO}	Collector Cutoff Current	$V_{CB} = -230\text{V}$; $I_E = 0$			-5	μA
I_{EBO}	Emitter Cutoff Current	$V_{EB} = -5\text{V}$; $I_C = 0$			-5	μA
h_{FE-1}	DC Current Gain	$I_C = -1\text{A}$; $V_{CE} = -5\text{V}$	55		160	
h_{FE-2}	DC Current Gain	$I_C = -7\text{A}$; $V_{CE} = -5\text{V}$	35			
C_{OB}	Output Capacitance	$I_E = 0$; $V_{CB} = -10\text{V}$; $f_{test} = 1.0\text{MHz}$		360		pF
f_T	Current-Gain—Bandwidth Product	$I_C = -1\text{A}$; $V_{CE} = -5\text{V}$		30		MHz

◆ h_{FE-1} Classifications

R	O
55-110	80-160

**Notice:**

ISC reserves the rights to make changes of the content herein the datasheet at any time without notification. The information contained herein is presented only as a guide for the applications of our products.

ISC products are intended for usage in general electronic equipment. The products are not designed for use in equipment which require specialized quality and/or reliability, or in equipment which could have applications in hazardous environments, aerospace industry, or medical field. Please contact us if you intend our products to be used in these special applications.

ISC makes no warranty or guarantee regarding the suitability of its products for any particular purpose, nor does ISC assume any liability arising from the application or use of any products, and specifically disclaims any and all liability, including without limitation special, consequential or incidental damages.