

PRELIMINARY
 Notice: This is not a final specification.
 Some parametric limits are subject to change.

MITSUBISHI POWER MOSFET

FL12KM-7A

HIGH-SPEED SWITCHING USE
 Nch POWER MOSFET

FL12KM-7A



- 10V DRIVE
- V_{DSS} 350V
- $r_{DS(ON)}(MAX)$ 0.4Ω
- I_D 7A
- V_{iso} 2000V

OUTLINE DRAWING

Dimensions in mm

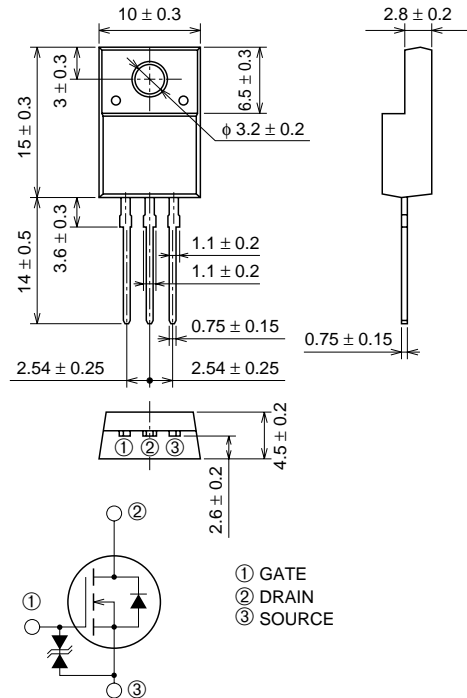

TO-220FN

APPLICATION

Inverter type fluorescent light sets, SMPS

MAXIMUM RATINGS (Tc = 25°C)

Symbol	Parameter	Conditions	Ratings	Unit
V_{DSS}	Drain-source voltage	$V_{GS} = 0V$	350	V
V_{GSS}	Gate-source voltage	$V_{DS} = 0V$	± 30	V
I_D	Drain current		12	A
I_{DM}	Drain current (Pulsed)		36	A
I_{DA}	Avalanche current (Pulsed)	$L = 200\mu H$	12	A
P_D	Maximum power dissipation		35	W
T_{ch}	Channel temperature		-55 ~ +150	°C
T_{stg}	Storage temperature		-55 ~ +150	°C
V_{iso}	Isolation voltage	AC for 1minute, Terminal to case	2000	V
—	Weight	Typical value	2.0	g

Aug. 1999

FL12KM-7A

HIGH-SPEED SWITCHING USE
Nch POWER MOSFET

PRELIMINARY
Notice: This is not a final specification.
Some parametric limits are subject to change.

ELECTRICAL CHARACTERISTICS (Tch = 25°C)

Symbol	Parameter	Test conditions	Limits			Unit
			Min.	Typ.	Max.	
V (BR) DSS	Drain-source breakdown voltage	Id = 1mA, VGS = 0V	350	—	—	V
V (BR) GSS	Gate-source breakdown voltage	IGS = ±100µA, VDS = 0V	±30	—	—	V
IGSS	Gate-source leakage current	VGS = ±25V, VDS = 0V	—	—	±10	µA
IDSS	Drain-source leakage current	VDS = 350V, VGS = 0V	—	—	1.0	mA
VGS (th)	Gate-source threshold voltage	Id = 1mA, VDS = 10V	2.0	3.0	4.0	V
rDS (ON)	Drain-source on-state resistance	Id = 6A, VGS = 10V	—	0.32	0.40	Ω
VDS (ON)	Drain-source on-state voltage	Id = 6A, VGS = 10V	—	1.90	2.40	V
yfs	Forward transfer admittance	Id = 6A, VDS = 10V	—	10	—	S
Ciss	Input capacitance	VDS = 25V, VGS = 0V, f = 1MHz	—	1050	—	pF
Coss	Output capacitance		—	150	—	pF
Crss	Reverse transfer capacitance		—	25	—	pF
td (on)	Turn-on delay time	VDD = 150V, Id = 6A, VGS = 10V, RGEN = RGS = 50Ω	—	20	—	ns
tr	Rise time		—	30	—	ns
td (off)	Turn-off delay time		—	160	—	ns
tf	Fall time		—	60	—	ns
VSD	Source-drain voltage	IS = 6A, VGS = 0V	—	1.5	2.0	V
Rth (ch-c)	Thermal resistance	Channel to case	—	—	3.57	°C/W

PERFORMANCE CURVES

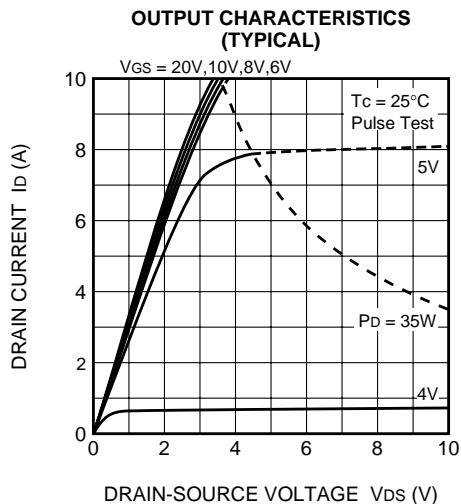
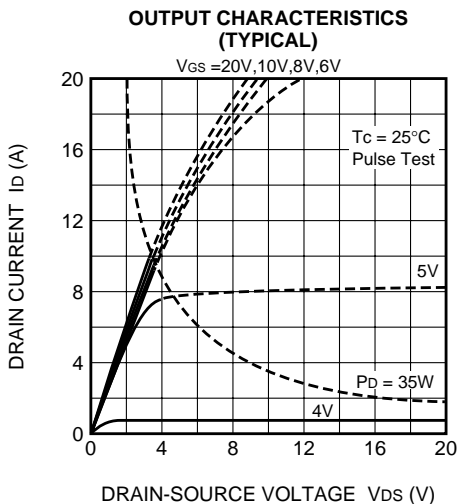
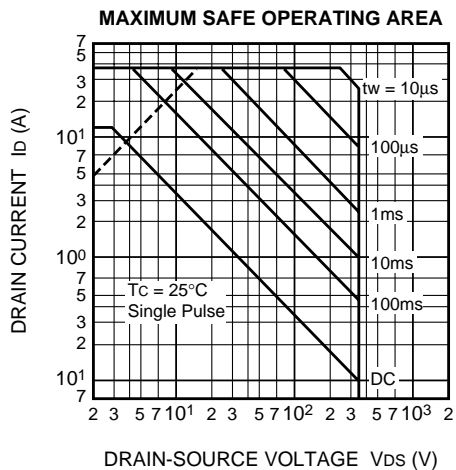
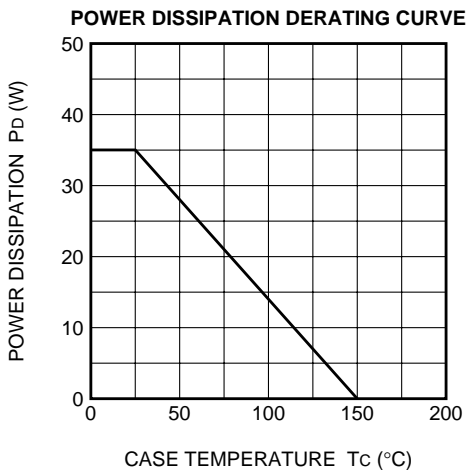

PRELIMINARY
 Notice: This is not a final specification.
 Some parametric limits are subject to change.

FL12KM-7A

HIGH-SPEED SWITCHING USE
 Nch POWER MOSFET

ON-STATE VOLTAGE VS. GATE-SOURCE VOLTAGE (TYPICAL)

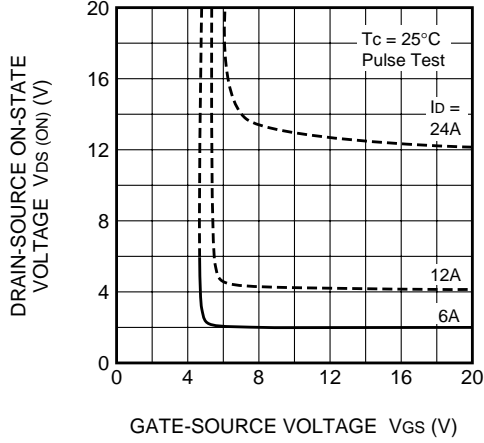

ON-STATE RESISTANCE VS. DRAIN CURRENT (TYPICAL)

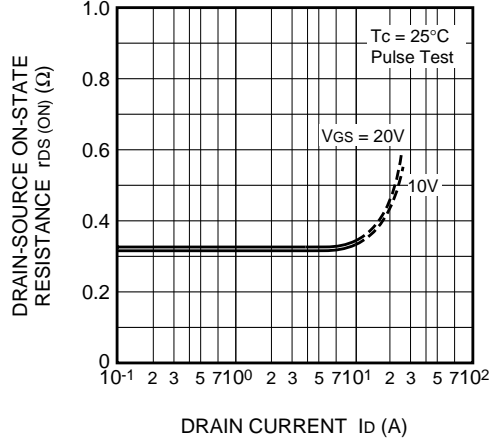

TRANSFER CHARACTERISTICS (TYPICAL)

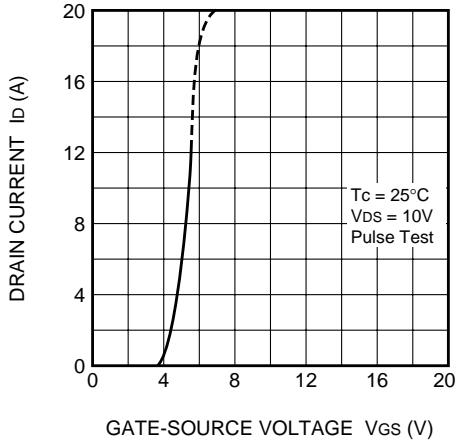

FORWARD TRANSFER ADMITTANCE VS. DRAIN CURRENT (TYPICAL)

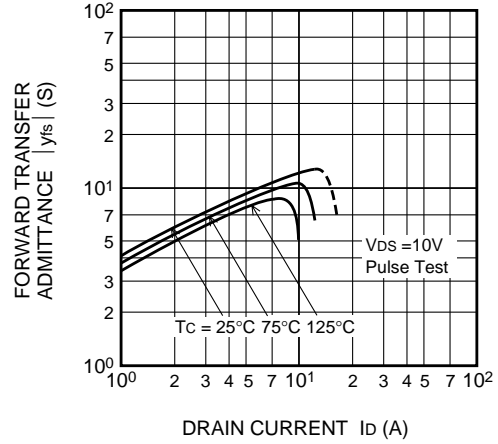

CAPACITANCE VS. DRAIN-SOURCE VOLTAGE (TYPICAL)

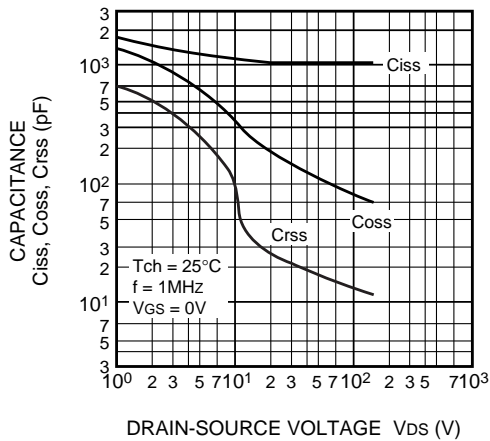

SWITCHING CHARACTERISTICS (TYPICAL)

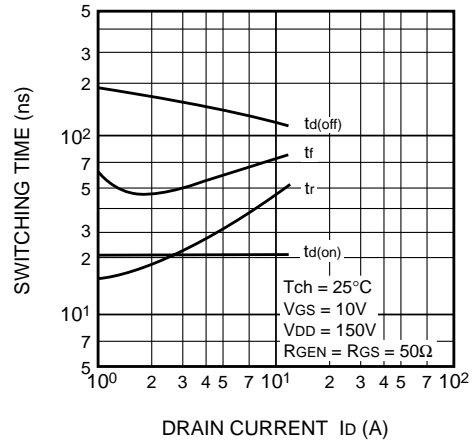

FL12KM-7A

HIGH-SPEED SWITCHING USE
Nch POWER MOSFET

PRELIMINARY
Notice: This is not a final specification.
Some parametric limits are subject to change.

www.DataSheet4U.com

GATE-SOURCE VOLTAGE VS. GATE CHARGE (TYPICAL)

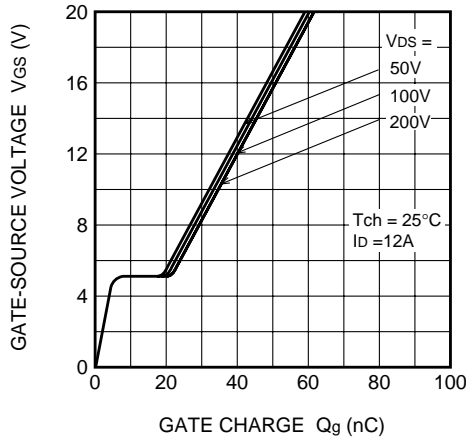

SOURCE-DRAIN DIODE FORWARD CHARACTERISTICS (TYPICAL)

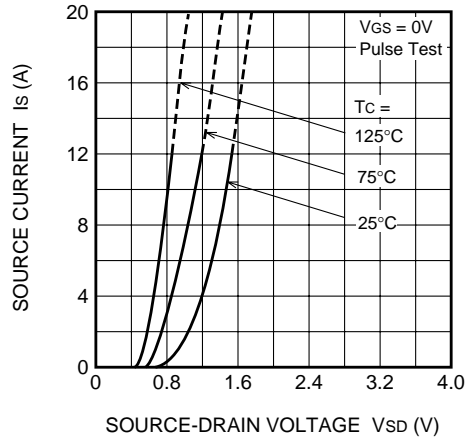

ON-STATE RESISTANCE VS. CHANNEL TEMPERATURE (TYPICAL)

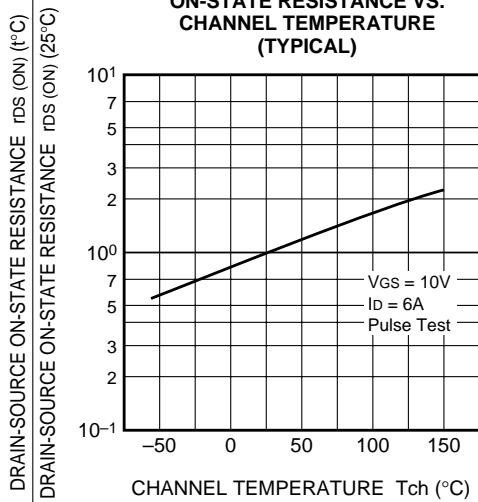

THRESHOLD VOLTAGE VS. CHANNEL TEMPERATURE (TYPICAL)

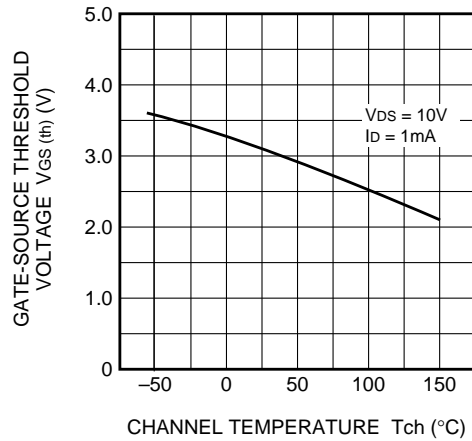

BREAKDOWN VOLTAGE VS. CHANNEL TEMPERATURE (TYPICAL)

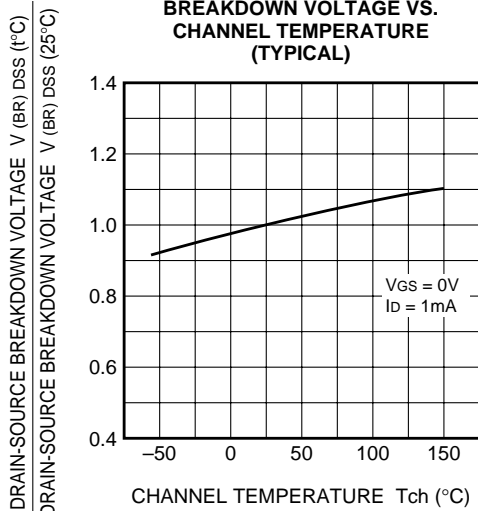

TRANSIENT THERMAL IMPEDANCE CHARACTERISTICS

