

FLC257MH-6

C-Band Power GaAs FET

FEATURES

- High Output Power: $P_{1dB} = 34.0\text{dBm(Typ.)}$
- High Gain: $G_{1dB} = 9.0\text{dB(Typ.)}$
- High PAE: $\eta_{add} = 36\%(Typ.)$
- Proven Reliability
- Hermetic Metal/Ceramic Package



DESCRIPTION

The FLC257MH-6 is a power GaAs FET that is designed for general purpose applications in the C-Band frequency range as it provides superior power, gain, and efficiency.

Eudyna stringent Quality Assurance Program assures the highest reliability and consistent performance.

ABSOLUTE MAXIMUM RATING (Ambient Temperature $T_a=25^\circ\text{C}$)

Item	Symbol	Condition	Rating	Unit
Drain-Source Voltage	V_{DS}		15	V
Gate-Source Voltage	V_{GS}		-5	V
Total Power Dissipation	P_T	$T_C = 25^\circ\text{C}$	15	W
Storage Temperature	T_{stg}		-65 to +175	$^\circ\text{C}$
Channel Temperature	T_{ch}		175	$^\circ\text{C}$

Eudyna recommends the following conditions for the reliable operation of GaAs FETs:

1. The drain-source operating voltage (V_{DS}) should not exceed 10 volts.
2. The forward and reverse gate currents should not exceed 17.8 and -1.2 mA respectively with gate resistance of 200Ω .
3. The operating channel temperature (T_{ch}) should not exceed 145°C .

ELECTRICAL CHARACTERISTICS (Ambient Temperature $T_a=25^\circ\text{C}$)

Item	Symbol	Test Conditions	Limit			Unit
			Min.	Typ.	Max.	
Saturated Drain Current	I_{DSS}	$V_{DS} = 5\text{V}, V_{GS} = 0\text{V}$	-	1000	1500	mA
Transconductance	g_m	$V_{DS} = 5\text{V}, I_{DS} = 600\text{mA}$	-	500	-	mS
Pinch-off Voltage	V_p	$V_{DS} = 5\text{V}, I_{DS} = 50\text{mA}$	-1.0	-2.0	-3.5	V
Gate Source Breakdown Voltage	V_{GSO}	$I_{GS} = -50\mu\text{A}$	-5	-	-	V
Output Power at 1dB G.C.P.	P_{1dB}	$V_{DS} = 10\text{V},$ $I_{DS} = 0.6 I_{DSS} (Typ.),$ $f = 6.4\text{ GHz}$	32.5	34.0	-	dBm
Power Gain at 1dB G.C.P.	G_{1dB}		8.0	9.0	-	dB
Power-added Efficiency	η_{add}		-	36	-	%
Thermal Resistance	R_{th}	Channel to Case	-	8	10	$^\circ\text{C/W}$

CASE STYLE: MH

G.C.P.: Gain Compression Point

FLC257MH-6

C-Band Power GaAs FET

POWER DERATING CURVE

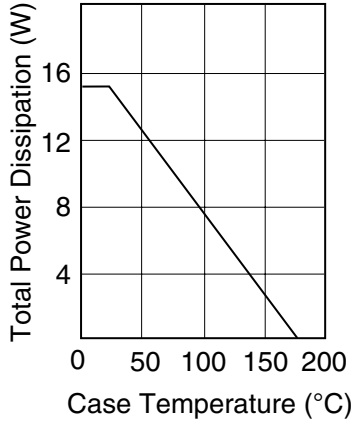

DRAIN CURRENT vs. DRAIN-SOURCE VOLTAGE

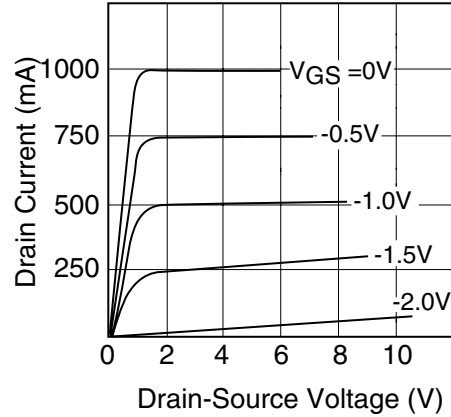

OUTPUT POWER & IM₃ vs. INPUT POWER

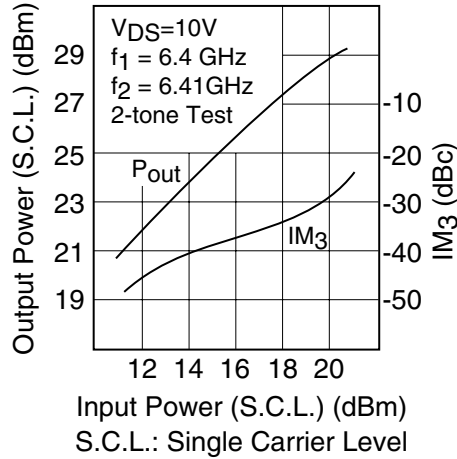

OUTPUT POWER vs. INPUT POWER

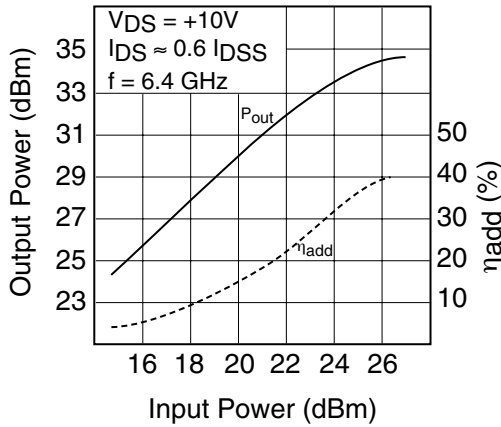

P_{1dB} & η_{add} vs. V_{DS}

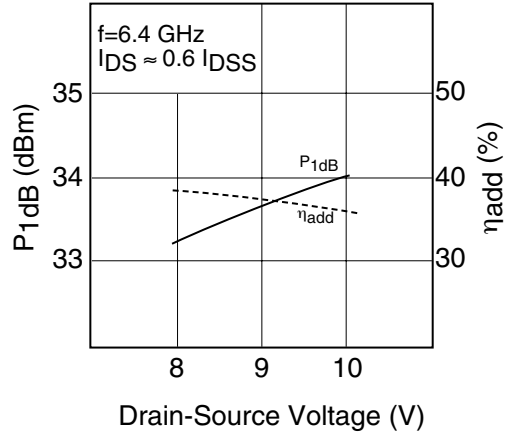

FLC257MH-6

C-Band Power GaAs FET

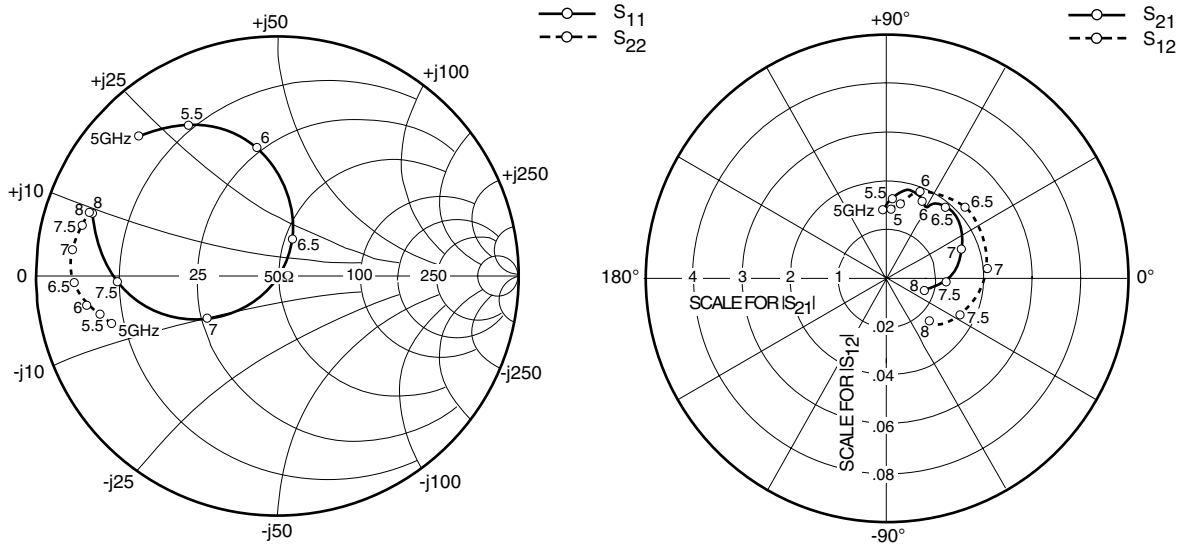

S-PARAMETERS

$V_{DS} = 10V, I_{DS} = 600mA$

FREQUENCY (MHZ)	S11		S21		S12		S22	
	MAG	ANG	MAG	ANG	MAG	ANG	MAG	ANG
500	.937	-142.8	7.241	109.5	.020	30.3	.351	-157.1
5000	.818	134.9	1.418	91.8	.029	86.1	.719	-163.9
5500	.729	120.3	1.596	85.8	.031	79.7	.751	-167.5
6000	.542	99.1	1.737	64.9	.038	69.2	.800	-170.6
6500	.166	67.8	1.912	50.3	.044	41.5	.839	-178.0
7000	.338	-148.2	1.664	20.5	.042	5.6	.856	172.9
7500	.667	-177.6	1.231	-1.8	.034	-25.6	.832	165.7
8000	.814	161.6	.810	-16.0	.025	-44.4	.825	160.9

FLC257MH-6

C-Band Power GaAs FET

Case Style "MH" Metal-Ceramic Hermetic Package

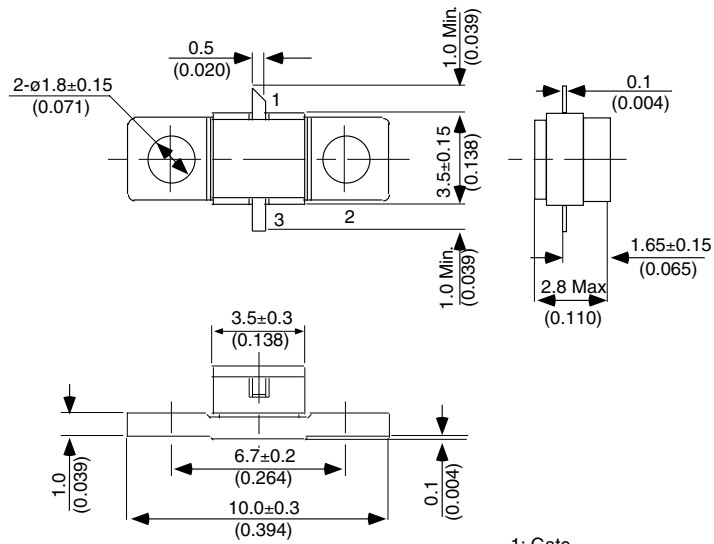

1: Gate
2: Source (Flange)
3: Drain
Unit: mm (Inches)