

FLC317MG-4

High Voltage - High Power GaAs FET

FEATURES

- High Output Power: P1dB=34.8dBm(Typ.)
- High Gain: G1dB=9.5dB(Typ.)
- High PAE: η_{add} =37%(Typ.)
- Proven Reliability
- Hermetic Metal/Ceramic Package

DESCRIPTION

The FLC317MG-4 is a power GaAs FET that is designed for general purpose application in the C-Band frequency range as it provides superior power, gain, and efficiency.

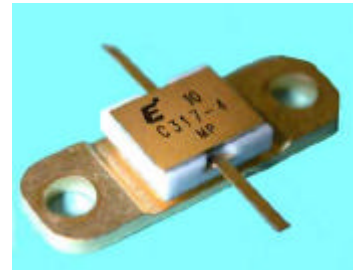

EUD stringent Quality Assurance Program assures the highest reliability and consistent performance.

ABSOLUTE MAXIMUM RATING (Case Temperature Tc=25°C)

Item	Symbol	Rating	Unit
Drain-Source Voltage	VDS	15	V
Gate-Source Voltage	VGS	-5	V
Total Power Dissipation	PTot	15	W
Storage Temperature	Tstg	-65 to +175	°C
Channel Temperature	Tch	175	°C

RECOMMENDED OPERATING CONDITION (Case Temperature Tc=25°C)

Item	Symbol	Condition	Limit	Unit
DC Input Voltage	VDS		10	V
Forward Gate Current	IGF	RG=100W	<19.4	mA
Reverse Gate Current	IGR	RG=100W	>-2.0	mA
Operating channel temperature	Tch		145	°C

ELECTRICAL CHARACTERISTICS (Case Temperature Tc=25°C)

Item	Symbol	Condition	Limit			Unit
			Min.	Typ.	Max.	
Saturated Drain Current	IDSS	VDS=5V, VGS=0V	-	1200	1800	mA
Transconductance	gm	VDS=5V, IDS=800mA	-	600	-	mS
Pinch-off Voltage	Vp	VDS=5V, IDS=60mA	-1.0	-2.0	-3.5	V
Gate-Source Breakdown Voltage	VGSO	IGS=-60uA	-5.0	-	-	V
Output Power at 1dB G.C.P.	P1dB	VDS=10V	33.5	34.8	-	dBm
Power Gain at 1dB G.C.P.	G1dB	f=4.2GHz	8.5	9.5	-	dB
Power-added Efficiency	hadd	IDS(DC)=0.6IDSS(Typ)	-	37.0	-	%
Thermal Resistance	Rth	Channel to Case	-	8.0	10.0	°C/W

ESD	Class III	2000 V~
-----	-----------	---------

CASE STYLE: MG

Note : Based on EIAJ ED-4701 C-111A(C=100pF, R=1.5kΩ)

FLC317MG-4

High Voltage - High Power GaAs FET

POWER DERATING CURVE

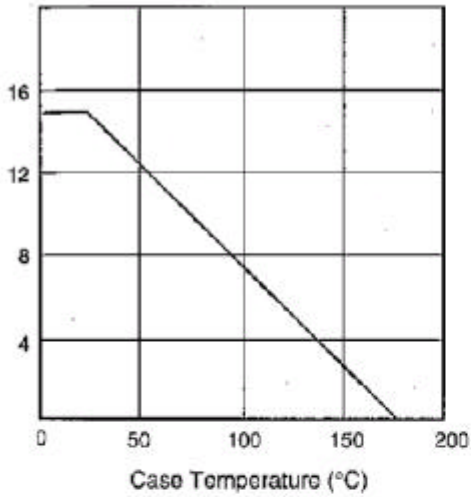

DRAIN CURRENT vs. DRAIN-SOURCE VOLTAGE

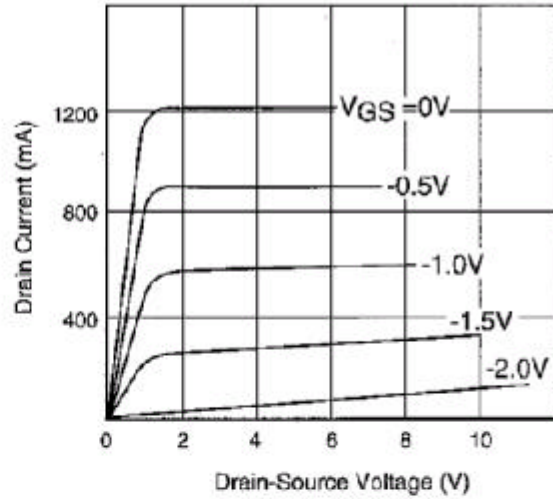

OUTPUT POWER vs. INPUT POWER

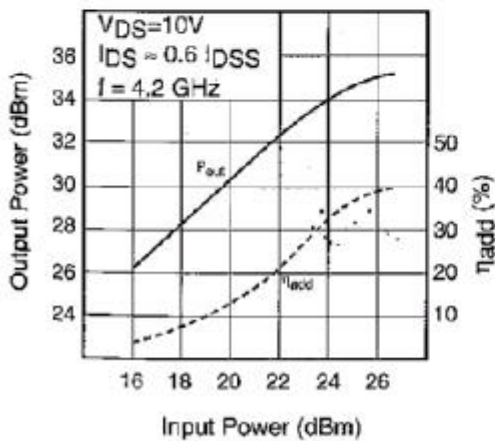

P_{1dB} & η_{add} vs. V_{DS}

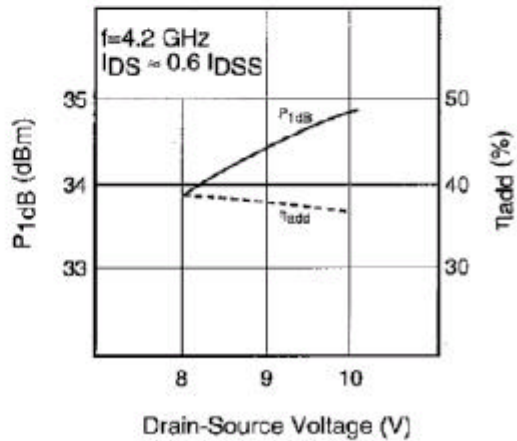

FLC317MG-4

High Voltage - High Power GaAs FET

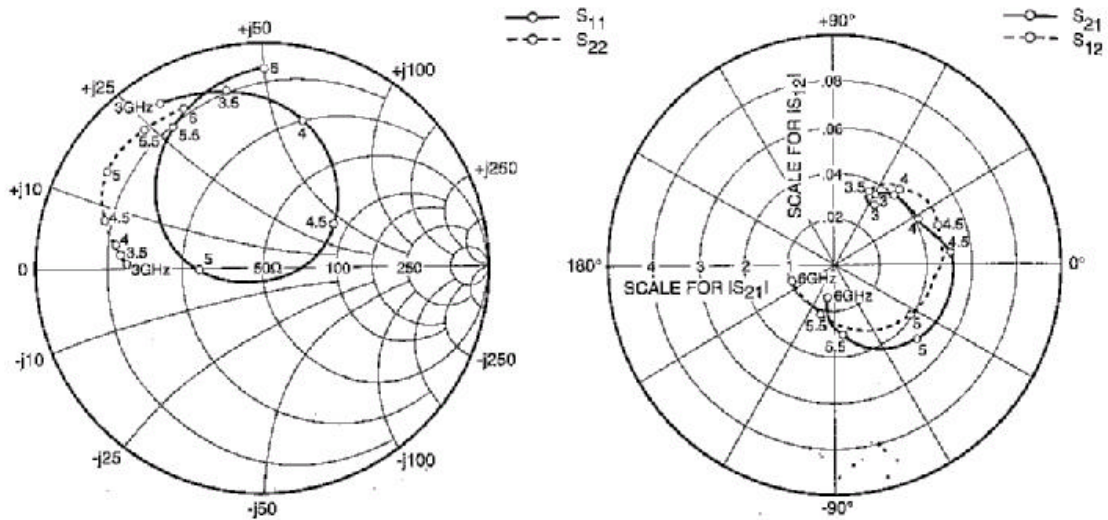

S-PARAMETERS

$V_{DS} = 10V, I_{DS} = 720mA$

FREQUENCY (MHZ)	S11		S21		S12		S22	
	MAG	ANG	MAG	ANG	MAG	ANG	MAG	ANG
500	.924	-159.1	6.908	99.0	.018	29.7	.416	-169.6
1000	.919	177.0	3.885	86.9	.020	34.4	.450	-171.2
1500	.910	162.1	2.612	80.1	.022	46.1	.484	-173.1
2000	.899	149.3	2.106	73.4	.023	54.3	.522	-174.6
2500	.885	136.4	1.888	67.2	.027	63.1	.555	-177.2
3000	.853	120.9	1.776	59.9	.031	57.3	.588	179.3
3500	.799	100.9	2.000	48.6	.035	65.0	.614	175.0
4000	.676	74.2	2.075	28.7	.043	49.0	.648	170.6
4500	.370	30.8	2.544	6.1	.048	20.2	.719	162.8
5000	.276	-178.7	2.403	-41.9	.039	-34.5	.803	147.6
5500	.739	121.7	1.520	-84.2	.022	-107.4	.800	129.9
6000	.885	89.2	.747	-103.9	.021	-163.4	.785	115.7

Eudyna

FLC317MG-4

High Voltage - High Power GaAs FET

Package Out Line

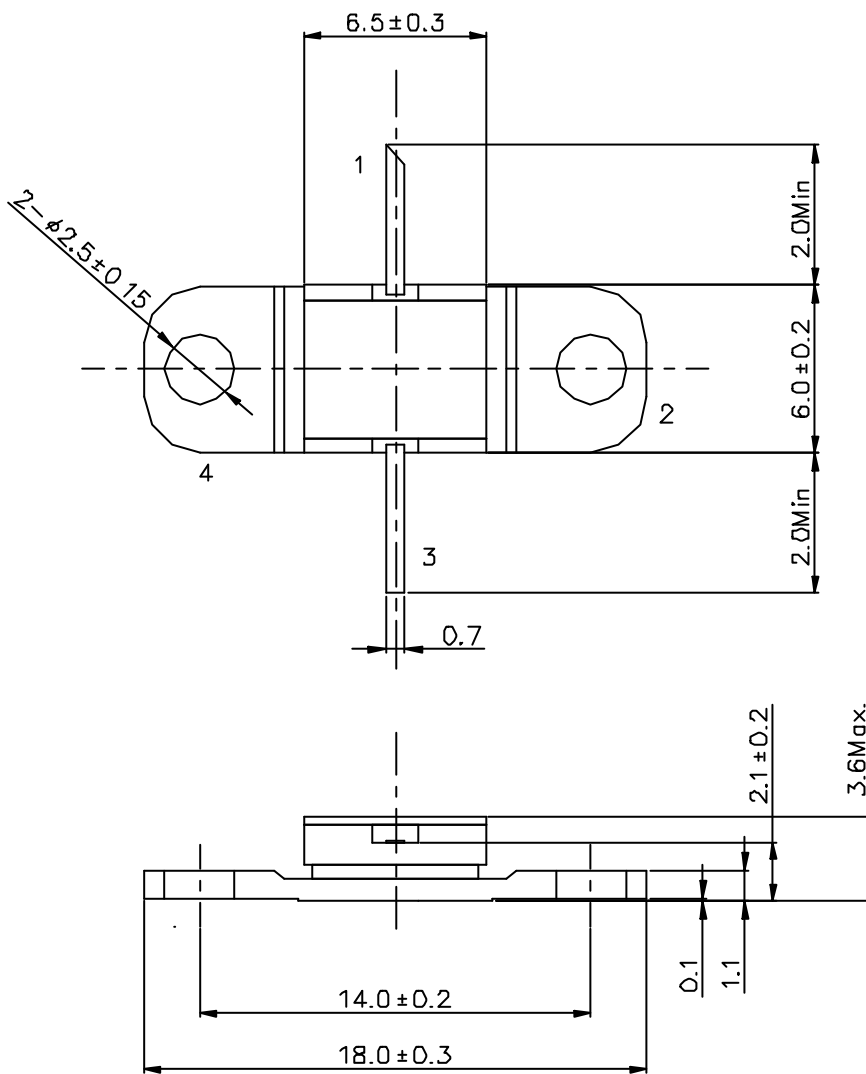

PIN ASSIGNMENT
1 : GATE
2 : SOURCE(Flange)
3 : DRAIN
4 : SOURCE(Flange)

Unit:mm

FLC317MG-4

High Voltage - High Power GaAs FET

For further information please contact :

Eudyna Devices USA Inc.
2355 Zanker Rd.
San Jose, CA 95131-1138, U.S.A.
Phone: (408) 232-9500
FAX: (408) 428-9111
www.fcsi.fujitsu.com

Eudyna Devices Europe Ltd.
Network House
Norreys Drive
Maidenhead, Berkshire SL6 4FJ
Phone: +44 (0) 1628 504800
FAX: +44 (0) 1628 504888

Eudyna Devices Asia Pte. Ltd. Hong Kong Branch

Rm.1101,Ocean Centre, 5 Canton Road, Tsim Sha Tsui Kowloon, Hong kong
Tel: +852-2377-0227
Fax: +852-2377-3921

Eudyna Devices Inc.

1000 Kamisukiahara, showa-cho, Nakakomagun, Yamanashi
409-3883, Japan
(Kokubo Industrial Park)
Tel +81-55-275-4411
Fax +81-55-275-9461

Sales Division

1,Kanai-cho,Sakae-ku,Yokohama,244-0845,Japan
Tel +81-45-853-8156
Fax +81-45-853-8170

CAUTION

Fujitsu Compound Semiconductor Products contain **gallium arsenide (GaAs)** which can be hazardous to the human body and the environment.

For safety, observe the following procedures:

Do not put these products into the mouth.

Do not alter the form of this product into a gas, powder, or liquid through burning, crushing, or chemical processing as these by-products are dangerous to the human body if inhaled, ingested, or swallowed.

Observe government laws and company regulations when discarding this product. This product must be discarded in accordance with methods specified by applicable hazardous waste procedures.

Eudyna