

X, Ku Band Power GaAs FET

FEATURES

- High Output Power: $P_{1dB} = 24.0dBm(Typ.)$
- High Gain: $G_{1dB} = 7.0dB(Typ.)$
- High PAE: $\eta_{add} = 32\%(Typ.)$
- Proven Reliability
- Hermetic Metal/Ceramic Package

DESCRIPTION

The FLK027WG is a power GaAs FET that is designed for general purpose applications in the Ku-Band frequency range as it provides superior power, gain, and efficiency.

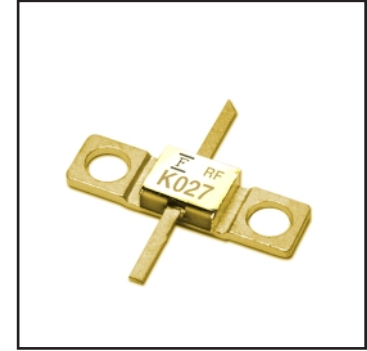

Fujitsu's stringent Quality Assurance Program assures the highest reliability and consistent performance.

ABSOLUTE MAXIMUM RATING (Ambient Temperature Ta=25°C)

Item	Symbol	Condition	Rating	Unit
Drain-Source Voltage	V _{DS}		15	V
Gate-Source Voltage	V _{GS}		-5	V
Total Power Dissipation	P _T	T _C = 25°C	1.875	W
Storage Temperature	T _{stg}		-65 to +175	°C
Channel Temperature	T _{ch}		175	°C

Fujitsu recommends the following conditions for the reliable operation of GaAs FETs:

1. The drain-source operating voltage (V_{DS}) should not exceed 10 volts.
2. The forward and reverse gate currents should not exceed 2.2 and -0.1 mA respectively with gate resistance of 2000Ω.
3. The operating channel temperature (T_{ch}) should not exceed 145°C.

ELECTRICAL CHARACTERISTICS (Ambient Temperature Ta=25°C)

Item	Symbol	Test Conditions	Limit			Unit
			Min.	Typ.	Max.	
Saturated Drain Current	I _{DSS}	V _{DS} = 5V, V _{GS} = 0V	-	100	150	mA
Transconductance	g _m	V _{DS} = 5V, I _{DS} = 65mA	-	50	-	mS
Pinch-off Voltage	V _p	V _{DS} = 5V, I _{DS} = 5mA	-1.0	-2.0	-3.5	V
Gate Source Breakdown Voltage	V _{GSO}	I _{GS} = -5μA	-5	-	-	V
Output Power at 1dB G.C.P.	P _{1dB}	V _{DS} = 10V, I _{DS} = 0.6 I _{DSS} (Typ.), f = 14.5 GHz	23.0	24.0	-	dBm
Power Gain at 1dB G.C.P.	G _{1dB}		6.0	7.0	-	dB
Power-added Efficiency	η _{add}		-	32	-	%
Output Power at 1dB G.C.P.	P _{1dB}	V _{DS} = 10V, I _{DS} = 0.6 I _{DSS} (Typ.), f = 12 GHz	-	24	-	dBm
Power Gain at 1dB G.C.P.	G _{1dB}		-	8	-	dB
Power-added Efficiency	η _{add}		-	34	-	%
Thermal Resistance	R _{th}	Channel to Case	-	40	80	°C/W

CASE STYLE: WG

G.C.P.: Gain Compression Point



POWER DERATING CURVE

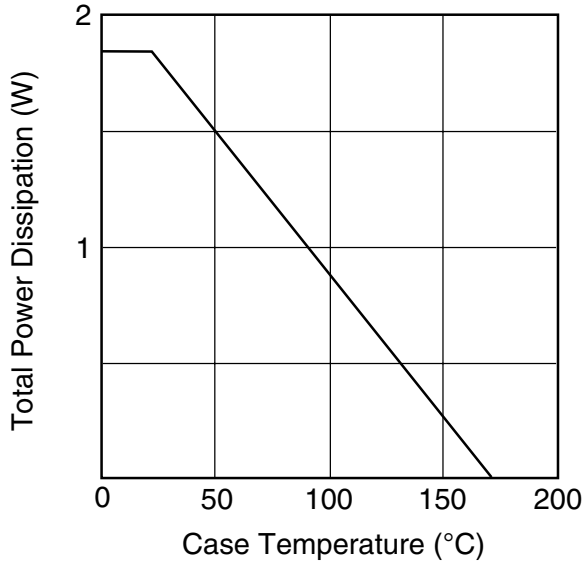

DRAIN CURRENT vs. DRAIN-SOURCE VOLTAGE

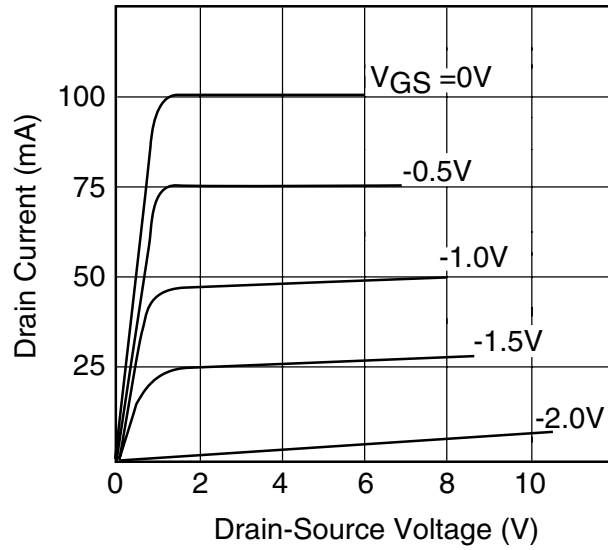

OUTPUT POWER vs. INPUT POWER

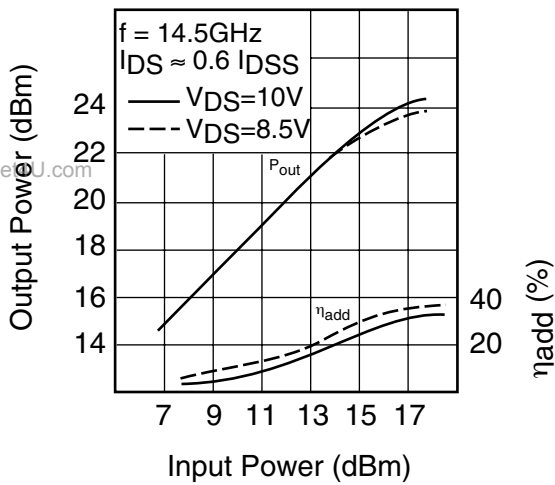

P_{1dB} & η_{add} vs. V_{DS}

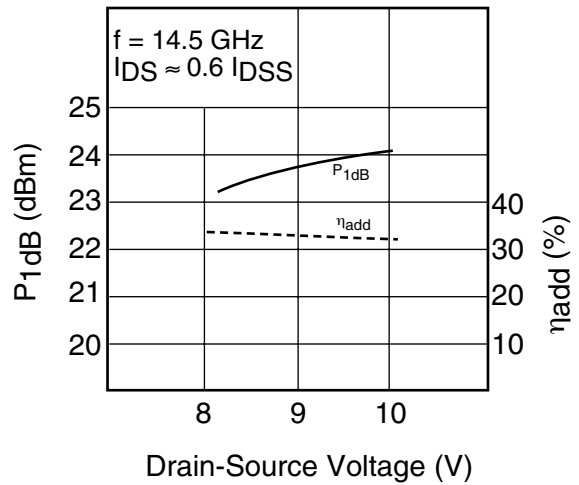

X, Ku Band Power GaAs FET

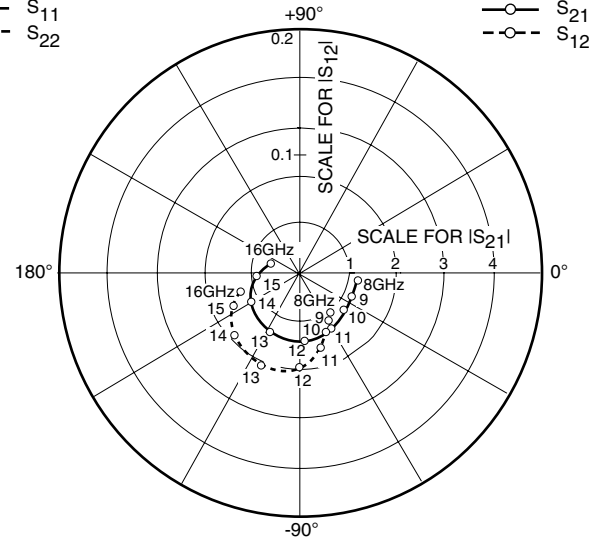
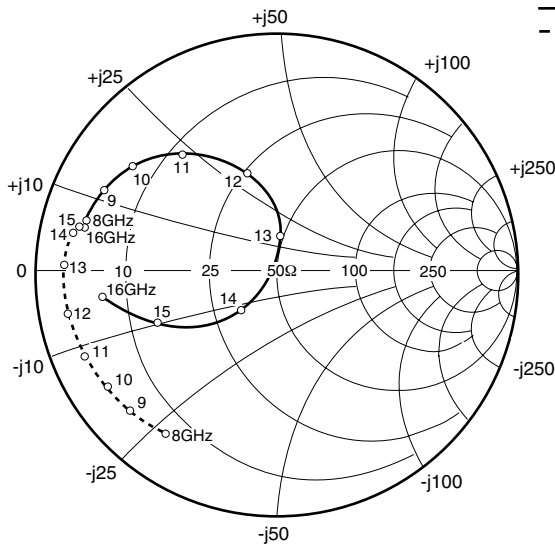

S-PARAMETERS

$V_{DS} = 10V, I_{DS} = 60mA$

FREQUENCY (MHZ)	S11		S21		S12		S22	
	MAG	ANG	MAG	ANG	MAG	ANG	MAG	ANG
500	.985	-31.8	4.381	156.3	.011	67.8	.758	-13.7
1000	.965	-60.1	3.965	134.7	.021	48.5	.748	-27.2
8000	.819	165.4	1.204	-8.3	.041	-54.3	.825	-123.9
8500	.804	159.8	1.177	-16.6	.043	-56.1	.832	-130.0
9000	.787	155.0	1.161	-24.5	.046	-58.6	.838	-135.6
9500	.766	150.1	1.164	-32.1	.049	-61.0	.842	-140.2
10000	.735	144.2	1.197	-40.4	.053	-63.6	.853	-144.8
10500	.689	137.4	1.248	-49.7	.058	-68.7	.864	-149.6
11000	.623	128.7	1.309	-60.3	.065	-74.0	.871	-155.0
11500	.534	118.5	1.364	-72.9	.072	-81.9	.878	-161.4
12000	.423	106.5	1.407	-86.4	.078	-90.5	.885	-167.8
12500	.290	93.9	1.413	-101.2	.082	-101.5	.886	-174.6
13000	.139	82.0	1.380	-116.8	.083	-112.3	.882	-178.7
13500	.036	-123.8	1.304	-133.2	.080	-123.7	.875	-173.0
14000	.223	-131.8	1.190	-149.4	.075	-136.1	.861	-169.2
14500	.395	-144.2	1.041	-164.5	.068	-145.6	.849	-167.8
15000	.542	-155.7	.893	-177.4	.061	-152.8	.842	-167.4
15500	.652	-164.2	.757	-172.1	.054	-156.1	.832	-167.6
16000	.734	-170.9	.655	-163.3	.052	-160.8	.829	-167.3

www.DataSheet4U.com

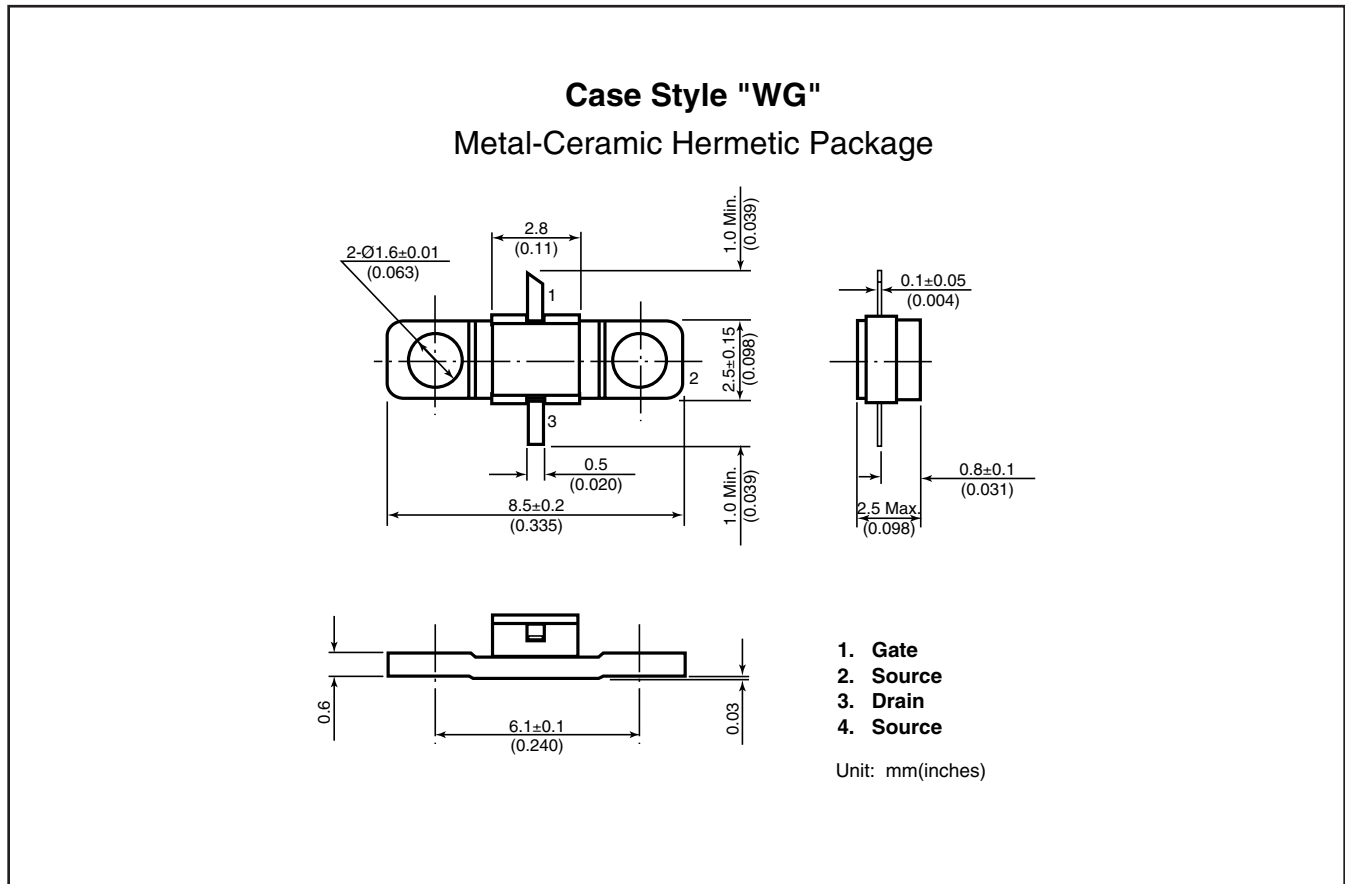

For further information please contact:

FUJITSU COMPOUND SEMICONDUCTOR, INC.

2355 Zanker Rd.
San Jose, CA 95131-1138, U.S.A.
Phone: (408) 232-9500
FAX: (408) 428-9111
www.fcsi.fujitsu.com

FUJITSU MICROELECTRONICS, LTD.

Compound Semiconductor Division
Network House
Norreys Drive
Maidenhead, Berkshire SL6 4FJ
Phone: +44 (0)1628 504800
FAX: +44 (0)1628 504888

CAUTION

Fujitsu Compound Semiconductor Products contain **gallium arsenide (GaAs)** which can be hazardous to the human body and the environment. For safety, observe the following procedures:

- Do not put these products into the mouth.
- Do not alter the form of this product into a gas, powder, or liquid through burning, crushing, or chemical processing as these by-products are dangerous to the human body if inhaled, ingested, or swallowed.
- Observe government laws and company regulations when discarding this product. This product must be discarded in accordance with methods specified by applicable hazardous waste procedures.

Fujitsu Limited reserves the right to change products and specifications without notice. The information does not convey any license under rights of Fujitsu Limited or others.

© 1998 FUJITSU COMPOUND SEMICONDUCTOR, INC.
Printed in U.S.A. FCSI0598M200