

# FLK107MH-14

## X, Ku Band Power GaAs FET

### FEATURES

- High Output Power:  $P_{1dB} = 30.0\text{dBm(Typ.)}$
- High Gain:  $G_{1dB} = 6.5\text{dB(Typ.)}$
- High PAE:  $\eta_{add} = 31\%\text{(Typ.)}$
- Proven Reliability
- Hermetic Metal/Ceramic Package

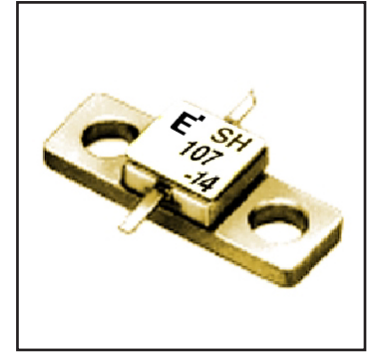

### DESCRIPTION

The FLK102MH-14 is a power GaAs FET that is designed for general purpose applications in the Ku-Band frequency range as it provides superior power, gain, and efficiency.

Eudyna stringent Quality Assurance Program assures the highest reliability and consistent performance.

### ABSOLUTE MAXIMUM RATING (Ambient Temperature $T_a=25^\circ\text{C}$ )

Item	Symbol	Condition	Rating	Unit
Drain-Source Voltage	$V_{DS}$		15	V
Gate-Source Voltage	$V_{GS}$		-5	V
Total Power Dissipation	$P_T$	$T_C = 25^\circ\text{C}$	7.5	W
Storage Temperature	$T_{stg}$		-65 to +175	$^\circ\text{C}$
Channel Temperature	$T_{ch}$		175	$^\circ\text{C}$

Eudyna recommends the following conditions for the reliable operation of GaAs FETs:

1. The drain-source operating voltage ( $V_{DS}$ ) should not exceed 10 volts.
2. The forward and reverse gate currents should not exceed 8.8 and -0.5 mA respectively with gate resistance of  $500\Omega$ .
3. The operating channel temperature ( $T_{ch}$ ) should not exceed  $145^\circ\text{C}$ .

### ELECTRICAL CHARACTERISTICS (Ambient Temperature $T_a=25^\circ\text{C}$ )

Item	Symbol	Test Conditions	Limit			Unit
			Min.	Typ.	Max.	
Saturated Drain Current	$I_{DSS}$	$V_{DS} = 5\text{V}, V_{GS} = 0\text{V}$	-	400	600	mA
Transconductance	$g_m$	$V_{DS} = 5\text{V}, I_{DS} = 250\text{mA}$	-	200	-	mS
Pinch-off Voltage	$V_p$	$V_{DS} = 5\text{V}, I_{DS} = 20\text{mA}$	-1.0	-2.0	-3.5	V
Gate Source Breakdown Voltage	$V_{GSO}$	$I_{GS} = -20\mu\text{A}$	-5	-	-	V
Output Power at 1dB G.C.P.	$P_{1dB}$	$V_{DS} = 10\text{V},$ $I_{DS} = 0.6 I_{DSS} \text{(Typ.)},$ $f = 14.5 \text{GHz}$	29.0	30.0	-	dBm
Power Gain at 1dB G.C.P.	$G_{1dB}$		5.5	6.5	-	dB
Power-added Efficiency	$\eta_{add}$		-	31	-	%
Thermal Resistance	$R_{th}$	Channel to Case	-	15	20	$^\circ\text{C/W}$

CASE STYLE: MH

G.C.P.: Gain Compression Point

# FLK107MH-14

X, Ku Band Power GaAs FET

### POWER DERATING CURVE

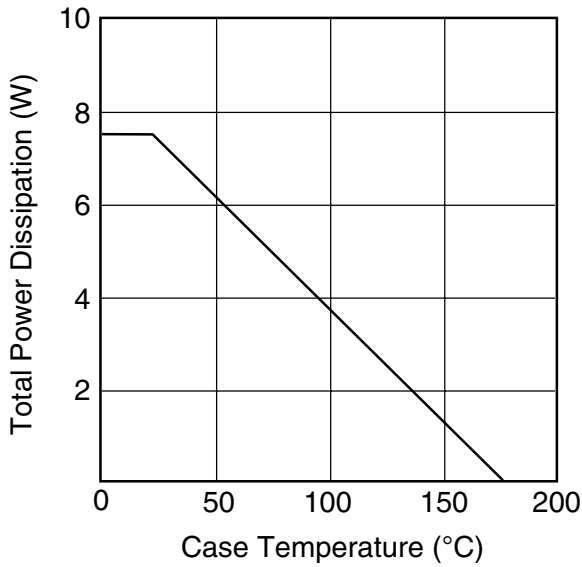

### DRAIN CURRENT vs. DRAIN-SOURCE VOLTAGE

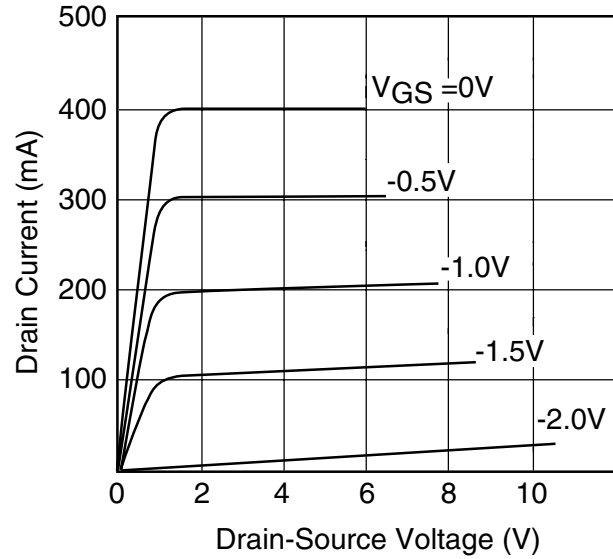

### OUTPUT POWER vs. INPUT POWER

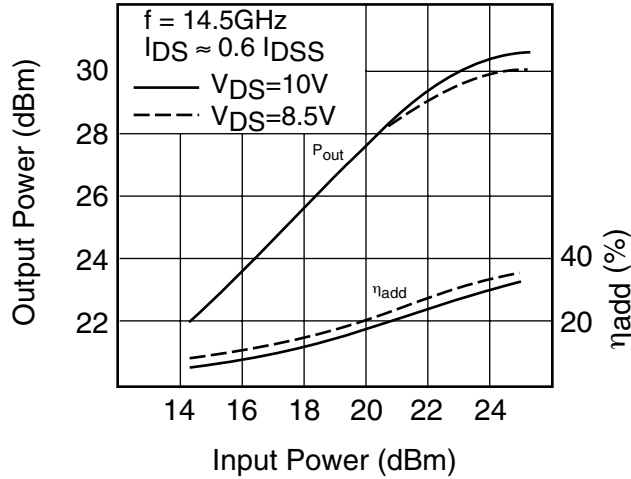

### $P_{1dB}$ & $\eta_{add}$ vs. $V_{DS}$

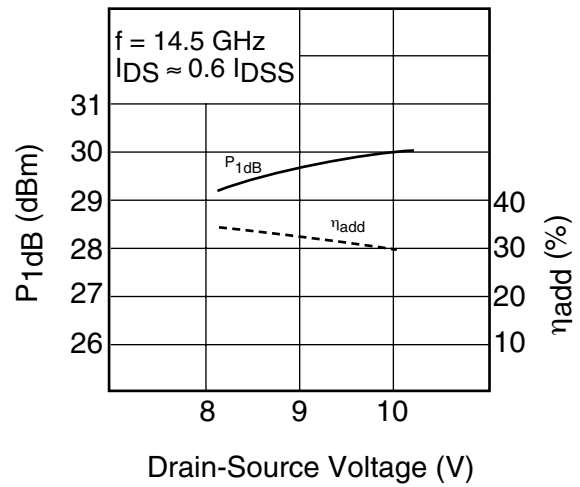

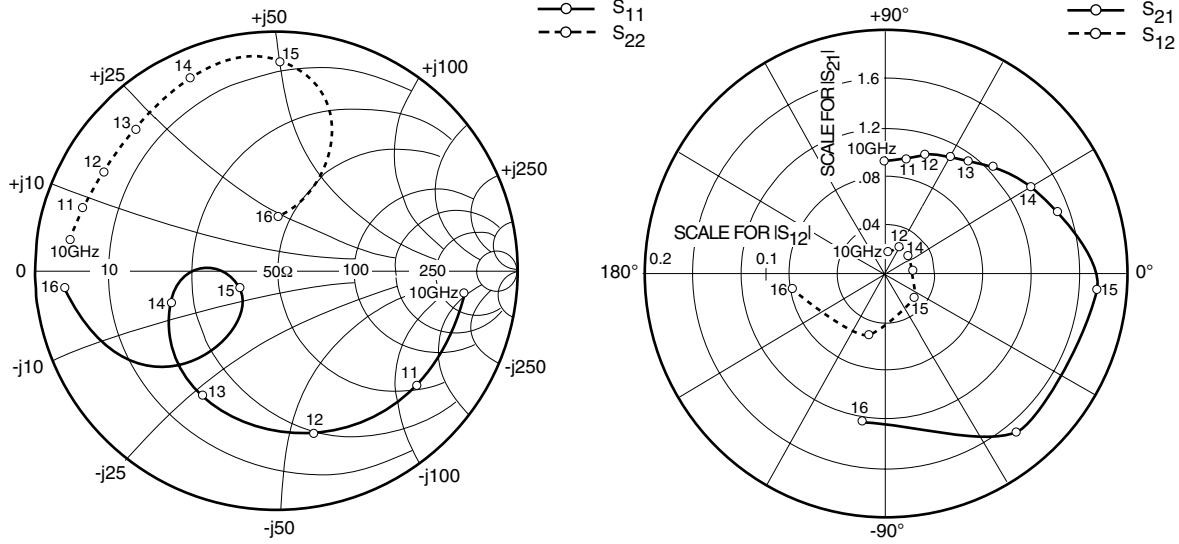

### S-PARAMETERS

$V_{DS} = 10V, I_{DS} = 240mA$

FREQUENCY (MHZ)	S11		S21		S12		S22	
	MAG	ANG	MAG	ANG	MAG	ANG	MAG	ANG
500	.949	-99.8	8.893	131.6	.023	47.7	.275	-58.0
1000	.921	-137.6	5.628	114.8	.028	37.1	.297	-80.9
10000	.783	-6.8	.924	90.5	.039	71.6	.852	171.3
10500	.769	-22.8	.932	85.8	.038	64.4	.857	166.9
11000	.751	-39.7	.959	79.8	.039	67.8	.843	161.7
11500	.730	-57.4	.981	74.2	.043	63.7	.827	156.0
12000	.699	-76.9	1.032	71.9	.049	62.1	.825	149.9
12500	.659	-98.1	1.109	60.8	.044	63.5	.820	142.6
13000	.609	-119.9	1.151	53.5	.045	64.8	.824	134.6
13500	.544	-142.1	1.255	44.7	.045	51.5	.851	125.6
14000	.456	-162.6	1.402	30.5	.046	37.2	.890	113.9
14500	.331	179.3	1.521	19.7	.045	7.2	.913	102.8
15000	.170	-155.0	1.764	-4.8	.063	-39.7	.875	89.2
15500	.528	-132.8	1.697	-50.1	.108	-107.7	.654	69.0
16000	.878	-174.9	1.225	-99.6	.158	-171.2	.226	87.9

# FLK107MH-14

X, Ku Band Power GaAs FET

## Case Style "MH" Metal-Ceramic Hermetic Package

