

### FEATURES

- High Output Power:  $P_{1dB} = 36dBm$  (Typ.)
- High Gain:  $G_{1dB} = 8.0dB$  (Typ.)
- High PAE:  $\eta_{add} = 30%$  (Typ.)
- Low  $IM_3 = -45dBc@P_o = 25dBm$
- Broad Band: 7.1 ~ 7.7GHz
- Impedance Matched  $Z_{in}/Z_{out} = 50\Omega$
- Hermetically Sealed Package

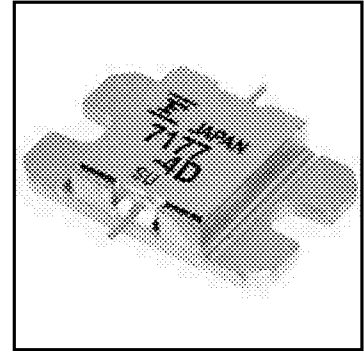

### DESCRIPTION

The FLM7177-4D is a power GaAs FET that is internally matched for standard communication bands to provide optimum power and gain in a 50 ohm system.

Fujitsu's stringent Quality Assurance Program assures the highest reliability and consistent performance.

### ABSOLUTE MAXIMUM RATING (Ambient Temperature $T_a=25^\circ C$ )

Item	Symbol	Condition	Rating	Unit
Drain-Source Voltage	$V_{DS}$		15	V
Gate-Source Voltage	$V_{GS}$		-5	V
Total Power Dissipation	$P_T$	$T_C = 25^\circ C$	25	W
Storage Temperature	$T_{stg}$		-65 to +175	$^\circ C$
Channel Temperature	$T_{ch}$		175	$^\circ C$

Fujitsu recommends the following conditions for the reliable operation of GaAs FETs:

1. The drain-source operating voltage ( $V_{DS}$ ) should not exceed 10 volts.
2. The forward and reverse gate currents should not exceed 8.0 and -2.2 mA respectively with gate resistance of 100 $\Omega$ .

### ELECTRICAL CHARACTERISTICS (Ambient Temperature $T_a=25^\circ C$ )

Item	Symbol	Test Conditions	Limit			Unit
			Min.	Typ.	Max.	
Saturated Drain Current	$I_{DSS}$	$V_{DS} = 5V, V_{GS} = 0V$	-	1800	2700	mA
Transconductance	$g_m$	$V_{DS} = 5V, I_{DS} = 1100mA$	-	1000	-	mS
Pinch-off Voltage	$V_p$	$V_{DS} = 5V, I_{DS} = 90mA$	-1.0	-2.0	-3.5	V
Gate Source Breakdown Voltage	$V_{GSO}$	$I_{GS} = -90\mu A$	-5	-	-	V
Output Power at 1dB G.C.P.	$P_{1dB}$	$V_{DS} = 10V,$ $I_{DS} = 0.6 I_{DSS}$ (Typ.), $f = 7.1 \sim 7.7$ GHz, $Z_S = Z_L = 50$ ohm	35	36	-	dBm
Power Gain at 1dB G.C.P.	$G_{1dB}$		7.0	8.0	-	dB
Drain Current	$I_{dsr}$		-	1100	1300	mA
Power-added Efficiency	$\eta_{add}$		-	30	-	%
Gain Flatness	$\Delta G$		-	-	$\pm 0.6$	dB
3rd Order Intermodulation Distortion	$IM_3$	$f = 7.7$ GHz, $\Delta f = 10$ MHz 2-Tone Test $P_{out} = 25dBm$ S.C.L.	-42	-45	-	dBc
Thermal Resistance	$R_{th}$	Channel to Case	-	5.0	6.0	$^\circ C/W$

CASE STYLE: IB

G.C.P.: Gain Compression Point, S.C.L.: Single Carrier Level

**OUTPUT POWER vs. FREQUENCY**

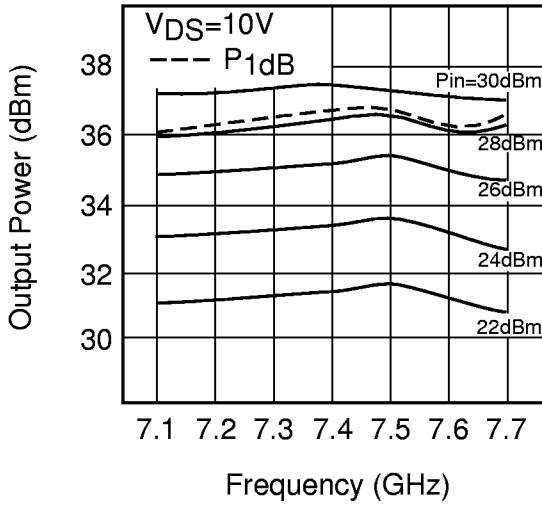

**OUTPUT POWER vs. INPUT POWER**

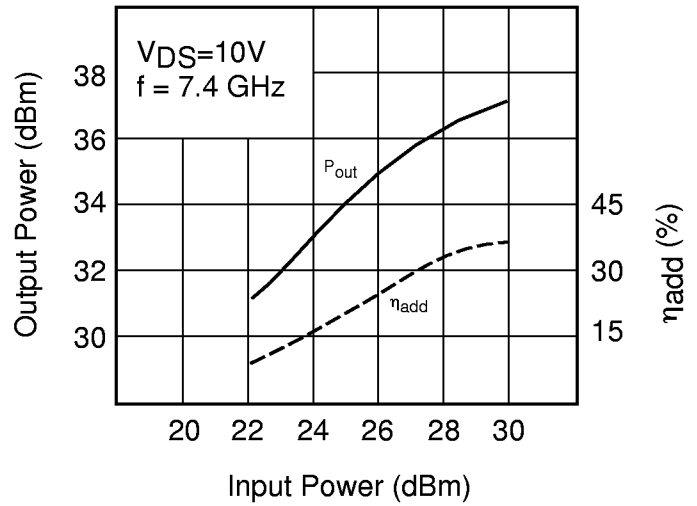

**OUTPUT POWER & IM<sub>3</sub> vs. INPUT POWER**

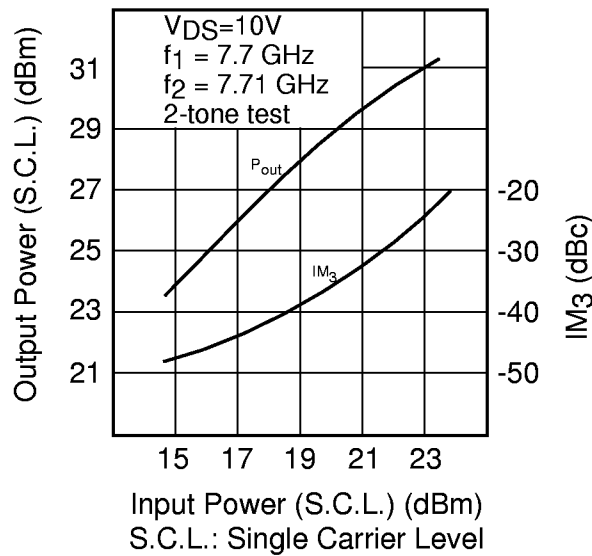

# FLM7177-4D

## Internally Matched Power GaAs FETs

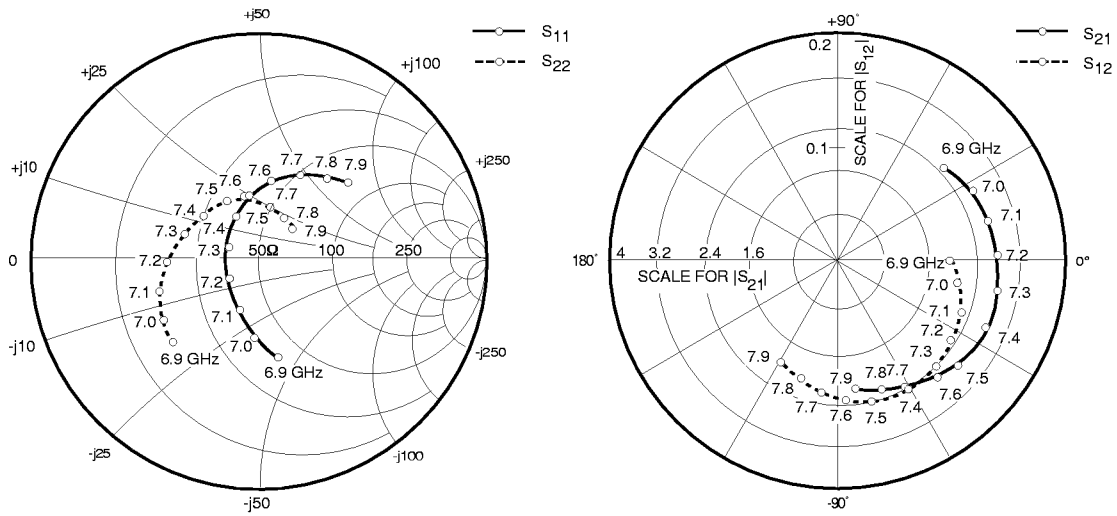

### S-PARAMETERS

$V_{DS} = 10V, I_{DS} = 1100mA$

FREQUENCY (MHZ)	S11		S21		S12		S22	
	MAG	ANG	MAG	ANG	MAG	ANG	MAG	ANG
7000	.33	-89	2.61	27	.10	-10	.53	-147
7100	.24	-110	2.72	15	.11	-20	.50	-159
7200	.16	-145	2.82	2	.11	-33	.45	-176
7300	.14	164	2.80	-10	.12	-48	.41	165
7400	.19	121	2.75	-25	.12	-62	.37	147
7500	.27	93	2.66	-40	.12	-76	.32	123
7600	.33	76	2.54	-52	.11	-87	.28	100
7700	.40	62	2.43	-63	.10	-97	.24	82
7800	.46	50	2.33	-71	.10	-108	.21	64
7900	.52	39	2.27	-83	.10	-119	.21	49

**Case Style "IB"**  
Metal-Ceramic Hermetic Package

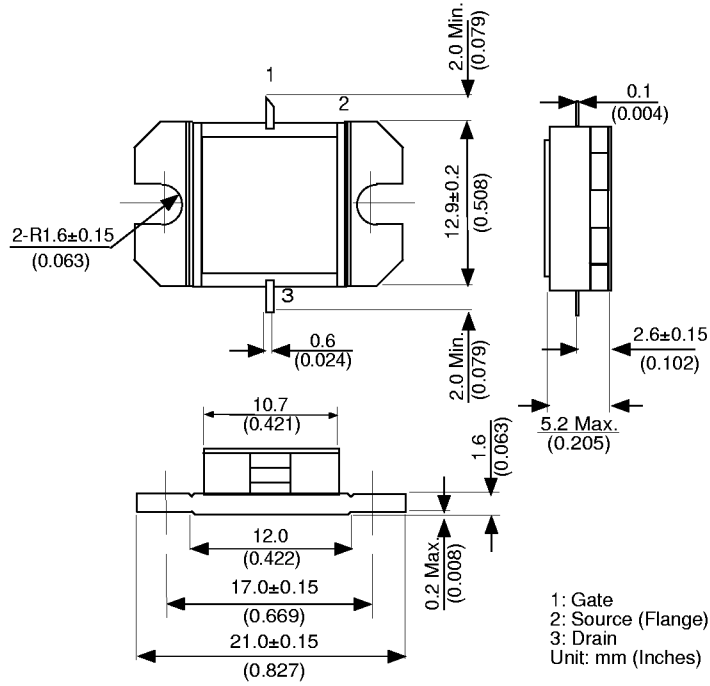

2