

FEATURES

- High Output Power: $P_{1dB} = 39dBm$ (Typ.)
- High Gain: $G_{1dB} = 7.0dB$ (Typ.)
- High PAE: $\eta_{add} = 29%$ (Typ.)
- Low $IM_3 = -45dBc@P_o = 28dBm$
- Broad Band: 7.1 ~ 7.7GHz
- Impedance Matched $Z_{in}/Z_{out} = 50\Omega$
- Hermetically Sealed Package

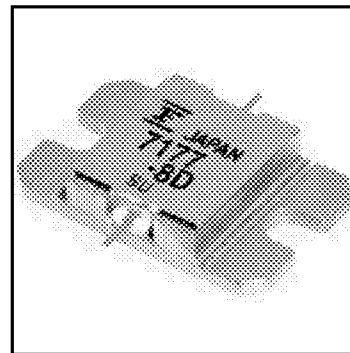

DESCRIPTION

The FLM7177-8D is a power GaAs FET that is internally matched for standard communication bands to provide optimum power and gain in a 50 ohm system.

Fujitsu's stringent Quality Assurance Program assures the highest reliability and consistent performance.

ABSOLUTE MAXIMUM RATING (Ambient Temperature $T_a=25^\circ C$)

Item	Symbol	Condition	Rating	Unit
Drain-Source Voltage	V_{DS}		15	V
Gate-Source Voltage	V_{GS}		-5	V
Total Power Dissipation	P_T	$T_C = 25^\circ C$	42.8	W
Storage Temperature	T_{stg}		-65 to +175	$^\circ C$
Channel Temperature	T_{ch}		175	$^\circ C$

Fujitsu recommends the following conditions for the reliable operation of GaAs FETs:

1. The drain-source operating voltage (V_{DS}) should not exceed 10 volts.
2. The forward and reverse gate currents should not exceed 16 and -4.4 mA respectively with gate resistance of 100 Ω .

ELECTRICAL CHARACTERISTICS (Ambient Temperature $T_a=25^\circ C$)

Item	Symbol	Test Conditions	Limit			Unit
			Min.	Typ.	Max.	
Saturated Drain Current	I_{DSS}	$V_{DS} = 5V, V_{GS} = 0V$	-	3600	5400	mA
Transconductance	g_m	$V_{DS} = 5V, I_{DS} = 2200mA$	-	2000	-	mS
Pinch-off Voltage	V_p	$V_{DS} = 5V, I_{DS} = 180mA$	-1.0	-2.0	-3.5	V
Gate Source Breakdown Voltage	V_{GSO}	$I_{GS} = -180\mu A$	-5	-	-	V
Output Power at 1dB G.C.P.	P_{1dB}	$V_{DS} = 10V,$ $I_{DS} = 0.6 I_{DSS}$ (Typ.), $f = 7.1 \sim 7.7$ GHz, $Z_S = Z_L = 50$ ohm	38	39	-	dBm
Power Gain at 1dB G.C.P.	G_{1dB}		6.0	7.0	-	dB
Drain Current	I_{dsr}		-	2200	2600	mA
Power-added Efficiency	η_{add}		-	29	-	%
Gain Flatness	ΔG		-	-	± 0.6	dB
3rd Order Intermodulation Distortion	IM_3	$f = 7.7$ GHz, $\Delta f = 10$ MHz 2-Tone Test $P_{out} = 28dBm$ S.C.L.	-42	-45	-	dBc
Thermal Resistance	R_{th}	Channel to Case	-	3.0	3.5	$^\circ C/W$

CASE STYLE: IB

G.C.P.: Gain Compression Point, S.C.L.: Single Carrier Level

OUTPUT POWER vs. FREQUENCY

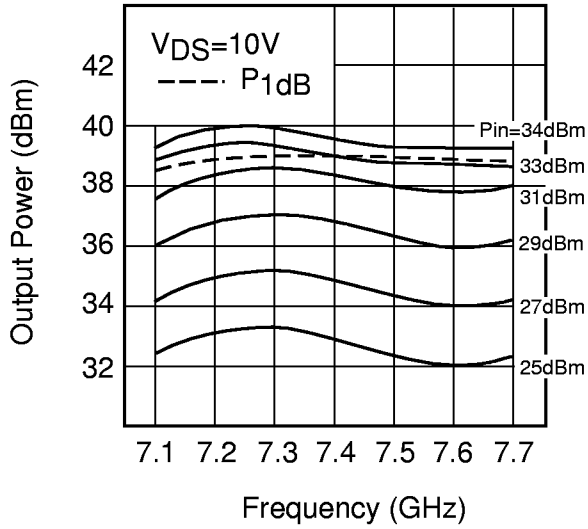

OUTPUT POWER vs. INPUT POWER

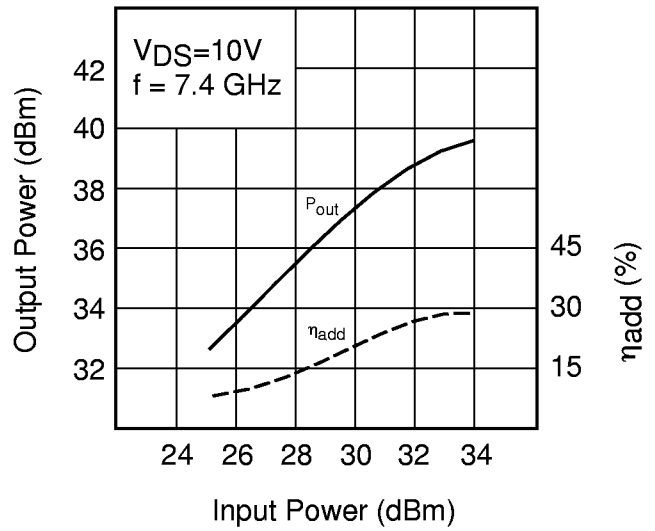

OUTPUT POWER & IM₃ vs. INPUT POWER

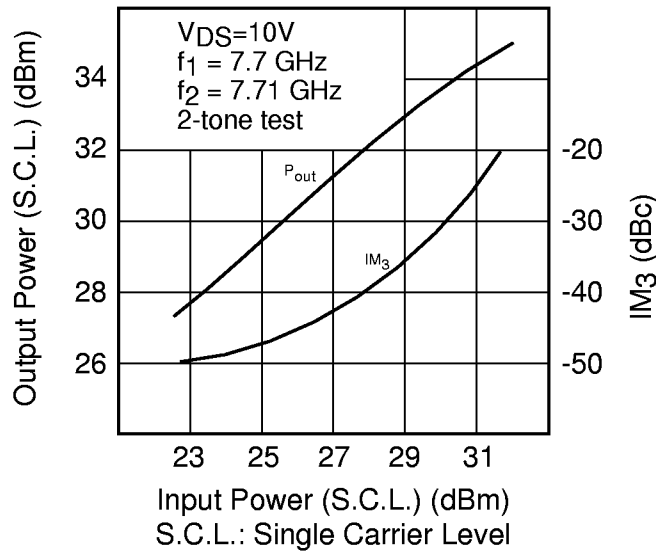

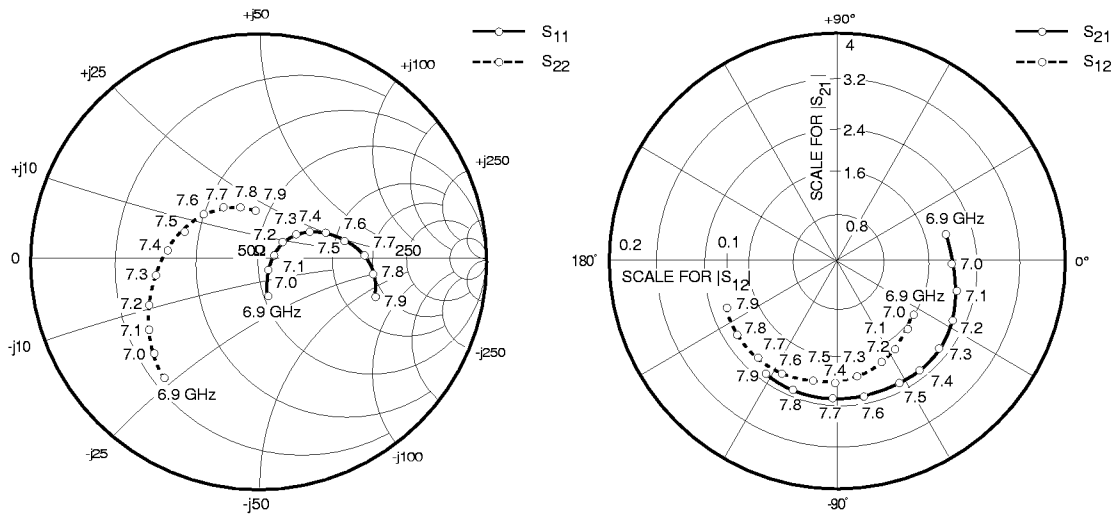

S-PARAMETERS

$V_{DS} = 10V, I_{DS} = 2200mA$

FREQUENCY (MHZ)	S11		S21		S12		S22	
	MAG	ANG	MAG	ANG	MAG	ANG	MAG	ANG
6900	.12	-73	1.97	11	.08	-32	.66	-128
7000	.06	-42	2.01	-1	.08	-45	.63	-139
7100	.07	13	2.11	-14	.08	-54	.60	-147
7200	.13	33	2.19	-25	.08	-68	.55	-157
7300	.19	31	2.22	-38	.09	-79	.50	-172
7400	.27	27	2.26	-53	.10	-92	.47	175
7500	.33	20	2.33	-64	.10	-101	.41	160
7600	.40	10	2.35	-77	.10	-116	.36	146
7700	.46	2	2.29	-92	.10	-131	.30	129
7800	.51	-8	2.31	-106	.10	-143	.27	108
7900	.54	-18	2.27	-112	.10	-157	.23	89

Case Style "IB"
Metal-Ceramic Hermetic Package

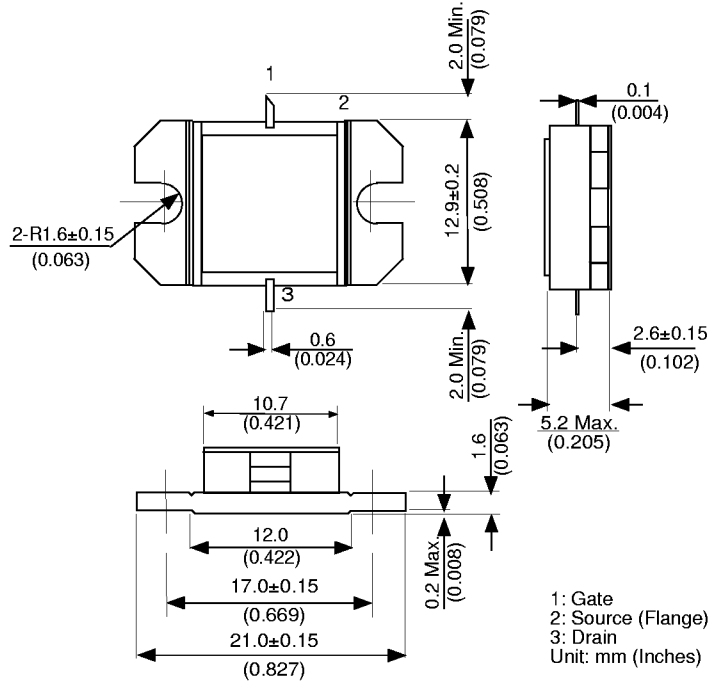

2