

# FLX107MH-12

## X, Ku Band Power GaAs FET

### FEATURES

- High Output Power:  $P_{1dB} = 30.0\text{dBm(Typ.)}$
- High Gain:  $G_{1dB} = 7.5\text{dB(Typ.)}$
- High PAE:  $\eta_{add} = 33\%\text{(Typ.)}$
- Proven Reliability
- Hermetic Metal/Ceramic Package

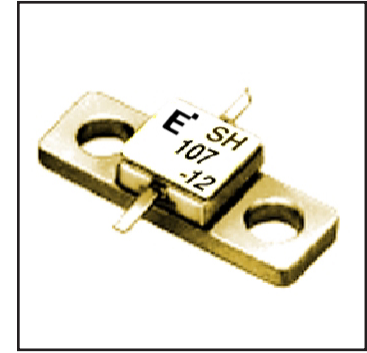

### DESCRIPTION

The FLX107MH-12 is a power GaAs FET that is designed for general purpose applications in the X-Band frequency range as it provides superior power, gain, and efficiency.

Eudyna stringent Quality Assurance Program assures the highest reliability and consistent performance.

### ABSOLUTE MAXIMUM RATING (Ambient Temperature $T_a=25^\circ\text{C}$ )

Item	Symbol	Condition	Rating	Unit
Drain-Source Voltage	$V_{DS}$		15	V
Gate-Source Voltage	$V_{GS}$		-5	V
Total Power Dissipation	$P_T$	$T_C = 25^\circ\text{C}$	7.5	W
Storage Temperature	$T_{stg}$		-65 to +175	$^\circ\text{C}$
Channel Temperature	$T_{ch}$		175	$^\circ\text{C}$

Eudyna recommends the following conditions for the reliable operation of GaAs FETs:

1. The drain-source operating voltage ( $V_{DS}$ ) should not exceed 10 volts.
2. The forward and reverse gate currents should not exceed 8.8 and -0.5 mA respectively with gate resistance of  $500\Omega$ .
3. The operating channel temperature ( $T_{ch}$ ) should not exceed  $145^\circ\text{C}$ .

### ELECTRICAL CHARACTERISTICS (Ambient Temperature $T_a=25^\circ\text{C}$ )

Item	Symbol	Test Conditions	Limit			Unit
			Min.	Typ.	Max.	
Saturated Drain Current	$I_{DSS}$	$V_{DS} = 5\text{V}, V_{GS} = 0\text{V}$	-	400	600	mA
Transconductance	$g_m$	$V_{DS} = 5\text{V}, I_{DS} = 250\text{mA}$	-	200	-	mS
Pinch-off Voltage	$V_p$	$V_{DS} = 5\text{V}, I_{DS} = 20\text{mA}$	-1.0	-2.0	-3.5	V
Gate Source Breakdown Voltage	$V_{GSO}$	$I_{GS} = -20\mu\text{A}$	-5	-	-	V
Output Power at 1dB G.C.P.	$P_{1dB}$	$V_{DS} = 10\text{V},$ $I_{DS} = 0.6 I_{DSS} \text{(Typ.)},$ $f = 12.5 \text{GHz}$	29.0	30.0	-	dBm
Power Gain at 1dB G.C.P.	$G_{1dB}$		6.5	7.5	-	dB
Power-added Efficiency	$\eta_{add}$		-	33	-	%
Thermal Resistance	$R_{th}$	Channel to Case	-	15	20	$^\circ\text{C/W}$

CASE STYLE: MH

G.C.P.: Gain Compression Point

# FLX107MH-12

X, Ku Band Power GaAs FET

### POWER DERATING CURVE

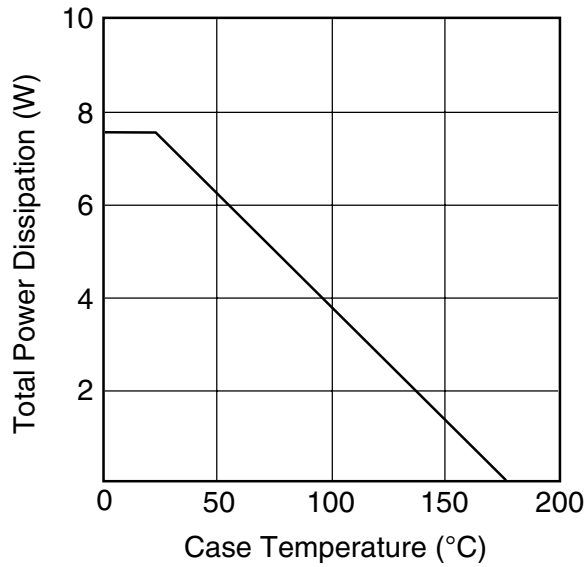

### DRAIN CURRENT vs. DRAIN-SOURCE VOLTAGE

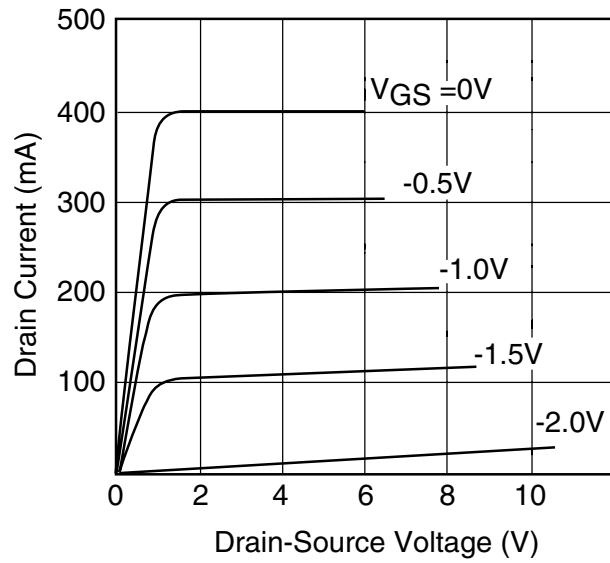

### OUTPUT POWER vs. INPUT POWER

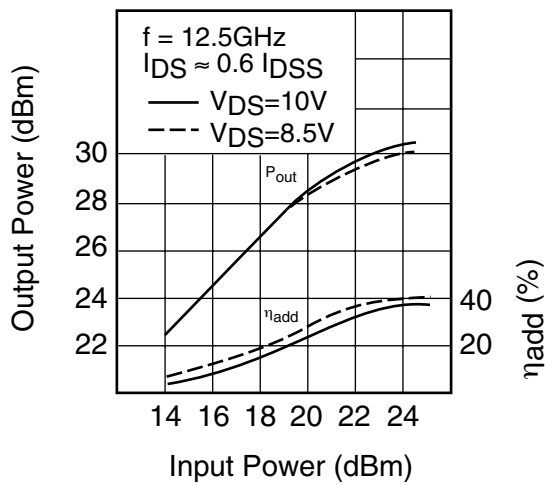

### $P_{1dB}$ & $\eta_{add}$ vs. $V_{DS}$

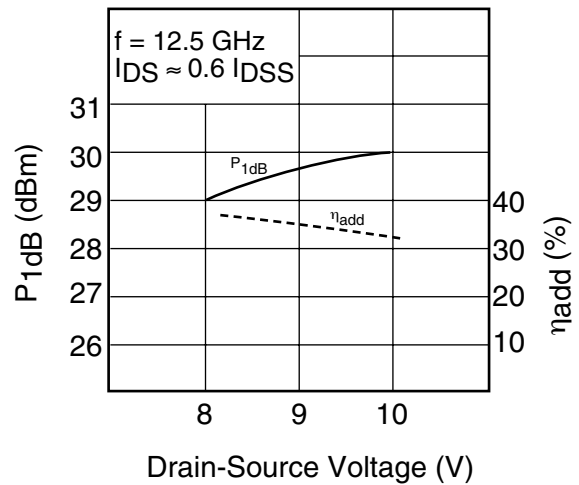

# FLX107MH-12

## X, Ku Band Power GaAs

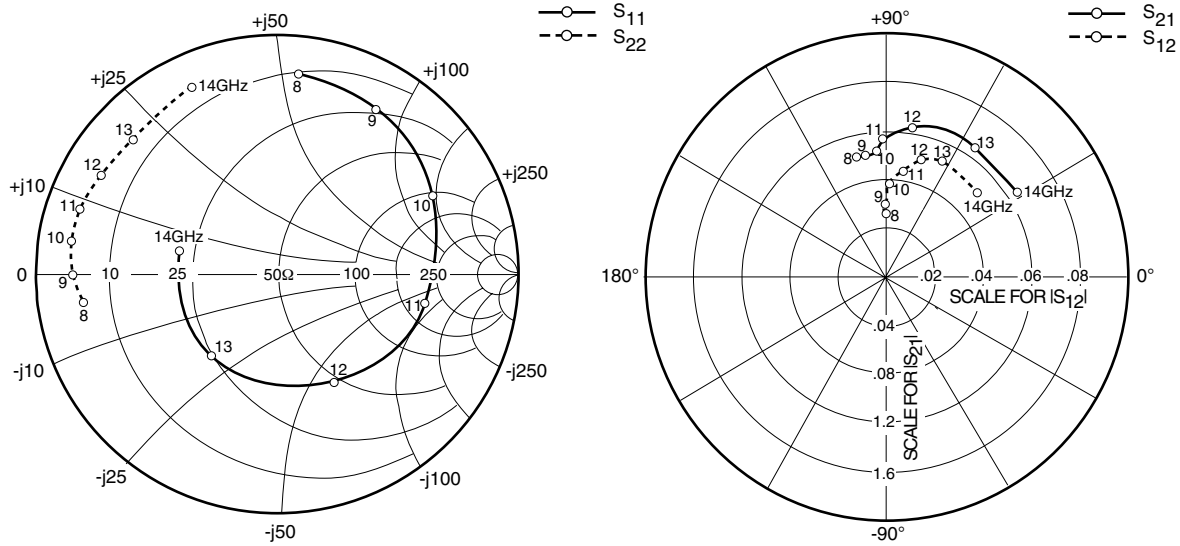

### S-PARAMETERS

$V_{DS} = 10V, I_{DS} = 240mA$

FREQUENCY (MHZ)	S11		S21		S12		S22	
	MAG	ANG	MAG	ANG	MAG	ANG	MAG	ANG
500	.955	-100.1	8.764	132.9	.023	50.0	.281	-52.4
1000	.930	-137.3	5.517	117.2	.028	38.1	.295	-75.4
8000	.841	84.2	1.023	103.8	.026	90.8	.809	-171.9
8500	.820	72.6	1.011	102.2	.027	93.0	.828	-176.1
9000	.794	59.1	1.019	100.6	.029	92.2	.842	-179.9
9500	.766	44.2	1.026	98.8	.035	89.4	.854	175.9
10000	.721	26.8	1.037	95.1	.039	88.6	.867	170.8
10500	.681	8.7	1.014	93.7	.043	81.2	.881	166.6
11000	.627	-11.9	1.138	90.8	.044	81.0	.862	161.3
11500	.576	-34.7	1.222	85.6	.048	76.5	.839	156.5
12000	.516	-62.3	1.245	80.2	.050	74.0	.841	149.9
12500	.468	-94.0	1.311	72.9	.051	70.3	.829	143.6
13000	.438	-127.9	1.294	55.2	.053	64.2	.816	136.5
13500	.422	-161.2	1.293	54.9	.052	56.3	.844	127.8
14000	.412	168.2	1.282	32.7	.051	42.8	.863	114.2

# FLX107MH-12

X, Ku Band Power GaAs FET

## Case Style "MH" Metal-Ceramic Hermetic Package

