

SURFACE MOUNT SCHOTTKY BARRIER RECTIFIER

VOLTAGE 100 Volts CURRENT 1.0 Amperes

FEATURES

- * Ideal for surface mounted applications
- * Low leakage current
- * Metallurgically bonded construction
- * Mounting position: Any
- * Weight: 0.078 gram

MECHANICAL DATA

- * Epoxy: Device has UL flammability classification 94V-O
- * Moisture Sensitivity Level 1

MAXIMUM RATINGS AND ELECTRICAL CHARACTERISTICS

Ratings at 25 °C ambient temperature unless otherwise specified.
Single phase, half wave, 60 Hz, resistive or inductive load.
For capacitive load, derate current by 20%.

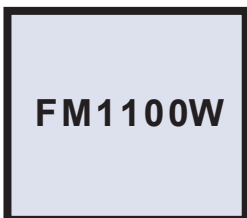

SMX

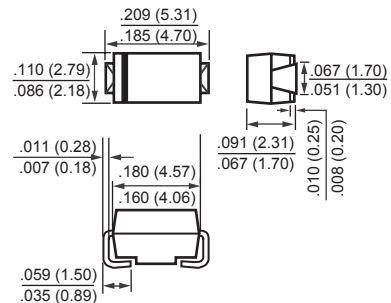

MAXIMUM RATINGS (At TA = 25°C unless otherwise noted)

RATINGS	SYMBOL	FM1100W	UNITS
Maximum Recurrent Peak Reverse Voltage	VRRM	100	Volts
Maximum RMS Voltage	VRMS	70	Volts
Maximum DC Blocking Voltage	VDC	100	Volts
Maximum Average Forward Rectified Current at Derating Lead Temperature	IO	1.0	Amps
Peak Forward Surge Current 8.3 ms single half sine-wave superimposed on rated load (JEDEC method)	IFSM	30	Amps
Typical Current Square Time	I ² T	6.6	A ² S
Typical Thermal Resistance (Note 1)	RθJA	85	°C/W
	RθJL	25	
Typical Junction Capacitance (Note 2)	CJ	30	pF
Operating Temperature Range	TJ	-55 to + 150	°C
Storage Temperature Range	TSTG	-55 to + 150	°C

ELECTRICAL CHARACTERISTICS (At TA = 25°C unless otherwise noted)

CHARACTERISTICS	SYMBOL	FM1100W	UNITS
Maximum Instantaneous Forward Voltage at 1.0A DC	VF	.85	Volts
Maximum Average Reverse Current at Rated DC Blocking Voltage	@TA = 25°C	0.5	mAmps
	@TA = 100°C	20	mAmps

- NOTES : 1. Thermal Resistance (Junction to Ambient).
2. Measured at 1 MHz and applied reverse voltage of 4.0 volts.
3. P.C.B Mounted with 0.4X0.4" (10.0X10.0mm²) copper pad area.

RATING AND CHARACTERISTIC CURVES (FM1100W)

FIG. 1 - TYPICAL FORWARD CURRENT DERATING CURVE

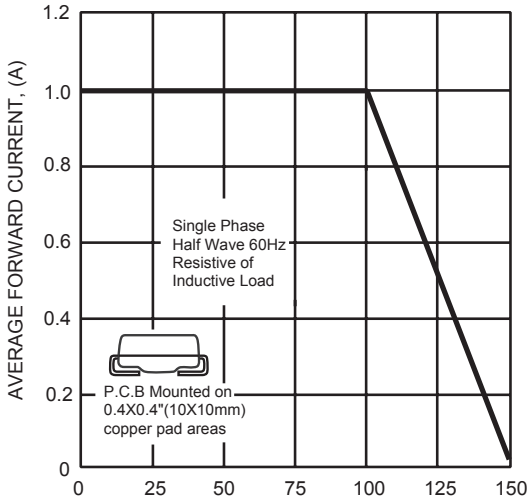

FIG.2 TYPICAL REVERSE CHARACTERISTICS

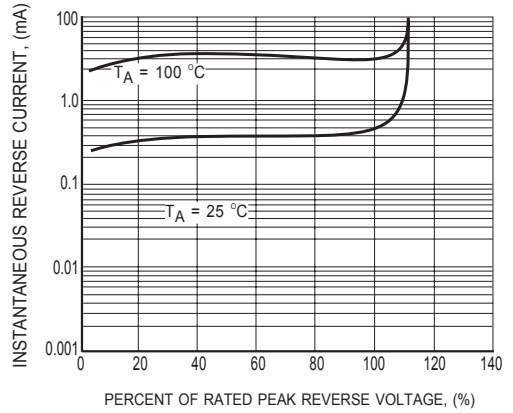

FIG.3 TYPICAL INSTANTANEOUS FORWARD CHARACTERISTICS

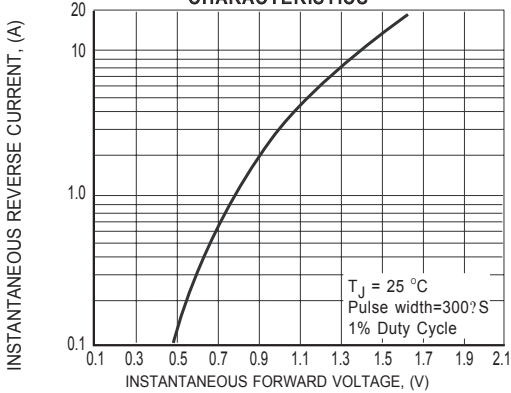

FIG. 4 - TYPICAL JUNCTION CAPACITANCE

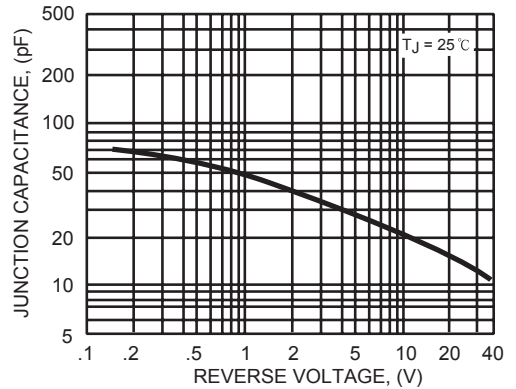
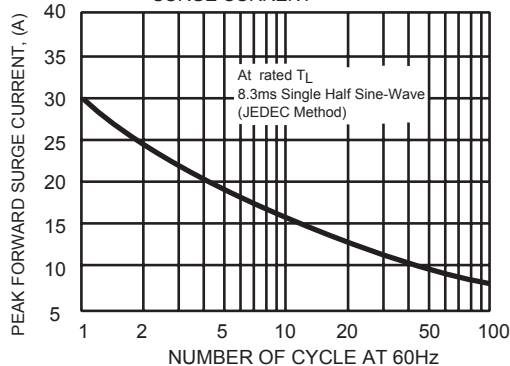

FIG. 5 - MAXIMUM NON-REPETITIVE FORWARD SURGE CURRENT





Attachment information about FM1XX

1. Internal Circuit



2. Marking on the body

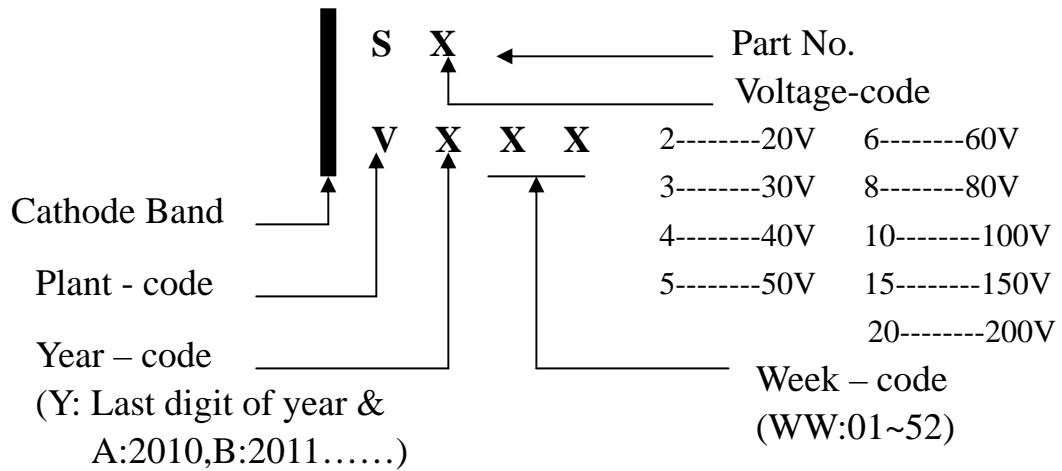



Attachment information about FM1XX

4. Items marked on the reel box and carton

4.1 On the reel (for -T & -W)

CUSTOMER

TYPE

QUANTITY

LOT NO.

Q.A.

REMARK

4.2 On the box (for -T & -W)

TYPE

QUANTITY

LOT NO.

Q.A.

4.3 On the carton

CUSTOMER

TYPE

QUANTITY

LOT NO.

REMARK

Mounting Pad Layout

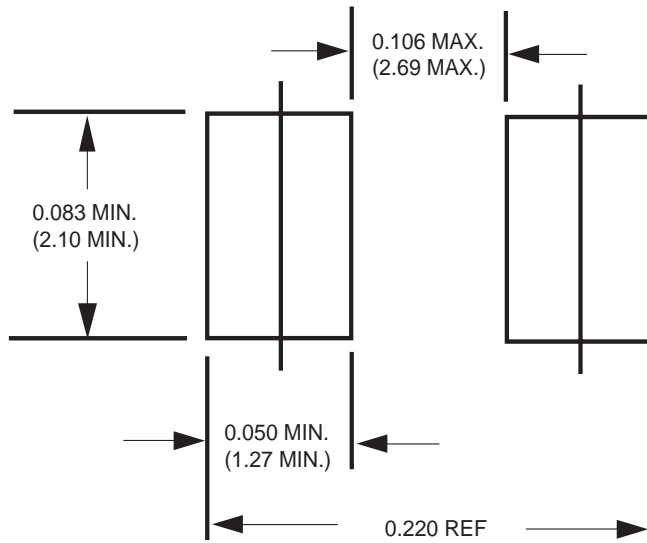

Dimensions in inches and (millimeters)

PACKAGING OF DIODE AND BRIDGE RECTIFIERS

REEL PACK

PACKAGE	PACKING CODE	EA PER REEL	COMPONENT SPACE(mm)	TAPE SPACE (mm)	REEL DIA (mm)	CARTON SIZE (mm)	EA PER CARTON	GROSS WEIGHT(Kg)
SMX	-T	1,500	---	---	180	390*205*310	48,000	---
SMX	-W	5,000	---	---	330	355*360*350	80,000	15.20

1. REEL

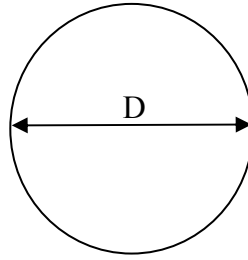

Packing Code	D (mm)
-T	180
-W	330

2. CARTON

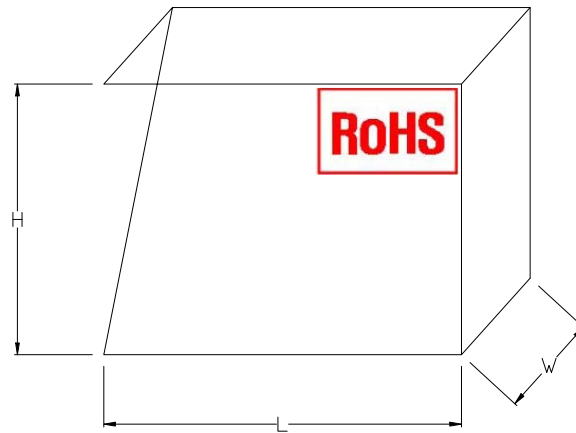

Packing Code	L (mm)	W (mm)	H (mm)
-T	390	205	310
-W	355	360	350

DISCLAIMER NOTICE

Rectron Inc reserves the right to make changes without notice to any product specification herein, to make corrections, modifications, enhancements or other changes. Rectron Inc or anyone on its behalf assumes no responsibility or liability for any errors or inaccuracies. Data sheet specifications and its information contained are intended to provide a product description only. "Typical" parameters which may be included on RECTRON data sheets and/ or specifications can and do vary in different applications and actual performance may vary over time. Rectron Inc does not assume any liability arising out of the application or use of any product or circuit.

Rectron products are not designed, intended or authorized for use in medical, life-saving implant or other applications intended for life-sustaining or other related applications where a failure or malfunction of component or circuitry may directly or indirectly cause injury or threaten a life without expressed written approval of Rectron Inc. Customers using or selling Rectron components for use in such applications do so at their own risk and shall agree to fully indemnify Rectron Inc and its subsidiaries harmless against all claims, damages and expenditures.