

FM1L40-MS THRU FM1L60-MS

List

List..... 1

Package outline..... 2

Features..... 2

Mechanical data..... 2

Maximum ratings 2

Rating and characteristic curves..... 3

Pinning information..... 4

Marking..... 4

Suggested solder pad layout..... 4

Packing information..... 5

Reel packing..... 6

Suggested thermal profiles for soldering processes..... 6

High reliability test capabilities..... 7

FM1L40-MS THRU FM1L60-MS

1.0A Low VF Surface Mount Schottky Barrier Rectifiers - 40V-60V

Features

- High current density schottky.
- Low profile surface mounted application in order to optimize board space.
- Tiny plastic SMD package.
- Low power loss, high efficiency.
- High current capability, low forward voltage drop.
- High surge capability.
- Lead-free parts meet RoHS requirements.
- Suffix "-H" indicates Halogen free parts, ex. FM1L40-MS-H.

Mechanical data

- Epoxy : UL94-V0 rated flame retardant
- Case : Molded plastic, SOD-123S/MINI SMA
- Terminals :Plated terminals, solderable per MIL-STD-750, Method 2026
- Polarity : Indicated by cathode band
- Mounting Position : Any
- Weight : Approximated 0.0155 gram

Package outline

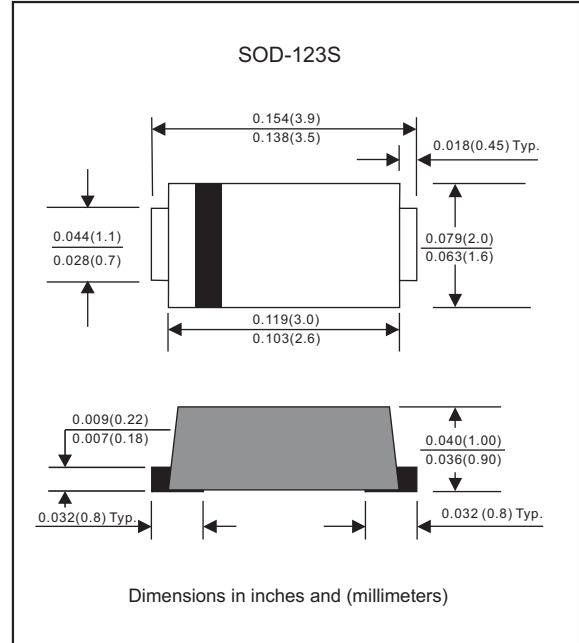

Maximum ratings (AT T_A=25°C unless otherwise noted)

PARAMETER	SYMBOLS	FM1L40-MS	FM1L45-MS	FM1L60-MS	UNITS
Maximum repetitive peak reverse voltage	V _{RRM}	40	45	60	Volts
Maximum RMS voltage	V _{RMS}	28	31.5	42	Volts
Maximum continuous reverse voltage	V _R	40	45	60	Volts
Maximum average forward rectified current	I _o	1.0			Amps
Non-repetitive peak forward surge current 1.0ms square-wave	I _{FSM}	30			Amps
Operating junction temperature range	T _J	-55 to +125		-55 to +150	°C
Storage temperature range	T _{STG}	-65 to +175			°C

Electrical characteristics (AT T_A=25°C unless otherwise noted)

PARAMETER	SYMBOLS	FM1L40-MS	FM1L45-MS	FM1L60-MS	UNITS
Maximum instantaneous forward voltage at I _F =1.0A	V _F	0.45	0.45	0.55	Volts
Maximum reverse leakage current at rated V _R	I _R	0.5 10			mA mA

Thermal characteristics

PARAMETER	SYMBOLS	FM1L40-MS	FM1L45-MS	FM1L60-MS	UNITS
Typical thermal resistance junction to ambient (note 1)	R _{θJA}	80			°C / W
Typical thermal resistance junction to case (note 1)	R _{θJC}	40			°C / W

Note 1: Mounted on FR-4 PCB Copper, minimum recommended pad layout.

Rating and characteristic curves (FM1L40-MS THRU FM1L60-MS)

FIG.1-TYPICAL FORWARD CURRENT DERATING CURVE

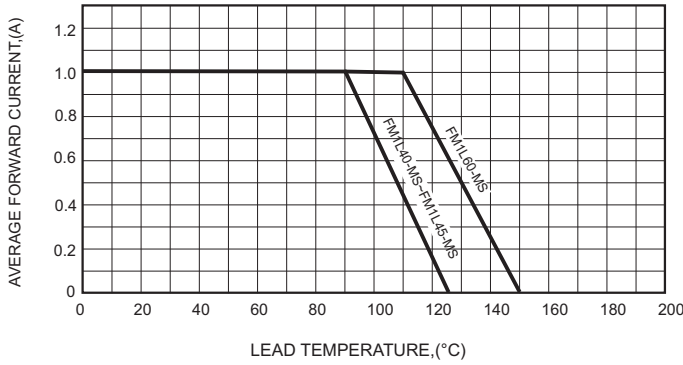

FIG.2-TYPICAL FORWARD CHARACTERISTICS

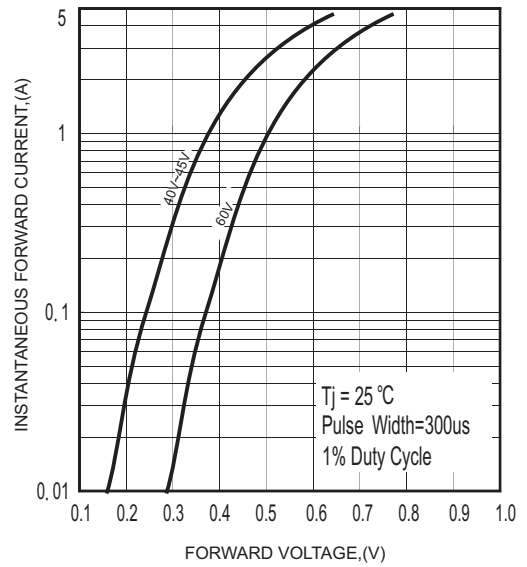

FIG.3-MAXIMUM NON-REPETITIVE FORWARD SURGE CURRENT

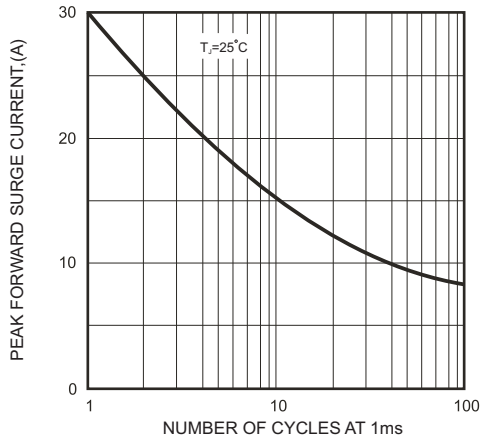
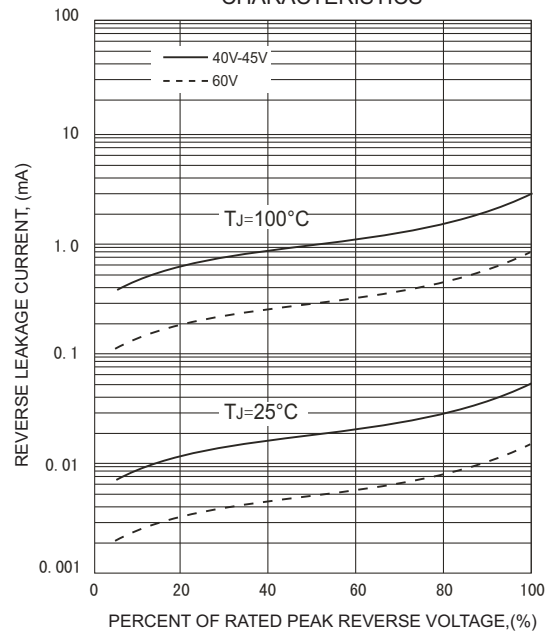



FIG.4 - TYPICAL REVERSE CHARACTERISTICS



FM1L40-MS THRU FM1L60-MS

Pinning information

Pin	Simplified outline	Symbol
Pin1 cathode Pin2 anode		

Marking

Type number	Marking code
FM1L40-MS	1LC
FM1L45-MS	1LP
FM1L60-MS	1LE

Suggested solder pad layout

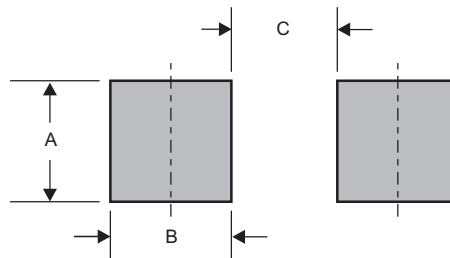

Dimensions in inches and (millimeters)

PACKAGE	A	B	C
SOD-123S	0.044 (1.10)	0.040 (1.00)	0.079 (2.00)

FM1L40-MS THRU FM1L60-MS

Packing information

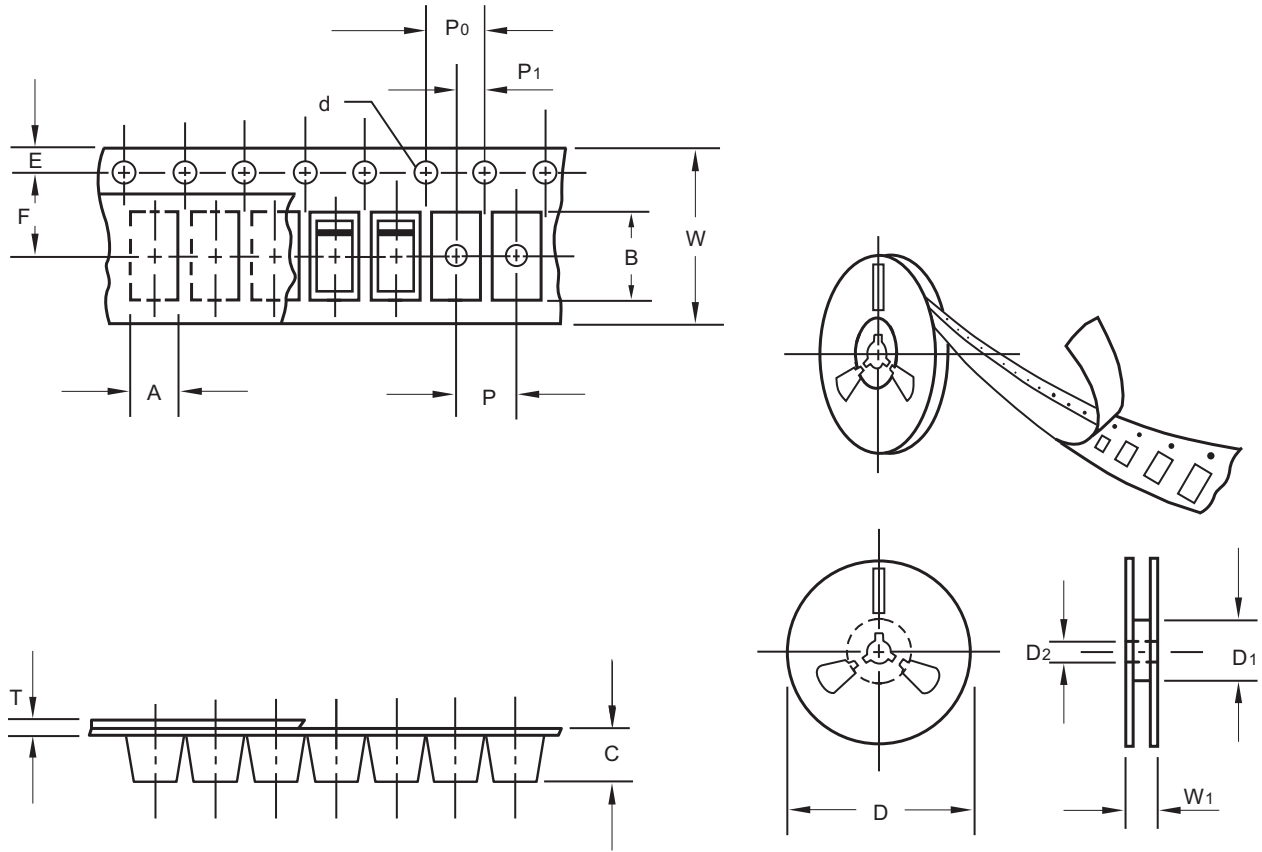

unit:mm

Item	Symbol	Tolerance	SOD-123S
Carrier width	A	0.1	2.00
Carrier length	B	0.1	3.85
Carrier depth	C	0.1	1.10
Sprocket hole	d	0.1	1.50
13" Reel outside diameter	D	2.0	-
13" Reel inner diameter	D1	min	-
7" Reel outside diameter	D	2.0	178.00
7" Reel inner diameter	D1	min	62.00
Feed hole diameter	D2	0.5	13.00
Sprocket hole position	E	0.1	1.75
Punch hole position	F	0.1	3.50
Punch hole pitch	P	0.1	4.00
Sprocket hole pitch	P0	0.1	4.00
Embossment center	P1	0.1	2.00
Overall tape thickness	T	0.1	0.23
Tape width	W	0.3	8.00
Reel width	W1	1.0	11.40

Note: Devices are packed in accordance with EIA standard RS-481-A and specifications listed above.

FM1L40-MS THRU FM1L60-MS

Reel packing

PACKAGE	REEL SIZE	REEL (pcs)	COMPONENT SPACING (m/m)	BOX (pcs)	INNER BOX (m/m)	REEL DIA, (m/m)	CARTON SIZE (m/m)	CARTON (pcs)	APPROX. GROSS WEIGHT (kg)
SOD-123S	7"	3,000	4.0	30,000	183*123*183	178	382*257*387	240,000	9.5

Suggested thermal profiles for soldering processes

- 1.Storage environment: Temperature=5°C~40°C Humidity=55%±25%
- 2.Reflow soldering of surface-mount devices

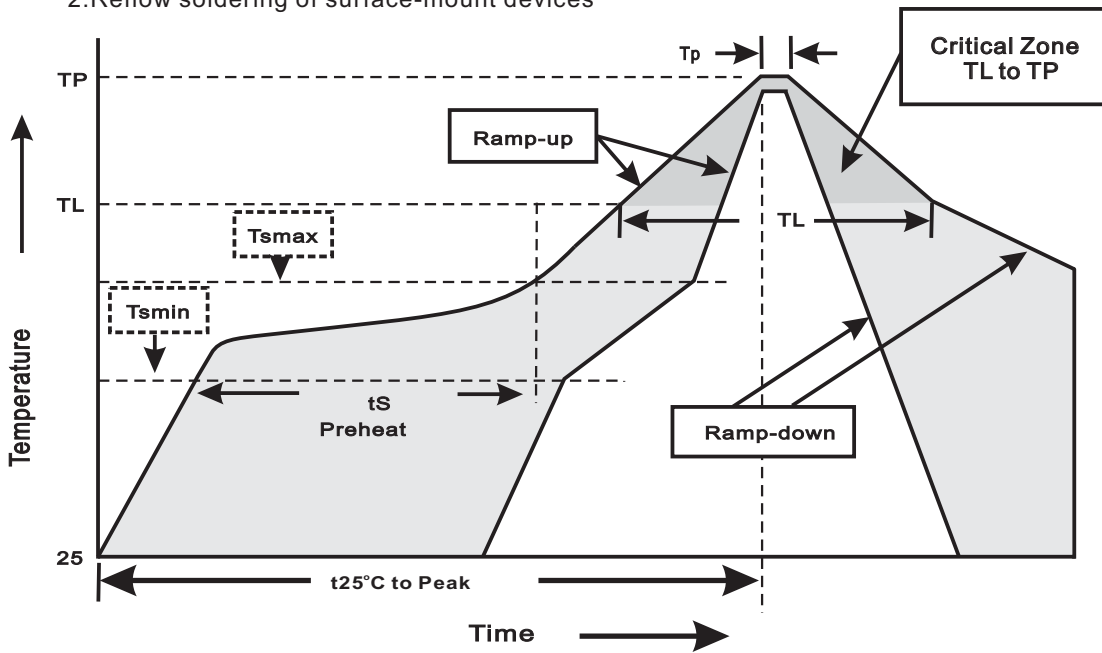

3.Reflow soldering

Profile Feature	Soldering Condition
Average ramp-up rate(T _L to T _P)	<3°C/sec
Preheat -Temperature Min(T _{smmin}) -Temperature Max(T _{smmax}) -Time(min to max)(t _s)	150°C 200°C 60~120sec
T _{smmax} to T _L -Ramp-upRate	<3°C/sec
Time maintained above: -Temperature(T _L) -Time(t _L)	217°C 60~260sec
Peak Temperature(T _P)	255°C-0/+5°C
Time within 5°C of actual Peak Temperature(t _P)	10~30sec
Ramp-down Rate	<6°C/sec
Time 25°C to Peak Temperature	<6minutes

FM1L40-MS THRU FM1L60-MS**High reliability test capabilities**

Item Test	Conditions	Reference
1. Solder Resistance	at 260±5°C for 10±2sec.	MIL-STD-750D METHOD-2031
2. Solderability	at 245±5°C for 5 sec.	MIL-STD-202F METHOD-208
3. High Temperature Reverse Bias	$V_R=80\%$ rate at $T_J=125^\circ\text{C}$ for 168 hrs.	MIL-STD-750D METHOD-1038
4. Forward Operation Life	Rated average rectifier current at $T_A=25^\circ\text{C}$ for 500hrs.	MIL-STD-750D METHOD-1027
5. Intermittent Operation Life	$T_A = 25^\circ\text{C}$, $I_F = I_o$ On state: power on for 5 min. off state: power off for 5 min. on and off for 500 cycles.	MIL-STD-750D METHOD-1036
6. Pressure Cooker	15P _{SIG} at $T_A=121^\circ\text{C}$ for 4 hrs.	JESD22-A102
7. Temperature Cycling	-55°C to +125°C dwelled for 30 min. and transferred for 5min. total 10 cycles.	MIL-STD-750D METHOD-1051
8. Forward Surge	1.0ms square-wave , one surge.	MIL-STD-750D METHOD-4066-2
9. Humidity	at $T_A=85^\circ\text{C}$, RH=85% for 1000hrs.	MIL-STD-750D METHOD-1021
10. High Temperature Storage Life	at 175°C for 1000 hrs.	MIL-STD-750D METHOD-1031