

# FM220-BS THRU FM2200-BS

## List

List.....	1
Package outline.....	2
Features.....	2
Mechanical data.....	2
Maximum ratings and Electrical characteristics .....	2
Rating and characteristic curves.....	3
Pinning information.....	4
Marking.....	4
Suggested solder pad layout.....	4
Packing information.....	5
Reel packing.....	6
Suggested thermal profiles for soldering processes.....	6
High reliability test capabilities.....	7

# FM220-BS THRU FM2200-BS

## 2.0A Surface Mount Schottky Barrier Rectifiers - 20V-200V

### Features

- Batch process design, excellent power dissipation offers better reverse leakage current and thermal resistance.
- Low profile surface mounted application in order to optimize board space.
- Low power loss, high efficiency.
- High current capability, low forward voltage drop.
- High surge capability.
- Guardring for overvoltage protection.
- Ultra high-speed switching.
- Silicon epitaxial planar chip, metal silicon junction.
- Lead-free parts meet environmental standards of MIL-STD-19500 /228
- Suffix "-H" indicates Halogen free parts, ex. FM220-BS-H.

### Mechanical data

- Epoxy:UL94-V0 rated flame retardant
- Case : Molded plastic, DO-214AA/SMB-S
- Terminals : Solder plated, solderable per MIL-STD-750, Method 2026
- Polarity : Indicated by cathode band
- Mounting Position : Any
- Weight : Approximated 0.072 gram

### Package outline

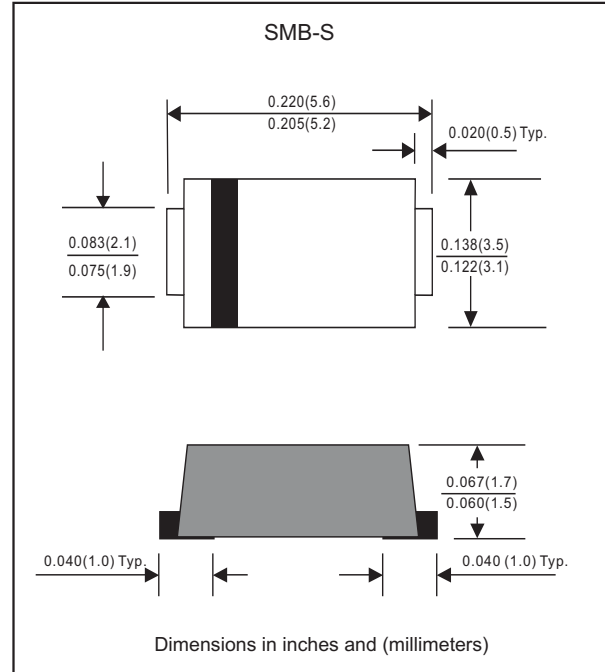

### Maximum ratings and Electrical characteristics (AT $T_A=25^{\circ}\text{C}$ unless otherwise noted)

PARAMETER	CONDITIONS	Symbol	MIN.	TYP.	MAX.	UNIT
Forward rectified current	See Fig.1	$I_o$			2.0	A
Forward surge current	8.3ms single half sine-wave (JEDEC methode)	$I_{FSM}$			50	A
Reverse current	$V_R = V_{RRM} \quad T_J = 25^{\circ}\text{C}$	$I_R$			0.5	mA
	$V_R = V_{RRM} \quad T_J = 100^{\circ}\text{C}$				10	
Thermal resistance	Junction to ambient	$R_{\theta JA}$		60		$^{\circ}\text{C/W}$
	Junction to case	$R_{\theta JC}$		30		$^{\circ}\text{C/W}$
Diode junction capacitance	f=1MHz and applied 4V DC reverse voltage	$C_J$		160		pF
Storage temperature		$T_{STG}$	-65		+175	$^{\circ}\text{C}$

SYMBOLS	$V_{RRM}^{*1}$ (V)	$V_{RMS}^{*2}$ (V)	$V_R^{*3}$ (V)	$V_F^{*4}$ (V)	Operating temperature $T_J$ ( $^{\circ}\text{C}$ )
FM220-BS	20	14	20	0.50	-55 to +125
FM230-BS	30	21	30		
FM240-BS	40	28	40		
FM250-BS	50	35	50	0.70	-55 to +150
FM260-BS	60	42	60		
FM280-BS	80	56	80	0.85	
FM2100-BS	100	70	100		
FM2150-BS	150	105	150	0.90	
FM2200-BS	200	140	200	0.92	

- \*1 Repetitive peak reverse voltage
- \*2 RMS voltage
- \*3 Continuous reverse voltage
- \*4 Maximum forward voltage@ $I_F=2.0A$

## Rating and characteristic curves (FM220-BS THRU FM2200-BS)

FIG.1-TYPICAL FORWARD CURRENT DERATING CURVE

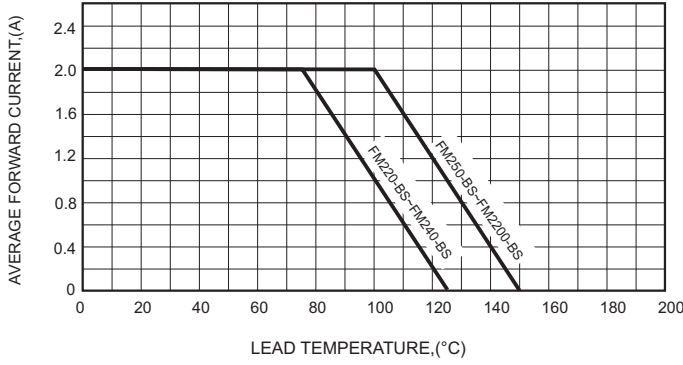

FIG.2-TYPICAL FORWARD CHARACTERISTICS

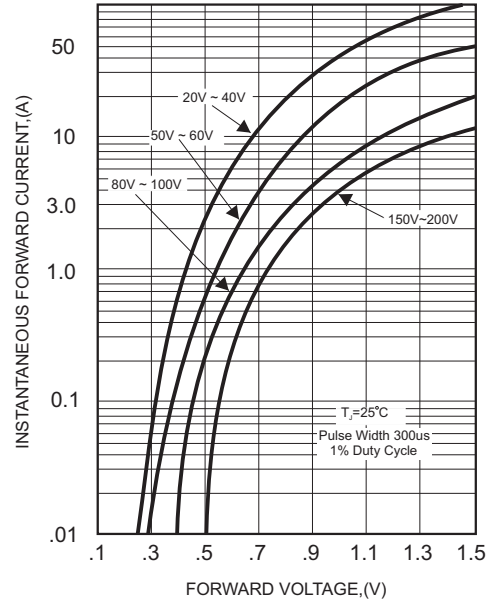

FIG.3-MAXIMUM NON-REPETITIVE FORWARD SURGE CURRENT

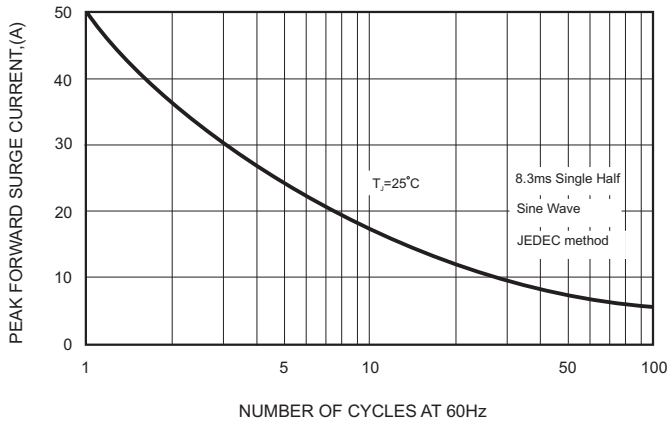

FIG.5 - TYPICAL REVERSE CHARACTERISTICS

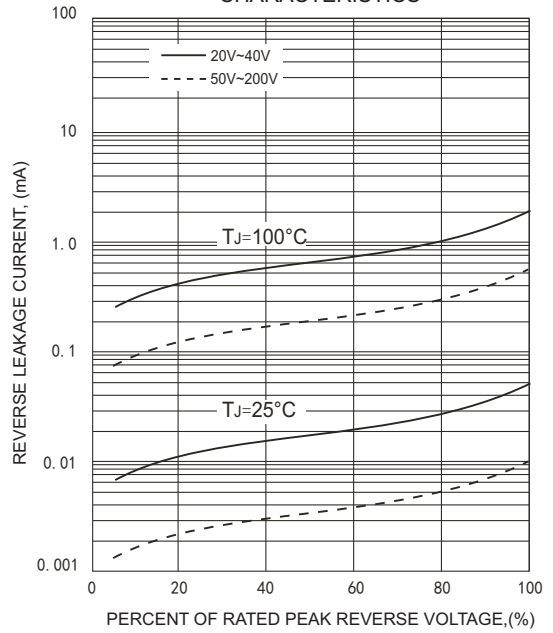
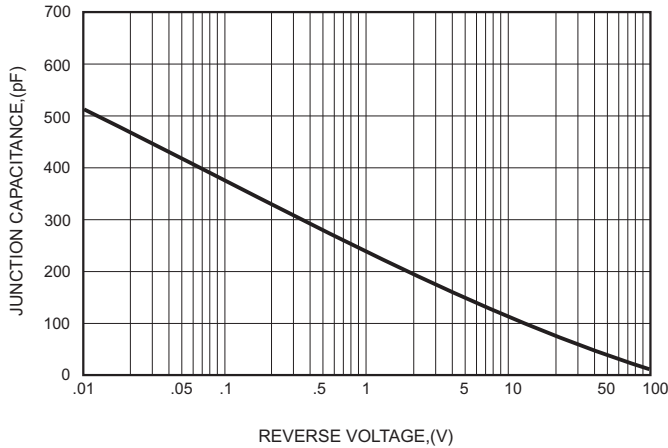



FIG.4-TYPICAL JUNCTION CAPACITANCE



# FM220-BS THRU FM2200-BS

## Pinning information

Pin	Simplified outline	Symbol
Pin1 cathode Pin2 anode		

## Marking

Type number	Marking code
FM220-BS	SK22
FM230-BS	SK23
FM240-BS	SK24
FM250-BS	SK25
FM260-BS	SK26
FM280-BS	SK28
FM2100-BS	S210
FM2150-BS	S215
FM2200-BS	S220

## Suggested solder pad layout

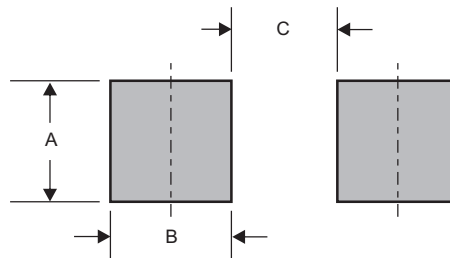

Dimensions in inches and (millimeters)

PACKAGE	A	B	C
SMB-S	0.078 (2.00)	0.059 (1.50)	0.110 (2.80)

# FM220-BS THRU FM2200-BS

## Packing information

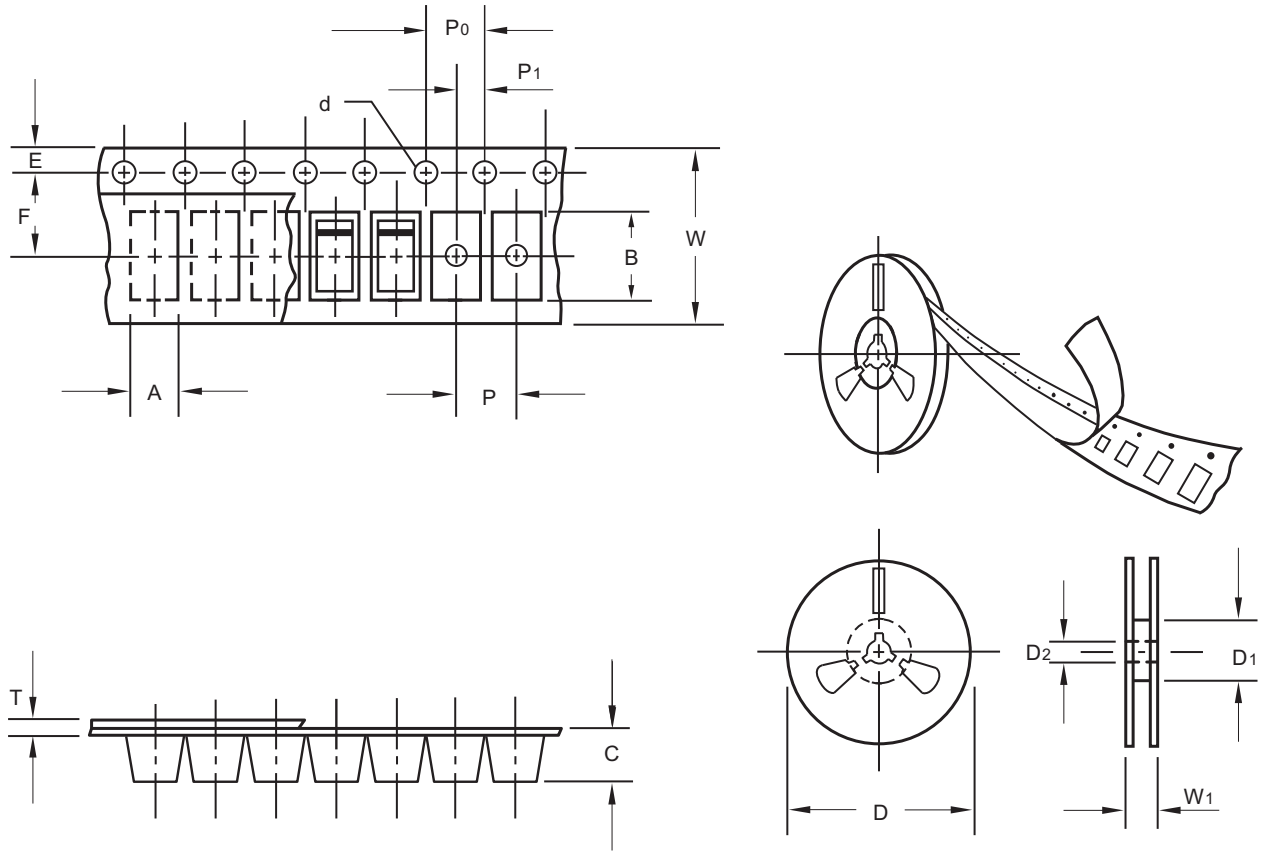

unit:mm

Item	Symbol	Tolerance	SMB-S
Carrier width	A	0.1	3.81
Carrier length	B	0.1	5.74
Carrier depth	C	0.1	2.24
Sprocket hole	d	0.1	1.50
13" Reel outside diameter	D	2.0	330.00
13" Reel inner diameter	D1	min	50.00
7" Reel outside diameter	D	2.0	178.00
7" Reel inner diameter	D1	min	62.00
Feed hole diameter	D2	0.5	13.00
Sprocket hole position	E	0.1	1.75
Punch hole position	F	0.1	5.50
Punch hole pitch	P	0.1	8.00
Sprocket hole pitch	P0	0.1	4.00
Embossment center	P1	0.1	2.00
Overall tape thickness	T	0.1	0.23
Tape width	W	0.3	12.00
Reel width	W1	1.0	18.00

Note: Devices are packed in accordance with EIA standard RS-481-A and specifications listed above.

# FM220-BS THRU FM2200-BS

## Reel packing

PACKAGE	REEL SIZE	REEL (pcs)	COMPONENT SPACING (m/m)	BOX (pcs)	INNER BOX (m/m)	REEL DIA, (m/m)	CARTON SIZE (m/m)	CARTON (pcs)	APPROX. GROSS WEIGHT (kg)
SMB-S	13"	4,000	8.0	8,000	335*335*38	330	350*330*360	64,000	13.0

## Suggested thermal profiles for soldering processes

- 1.Storage environment: Temperature=5°C~40°C Humidity=55%±25%
- 2.Reflow soldering of surface-mount devices

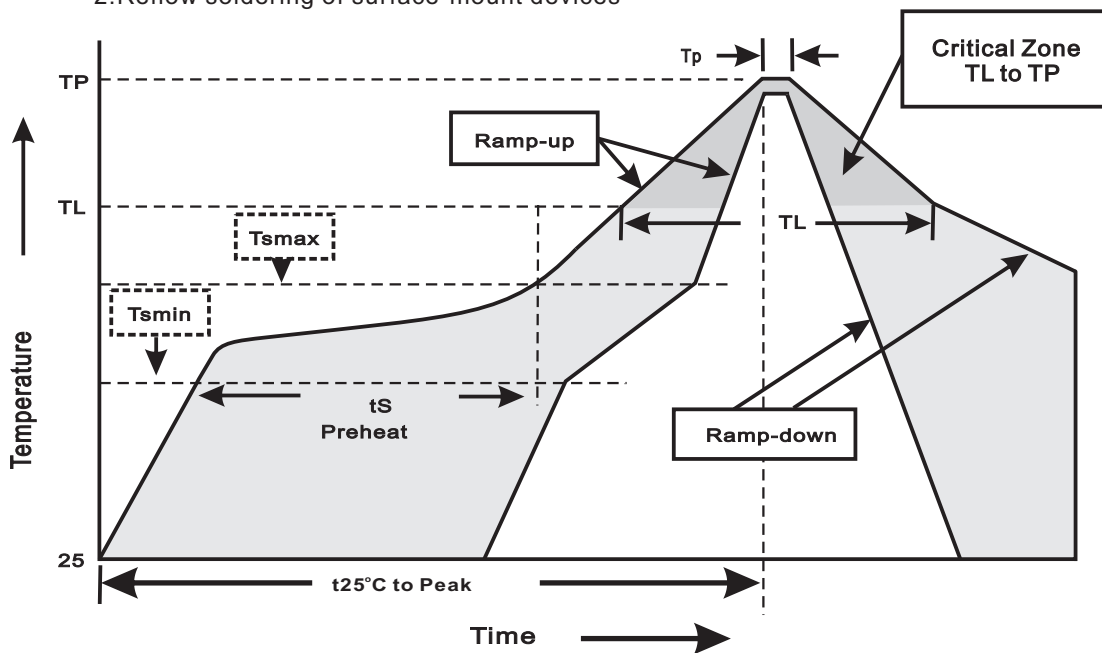

### 3.Reflow soldering

Profile Feature	Soldering Condition
Average ramp-up rate(TL to TP)	<3°C/sec
Preheat -Temperature Min(Tsmin) -Temperature Max(Tsmax) -Time(min to max)(ts)	150°C 200°C 60~120sec
Tsmax to TL -Ramp-upRate	<3°C/sec
Time maintained above: -Temperature(TL) -Time(tL)	217°C 60~260sec
Peak Temperature(TP)	255°C-0/+5°C
Time within 5°C of actual Peak Temperature(tp)	10~30sec
Ramp-down Rate	<6°C/sec
Time 25°C to Peak Temperature	<6minutes

# FM220-BS THRU FM2200-BS

## High reliability test capabilities

Item Test	Conditions	Reference
1. Solder Resistance	at 260±5°C for 10±2sec.	MIL-STD-750D METHOD-2031
2. Solderability	at 245±5°C for 5 sec.	MIL-STD-202F METHOD-208
3. High Temperature Reverse Bias	$V_R=80\%$ rate at $T_J=125^\circ\text{C}$ for 168 hrs.	MIL-STD-750D METHOD-1038
4. Forward Operation Life	Rated average rectifier current at $T_A=25^\circ\text{C}$ for 500hrs.	MIL-STD-750D METHOD-1027
5. Intermittent Operation Life	$T_A = 25^\circ\text{C}$ , $I_F = I_o$ On state: power on for 5 min. off state: power off for 5 min. on and off for 500 cycles.	MIL-STD-750D METHOD-1036
6. Pressure Cooker	$15P_{SIG}$ at $T_A=121^\circ\text{C}$ for 4 hrs.	JESD22-A102
7. Temperature Cycling	-55°C to +125°C dwelled for 30 min. and transferred for 5min. total 10 cycles.	MIL-STD-750D METHOD-1051
8. Forward Surge	8.3ms single half sine-wave , one surge.	MIL-STD-750D METHOD-4066-2
9. Humidity	at $T_A=85^\circ\text{C}$ , RH=85% for 1000hrs.	MIL-STD-750D METHOD-1021
10. High Temperature Storage Life	at 175°C for 1000 hrs.	MIL-STD-750D METHOD-1031