

# FM25CL04

## 4Kb FRAM Serial 3V Memory



### Features

#### 4K bit Ferroelectric Nonvolatile RAM

- Organized as 512 x 8 bits
- Unlimited Read/Write Cycles
- 10 Year Data Retention
- NoDelay™ Writes
- Advanced High-Reliability Ferroelectric Process

#### Very Fast Serial Peripheral Interface - SPI

- Up to 20 MHz Frequency
- Direct Hardware Replacement for EEPROM
- SPI Mode 0 & 3 (CPOL, CPHA=0,0 & 1,1)

#### Write Protection Scheme

- Hardware Protection
- Software Protection

#### Low Power Consumption

- Low Voltage Operation 2.7-3.65V
- 1  $\mu$ A Standby Current

#### Industry Standard Configuration

- Industrial Temperature -40°C to +85°C
- 8-pin SOIC

### Description

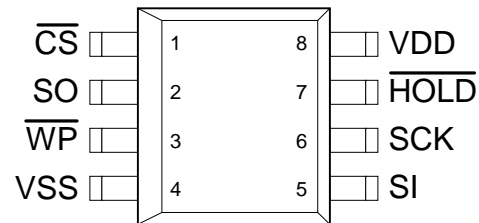
The FM25CL04 is a 4-kilobit nonvolatile memory employing an advanced ferroelectric process. A ferroelectric random access memory or FRAM is nonvolatile and performs reads and writes like a RAM. It provides reliable data retention for 10 years while eliminating the complexities, overhead, and system level reliability problems caused by EEPROM and other nonvolatile memories.

Unlike serial EEPROMs, the FM25CL04 performs write operations at bus speed. No write delays are incurred. The next bus cycle may commence immediately without the need for data polling. The next bus cycle may start immediately. In addition, the product offers virtually unlimited write endurance. Also, FRAM exhibits much lower power consumption than EEPROM.

These capabilities make the FM25CL04 ideal for nonvolatile memory applications requiring frequent or rapid writes or low power operation. Examples range from data collection, where the number of write cycles may be critical, to demanding industrial controls where the long write time of EEPROM can cause data loss.

The FM25CL04 provides substantial benefits to users of serial EEPROM as a hardware drop-in replacement. The FM25CL04 uses the high-speed SPI bus, which enhances the high-speed write capability of FRAM technology. Device specifications are guaranteed over an industrial temperature range of -40°C to +85°C.

### Pin Configuration



Pin Name	Function
/CS	Chip Select
/WP	Write Protect
/HOLD	Hold
SCK	Serial Clock
SI	Serial Data Input
SO	Serial Data Output
VDD	Supply Voltage
VSS	Ground

### Ordering Information

FM25CL04-S	8-pin SOIC
------------	------------

This is a product in sampling or pre-production phase of development. Characteristic data and other specifications are subject to change without notice.

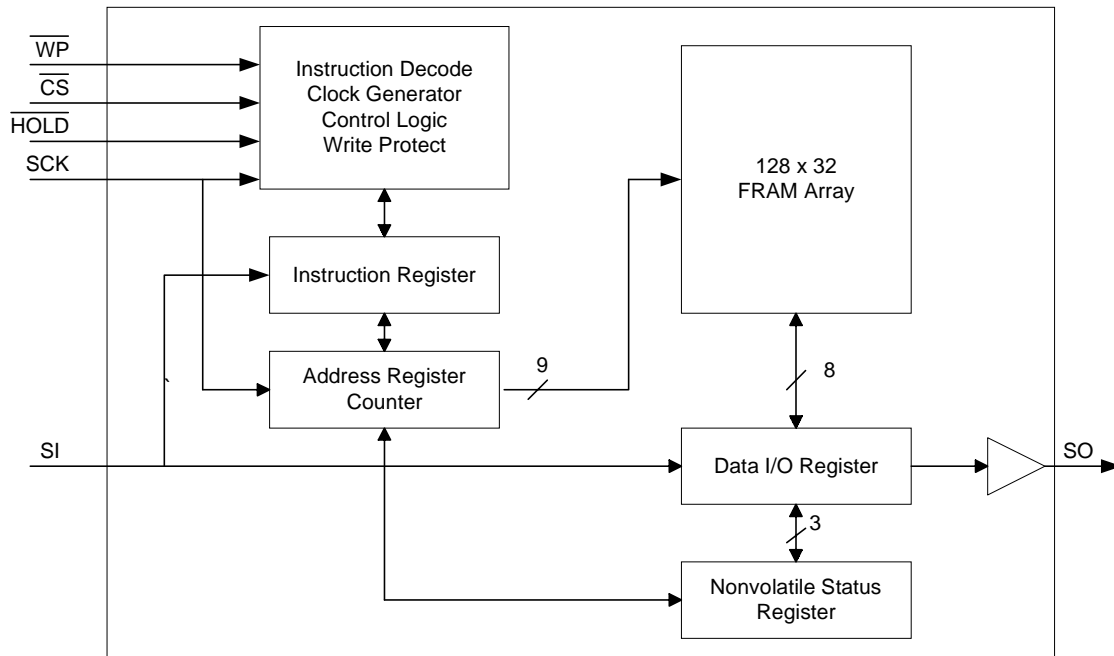


Figure 1. Block Diagram

**Pin Descriptions**

Pin Name	I/O	Description
/CS	Input	Chip Select: This active low input activates the device. When high, the device enters low-power standby mode, ignores other inputs, and all outputs are tri-stated. When low, the device internally activates the SCK signal. A falling edge on /CS must occur prior to every op-code.
SCK	Input	Serial Clock: All I/O activity is synchronized to the serial clock. Inputs are latched on the rising edge and outputs occur on the falling edge. Since the device is static, the clock frequency may be any value between 0 and 20 MHz and may be interrupted at any time.
/HOLD	Input	Hold: The /HOLD pin is used when the host CPU must interrupt a memory operation for another task. When /HOLD is low, the current operation is suspended. The device ignores any transition on SCK or /CS. All transitions on /HOLD must occur while SCK is low.
/WP	Input	Write Protect: This active low pin prevents write operations to the memory array or the status register. A complete explanation of write protection is provided below.
SI	Input	Serial Input: All data is input to the device on this pin. The pin is sampled on the rising edge of SCK and is ignored at other times. It should always be driven to a valid logic level to meet IDD specifications. * SI may be connected to SO for a single pin data interface.
SO	Output	Serial Output: This is the data output pin. It is driven during a read and remains tri-stated at all other times including when /HOLD is low. Data transitions are driven on the falling edge of the serial clock. * SO may be connected to SI for a single pin data interface.
VDD	Supply	Power Supply (2.7V to 3.65V)
VSS	Supply	Ground

## Overview

The FM25CL04 is a serial FRAM memory. The memory array is logically organized as 512 x 8 and is accessed using an industry standard Serial Peripheral Interface or SPI bus. Functional operation of the FRAM is similar to serial EEPROMs. The major difference between the FM25CL04 and a serial EEPROM with the same pinout is the FRAM's superior write performance and power consumption.

## Memory Architecture

When accessing the FM25CL04, the user addresses 512 locations of 8 data bits each. These data bits are shifted serially. The addresses are accessed using the SPI protocol, which includes a chip select (to permit multiple devices on the bus), an op-code, and an address. The upper address bit is included in the op-code. The complete address of 9-bits specifies each byte address uniquely.

Most functions of the FM25CL04 either are controlled by the SPI interface or are handled automatically by on-board circuitry. The access time for memory operation is essentially zero, beyond the time needed for the serial protocol. That is, the memory is read or written at the speed of the SPI bus. Unlike an EEPROM, it is not necessary to poll the device for a ready condition since writes occur at bus speed. So, by the time a new bus transaction can be shifted into the device, a write operation will be complete. This is explained in more detail in the interface section.

Users expect several obvious system benefits from the FM25CL04 due to its fast write cycle and high endurance as compared with EEPROM. In addition there are less obvious benefits as well. For example in a high noise environment, the fast-write operation is less susceptible to corruption than an EEPROM since it is completed quickly. By contrast, an EEPROM requiring milliseconds to write is vulnerable to noise during much of the cycle.

Note that the FM25CL04 contains no power management circuits other than a simple internal power-on reset. It is the user's responsibility to ensure that VDD is within datasheet tolerances to prevent incorrect operation.

## Serial Peripheral Interface – SPI Bus

The FM25CL04 employs a Serial Peripheral Interface (SPI) bus. It is specified to operate at speeds up to 20 MHz. This high-speed serial bus provides high performance serial communication to a host microcontroller. Many common microcontrollers have hardware SPI ports allowing a direct interface. It is quite simple to emulate the port using ordinary port pins for microcontrollers that do not. The FM25CL04 operates in SPI Mode 0 and 3.

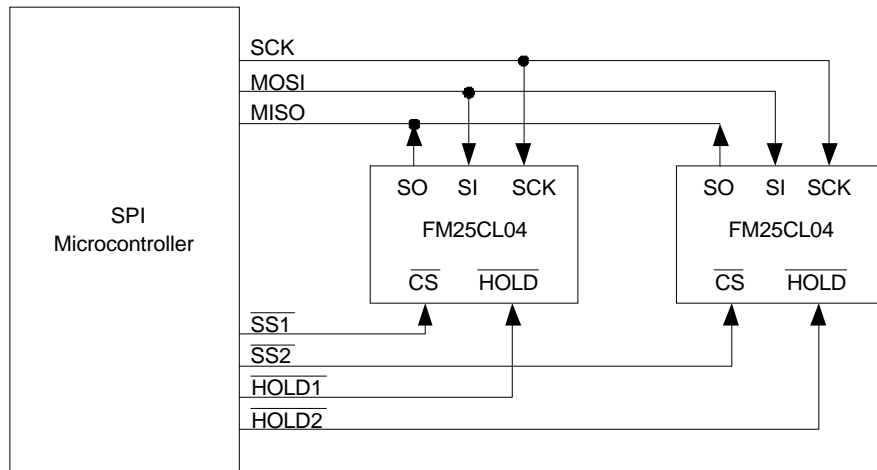
The SPI interface uses a total of four pins: clock, data-in, data-out, and chip select. It is possible to connect the two data pins together. Figure 2 illustrates a typical system configuration using the FM25CL04 with a microcontroller that offers an SPI port. Figure 3 shows a similar configuration for a microcontroller that has no hardware support for the SPI bus.

### Protocol Overview

The SPI interface is a synchronous serial interface using clock and data pins. It is intended to support multiple devices on the bus. Each device is activated using a chip select. Once chip select is activated by the bus master, the FM25CL04 will begin monitoring the clock and data lines. The relationship between the falling edge of /CS, the clock and data is dictated by the SPI mode. The device will make a determination of the SPI mode on the falling edge of each chip select. While there are four such modes, the FM25CL04 supports modes 0 and 3. Figure 4 shows the required signal relationships for modes 0 and 3. For both modes, data is clocked into the FM25CL04 on the rising edge of SCK and data is expected on the first rising edge after /CS goes active. If the clock begins from a high state, it will fall prior to beginning data transfer in order to create the first rising edge.

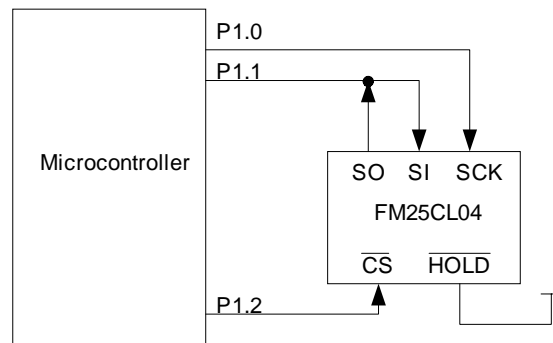
The SPI protocol is controlled by op-codes. These op-codes specify the commands to the device. After /CS is activated the first byte transferred from the bus master is the op-code. Following the op-code, any addresses and data are then transferred.

Certain op-codes are commands with no subsequent data transfer. The /CS must go inactive after an operation is complete and before a new op-code can be issued. There is one valid op-code only per active chip select.



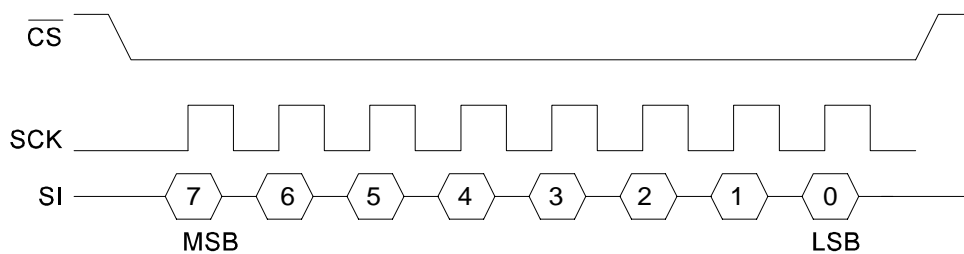
MOSI : Master Out Slave In  
 MISO : Master In Slave Out  
 SS : Slave Select

**Figure 2. System Configuration with SPI port**

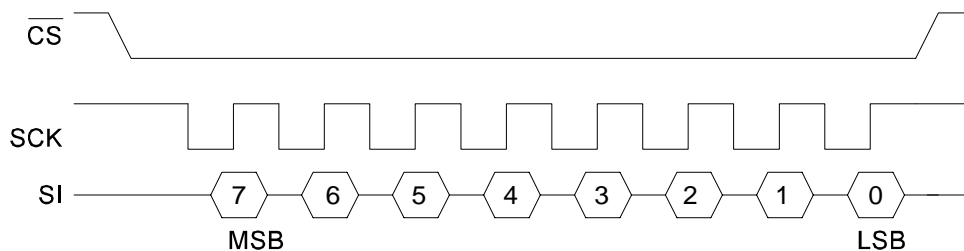


**Figure 3. System Configuration without SPI port**

SPI Mode 0: CPOL=0, CPHA=0



SPI Mode 3: CPOL=1, CPHA=1



**Figure 4. SPI Modes 0 & 3**

**Data Transfer**

All data transfers to and from the FM25CL04 occur in 8-bit groups. They are synchronized to the clock signal (SCK), and they transfer most significant bit (MSB) first. Serial inputs are registered on the rising edge of SCK. Outputs are driven from the falling edge of SCK.

**Command Structure**

There are six commands called op-codes that can be issued by the bus master to the FM25CL04. They are listed in the table below. These op-codes control the functions performed by the memory. They can be divided into three categories. First, there are commands that have no subsequent operations. They perform a single function such as to enable a write operation. Second are commands followed by one byte, either in or out. They operate on the status register. The third group includes commands for memory transactions followed by address and one or more bytes of data.

**Table 1. Op-code Commands**

Name	Description	Op-code
WREN	Set Write Enable Latch	00000110b
WRDI	Write Disable	00000100b
RDSR	Read Status Register	00000101b
WRSR	Write Status Register	00000001b
READ	Read Memory Data	0000A011b
WRITE	Write Memory Data	0000A010b

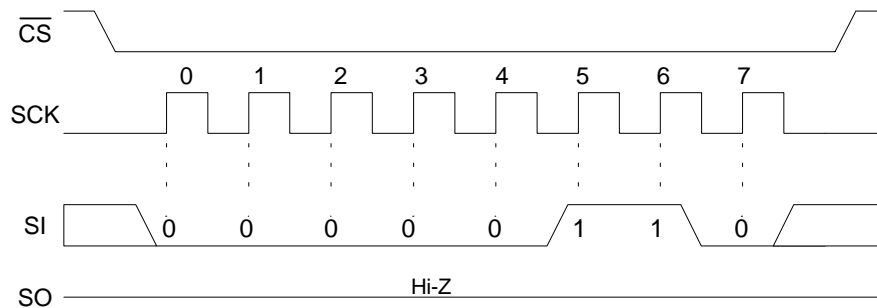
**WREN - Set Write Enable Latch**

The FM25CL04 will power up with writes disabled. The WREN command must be issued prior to any write operation. Sending the WREN op-code will allow the user to issue subsequent op-codes for write operations. These include writing the status register and writing the memory.

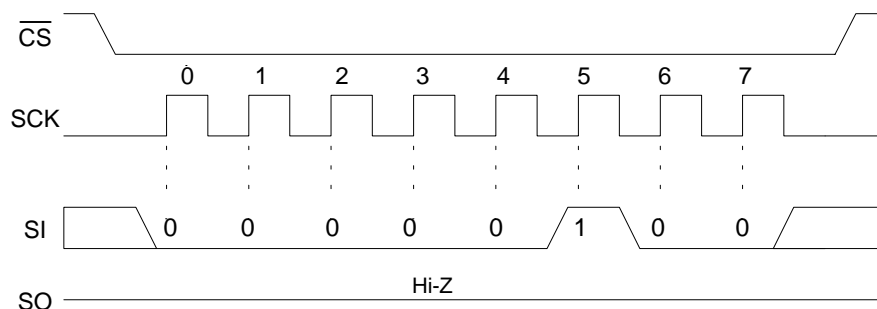
Sending the WREN op-code causes the internal Write Enable Latch to be set. A flag bit in the status register, called WEL, indicates the state of the latch. WEL=1 indicates that writes are permitted. Attempting to write the WEL bit in the status register has no effect. Completing any write operation will automatically clear the write-enable latch and prevent further writes without another WREN command. Figure 5 below illustrates the WREN command bus configuration.

**WRDI - Write Disable**

The WRDI command disables all write activity by clearing the Write Enable Latch. The user can verify that writes are disabled by reading the WEL bit in the status register and verifying that WEL=0. Figure 6 illustrates the WRDI command bus configuration.



**Figure 5. WREN Bus Configuration**



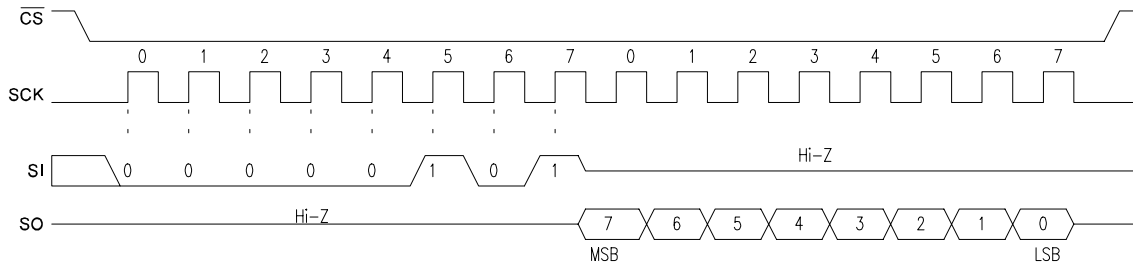
**Figure 6. WRDI Bus Configuration**

**RDSR - Read Status Register**

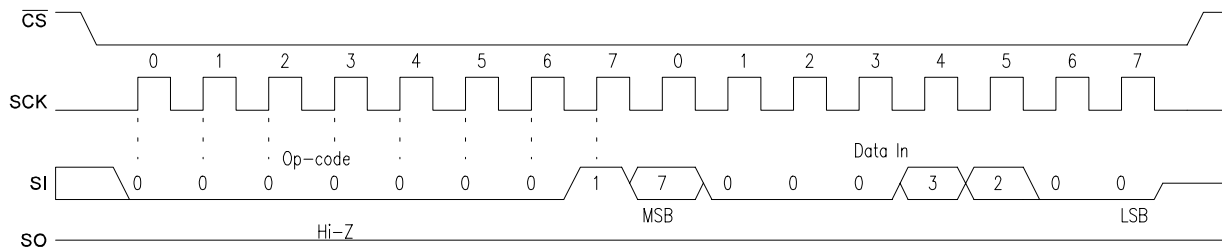
The RDSR command allows the bus master to verify the contents of the Status register. Reading Status provides information about the current state of the write protection features. Following the RDSR op-code, the FM25CL04 will return one byte with the contents of the Status register. The Status register is described in detail in a later section.

**WRSR – Write Status Register**

The WRSR command allows the user to select certain write protection features by writing a byte to the Status register. Prior to issuing a WRSR command, the /WP pin must be high or inactive. Prior to sending the WRSR command, the user must send a WREN command to enable writes. Note that executing a WRSR command is a write operation and therefore clears the Write Enable Latch. The bus configuration of RDSR and WRSR are shown below.



**Figure 7. RDSR Bus Configuration**



**Figure 8. WRSR Bus Configuration**

**Status Register & Write Protection**

The write protection features of the FM25CL04 are multi-tiered. Taking the /WP pin to a logic low state is the hardware write protect function. All write operations are blocked when /WP is low. To write the memory with /WP high, a WREN op-code must first be issued. Assuming that writes are enabled using WREN and by /WP, writes to memory are controlled by the Status register. As described above, writes to the status register are performed using the WRSR command and subject to the /WP pin. The Status register is organized as follows.

**Table 2. Status Register**

Bit	7	6	5	4	3	2	1	0
Name	0	0	0	0	BP1	BP0	WEL	0

Bits 0 and 7-4 are fixed at 0 and cannot be modified. Note that the Ready bit in many EEPROMs is unnecessary as the FRAM writes in real-time and is never busy. The BP1 and BP0 control software write protection features. They are nonvolatile! The WEL

flag indicates the state of the Write Enable Latch. Writing the WEL bit in the status register has no effect.

BP1 and BP0 are memory block write protection bits. They specify portions of memory that are write protected as shown in the following table.

**Table 3. Block Memory Write Protection**

BP1	BP0	Protected Address Range
0	0	None
0	1	180h to 1FFh (upper ¼)
1	0	100h to 1FFh (upper ½)
1	1	000h to 1FFh (all)

The BP1 and BP0 bits allow software to selectively write protect the array. These settings are only used when the /WP pin is inactive and the WREN command has been issued. The following table summarizes the write protection conditions.

**Table 4. Write Protection**

WEL	/WP	Protected Blocks	Unprotected Blocks	Status Register
0	X	Protected	Protected	Protected
1	0	Protected	Protected	Protected
1	1	Protected	Unprotected	Unprotected

### Memory Operation

The SPI interface, which is capable of a relatively high clock frequency, highlights the fast write capability of the FRAM technology. Unlike SPI-bus EEPROMs, the FM25CL04 can perform sequential writes at bus speed. No page register is needed and any number of sequential writes may be performed.

#### Write Operation

All writes to the memory array begin with a WREN op-code. The next op-code is the WRITE instruction. This op-code must include the address MSB. It is followed by a single byte address value. In total, the 9-bits specify the address of the first byte of the write operation. Subsequent bytes are data and they are written sequentially. Addresses are incremented internally as long as the bus master continues to issue clocks. If the last address of 1FFh is reached, the counter will roll over to 000h. Data is written MSB first. A write operation is shown in Figure 9.

Unlike EEPROMs, any number of bytes can be written sequentially and each byte is written to memory immediately after it is clocked in (after the 8<sup>th</sup> clock). The rising edge of /CS terminates a WRITE op-code operation. Asserting /WP active in

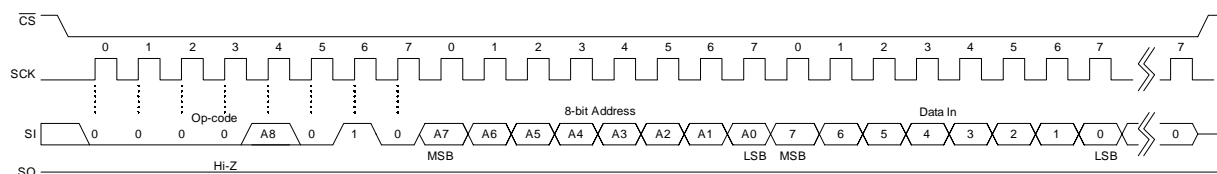
the middle of a write operation will have no affect until the byte being written has completed.

#### Read Operation

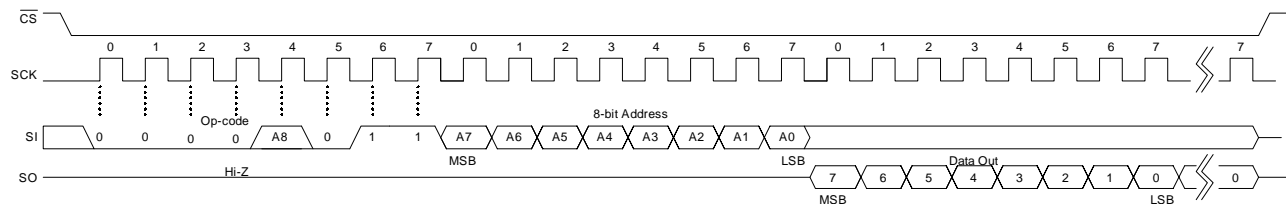
After the falling edge of /CS, the bus master can issue a READ op-code. This op-code must include the address MSB. It is followed by a single byte address value. In total, the 9-bits specify the address of the first byte of the read operation. After the op-code and address are complete, the SI line is ignored. The bus master issues 8 clocks, with one bit read out for each. Addresses are incremented internally as long as the bus master continues to issue clocks. If the last address of 1FFh is reached, the counter will roll over to 000h. Data is read MSB first. The rising edge of /CS terminates a READ op-code operation. A read operation is shown in Figure 10.

#### Hold

The /HOLD pin can be used to interrupt a serial operation without aborting it. If the bus master pulls the /HOLD pin low while SCK is low, the current operation will pause. Taking the /HOLD pin high while SCK is low will resume an operation. The transitions of /HOLD must occur while SCK is low, but the SCK and /CS pins can toggle during a hold state.



**Figure 9. Memory Write**



**Figure 10. Memory Read**

## Electrical Specifications

### Absolute Maximum Ratings

Symbol	Description	Ratings
$V_{DD}$	Power Supply Voltage with respect to $V_{SS}$	-1.0V to +5.0V
$V_{IN}$	Voltage on any pin with respect to $V_{SS}$	-1.0V to +5.0V and $V_{IN} < V_{DD} + 1.0V$
$T_{STG}$	Storage Temperature	-55°C to +125°C
$T_{LEAD}$	Lead Temperature (Soldering, 10 seconds)	300° C

Stresses above those listed under Absolute Maximum Ratings may cause permanent damage to the device. This is a stress rating only, and the functional operation of the device at these or any other conditions above those listed in the operational section of this specification is not implied. Exposure to absolute maximum ratings conditions for extended periods may affect device reliability.

### DC Operating Conditions ( $T_A = -40^\circ\text{C}$ to $+85^\circ\text{C}$ , $V_{DD} = 2.7V$ to $3.65V$ unless otherwise specified)

Symbol	Parameter	Min	Typ	Max	Units	Notes
$V_{DD}$	Power Supply Voltage	2.7	3.3	3.65	V	
$I_{DD}$	VDD Supply Current @ SCK = 100 kHz @ SCK = 1.0 MHz @ SCK = 5.0 MHz @ SCK = 20.0 MHz		0.05 0.2 1.4 5	0.075 0.8 3.0 10.0	mA	1
$I_{SB}$	Standby Current	-		1	$\mu\text{A}$	2
$I_{LI}$	Input Leakage Current	-		10	$\mu\text{A}$	3
$I_{LO}$	Output Leakage Current	-		10	$\mu\text{A}$	3
$V_{IH}$	Input High Voltage	$0.7 V_{DD}$		$V_{DD} + 0.5$	V	
$V_{IL}$	Input Low Voltage	-0.3		$0.3 V_{DD}$	V	
$V_{OH}$	Output High Voltage @ $I_{OH} = -2\text{ mA}$	$V_{DD} - 0.8$		-	V	
$V_{OL}$	Output Low Voltage @ $I_{OL} = 2\text{ mA}$	-		0.4	V	
$V_{HYS}$	Input Hysteresis	$0.05 V_{DD}$		-	V	4

### Notes

- SCK toggling between  $V_{DD} - 0.3V$  and  $V_{SS}$ , other inputs  $V_{SS}$  or  $V_{DD} - 0.3V$ .
- $SCK = SI = /CS = V_{DD}$ . All inputs  $V_{SS}$  or  $V_{DD}$ .
- $V_{SS} \leq V_{IN} \leq V_{DD}$  and  $V_{SS} \leq V_{OUT} \leq V_{DD}$ .
- Guaranteed by design.



**AC Parameters** ( $T_A = -40^\circ\text{C}$  to  $+85^\circ\text{C}$ ,  $C_L = 30\text{pF}$ ,  $V_{DD} = 2.7\text{V}$  to  $3.65\text{V}$  unless otherwise specified)

Symbol	Parameter	Min	Max	Units	Notes
$f_{CK}$	SCK Clock Frequency	0	20	MHz	
$t_{CH}$	Clock High Time	22		ns	1
$t_{CL}$	Clock Low Time	22		ns	1
$t_{CSU}$	Chip Select Setup	10		ns	
$t_{CSH}$	Chip Select Hold	10		ns	
$t_{OD}$	Output Disable Time		20	ns	2
$t_{ODV}$	Output Data Valid Time		20	ns	
$t_{OH}$	Output Hold Time	0		ns	
$t_D$	Deselect Time	60		ns	
$t_R$	Data In Rise Time		50	ns	1,3
$t_F$	Data In Fall Time		50	ns	1,3
$t_{SU}$	Data Setup Time	5		ns	
$t_H$	Data Hold Time	5		ns	
$t_{HS}$	/Hold Setup Time	10		ns	
$t_{HH}$	/Hold Hold Time	10		ns	
$t_{HZ}$	/Hold Low to Hi-Z		20	ns	2
$t_{LZ}$	/Hold High to Data Active		20	ns	2

**Notes**

- $t_{CH} + t_{CL} = 1/f_{CK}$ .
- Guaranteed by design.
- Rise and fall times measured between 10% and 90% of waveform.

**Capacitance** ( $T_A = 25^\circ\text{C}$ ,  $f = 1.0\text{MHz}$ ,  $V_{DD} = 3.3\text{V}$ )

Symbol	Parameter	Min	Max	Units	Notes
$C_O$	Output capacitance (SO)	-	8	pF	1
$C_I$	Input capacitance	-	6	pF	1

**Notes**

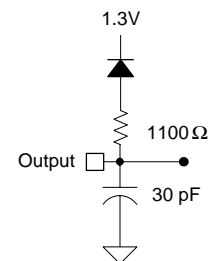
- Guaranteed by design.

**Data Retention** ( $T_A = -40^\circ\text{C}$  to  $+85^\circ\text{C}$ ,  $C_L = 30\text{pF}$ ,  $V_{DD} = 2.7\text{V}$  to  $3.65\text{V}$  unless otherwise specified)

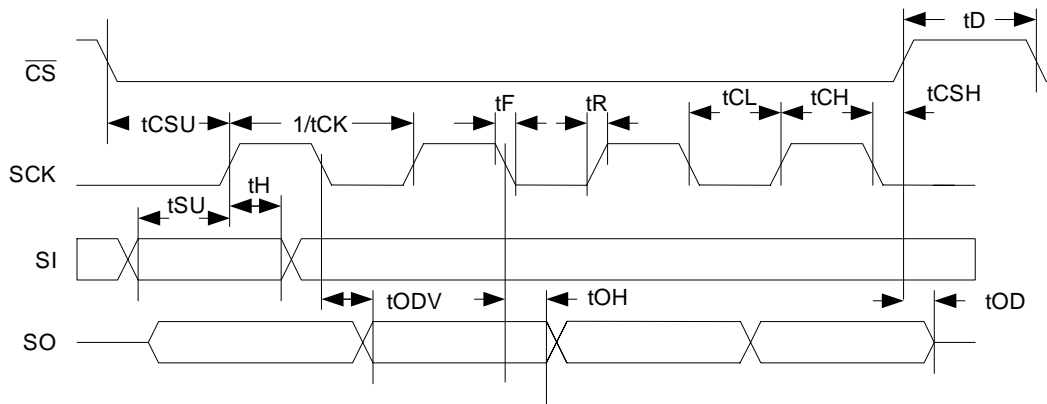
Parameter	Min	Max	Units	Notes
Data Retention	10	-	Years	

**AC Test Conditions**

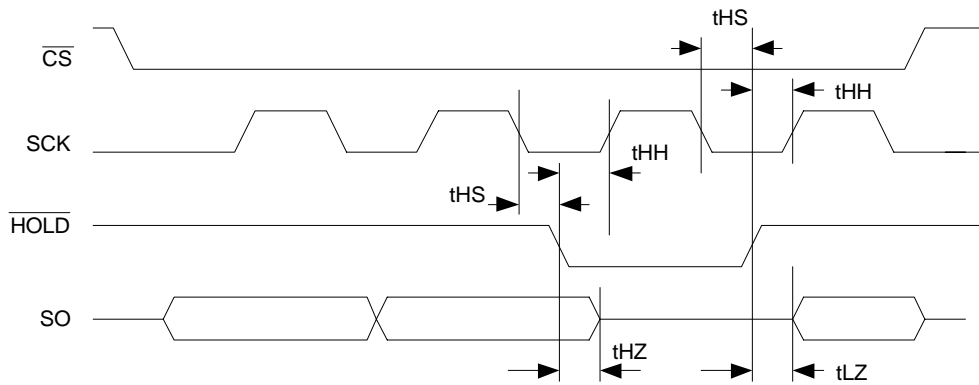
Input Pulse Levels	10% and 90% of $V_{DD}$
Input rise and fall times	5 ns
Input and output timing levels	30% and 70% of $V_{DD}$

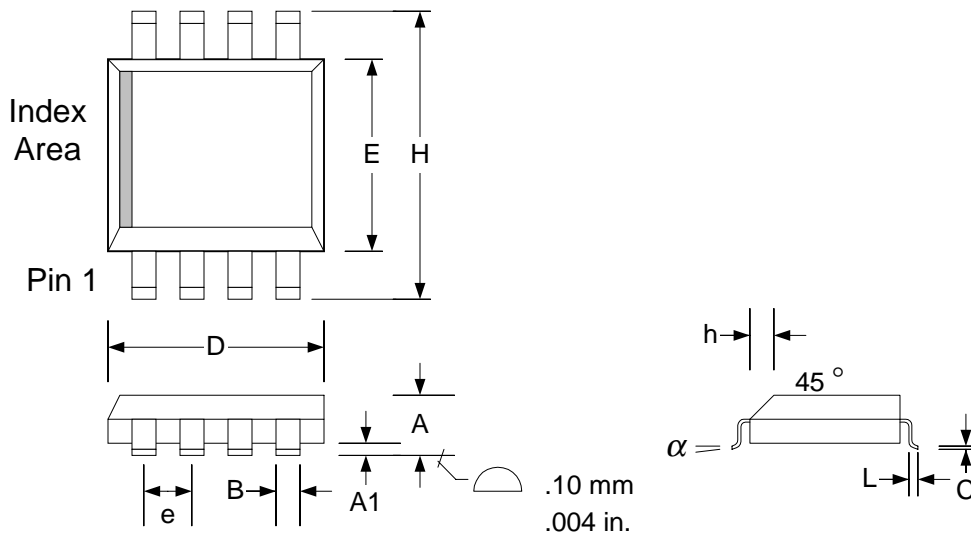
**Equivalent AC Load Circuit**


**Serial Data Bus Timing**



**/Hold Timing**



**8-pin SOIC (JEDEC MS-012 variation AA)**

**Selected Dimensions**

Refer to JEDEC MS-012 for complete dimensions and notes.

Controlling dimensions in millimeters.

Conversions to inches are not exact.

Symbol	Dim	Min	Nom.	Max
A	mm in.	1.35 0.053		1.75 0.069
A1	mm in.	0.10 0.004		0.25 0.010
B	mm in.	0.33 0.013		0.51 0.020
C	mm in.	0.19 0.007		0.25 0.010
D	mm in.	4.80 0.189		5.00 0.197
E	mm in.	3.80 0.150		4.00 0.157
e	mm in.		1.27 BSC 0.050 BSC	
H	mm in.	5.80 0.228		6.20 0.244
h	mm in.	0.25 0.010		0.50 0.197
L	mm in.	0.40 0.016		1.27 0.050
$\alpha$		0°		8°