

FM25Q32

32M-BIT

Serial Flash Memory with 4KB Sectors, Dual and Quad I/O SPI



Documents title

32M bit Serial Flash Memory with 4KB Sectors, Dual and Quad I/O SPI

Revision History

Revision No.	History	Draft date	Remark
0.0	Initial Draft	Apr.2010	preliminary
0.1	Flash Part Numbering System	Jul.2010	preliminary
0.2	Write Status Register (01h) previous bits => cleared to 0 Change Read instructions tSHSL20ns => 10ns Change	Aug.18.2010	preliminary
0.3	Add Read SFDP (5Ah)	Dec.02.2010	final
0.4	Revised ICC2/ICC4	Dec.24.2010	final
0.5	Add Dual/Quad output fast read Add SFDP definition table Revised Part Numbering System	Jan.13.2011	final
0.6	Add VSOP Modified some descriptions	May.20.2011	Final

Table of Contents

1.	FEATURES.....	5
2.	GENERAL DESCRIPTION.....	5
3.	PIN / PAD CONFIGURATION.....	6
3.1	8-Pin SOIC 208-MIL / VSOP 208-MIL.....	6
3.2	8-Pad WSON 6X5-MM.....	6
3.3	8-Pin PDIP 300-MIL.....	6
3.4	16-Pin SOIC 300-MIL.....	7
4.	PIN / PAD DESCRIPTION.....	8
4.1	SOIC 208-MIL, VSOP 208-MIL, WSON 6X5-MM, PDIP 300-MIL.....	8
4.2	SOIC 300-MIL.....	8
4.3	Package Type.....	8
5.	SIGNAL DESCRIPTION.....	9
5.1	Chip Select (/CS).....	9
5.2	Serial Data Input, Output and IOs (DI, DO and IO0, IO1, IO2, IO3).....	9
5.3	Write Protect (/WP).....	9
5.4	HOLD (/HOLD).....	9
5.5	Serial Clock (CLK).....	9
6.	BLOCK DIAGRAM.....	10
7.	FUNCTIONAL DESCRIPTION.....	11
7.1	Standard SPI Instructions.....	11
7.2	Dual SPI Instructions.....	11
7.3	Quad SPI Instructions.....	11
7.4	Hold Function.....	11
8.	WRITE PROTECTION.....	12
8.1	Write protect Features.....	12
9.	STATUS REGISTER.....	13
9.1	BUSY.....	14
9.2	Write Enable Latch (WEL).....	14
9.3	Block Protect Bits (BP2, BP1, BP0).....	14
9.4	Top/Bottom Block protect (TB).....	14
9.5	Sector/Block Protect (SEC).....	14
9.6	Status Register protect (SRP1, SRP0).....	15
9.7	Erase/Program Suspend Status (SUS).....	15
9.8	Quad Enable (QE).....	15
9.9	Status Register Memory Protection.....	16
10.	INSTRUCTIONS.....	17
10.1	Manufacturer and Device Identification.....	17
10.2	Instruction Set Table 1.....	18
10.3	Instruction Set Table 2.....	19
10.4	Write Enable (06h).....	20
10.5	Write Enable for Volatile Status Register (50h).....	20
10.6	Write Disable (04h).....	21
10.7	Read Status Register-1 (05h) and Read Status Register-2 (35h).....	21
10.8	Write Status Register (01h).....	22
10.9	Read Data (03h).....	23
10.10	Fast Read (0Bh).....	23
10.11	Fast Read Dual Output (3Bh).....	24
10.12	Fast Read Quad Output (6Bh).....	25
10.13	Fast Read Dual I/O (BBh).....	26
10.14	Fast Read Quad I/O (EBh).....	28
10.15	Page Program (02h).....	39
10.16	Quad Data Input Page Program (32h).....	30
10.17	Quad Data Page Program (38h).....	31
10.18	Sector Erase (20h).....	32

10.19	32KB Block Erase (52h).....	33
10.20	64KB Block Erase (D8h).....	34
10.21	Chip Erase (C7h / 60h).....	35
10.22	Erase / Program Suspend (75h).....	36
10.23	Erase / Program Resume (7Ah).....	37
10.24	Deep Power-down (B9h).....	38
10.25	Release Deep Power-down / Device ID (ABh).....	39
10.26	Read Manufacturer/ Device ID (90h),(EFh),(DFh).....	40
10.27	JEDEC ID (9Fh).....	42
10.28	Read Serial Flash Discovery Parameter(5Ah).....	43
10.29	Mode Bit Reset (FFh).....	46
10.30	Enter Secured OTP (B1h).....	46
10.31	Exit Secured OTP (C1h).....	47
10.32	Read Security Register (2Bh).....	47
10.33	Write Security Register (2Fh).....	48
10.34	Set Burst with Wrap (77h).....	49
11.	4K-bit Secured OTP.....	50
12.	ELECTRICAL CHARACTERISTICS.....	51
12.1	Absolute Maximum Ratings.....	51
12.2	Operating Ranges.....	51
12.3	Endurance and Data Retention.....	52
12.4	Power-up Timing and Write Inhibit Threshold.....	52
12.5	DC Electrical Characteristics.....	53
12.6	AC Measurement Conditions.....	54
12.7	AC Electrical Characteristics.....	55
12.8	AC Electrical Characteristics (cont'd).....	56
12.9	Serial Output Timing.....	57
12.10	Input Timing.....	57
12.11	Hold Timing.....	57
13.	PACKAGE SPECIFICATION.....	58
13.1	8-Pin SOIC 208-mil.....	58
13.2	8-Pin VSOP 208-mil.....	59
13.3	8-Pin PDIP 300-mil.....	60
13.4	8-contact 6x5 WSON.....	61
13.5	8-contact 6x5 WSON Cont'd.....	62
13.6	16-Pin SOIC 300-mil.....	63
14.	ORDERING INFORMATION.....	64

1. FEATURES

■ SPI Flash Memory

- 32M-bit / 4M-byte Serial Flash
- 256-bytes per programmable page
- 4K-bit secured OTP

■ Standard, Dual or Quad SPI

- Standard SPI: CLK, /CS, DI, DO, /WP, /Hold
- Dual SPI: CLK, /CS, IO₀, IO₁, /WP, /Hold
- Quad SPI: CLK, /CS, IO₀, IO₁, IO₂, IO₃

■ High Performance

- 104MHz clock operation
- 208MHz equivalent Dual SPI
- 416MHz equivalent Quad SPI
- 50MB/S continuous data transfer rate
- 31MB/S random access (32-byte fetch)
- Comparable to X16 Parallel Flash

■ Flexible Architecture

- Uniform Sector Erase (4K-byte)
- Block Erase (32K and 64K-bytes)
- Erase/Program Suspend & Resume

■ Endurance

- 100K program/ erase cycles

■ Low Power Consumption

- Single 2.7 to 3.6V supply
- 5mA active current
- <3μA Deep Power-down (typ.)

■ wide Temperature Range

- -40°C to +85°C operating range

■ Advanced Security Features

- Software and Hardware Write-protect
- Top or Bottom, Sector or Block selection
- Lock-Down and OTP protection

■ Package Options

- 8-pin SOIC 208-mil
- 8-pad WSON 6x5-mm
- 16-pin SOIC 300-mil
- 8-pin DIP 300-mil
- 8-pin VSOP 208-mil

■ Package Material

- Fidelix all product Green package
- Lead-free & Halogen-free
- RoHS Compliant

2. GENERAL DESCRIPTION

The FM25Q32 SPI flash supports the standard Serial peripheral Interface (SPI), and supports the Dual/Quad SPI: Serial Clock, Chip Select, Serial Data I/O0(DI), I/O1(DO), I/O2(/WP), and I/O3(/HOLD).

SPI clock frequencies of up to 104MHz are supported allowing equivalent clock rates of 208MHz for Dual Output and 416MHz for Quad Output when using the Fast Read Dual/Quad I/O instructions. These transfer rates are comparable to those of 8 and 16-bit Parallel Flash memories.

The FM25Q32 array is organized into 16.384 programmable pages of 256-bytes each. Up to 256 bytes can be programmed at a time using the Page Program instructions. Pages can be erased Sector, 32KB Block, 64KB Block or the entire chip.

The devices operate on a single 2.7V to 3.6V power supply with current consumption as low as 5mA active and 3μA for Deep Power-down. All devices offered in space-saving packages. The device supports JEDEC standard manufacturer and device identification with a 4K-bit Secured OTP.

3. PIN / PAD CONFIGURATION

3.1 8-Pin SOIC 208-MIL / VSOP 208-MIL

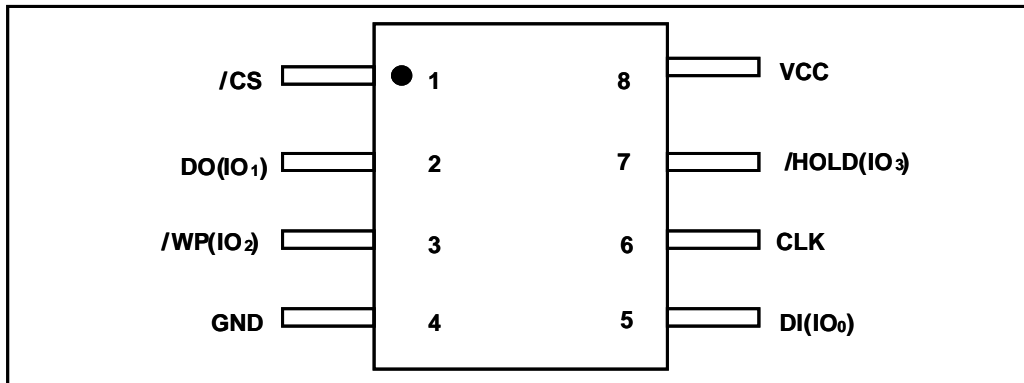

Figure 1a. Pin Assignments, 8-pin SOIC 208-mil / VSOP 208-mil

3.2 8-Pad WSON 6X5-MM

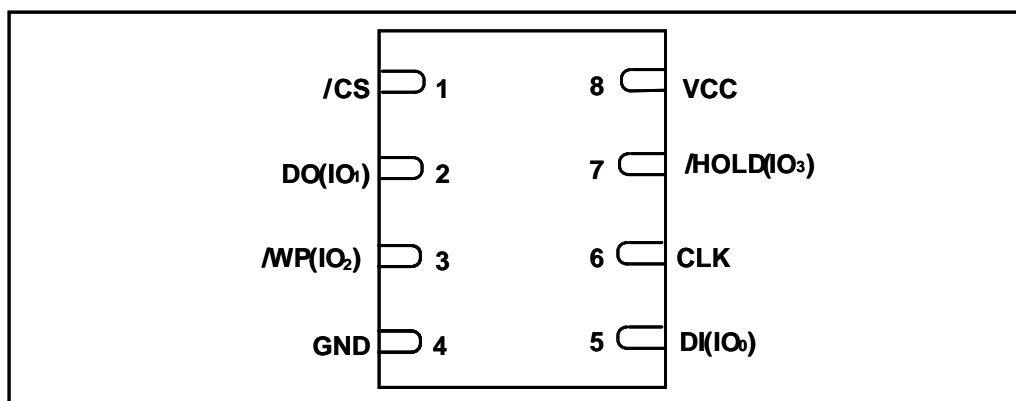

Figure 1b. Pad Assignments, 8-pad WSON

3.3 8-Pin PDIP 300-MIL

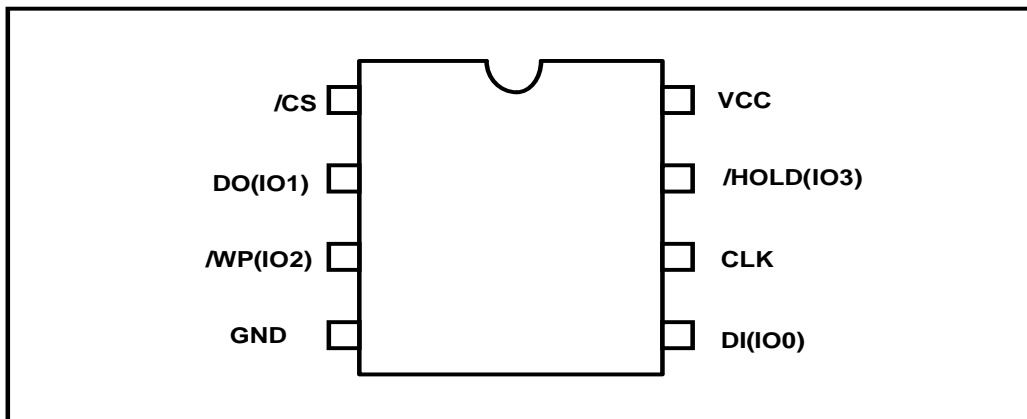

Figure 1c. Pin Assignments, 8-pin PDIP 300-mil

3.4 16-Pin SOIC 300-MIL

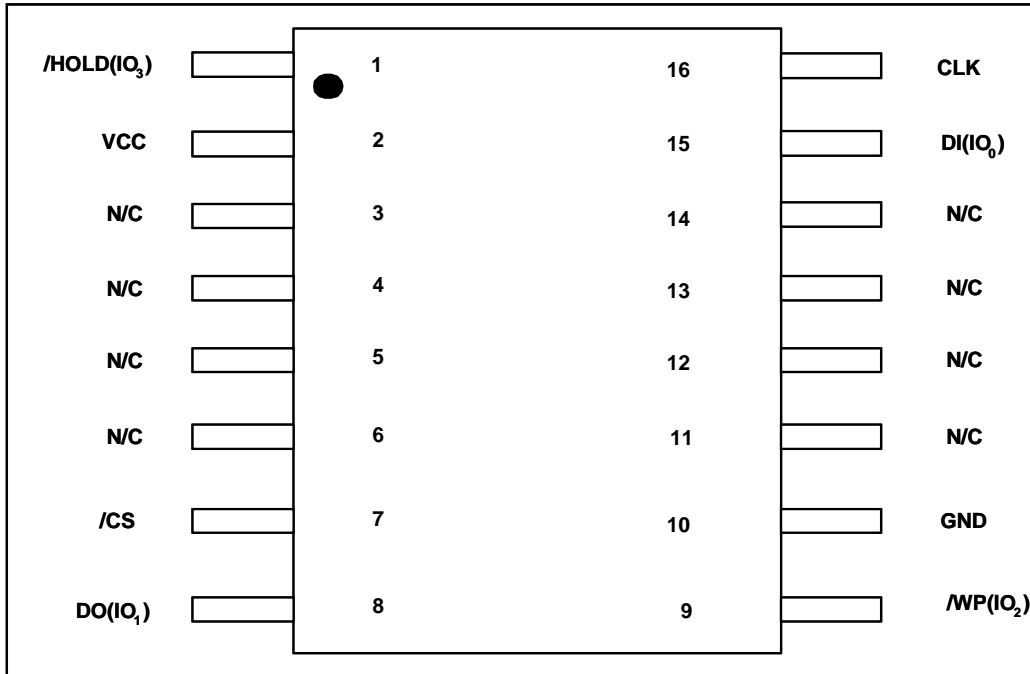

Figure 1d. Pin Assignments, 16-pin SOIC 300-mil

4. PIN / PAD DESCRIPTION

4.1 SOIC 208-MIL, VSOP 208-MIL, WSON 6X5-MM, PDIP 300-MIL

PIN NO.	PIN NAME	I/O	FUCTION
1	/CS	I	Chip Select Input
2	DO(IO1)	I/O	Data Output (Data Input Output 1)* ¹
3	/WP(IO2)	I/O	Write Protect Input (Data Input output) * ²
4	GND		Ground
5	DI(IO0)	I/O	Data Input (Data Input Output 0)* ¹
6	CLK	I	Serial Clock Input
7	/HOLD(IO3)	I/O	Hold Input (Data Input output 3) * ²
8	VCC		Power Supply

*1 IO0 and IO1 are used for Dual and Quad instructions

*2 IO0 – IO3 are used for Quad instructions

4.2 SOIC 300-MIL

PAD NO.	PAD NAME	I/O	FUCTION
1	/HOLD(IO3)	I/O	Hold Input(Data Input Output 3)* ²
2	VCC		Power Supply
3	N/C		No Connect
4	N/C		No Connect
5	N/C		No Connect
6	N/C		No Connect
7	/CS	I	Chip Select Input
8	DO(IO1)	I/O	Data output (Data Input Output 1)* ¹
9	/WP(IO2)	I/O	Write Protection Input (Data Input Output 2)* ²
10	GND		Ground
11	N/C		No Connect
12	N/C		No Connect
13	N/C		No Connect
14	N/C		No Connect
15	DI(IO0)	I/O	Data Input (Data Input Output 0)* ¹
16	CLK	I	Serial Clock Input

*1 IO0 and IO1 are used for Dual and Quad instructions

*2 IO0_ IO3 are used for Quad instructions

4.3 Package Type

FM25Q32 is offered in an 8-pin plastic 208-mil width VSOP, 8-pin plastic 208-mil width SOIC, 6x5-mm WSON, 8-pin PDIP and 16-pin plastic 300-mil width SOIC as shown in figure 1a, 1b,1c and 1d respectively. Package diagrams and dimensions are illustrated at the end of this datasheet.

5. SIGNAL DESCRIPTION

5.1 Chip Select (/CS)

When this input signal is high, the device is deselected and serial data output is at high impedance. Unless an internal program, erase or write status register cycle is in progress, the device will be in the standby power mode (this is not the deep power-down mode). Driving Chip Select (/CS) low enables the device, placing it in the active power mode. After power-up, a falling edge on Chip Select (/CS) is required prior to the start of any instruction.

5.2 Serial Data Input, Output and IOs (DI, DO and IO0, IO1, IO2, IO3)

The FM25Q32 supports standard SPI, Dual SPI and Quad SPI operation. Standard SPI instructions use the serial DI (input) pin to write instructions, addresses or data to the device on the rising edge of the Serial Clock (CLK) input pin. Standard SPI also uses the serial DO (output) to read data or status from the device on the falling edge of CLK.

Dual and Quad SPI instructions use the serial IO pins to write instructions, addresses or data to the device on the rising edge of CLK and read data or status from the device on the falling edge of CLK. Quad SPI instructions require the non-volatile Quad Enable bit (QE) in Status Register-2 to be set. When QE=1 the /WP pin becomes IO2 and /HOLD pin becomes IO3.

5.3 Write Protect (/WP)

The Write Protect (/WP) pin can be used to protect the Status Register against data modification. Used in company with the Status Register's Block Protect (SEC, TB, BP2, BP1 and BP0) bits and Status Register Protect (SRP) bits, a portion or the entire memory array can be hardware protected. The /WP pin is active low. When the QE bit of Status Register-2 is set for Quad I/O, the /WP pin (Hardware Write Protect) function is not available since this pin is used for IO2. See figure 1a, 1b, 1c and 1d for the pin configuration of Quad I/O operation.

5.4 HOLD (/HOLD)

The /HOLD pin is used to pause any serial communications with the device without deselecting the device. When /HOLD goes low, while /CS is low, the DO pin will be at high impedance and signals on the DI and CLK pins will be ignored (don't care). When /HOLD goes high, device operation can resume. The /HOLD function can be useful when multiple devices are sharing the same SPI signals. The /HOLD pin is active low. When the QE bit of Status Register-2 is set Quad I/O, the /HOLD pin function is not available since this pin used for IO3. See figure 1a, 1b, 1c and 1d for the pin configuration of Quad I/O operation.

5.5 Serial Clock (CLK)

This input signal provides the timing for the serial interface. Instructions, addresses, or data present at serial data input are latched on the rising edge of Serial Clock (CLK). Data are shifted out on the falling edge of the Serial Clock (CLK).

6. BLOCK DIAGRAM

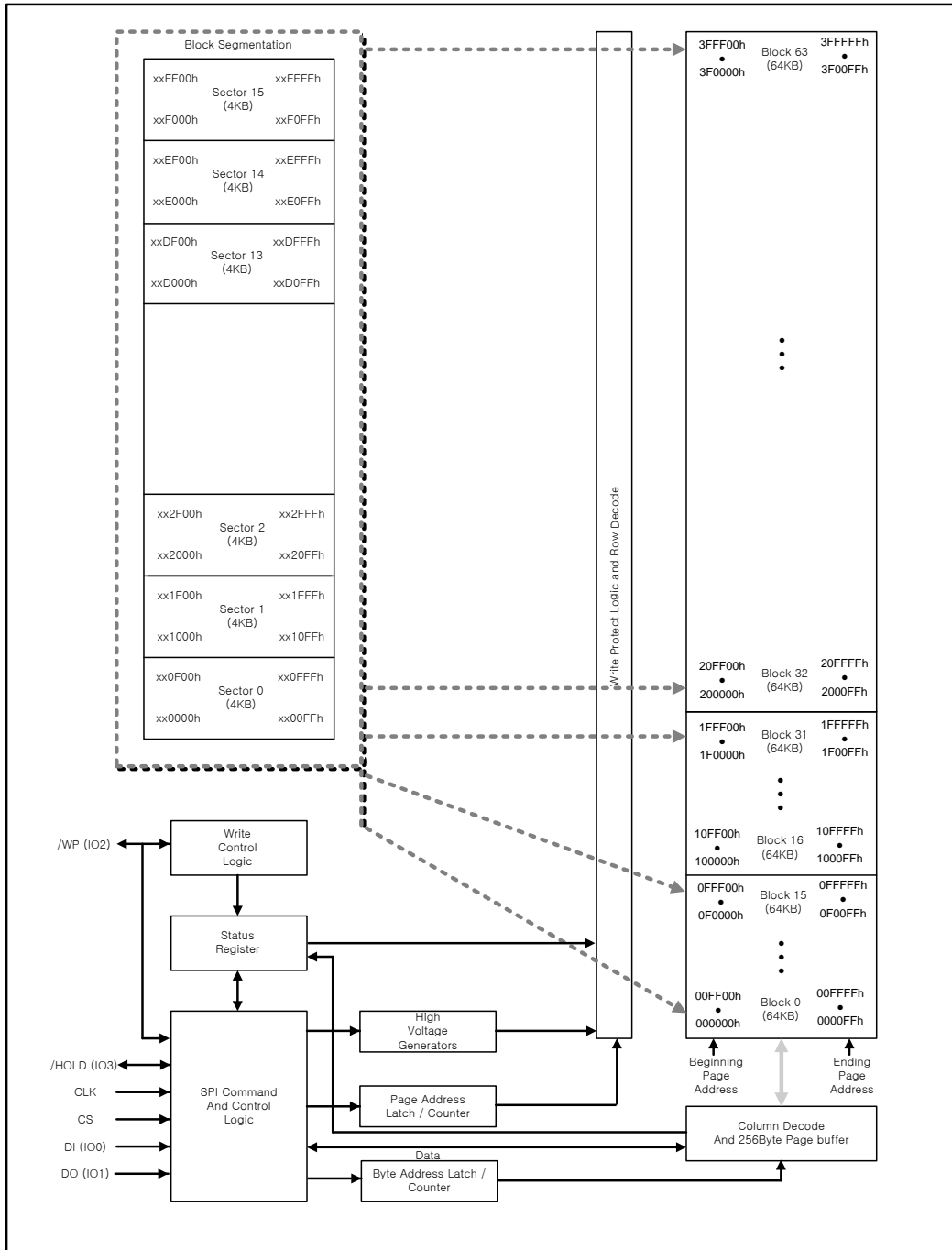

Figure 2. Block Diagram of FM25Q32

7. FUNCTIONAL DESCRIPTION

7.1 Standard SPI Instructions

The FM25Q32 features a serial peripheral interface on four signals: Serial Clock (CLK), Chip Select (/CS), Serial Data Input (DI) and Serial Data Output (DO). Standard SPI instructions use the DI input pin to serially write instructions, addresses or data to the device on the rising edge of CLK. The DO output pin is used to read data or status from the device on the falling edge of CLK.

SPI bus operation Modes 0 (0, 0) and 3 (1, 1) are supported. The primary difference between Mode 0 and Mode 3 concerns the normal state of the CLK signal when the SPI bus master is in standby and data is not being transferred to the Serial Flash. For Mode 0 the CLK signal is normally low on the falling and rising edges of /CS. For Mode 3 the CLK signal is normally high on the falling and rising edges of /CS.

7.2 Dual SPI Instructions

The FM25Q32 supports Dual SPI operation when using the “Fast Read Dual I/O” (BB hex) instruction. This instruction allows data to be transferred to or from the device at two times the rate of the standard SPI. The Dual Read instruction is ideal for quickly downloading code to RAM upon power-up (code-shadowing) or for executing non-speed-critical code directly from the SPI bus (XIP). When using Dual SPI instructions the DI and DO pins become bidirectional I/O pins; IO0 and IO1.

7.3 Quad SPI Instructions

The FM25Q32 supports Quad SPI operation when using the “Fast Read Quad I/O” (EB hex). This instruction allows data to be transferred to or from the device at four times the rate of the standard SPI. The Quad Read instruction offers a significant improvement in continuous and random access transfer rates allowing fast code-shadowing to RAM or execution directly from the SPI bus (XIP). When using Quad SPI instruction the DI and DO pins become bidirectional IO0 and IO1, and the /WP and /HOLD pins become IO2 and IO3 respectively. Quad SPI instructions require the non-volatile Quad Enable bit (QE) in Status Register-2 to be set.

7.4 Hold Function

The /HOLD pin is used to pause a serial sequence of the SPI flash memory without resetting the clocking sequence. To enable the /HOLD mode, the /CS must be in low state. The /HOLD mode effects on with the falling edge of the /HOLD signal with CLK being low. The HOLD mode ends on the rising edge of /HOLD signal with CLK being low.

In other words, /HOLD mode can't be entered unless CLK is low at the falling edge of the /HOLD signal. And /HOLD mode can't be exited unless CLK is low at the rising edge of the /HOLD signal. See Figure.3 for HOLD condition waveform.

If /CS is driven high during a HOLD condition, it resets the internal logic of the device. As long as /HOLD signal is low, the memory remains in the HOLD condition. To re-work communication with the device, /HOLD must go high, and /CS must go low. See 12.11 for HOLD timing.

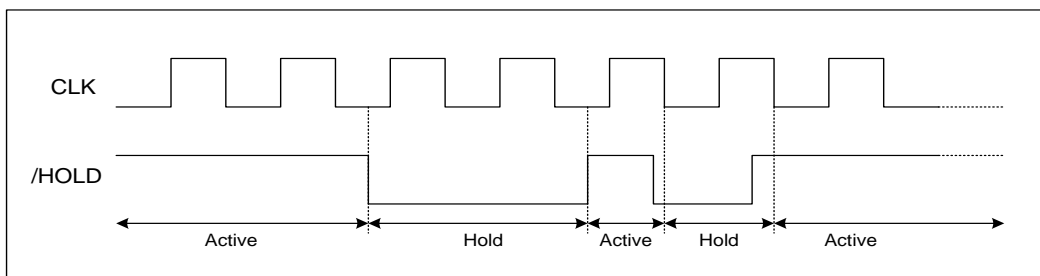

Figure3. Hold condition waveform

8. WRITE PROTECTION

To protect inadvertent writes by the possible noise, several means of protection are applied to the Flash memory.

8.1 Write protect Features

- While Power-on reset, all operations are disabled and no instruction is recognized.
- An internal time delay of tPUW can protect the data against inadvertent changes while the power supply is outside the operating specification. This includes the Write Enable, Page program, Sector Erase, Block Erase, Chip Erase, Write Security Register and the Write Status Register instructions.
- For data changes, Write Enable instruction must be issued to set the Write Enable Latch (WEL) bit to "0". Power-up, Completion of Write Disable, Write Status Register, Page program, Sector Erase, Block Erase and Chip Erase are subjected to this condition.
- Using setting the Status Register protect (SRP) and Block protect (SEC, TB, BP2, BP1, and BP0) bits a portion of memory can be configured as reading only called software protection.
- Write Protect(WP) pin can control to change the Status Register under hardware control.
- The Deep Power Down mode provides extra software protection from unexpected data changes as all instructions are ignored under this status except for Release Deep Power-down instruction.
- One time program(OTP) mode provide protection mode from program/erase operation

9. STATUS REGISTER

The Read Status Register instruction can be used to provide status on the availability of the Flash memory array, if the device is write enabled or disabled, the state of write protection and the Quad SPI setting. The Write Status Register instruction can be used to configure the devices write protection features and Quad SPI setting. Write access to the Status Register is controlled by in some cases of the /WP pin.

S7	S6	S5	S4	S3	S2	S1	S0
SRP0	SEC	TB	BP2	BP1	BP0	WEL	BUSY
Status Register Protect 0 (Non-Volatile)	Sector Protect (Non-Volatile)	Top/Bottom Write Protect (Non-Volatile)	Block Protect (Non-Volatile)	Block Protect (Non-Volatile)	Block Protect (Non-Volatile)	Write Enable Latch	Erase or Write in Progress

Figure 4a. Status Register-1

S15	S14	S13	S12	S11	S10	S9	S8
SUS	(R)	(R)	(R)	(R)	(R)	QE	SRP1
Suspend Status	Reserved	Reserved	Reserved	Reserved	Reserved	Quad Enable (Non-Volatile)	Status Register Protect 1 (Non-Volatile)

Figure 4b. Status Register-2

9.1 BUSY

BUSY is a read only bit in the status register (S0) that is set to a 1 state when the device is executing a Page Program, Sector Erase, Block Erase, Chip Erase or Write Status Register instruction. During this time the device will ignore further instruction except for the Read Status Register and Erase Suspend instruction (see tW, tPP, tSE, tBE1, tBE2 and tCE in AC Characteristics). When the program, erase or write status register instruction has completed, the BUSY bit will be cleared to a 0 state indicating the device is ready for further instructions.

9.2 Write Enable Latch (WEL)

Write Enable Latch (WEL) is a read only bit in the status register (S1) that is set to a 1 after executing a Write Enable instruction. The WEL status bit is cleared to a 0, When device is write disabled. A write disable state occurs upon power-up or after any of the following instructions: Write Disable, Page Program, Sector Erase, Block Erase, Chip Erase and Write Status Register.

9.3 Block Protect Bits (BP2, BP1, BP0)

The Block Protect Bits (BP2, BP1, BP0) are non-volatile read/write bits in the status register (S4, S3, and S2) that provide write protection control and status. Block protect bits can be set using the Write Status Register Instruction (see tW in AC characteristics). All none or a portion of the memory array can be protected from Program and Erase instructions (see Status Register Memory Protection table). The factory default setting for the Block Protection Bits is 0, none of the array protected.

9.4 Top/Bottom Block protect (TB)

The non-volatile Top/Bottom bit (TB) controls if the Block Protect Bits (BP2, BP1, BP0) protect from the Top (TB=0) or the Bottom (TB=1) of the array as shown in the Status Register Memory Protection table. The factory default setting is TB=0. The TB bit can be set with the Write Status Register Instruction depending on the state of the SRP0, SRP1 and WEL bits.

9.5 Sector/Block Protect (SEC)

The non-volatile Sector protect bit (SEC) controls if the Block Protect Bits (BP2, BP1, BP0) protect 4KB Sectors (SEC=1) or 64KB Blocks (SEC=0) in the Top (TB=0) or the Bottom (TB=1) of the array as shown in the Status Register Memory protection table. The default setting is SEC=0.

9.6 Status Register protect (SRP1, SRP0)

The Status Register Protect bits (SRP1 and SRP0) are non-volatile read/write bits in the status register (S8 and S7). The SRP bits control the method of write protection: software protection, hardware protection, power supply lock-down or one time programmable (OTP) protection.

SRP1	SRP0	/WP	Status Register	Description
0	0	X	Software Protection	/WP pin no control. The register can be written to after a Write Enable instruction, WEL=1. [Factory Default]
0	1	0	Hardware Protected	When /WP pin is low the Status Register locked and can not be written to.
0	1	1	Hardware Unprotected	When /WP pin is high the Status register is unlocked and can be written to after a Write Enable instruction, WEL=1
1	0	X	Power Supply Lock-Down	Status Register is protected and can not be written to again until the next power-down, power-up cycle ⁽¹⁾ .
1	1	X	One Time Program	Status Register is permanently protected and can not be written to.

Note:

1. When SRP1, SRP0=(1,0), a power-down, power-up cycle will change SRP1, SRP0 to(0,0) state.

9.7 Erase/Program Suspend Status (SUS)

The Suspend Status bit is a read only bit in the status register (S15) that is set to 1 after executing an Erase/Program Suspend (75h) instruction. The SUS status bit is cleared to 0 by Erase/Program Resume (7Ah) instruction as well as a power-down, power-up cycle.

9.8 Quad Enable (QE)

The Quad Enable (QE) bit is a non-volatile read/write bit in the status register (S9) that allows Quad operation. When the QE bit is set to a 0 state (factory default) the /WP pin and /Hold are enabled. When the QE pin is set to a 1 the Quad IO2 and IO3 pins are enabled.

WARNING : The QE bit should never be set to a 1 during standard SPI or Dual SPI operation if the /WP or /HOLD pins are tied directly to the power supply or ground.

9.9 Status Register Memory Protection

STATUS REGISTER ⁽¹⁾					MEMORY PROTECTION			
SEC	TB	BP2	BP1	BP0	BLOCK(S)	ADDRESSES	DENSITY	PORTION
X	X	0	0	0	NONE	NONE	NONE	NONE
0	0	0	0	1	63	3F0000h-3FFFFFFh	64KB	Upper 1/64
0	0	0	1	0	62 and 63	3E0000h-3FFFFFFh	128KB	Upper 1/32
0	0	0	1	1	60 thru 63	3C0000h-3FFFFFFh	256KB	Upper 1/16
0	0	1	0	0	56 thru 63	380000h-3FFFFFFh	512KB	Upper 1/8
0	0	1	0	1	48 thru 63	300000h-3FFFFFFh	1MB	Upper 1/4
0	0	1	1	0	32 thru 63	200000h-3FFFFFFh	2MB	Upper 1/2
0	1	0	0	1	0	000000h-0FFFFFFh	64KB	Lower 1/64
0	1	0	1	0	0 and 1	000000h-01FFFFh	128KB	Lower 1/32
0	1	0	1	1	0 thru 3	000000h-03FFFFh	256KB	Lower 1/16
0	1	1	0	0	0 thru 7	000000h-07FFFFh	512KB	Lower 1/8
0	1	1	0	1	0 thru 15	000000h-0FFFFFFh	1MB	Lower 1/4
0	1	1	1	0	0 thru 31	000000h-1FFFFFFh	2MB	Lower 1/2
X	X	1	1	1	0 thru 63	000000h-3FFFFFFh	4MB	ALL
1	0	0	0	1	63	3FF000h-3FFFFFFh	4KB	Top Block
1	0	0	1	0	63	3FE000h-3FFFFFFh	8KB	Top Block
1	0	0	1	1	63	3FC000h-3FFFFFFh	16KB	Top Block
1	0	1	0	X	63	3F8000h-3FFFFFFh	32KB	Top Block
1	1	0	0	1	0	000000h-000FFFh	4KB	Bottom Block
1	1	0	1	0	0	000000h-001FFFh	8KB	Bottom Block
1	1	0	1	1	0	000000h-003FFFh	16KB	Bottom Block
1	1	1	0	X	0	000000h-007FFFh	32KB	Bottom Block

Note :

1. X = don't care

10. INSTRUCTIONS

The instruction set of the FM25Q32 consists of fifteen basic instructions that are fully controlled through the SPI bus (see Instruction Set table). Instructions are initiated with the falling edge of Chip Select (/CS). The first byte of data clocked into the DI input provides the instruction code. Data on the DI input is sampled on the rising edge of clock with most significant bit (MSB) first.

Instructions vary in length from a single byte to several bytes and may be followed by address bytes, data bytes, dummy bytes (don't care), and in some cases, a combination. Instructions are completed with the rising edge of edge /CS. Clock relative timing diagrams for each instruction are included in figures 4 through 35. All read instructions can be completed after any clocked bit. However, all instructions that Write, Program or Erase must complete on a byte (/CS driven high after a full 8-bit have been clocked) otherwise the instruction will be terminated. This feature further protects the device from inadvertent writes. Additionally, while the memory is being programmed or erased, or when the Status Register is being written, all instructions except for Read Register will be ignored until the program or erase cycle has completed.

10.1 Manufacturer and Device Identification

		ID code	Instruction
Manufacturer ID	Fidelix Semiconductor	F8h	90h, EFh, DFh, 9Fh
Device ID	FM25Q32	15h	90h, EFh, DFh, ABh
Memory Type ID	SPI	32h	9Fh
Capacity Type ID	32M	16h	9Fh

10.2 Instruction Set Table 1⁽¹⁾

INSTRUCTION NAME	BYTE 1 (CODE)	BYTE 2	BYTE 3	BYTE 4	BYTE 5	BYTE 6
Write Enable	06h					
Write Enable for Volatile Status Register	50h					
Write Disable	04h					
Read Status Register-1	05h	(S7-S0) ⁽²⁾				
Read Status Register-2	35h	(S15-S8) ⁽²⁾				
Write Status Register	01h	(S7-S0)	(S15-S8)			
Page Program	02h	A23-A16	A15-A8	A7-A0	(D7-D0)	
Quad Data Input Page Program ⁽³⁾	32h	A23-A16	A15-A8	A7-A0	(D7-D0, ...) ³	
Quad Page Program	38h	A23-A0, (D7-D0)	A15-A8	A7-A0	(D7-D0, ...) ³	
Block Erase (64KB)	D8h	A23-A16	A15-A8	A7-A0		
Block Erase (32KB)	52h	A23-A16	A15-A8	A7-A0		
Sector Erase (4KB)	20h	A23-A16	A15-A8	A7-A0		
Chip Erase	C7h/60h					
Erase/Program Suspend	75h					
Erase/Program Resume	7Ah					
Deep Power-down	B9h					
Mode Bit Reset ⁽⁴⁾	FFh					
Release Deep power-down/ Device ID	ABh	dummy	dummy	dummy	(ID7-ID0) ⁽⁵⁾	
Read Manufacturer/ Device ID ⁽⁶⁾	90h	dummy	dummy	00h or 01h	(M7-M0)	(ID7-ID0)
Read Dual Manufacturer/ Device ID ⁽⁶⁾	EFh	dummy	dummy	00h or 01h	(M7-M0) (ID7-ID0)	
Read Quad Manufacturer/ Device ID ⁽⁶⁾	DFh	dummy	dummy	00h or 01h	(M7-M0...) (ID7-ID0...)	
Read SFDP Register	5Ah	00h	00h	A7-A0	dummy	(D7-D0)
Write Security Register	2Fh					
Read Security Register	2Bh	(S7-S0)				
Enter Secured OTP	B1h					
Exit Secured OTP	C1h					
Read JEDEC ID	9Fh	(M7-M0) Manufacturer	(ID7-ID0) Memory Type	(ID7-ID0) Capacity		

Notes:

1. Data bytes are shifted with Most Significant Bit first. Byte fields with data in parenthesis “()” indicate data being read from the device on the IO pin.

2. The Status Register contents will repeat continuously until /CS terminates the instruction.
3. Quad Data Input Page Program Input Data
 IO0 = (D4, D0 ...)
 IO1 = (D5, D1 ...)
 IO2 = (D6, D2 ...)
 IO3 = (D7, D3 ...)
4. This instruction is recommended when using the Dual or Quad Mode bit feature. See section 10.2.28 for more information.
5. The Device ID will repeat continuously until /CS terminates the instruction.
6. See Manufacturer and Device Identification table for Device ID information.

10.3 Instruction Set Table 2 (Read Instructions)

INSTRUCTION NAME	BYTE 1 (CODE)	BYTE 2	BYTE 3	BYTE 4	BYTE 5	BYTE 6
Read Data	03h	A23-A16	A15-A8	A7-A0	(D7-D0)	
Fast Read Data	0Bh	A23-A16	A15-A8	A7-A0	dummy	(D7-D0)
Fast Read Dual Output	3Bh	A23-A16	A15-A8	A7-A0	dummy	(D7-D0, ...) ⁽¹⁾
Fast Read Quad Output	6Bh	A23-A16	A15-A8	A7-A0	dummy	(D7-D0, ...) ⁽³⁾
Fast Read Dual I/O	BBh	A23-A8 ⁽²⁾	A7-A0, M7-M0 ⁽²⁾	(D7-D0, ...) ⁽¹⁾		
Fast Read Quad I/O	EBh	A23-A0, M7-M0 ⁽⁴⁾	(x,x,x,x, D7-D0,...) ⁽⁵⁾	(D7-D0, ...) ⁽³⁾		
Set Burst with Wrap	77h	xxxxxx, W6-W4 ⁽⁴⁾				

Notes:

1: Dual Output data

IO0 = (D6, D4, D2, D0)
 IO1 = (D7, D5, D3, D1)

2: Dual Input Address

IO0 = A22, A20, A18, A16, A14, A12, A10, A8, A6, A4, A2, A0, M6, M4, M2, M0
 IO1 = A23, A21, A19, A17, A15, A13, A11, A9, A7, A5, A3, A1, M7, M5, M3, M1

3: Quad Output Data

IO0 = (D4, D0...)
 IO1 = (D5, D1...)
 IO2 = (D6, D2...)
 IO3 = (D7, D3...)

4: Quad Input Address

IO0 = A20, A16, A12, A8, A4, A0, M4, M0
 IO1 = A21, A17, A13, A9, A5, A1, M5, M1
 IO2 = A22, A18, A14, A10, A6, A2, M6, M2
 IO3 = A23, A19, A15, A11, A7, A3, M7, M3

Set Burst with Wrap Input

IO0 = x, x, x, x, x, x, W4, x
 IO1 = x, x, x, x, x, x, W5, x
 IO2 = x, x, x, x, x, x, W6, x
 IO3 = x, x, x, x, x, x, x, x

5: Fast Read Quad I/O Data

IO0 = (x, x, x, x, D4, D0...)
 IO1 = (x, x, x, x, D5, D1...)
 IO2 = (x, x, x, x, D6, D2...)
 IO3 = (x, x, x, x, D7, D3...)

10.4 Write Enable (06h)

Write Enable instruction is for setting the Write Enable Latch (WEL) bit in the Status Register. The WEL bit must be set prior to every Program, Erase and Write Status Register instruction. To enter the Write Enable instruction, /CS goes low prior to the instruction "06h" into Data Input (DI) pin on the rising edge of CLK, and then driving /CS high.

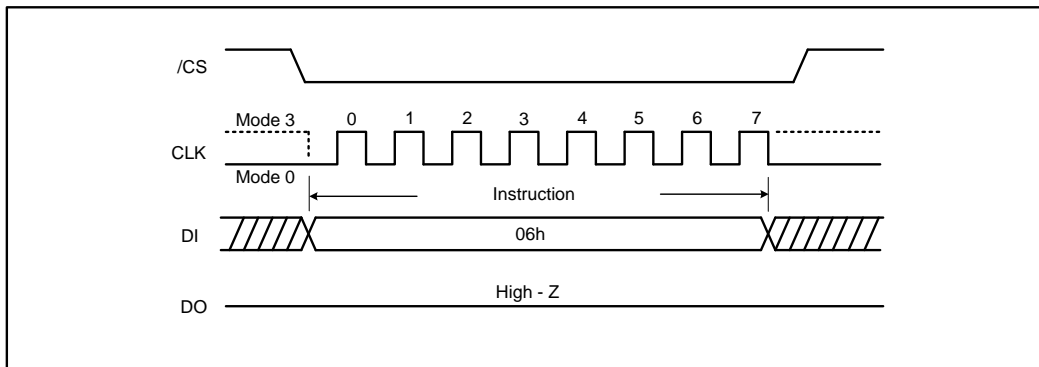

Figure 5. Write Enable Instruction Sequence Diagram

10.5 Write Enable for Volatile Status Register (50h)

This gives more flexibility to change the system configuration and memory protection schemes quickly without waiting for the typical non-volatile bit write cycles or affecting the endurance of the Status Register non-volatile bits. To write the volatile values into the Status Register bits, the Write Enable for Volatile Status Register (50h) instruction must be issued prior to a Write Status Register (01h) instruction. Write Enable for Volatile Status Register instruction (Figure 6) will not set the Write Enable Latch (WEL) bit, it is only valid for the Write Status Register instruction to change the volatile Status Register bit values

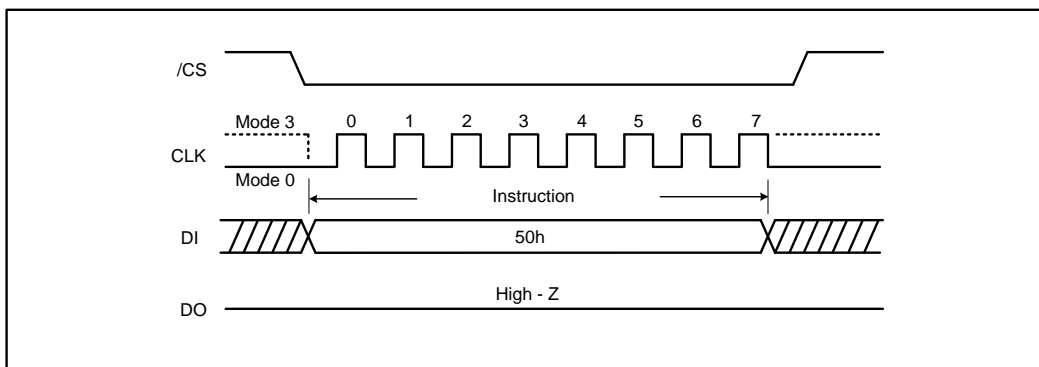

Figure 6. Write Enable for Volatile Status Register Instruction Sequence Diagram

10.6 Write Disable (04h)

The Write Disable instruction is to reset the Write Enable Latch (WEL) bit in the Status Register. The Write Disable instruction is entered by driving /CS low, sending the instruction code “04h” into the DI pin and then driving /CS high. WEL bit is automatically reset write-disable status of “0” after Power-up and upon completion of the every Program, Erase and Write Status Register instructions.

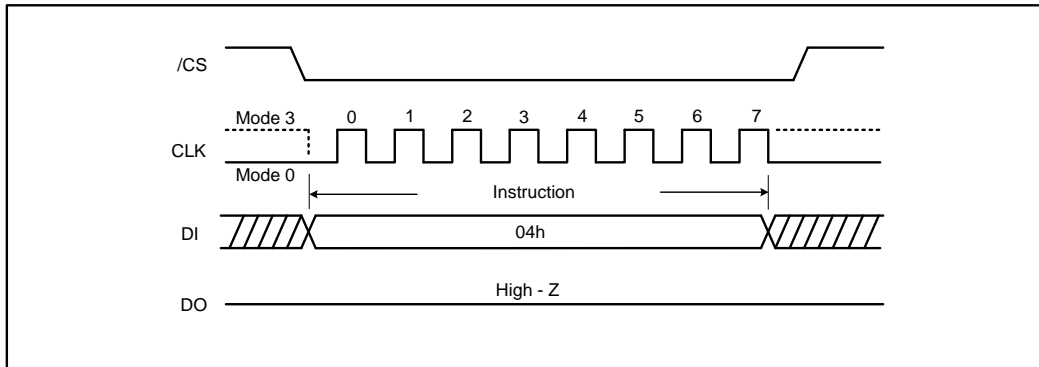

Figure 7. Write Disable Instruction Sequence Diagram

10.7 Read Status Register-1 (05h) and Read Status Register-2 (35h)

The Read Status Register instructions are to read the Status Register. The Read Status Register can be read at any time (every Program, Erase, Write Status Register and Write Security Register cycle is in progress). It is recommended to check the BUSY bit before sending a new instruction when a Program, Erase, Write Status Register or Write Status Register operation is in progress.

The instruction is entered by driving /CS low and sending the instruction code “05h” for Status Register-1 or “35h” for Status Register-2 into the DI pin on the rising edge of CLK. The status register bits are then shifted out on the DO pin at the falling edge of CLK with most significant bit (MSB) first as shown in (figure 7). The Status Register bits are shown in figure 4a and 4b include the BUSY, WEL, BP2-BP0, TB, SEC, SRP0, SRP1 and QE bits (see description of the Status Register earlier in this datasheet).

The Status Register can be read continuously, as shown in (Figure 7). The instruction is completed by driving /CS high.

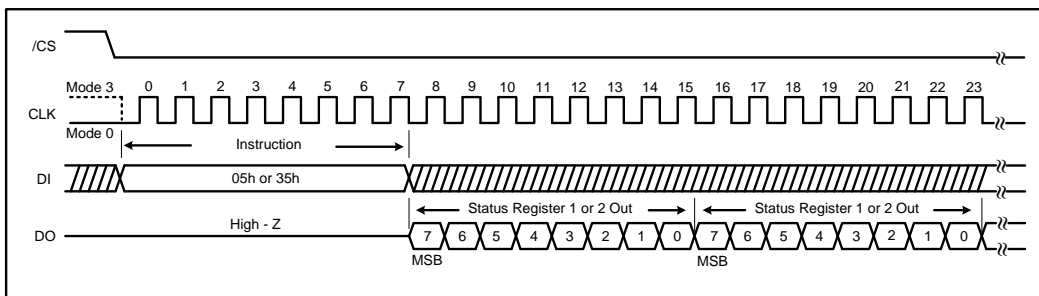

Figure 8. Read Status Register Instruction Sequence Diagram

10.8 Write Status Register (01h)

The Write Status Register instruction is to write the Status Register. A Write Enable instruction must previously have been issued prior to setting Write Status Register Instruction (Status Register bit WEL must equal 1). Once write is enabled, the instruction is entered by driving /CS low, sending the instruction code "01h", and then writing the status register data byte or word as illustrated in figure 9. The Status Register bits are shown in figure 4 and described earlier in this datasheet.

Only non-volatile Status Register bits SRP0, SEC, TB, BP2, BP1, BP0 (bits 7, 5, 4, 3, 2 of Status Register-1) and QE, SRP1 (bits 9 and 8 of Status Register-2) can be written to. All other Status Register bit locations are read-only and will not be affected by the Write Status Register instruction.

The /CS pin must be driven high after the eighth or sixteenth bit of data that is clocked in. If this is not done the Write Status Register instruction will not be executed. If /CS is driven high after the eighth clock, the QE and SRP1 bits will be cleared to 0. After /CS is driven high, the self-timed Write Status Register cycle will commence for a time duration of t_w (See AC Characteristics). While the Write Status Register cycle is in progress, the Read Status Register instruction may still be accessed to check the status of the BUSY bit. The BUSY bit is a 1 during the Write Status Register cycle and a 0 when the cycle is finished and ready to accept other instructions again. After the Write Status Register cycle has finished, The Write Enable Latch (WEL) bit in Status Register will be cleared to 0.

The Write Status Register instruction can change the value of Block Protect bits (SEC, TB, BP2, BP1 and BP0) to define the protected area of memory from erase and program instructions. Protected areas become read-only (see Status Register Memory Protection table and description). The Write Status Register instruction also allows the Status Register Protect bits (SRP0, SRP1) to be set. Those bits are used in conjunction with the Write protect (/WP) pin, Lock out or OTP features to disable writes to the status register. Please refer to 9 for detailed descriptions Status Register protection methods. Factory default all Status Register bits are 0.

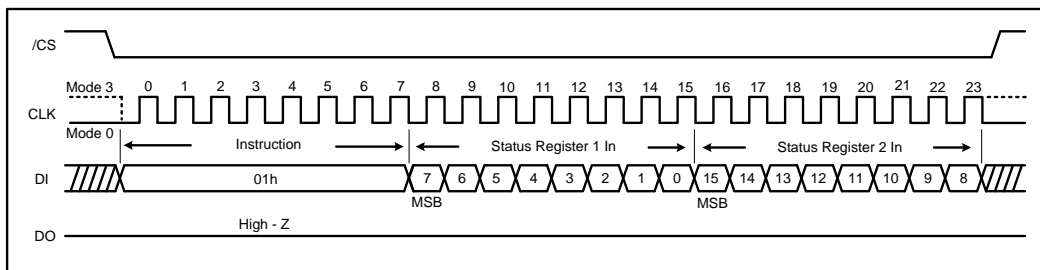

Figure 9. Write Status Register Instruction Sequence Diagram

10.9 Read Data (03h)

The Read Data instruction is to read data out from the device. The instruction is initiated by driving the /CS pin low and then sending the instruction code “03h” with following a 24-bit address (A23-A0) into the DI pin. The code and address bits are latched on the rising edge of the CLK pin. After the address is received, the data byte of the addressed memory location will be shifted out on the DO pin at the falling edge of CLK with most significant bit (MSB) first. The address is automatically incremented to the next higher address after byte of data is shifted out allowing for a continuous stream of data. This means that the entire memory can be accessed with a single instruction as long as the clock continues. The instruction is completed by driving /CS high. The Read Data instruction sequence is shown in (figure 10). If a Read Data instruction is issued while an Erase, Program or Write Status Register cycle is in process (BUSY=1) the instruction is ignored and will not have any effects on the current cycle. The Read Data instruction allows clock rates from D.C to a maximum of f_R (see AC Electrical Characteristics).

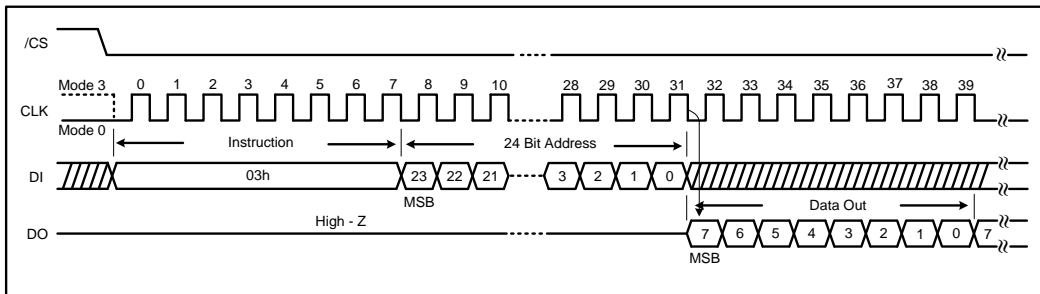

Figure 10. Read Data Register Instruction Sequence Diagram

10.10 Fast Read (0Bh)

The Fast Read instruction is high speed reading mode. The address is latched on the rising edge of the CLK. After the 24-bit address, this is accomplished by adding eight “dummy” clocks as shown in (figure 11). The dummy clocks means the internal circuits require time to set up the initial address. During the dummy clocks, the data value on the DO pin is a “don’t care”. Data of each bit shifts out on the falling edge of CLK.

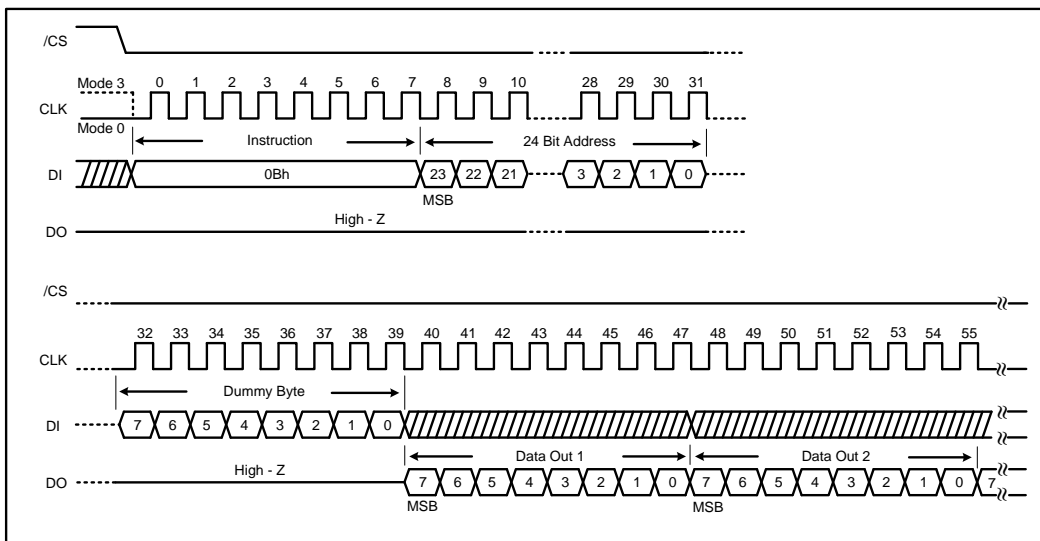

Figure 11. Fast Read Register Instruction Sequence Diagram

10.11 Fast Read Dual Output (3Bh)

The Fast Read Dual Output instruction enable double throughput of Serial Flash in read mode. This instruction is similar to the standard Fast Read (0Bh) instruction except that data is output on two pins: IO₀ and IO₁, instead of just IO₀. This allows data to be transferred from the FM25Q32 at twice the rate of standard SPI devices. The Fast Read Dual Output instruction is ideal for quickly downloading code from Flash to RAM upon power-up or for application that cache code-segments to RAM for execution.

The Fast Read Dual Output instruction can operate at the highest possible frequency of F_R (see AC Electrical Characteristics). After the 24-bit address, this is accomplished by adding eight “dummy” clocks as shown in (figure 12). The dummy clocks allow the internal circuits additional time for setting up the initial address. During the dummy clocks, the data value on the DO pin is a “don’t care”. However, the IO₀ pin should be high-impedance prior to the falling edge of the first data out clock.

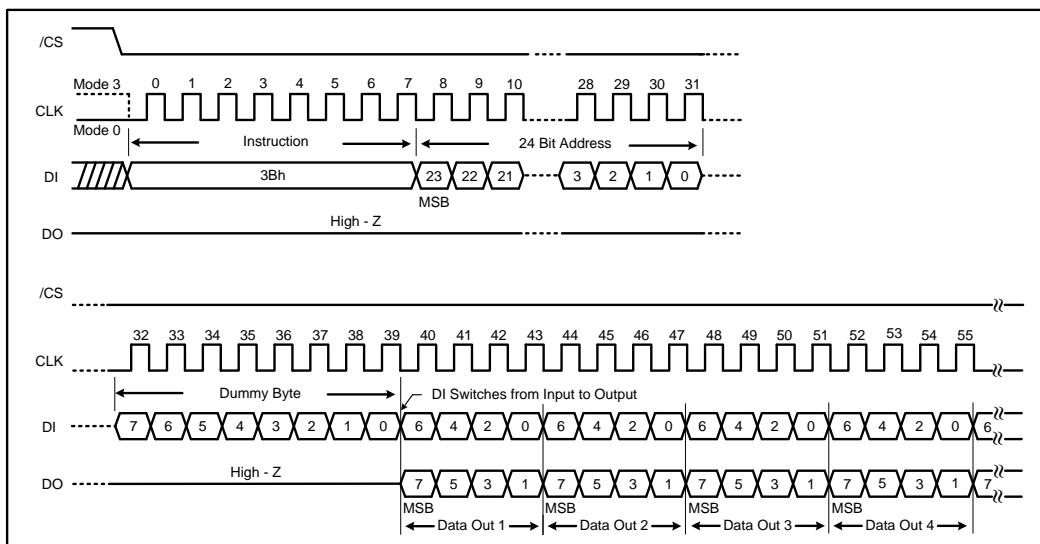

Figure 12. Fast Read Dual Output Instruction Sequence Diagram

10.12 Fast Read Quad Output (6Bh)

The Fast Read Dual Output instruction enable quad throughput of Serial Flash in read mode. The Fast Read Quad Output instruction is similar to the Fast Read Dual Output (3Bh) instruction except that data is output on four pins: IO₀, IO₁, IO₂, and IO₃. A Quad enable of Status Register-2 must be executed before the device will accept the Fast Read Quad Output instruction (Status Register bit QE must equal 1). The Fast Read Quad Output instruction allows data to be transferred from the FM25Q32 at four times the rate of standard SPI devices.

The Fast Read Dual Output instruction can operate at the highest possible frequency of F_R (see AC Electrical Characteristics). This is accomplished by adding eight “dummy” clocks after the 24-bit address as shown in (figure 13). The dummy clocks allow the internal circuits additional time for setting up the initial address. During the dummy clocks, the data value on the DO pin is a “don’t care”. However, the IO₀ pin should be high-impedance prior to the falling edge of the first data out clock.

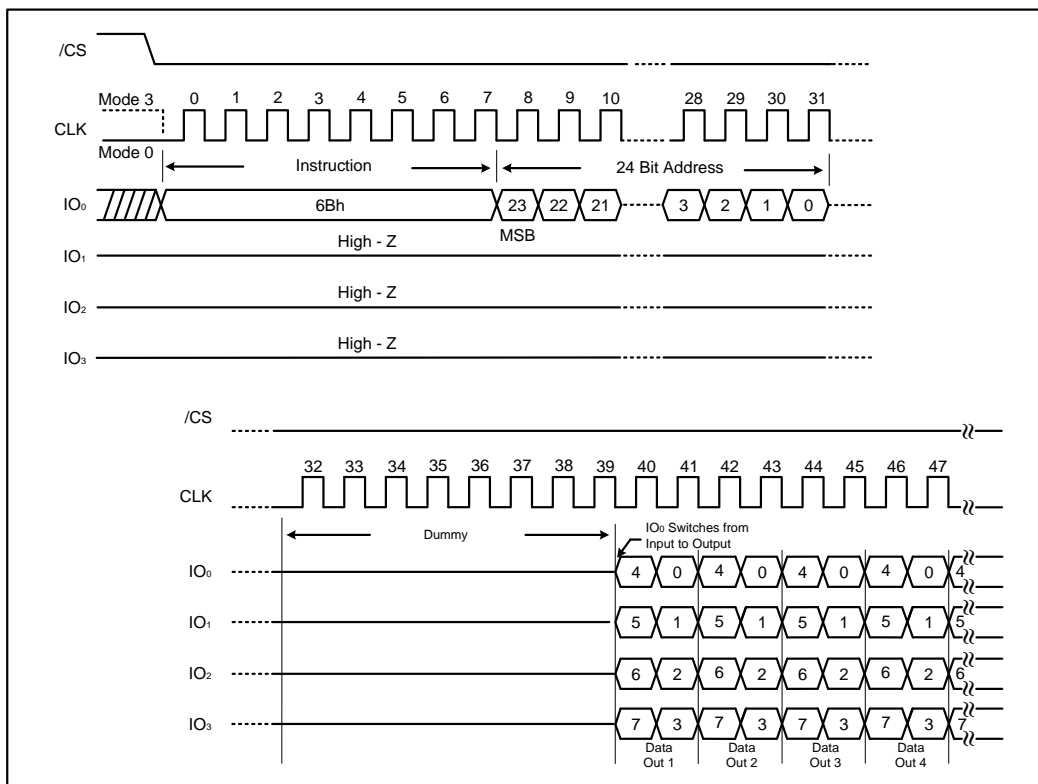

Figure 13. Fast Read Quad Output Instruction Sequence Diagram

10.13 Fast Read Dual I/O (BBh)

The Fast Read Dual I/O instruction reduce cycle overhead through double access using two IO pins, IO₀ and IO₁.

“Continuous read mode”

The Fast Read Dual I/O instruction can further reduce instruction overhead through setting the Mode bits (M7-0) after the input Address bits (A23-0), as shown in (figure 14a). The upper nibble of the Mode (M7-4) controls the length of the next Fast Read Dual I/O instruction through the inclusion or exclusion of the first byte instruction code. The lower nibble bits of the Mode (M3-0) are don't care (“X”), However, the IO pins should be high-impedance prior to the falling edge of the first data out clock.

If the Mode bits (M7-0) equal “Ax” hex, then the next Fast Dual I/O instruction (after /CS is raised and then lowered) does not require the BBh instruction code, as shown in (figure 14b). This reduces the instruction sequence by eight clocks and allows the address to be immediately entered after /CS is asserted low. If Mode bits (M7-0) are any value other “Ax” hex, the next instruction (after /CS is raised and then lowered) requires the first byte instruction code, thus returning to normal operation. A Mode Bit Reset instruction can be used to reset Mode Bits (M7-0) before issuing normal instructions.

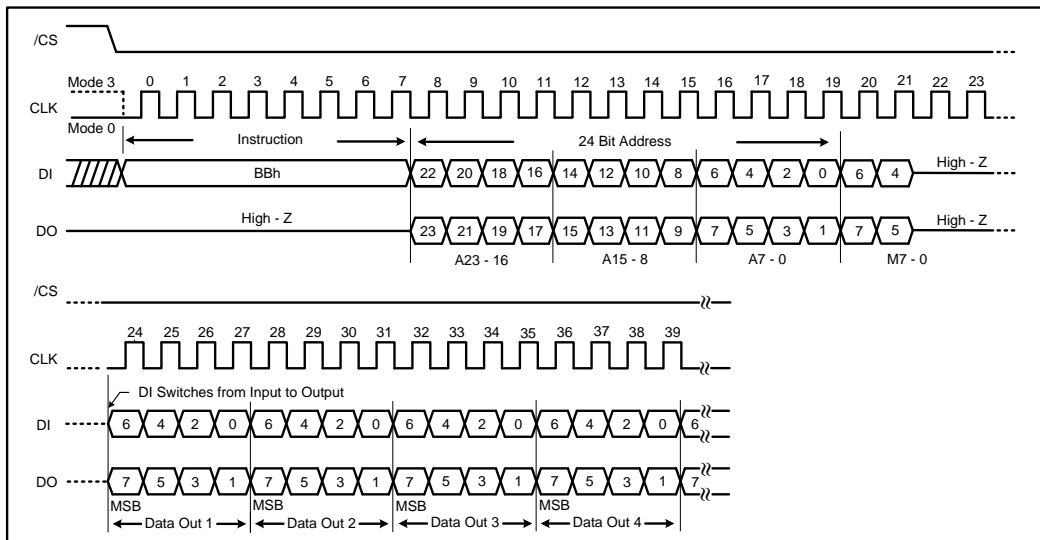

Figure 14a. Fast Read Dual Input/Output Instruction Sequence Diagram (M7-0 = 0xh or NOT Axh)

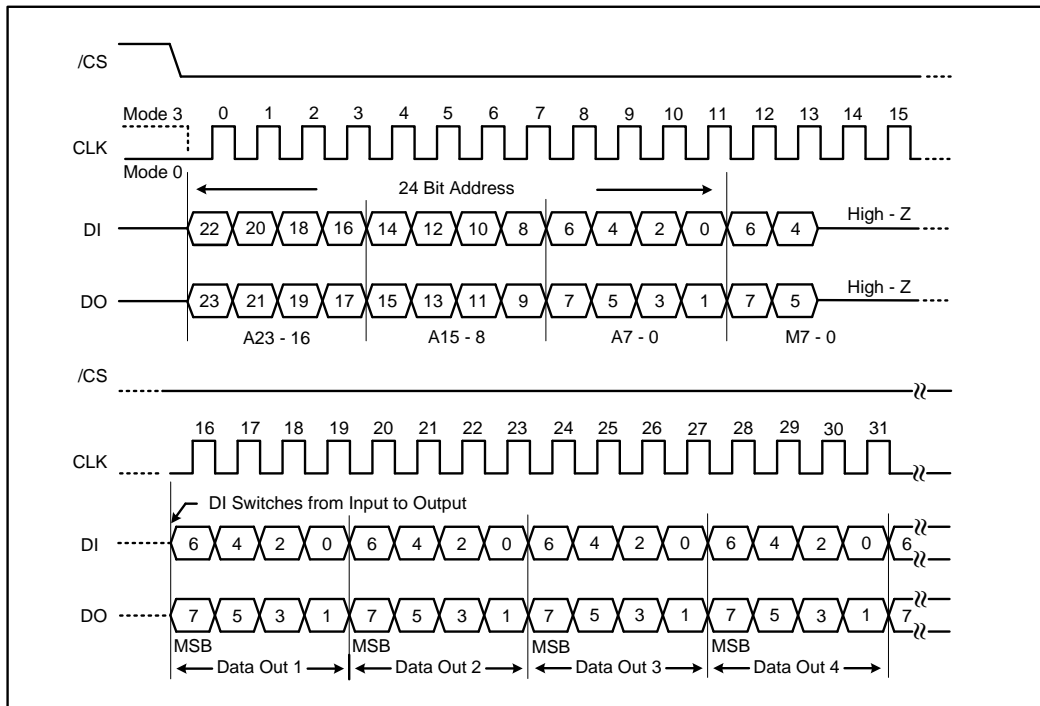

Figure 14b. Fast Read Dual Input/Output Instruction Sequence Diagram (M7-0 = Axh)

10.14 Fast Read Quad I/O (EBh)

The Fast Read Quad I/O instruction is similar to the Fast Read Dual I/O instruction but with the capability to input the 24 bit address, mode bits through four pins IO₀, IO₁, IO₂, and IO₃ and four Dummy clock are required prior to the data output. The Quad I/O drastically eliminate instruction cycle and makes faster random access for code executing (XIP) directly from the Quad SPI. The Quad Enable bit (QE) of Status Register-2 must be set to enable the Fast read Quad I/O Instruction.

“Continuous read mode”

The Fast Read Quad I/O instruction can further reduce instruction overhead through setting the Mode bits (M7-0) with following the input Address bits (A23-0), as shown in (figure 15a). The upper nibble of the Mode (M7-4) controls the length of the next Fast Read Quad I/O instruction through the inclusion or exclusion of the first byte instruction code. The lower nibble bits of the Mode (M3-0) are don't care (“X”). However, the IO pins should be high-impedance prior to the falling edge of the first data out clock.

If the Mode bits (M7-0) equal “Ax” hex, then the next Fast Read Quad I/O instruction (after /CS is raised and then lowered) does not require the EBh instruction code, as shown in (figure 15b). This reduces the instruction sequence by eight clocks and allows the address to be immediately entered after /CS is asserted low. If the Mode bits (M7-0) are any value other than “Ax” hex, the next instruction (after /CS is raised and then lowered) requires the first byte instruction code, thus retuning normal operation. A Mode Bit Reset can be used to reset Mode Bits (M7-0) before issuing normal instructions.

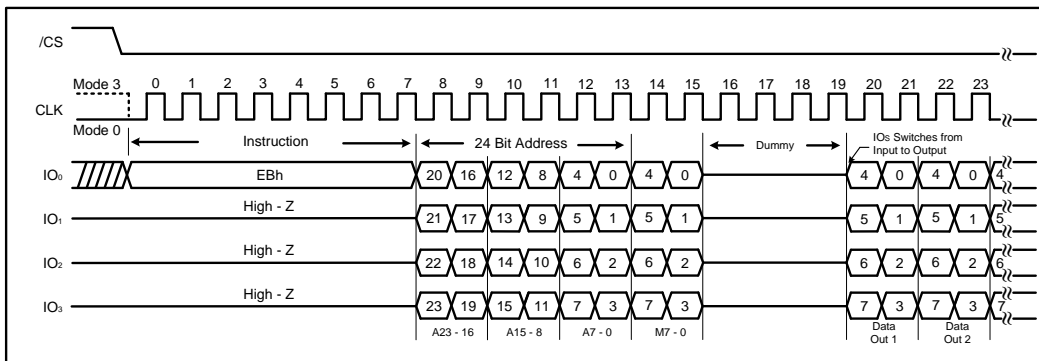

Figure 15a. Fast Read Quad Input/Output Instruction Sequence Diagram (M7-0 = 0xh or NOT Axh)

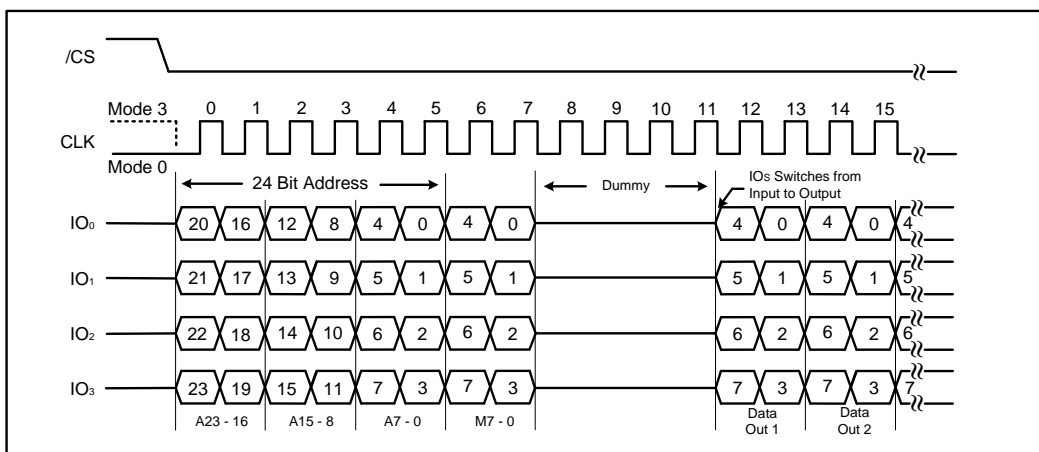

Figure 15b. Fast Read Quad Input/Output Instruction Sequence Diagram (M7-0 = Axh)

10.15 Page Program (02h)

The Page Program instruction is for programming the memory to be “0”. A Write Enable instruction must be issued before the device accept the Page Program Instruction (Status Register bit WEL= 1). After the Write Enable (WREN) instruction has been decoded, the device sets the Write Enable Latch (WEL). The instruction is entered by driving the /CS pin low and then shifting the instruction code “02h” with following a 24-bits address (A23-A0) and at least one data byte, into the DI pin. The /CS pin must be driven low for the entire time of the instruction while data is being sent to the device. (Please refer to figure 16).

If the entire 256 data bytes are going to be programmed, A7-A0 (the eight least significant address bits) should be set to 0. If more than 256 bytes are sent the device, previously latched data are discarded and the last 256 data bytes are guaranteed to be programmed correctly within the same page. If less than 256 data bytes are sent t device, they are correctly programmed at the requested addresses without having any effects on the other bytes of the same page.

The /CS pin must be driven high after the eighth bit of the last byte has been latched in, otherwise the Page Program instruction is not executed. After /CS is driven high, the self-timed Page Program instruction will commence for a duration of tPP (See AC Characteristics). While the Page Program cycle is in progress, the Read Status Register instruction may still be accessed for checking the status of the BUSY bit. The BUSY bit is a 1 during the Page Program cycle and becomes a 0 when the cycle is finished and the device is ready to accept other instructions again. After the Page Program cycle has finished and Write Enable Latch (WEL) bit in the Status Register is cleared to 0. The Page Program instruction applied to a page which is protected by the Block Protect (SEC, TB, BP2, BP1, and BP0) bits is not executed.

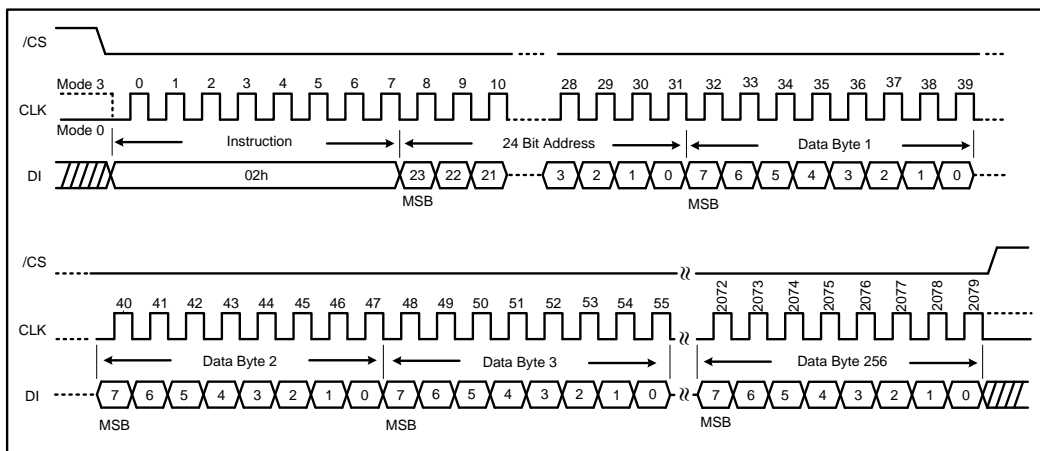

Figure 16. Page Program Instruction Sequence Diagram

10.16 Quad Data Input Page Program (32h)

The Quad Data Input Page Program instruction is to program the memory as being “0” at previously erased (FFh) memory areas. The Quad Data Input Page Program takes four pins: IO₀, IO₁, IO₂ and IO₃ as data input, which can improve programmer performance and the effectiveness of application of lower clock less than 5MHz. System using faster clock speed will not get more benefit for the Quad Data Input Page Program as the required internal page program time is far more than the time data clock-in.

To use Quad Data Input Page Program the Quad Enable in Status Register-2 must be set (QE=1), A Write Enable instruction must be executed before the device will accept the Quad Data Input Page Program instruction (Status Register-1, WEL=1). The instruction is initiated by driving the /CS pin low and then shifting the instruction code “32h” with following a 24-bit address (A23-A0) and at least one data, into the IO pins. The /CS pin must be held low for the entire length of the instruction while data is being sent to the device. All other functions of Quad Data Input Page Program are perfectly same as standard Page Program. (Please refer to figure 17).

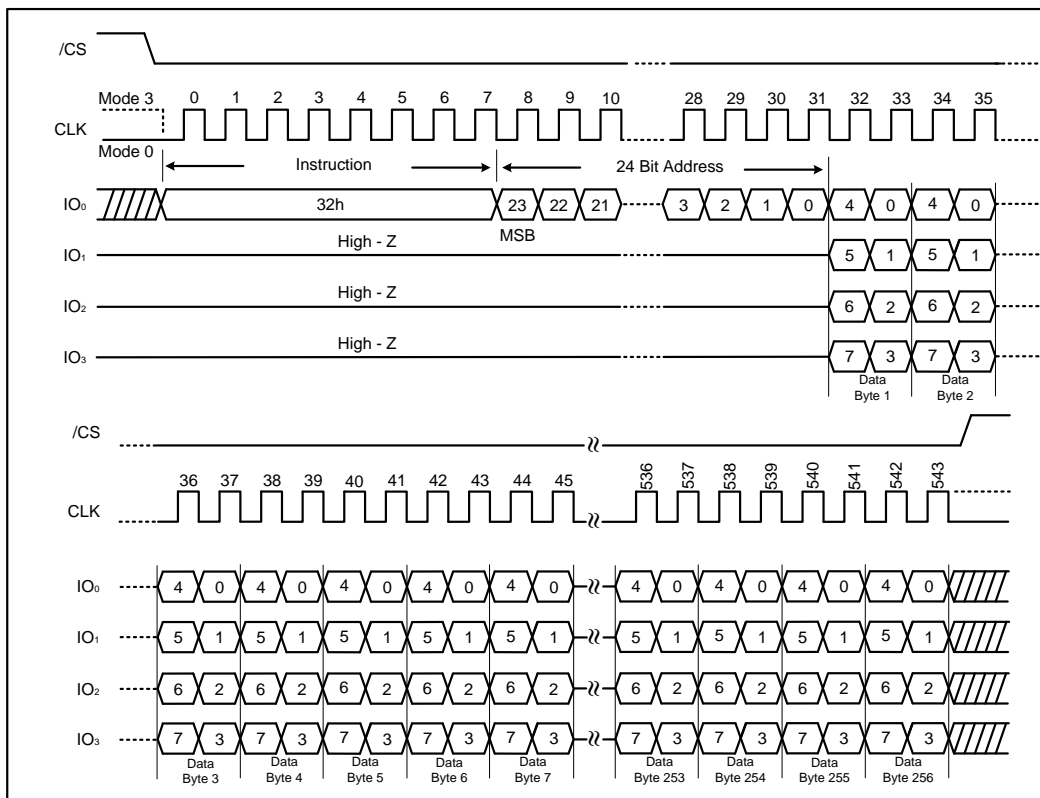

Figure 17. Quad Data Input Page Program Instruction Sequence Diagram

10.17 Quad Page Program (38h)

The Quad Data Input Page Program instruction is to program the memory as being “0” at previously erased (FFh) memory areas. The Quad Data Input Page Program takes four pins: IO₀, IO₁, IO₂ and IO₃ as address and data input, which can improve programmer performance and the effectiveness of application of lower clock less than 5MHz. System using faster clock speed will not get more benefit for the Quad Data Input Page Program as the required internal page program time is far more than the time data clock-in.

To use Quad Data Input Page Program the Quad Enable in Status Register-2 must be set (QE=1), A Write Enable instruction must be executed before the device will accept the Quad Data Input Page Program instruction (Status Register-1, WEL=1). The instruction is initiated by driving the /CS pin low then shifting the instruction code “38h” with following a 24-bit address (A23-A0) and at least one data, into the IO pins. The /CS pin must be held low for the entire length of the instruction while data is being sent to the device. All other functions of Quad Page Program are perfectly same as standard Page Program. (Please refer to figure 18).

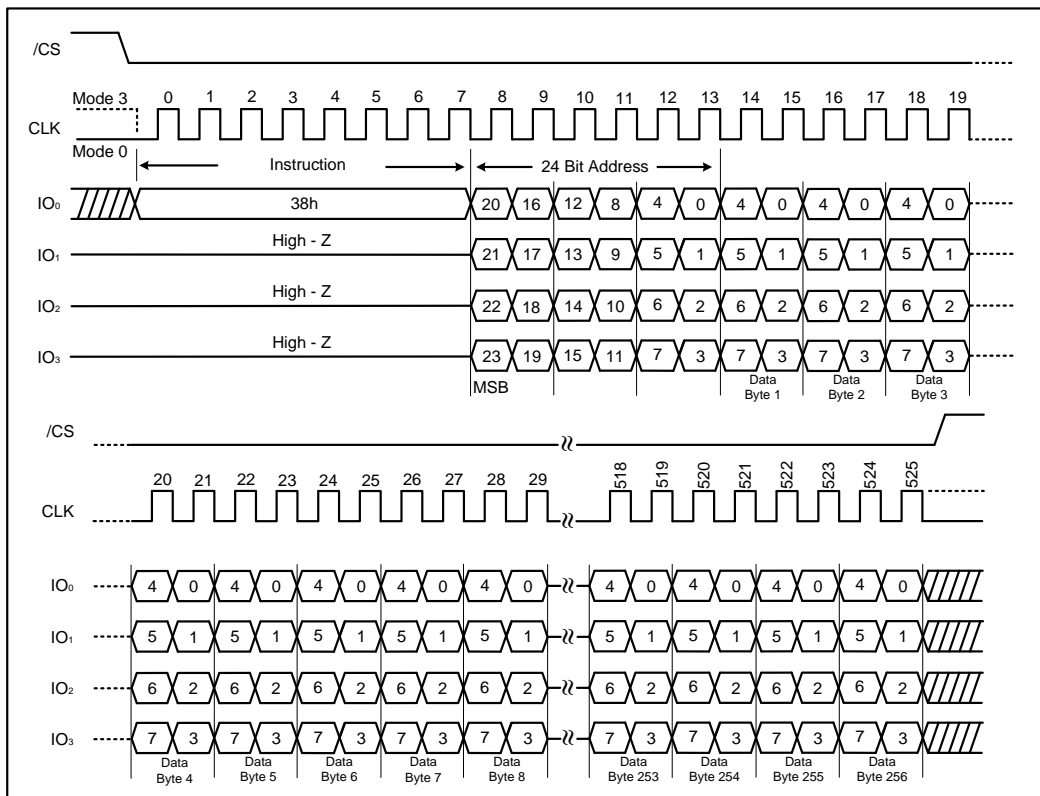

Figure 18. Quad Page Program Instruction Sequence Diagram

10.18 Sector Erase (20h)

The Sector Erase instruction is to erase the data of the selected sector as being “1”. The instruction is used for an 4K-byte sector. Prior to the Sector Erase Instruction, a Write Enable instruction must be issued. (Status Register bit WEL must be equal to 1). The instruction is initiated by driving the /CS pin low and shifting the instruction code “20h” followed a 24-bit sector address (A23-A0). (Please refer to figure 19).

The /CS pin must be driven high after the eighth bit of the last byte has been latched in, otherwise the Sector Erase instruction will not be executed. After /CS is driven high, the self-timed Sector Erase instruction will commence for a time duration of tSE (See AC Characteristics). While the Sector Erase cycle is in progress, the Read Status Register instruction may still be accessed for checking the status of the BUSY bit. The BUSY bit is a 1 during the Sector Erase cycle and becomes a 0 when the cycle is finished and the device is ready to accept other instructions again. After the Sector Erase cycle has finished the Write Enable Latch (WEL) bit in Status Register is cleared to 0. The Sector Erase instruction applied to addressed page which is protected by the Block Protect (SEC, TB, BP2, BP1, and BP0) bits is not executed. (see Status Register Memory protection table).

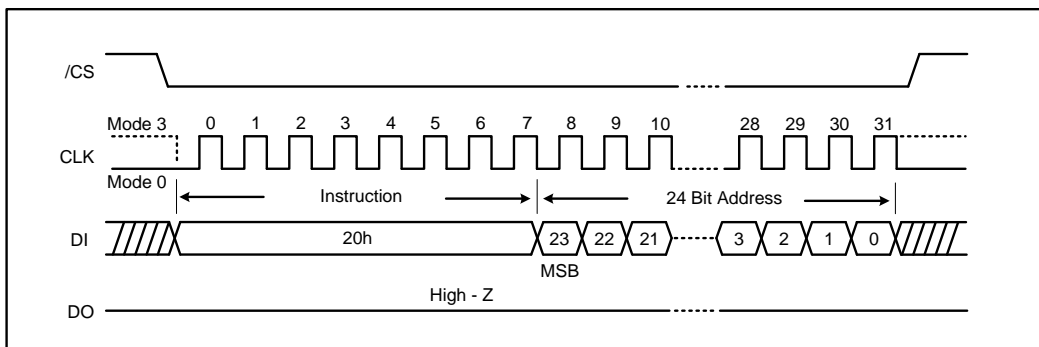

Figure 19. Sector Erase Instruction Sequence Diagram

10.19 32KB Block Erase (52h)

The Block Erase instruction is to erase the data of the selected block as being “1”. The instruction is used for an 32K-byte Block erase operation. Prior to the Block Erase Instruction, a Write Enable instruction must be issued. (Status Register bit WEL must equal 1). The instruction is initiated by driving the /CS pin low and shifting the instruction code “52h” followed a 24-bit block address (A23-A0). (Please refer to figure 20).

The /CS pin must be driven high after the eighth bit of the last byte has been latched in, otherwise the Block Erase instruction will not be issued. After /CS is driven high, the self-timed Block Erase instruction will commence for a time duration of tBE1 (See AC Characteristics). While the Block Erase cycle is in progress, the Read Status Register instruction may still be accessed for checking the status of the BUSY bit. The BUSY bit is a 1 during the Block Erase cycle and becomes a 0 when the cycle is finished and the device is ready to accept other instructions again.

After the Sector Erase cycle has finished the Write Enable Latch (WEL) bit in Status Register is cleared to 0. The Block Erase instruction applied to addressed page which is protected by the Block Protect (SEC, TB, BP2, BP1, and BP0) bits is not executed. (see Status Register Memory Protection table).

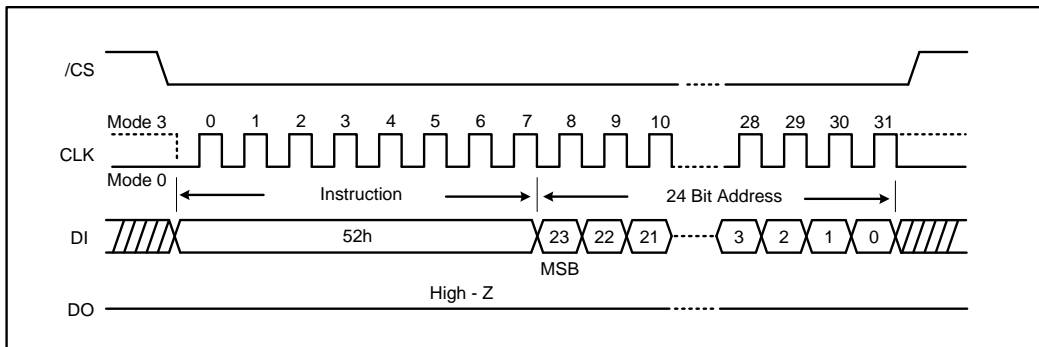

Figure 20. 32KB Block Erase Instruction Sequence Diagram

10.20 64KB Block Erase (D8h)

The Block Erase instruction is to erase the data of the selected block as being “1”. Prior to the Block Erase Instruction, a Write Enable instruction must be issued. (Status Register bit WEL must equal 1). The instruction is initiated by driving the /CS pin low and shifting the instruction code “D8h” followed a 24-bit block address (A23-A0). (Please refer to figure 21).

The /CS pin must be driven high after the eighth bit of the last byte has been latched. If this is not done the Block Erase instruction will not be executed. After /CS is driven high, the self-timed Block Erase instruction will commence for a time duration of tBE1 (See AC Characteristics). While the Block Erase cycle is in progress, the Read Status Register instruction may still be accessed for checking the status of the BUSY bit. The BUSY bit is a 1 during the Block Erase cycle and becomes a 0 when the cycle is finished and the device is ready to accept other instructions again. After the Block Erase cycle has finished the Write Enable Latch (WEL) bit in the Status Register is cleared to 0. The Block Erase instruction applied to addressed page which is protected by the Block Protect (SEC, TB, BP2, BP1, and BP0) bits is not executed. (see Status Register Memory Protection table).

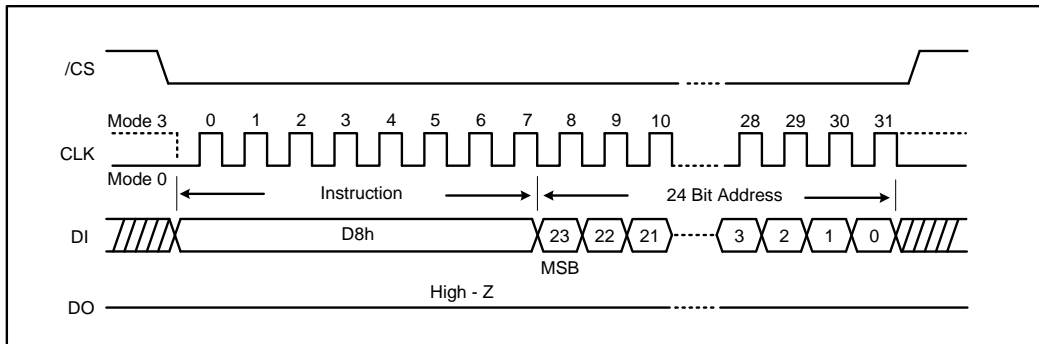

Figure 21. 64KB Block Erase Instruction Sequence Diagram

10.21 Chip Erase (C7h / 60h)

The Chip-Erase instruction clears all bits in the device to be FFh (all 1s). A Chip-Erase instruction will be ignored if any of the memory area is protected. Prior to any Write operation, the Write-Enable (WREN) instruction must be executed. The instruction is initiated by driving the /CS pin low and shifting the instruction code “C7h” or “60h”. (Please refer to figure 22).

The /CS pin must be driven high after the eighth bit has been latched. If this is not done the Chip Erase instruction will not be executed. After /CS is driven high, the self-timed Chip Erase instruction will commence for a duration of tCE (See AC Characteristics). While the Chip Erase cycle is in progress, the Read Status Register instruction may still be accessed to check the status of the BUSY bit. The BUSY bit is a 1 during the Chip Erase cycle and becomes a 0 when the cycle is finished and the device is ready to accept other instructions again. After the Chip Erase cycle has finished the Write Enable Latch (WEL) bit in the Status Register is cleared to 0. The Chip Erase instruction applied to a page which is protected by the Block Protect (SEC, TB, BP2, BP1, and BP0) bits is not executed. (see Status Register Memory Protection table).

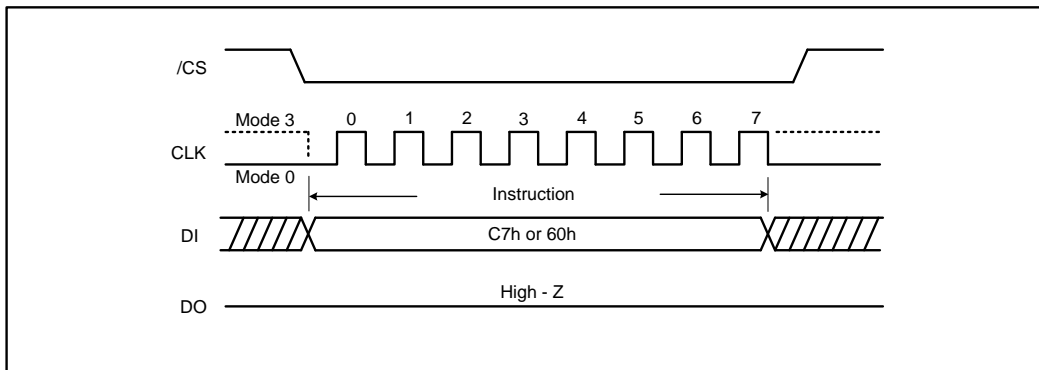

Figure 22. Chip Erase Instruction Sequence Diagram

10.22 Erase / Program Suspend (75h)

The Erase/Program Suspend instruction “75h”, allows the system to interrupt a Sector or Block Erase operation or a Page Program operation and then conduct other operation. (Please refer to figure 23).

The Write Status Register instruction (01h) and Erase instructions (20h, 52h, D8h, C7h, 60h) are not allowed during Erase Suspend. Erase Suspend is valid only during the Sector or Block erase operation. If written during the Chip Erase operation, the Erase Suspend instruction is ignored. The Write Status Register instruction (01h) and Program instructions (02h, 32h, 38h) are not allowed during Program Suspend.

The Erase/Program Suspend instruction “75h” will be accepted by the device only if the SUS bit in the Status Register equals to 0 and the BUSY bit equals to 1 while a Sector or Block Erase or a Page Program operation is on-going. If the SUS bit equals to 1 or the BUSY bit equals to 0, the Suspend instruction will be ignored by the device. A maximum of time of “tSUS” (See AC Characteristics) is required to suspend the erase or program operation. The BUSY bit in the Status Register will be cleared from 1 to 0 within “tSUS” and the SUS bit in the Status Register will be set from 0 to 1 immediately after Erase/Program Suspend. For a previously resumed Erase/Program operation, it is also required that the Suspend instruction “75h” is not issued earlier than a minimum of time of “tSUS” following the preceding Resume instruction “7Ah”.

Unexpected power off during the Erase/Program suspend state will reset the device and release the suspend state. SUS bit in the Status Register will also reset to 0. The data within the page, sector or block that was being suspended may become corrupted. It is recommended for the user to implement system design techniques against the accidental power interruption and preserve data integrity during erase/program suspend state.

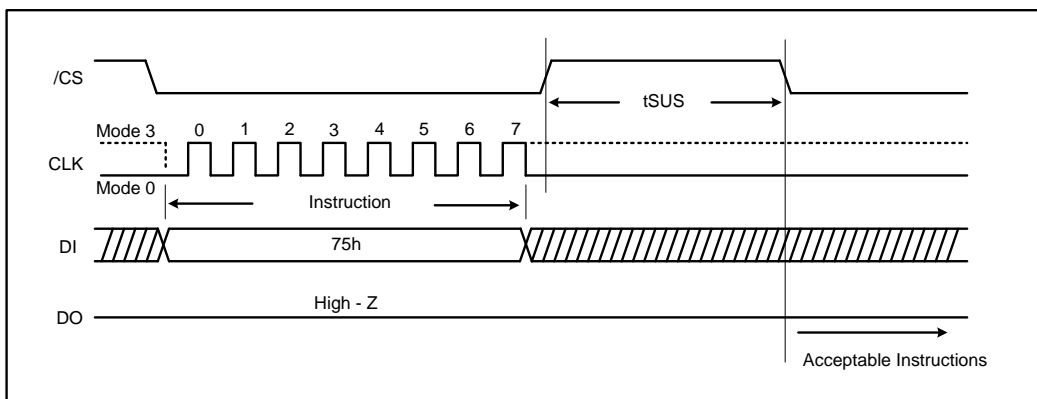

Figure 23. Erase Suspend instruction Sequence

10.23 Erase / Program Resume (7Ah)

The Erase/Program Resume instruction “7Ah” is to re-work the Sector or Block Erase operation or the Page Program operation upon an Erase/Program Suspend. The Resume instruction “7Ah” will be accepted by the device only if the SUS bit in the Status Register equals to 1 and the BUSY bit equals to 0. After issued, the SUS bit will be cleared from 1 to 0 immediately, the BUSY bit will be set from 0 to 1 within 200ns and the Sector or Block will complete the erase operation or the page will complete the program operation. If the SUS bit equals to 0 or the BUSY bit equals to 1, the Resume instruction “7Ah” will be ignored by the device.

Resume instruction can not be accepted if the previous Erase/Program Suspend operation was interrupted by unexpected power off. It is also required that a subsequent Erase/Program Suspend instruction not to be issued within a minimum of time of “tSUS” following a previous Resume instruction. (Please refer to figure 24).

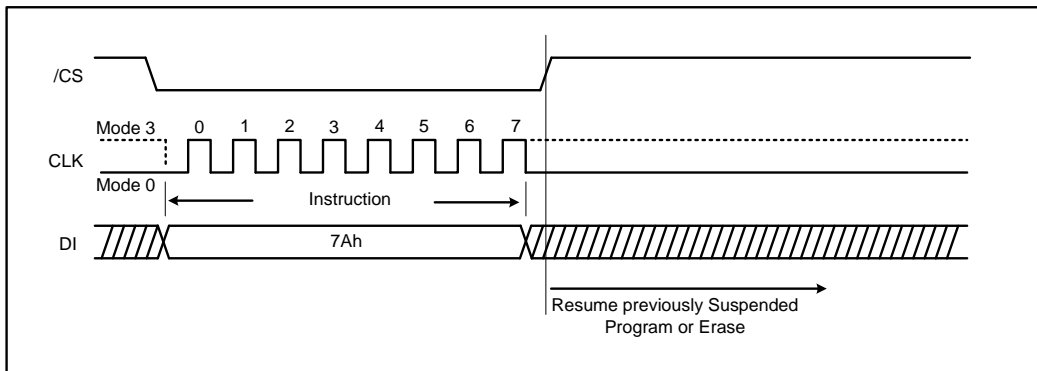

Figure 24. Erase / Program Resume instruction Sequence

10.24 Deep Power-down (B9h)

Executing the Deep Power-down instruction is the best way to put the device in the lowest power consumption. The Deep Power-down instruction reduces the standby current (from ICC1 to ICC2, as specified in AC characteristics). The instruction is entered by driving the /CS pin low with following the instruction code "B9h". (Please refer to figure 25).

The /CS pin must go high once the eighth bit of the instruction code has been latched in, otherwise the Deep Power-down instruction is not executed. After /CS is driven high, it requires a delay of t_{DP} and the Deep power down mode is entered. While in the Release Deep Power-down /Device ID instruction, which restores the device to normal operation, will be recognized. All other instructions are ignored including the Read Status Register instruction, which is always available during normal operation. Deep Power Down Mode automatically stops at Power-Down, and the device always Power-up in the Standby Mode.

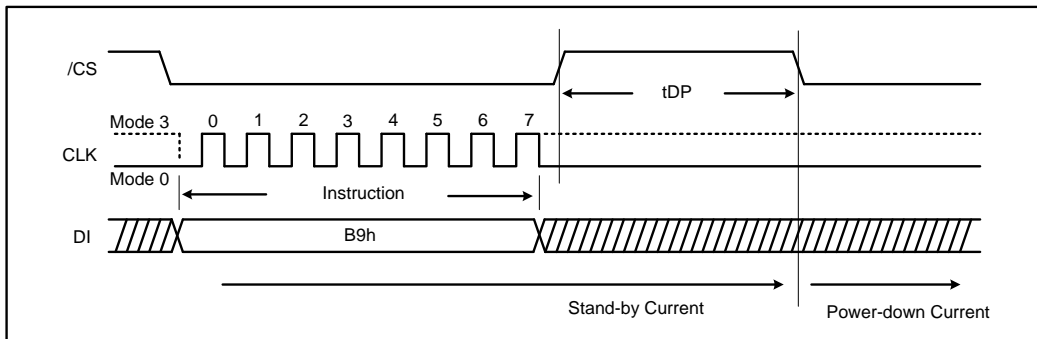

Figure 25. Deep Power-down Instruction Sequence Diagram

10.25 Release Deep Power-down / Device ID (ABh)

The Release from Deep Power-down / Device ID instruction is a multi-purpose instruction. It can be used to release the device from the Deep Power-down state or obtain the device electronic identification (ID) number.

To release the device from the Deep Power-down state, the instruction is issued by driving the /CS pin low, sending the instruction code “ABh” and driving /CS high as shown in figure 26a. Release from Deep Power-down require the time duration of tRES1 (See AC Characteristics) for re-work a normal operation and accepting other instructions. The /CS pin must keep high during the tRES1 time duration.

When used only to obtain the Device ID while not in the Deep Power-down state, instruction is initiated by driving the /CS pin low and sending the instruction code “ABh” with following 3-dummy bytes. The Device ID bits are then shifted on the falling edge of CLK with most significant bit (MSB) first as shown in figure 26b. The Device ID value for the FM25Q32 is listed in Manufacturer and Device Identification table. The Device ID can be read continuously. The instruction is completed by driving /CS high.

When used to release the device from the Deep Power-down state and obtain the Device ID, the instruction is the same as previously described, and shown in figure 26b, except that after /CS is driven high it must keep high for a time duration of tRES2 (See AC Characteristics). After this time duration the device will resume normal operation and other instructions can be accepted. If the Release from Deep Power-down /Device ID instruction is issued while an Erase, Program or Write cycle is in process (when BUSY equals 1) the instruction is ignored and will not have any effects on the current cycle.

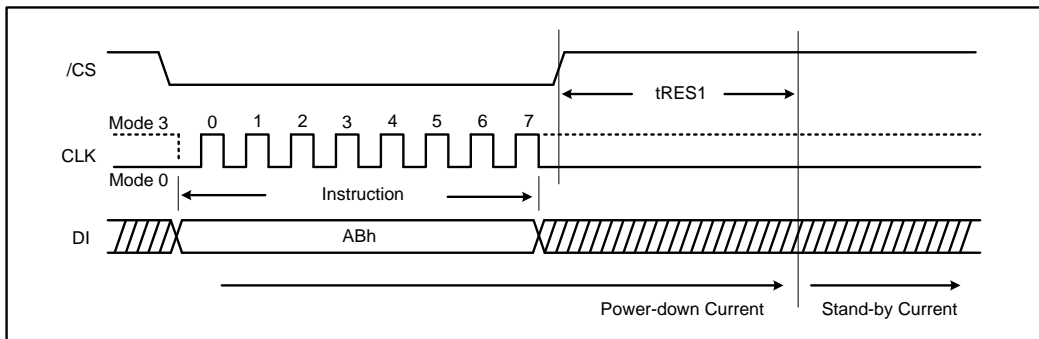

Figure 26a. Release Deep Power-down Instruction Sequence

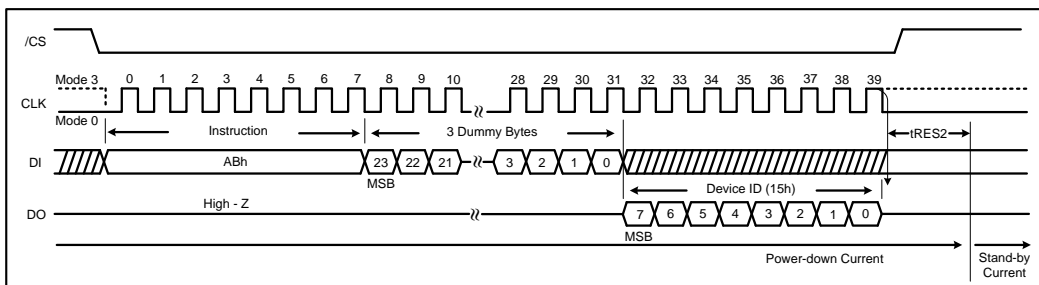

Figure 26b. Release Deep Power-down / Device ID Instruction Sequence Diagram

10.26 Read Manufacturer/ Device ID (90h), (EFh), (DFh)

The Read Manufacturer/ Device ID instruction is an alternative to the Release from Deep Power-down / Device ID instruction that provides both the JEDEC assigned manufacturer ID and the specific device ID.

The Read Manufacturer/ Device ID instruction is very similar to the Release from Deep Power-down / Device ID instruction. The instruction is initiated by driving the /CS pin low and shifting the instruction code “90h” with following a 24-bit address (A23-A0) of 000000h. The instruction code of “EFh” is used for Dual I/O and the instruction code of “DFh” is used for Quad I/O with same instruction sequence. After then, the Manufacturer ID for FIDELIX (F8h) and the Device ID are shifted out on the falling edge of CLK with most significant bit(MSB) first as shown in figure 27a, 27b or 27c. The Device ID value for the FM25Q32 is listed in Manufacturer and Device Identification table. If the 24-bit address is initially set to 000001h the Device ID will be read first with following the Manufacturer ID. The Manufacturer and Device IDs can be read continuously, alternating from one to the other. The instruction is completed by driving /CS high.

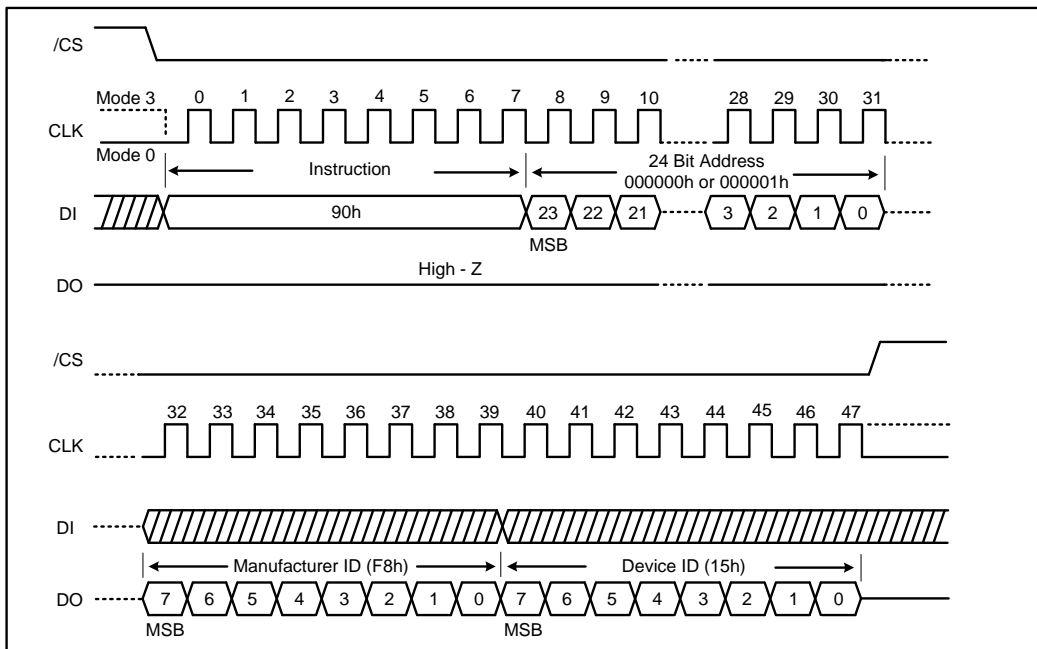

Figure 27a. Read Manufacturer/ Device ID Diagram

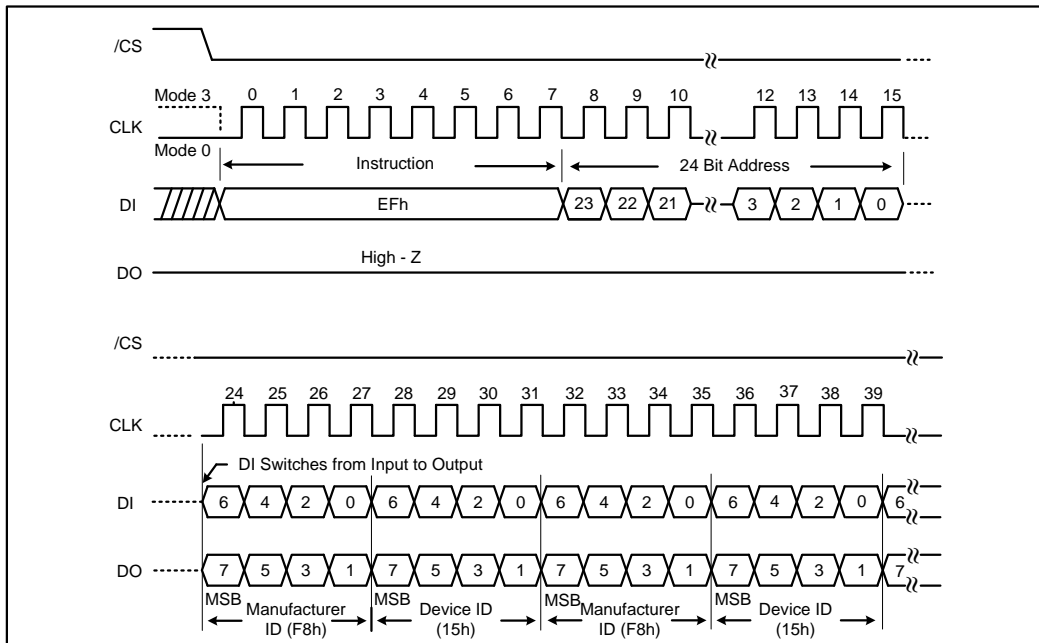

Figure 27b. Read Dual Manufacturer/ Device ID Diagram

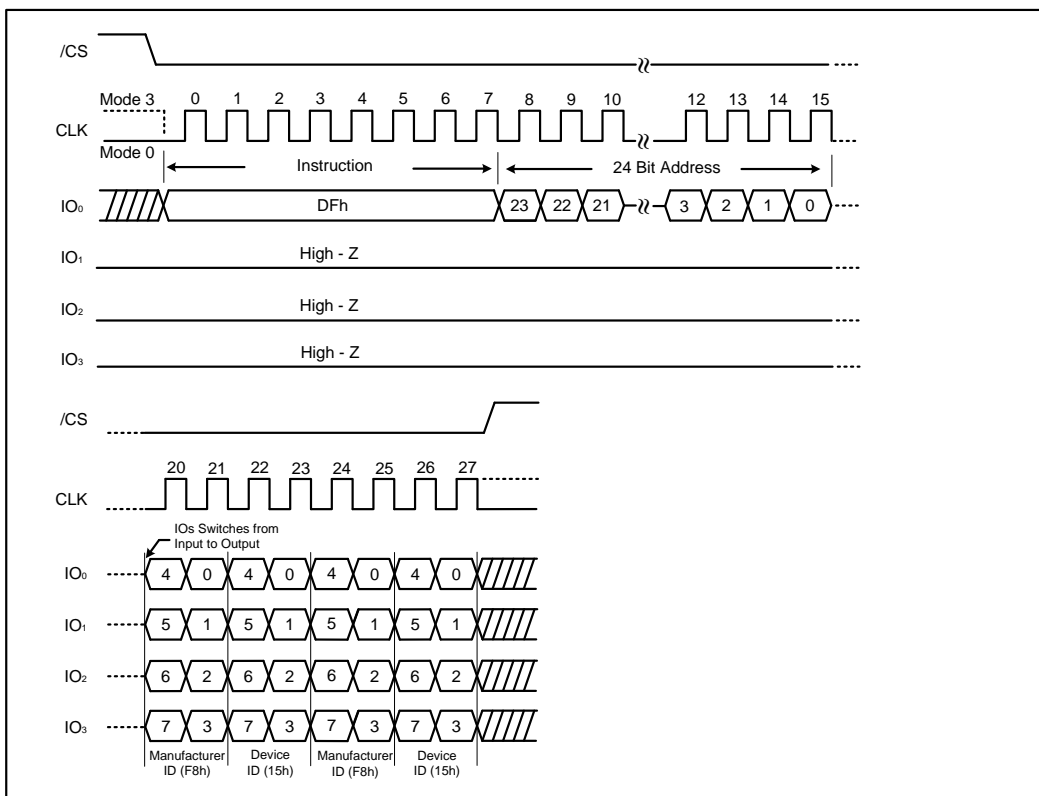

Figure 27c. Read Quad Manufacturer/ Device ID Diagram

10.27 JEDEC ID (9Fh)

For compatibility reasons, the FM25Q32 provides several instructions to electronically determine the identity of the device. The Read JEDEC ID instruction is congruous with the JEDEC standard for SPI compatible serial flash memories that was adopted in 2003. The instruction is entered by driving the /CS pin low with following the instruction code "9Fh". JEDEC assigned Manufacturer ID byte for FIDELIX (F8h) and two Device ID bytes, Memory Type (ID-15-ID8) and Capacity (ID7-ID0) are then shifted out on the falling edge of CLK with most significant bit (MSB) first shown in figure 28. For memory type and capacity values refer to Manufacturer and Device Identification table. The JEDEC ID can be read continuously. The instruction is terminated by driving /CS high.

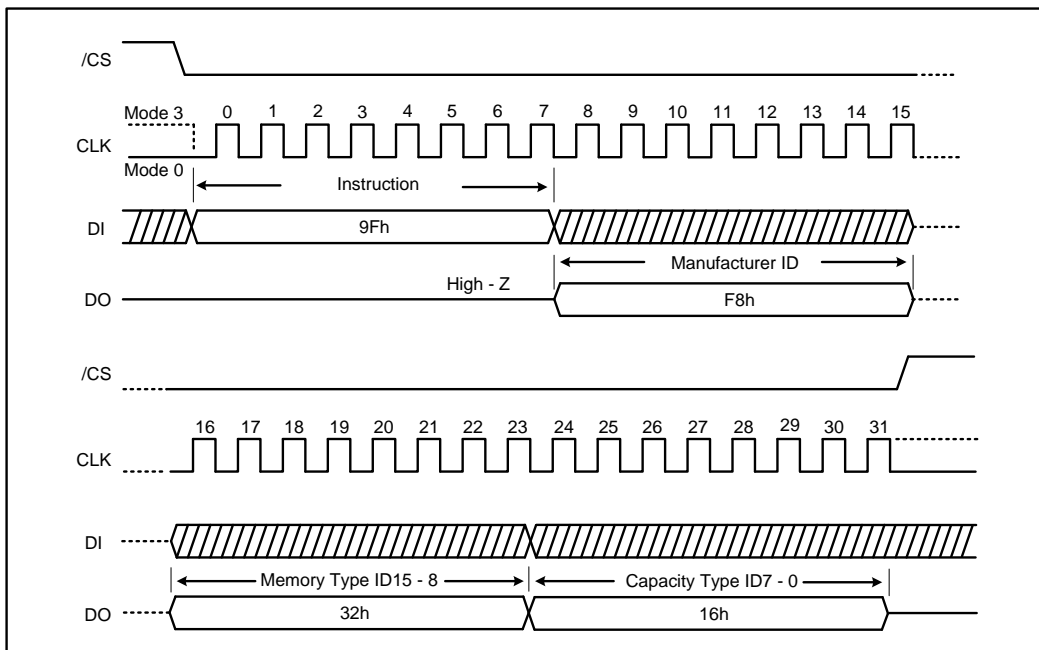

Figure 28. Read JEDEC ID

10.28 Read Serial Flash Discovery Parameter (5Ah)

The Read Serial Flash Discovery Parameter (SFDP) instruction allows reading the Serial Flash Discovery Parameter area (SFDP). This SFDP area is composed of 2048 read-only bytes containing operating characteristics and vendor specific information. The SFDP area is factory programmed. If the SFDP area is blank, the device is shipped with all the SFDP bytes at FFh. If only a portion of the SFDP area is written to, the portion not used is shipped with bytes in erased state (FFh). The instruction sequence for the read SFDP has the same structure as that of a Fast Read instruction. First, the device is selected by driving Chip Select (/CS) Low. Next, the 8-bit instruction code (5Ah) and the 24-bit address are shifted in, with following 8 dummy clock cycles. The bytes of SFDP content are shifted out on the Serial Data Output (DO) starting from the specified address. Each bit is shifted out during the falling edge of Serial Clock (CLK). The instruction sequence is shown here. The Read SFDP instruction is terminated by driving Chip Select (/CS) High at any time during data output.

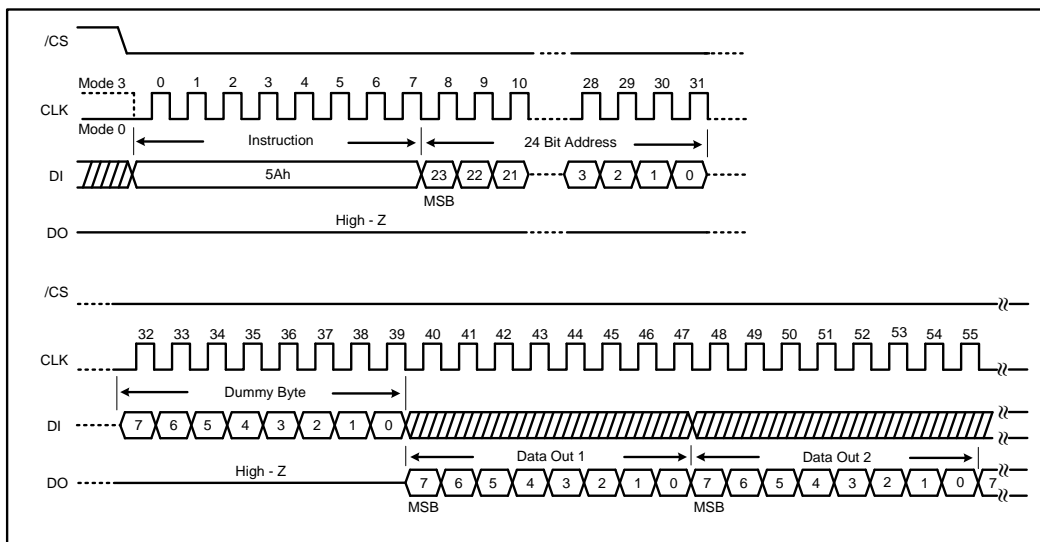

Figure 29. Read SFDP Register Instruction Sequence Diagram

Read Serial Flash Discovery Parameter(SFDP)

BYTE ADDRESS	DATA	DESCRIPTION	COMMENT
00h	53h	SFDP Signature	SFDP Signature =50444653h
01h	46h	SFDP Signature	
02h	44h	SFDP Signature	
03h	50h	SFDP Signature	
04h	01h	SFDP Minor Revisions	SFDP revision 1.1
05h	01h	SFDP Major Revisions	
06h	00h	Number of Parameter Header(NPH)	1 Parameter Header
07h	FFh	Reserved	
08h	F8h	PID(0) ⁽³⁾ : Manufacture JEDEC ID	F8h = Fidelix
09h	00h	PID(0) : Serial Flash Basics Minor Revisions	Serial Flash Basics Revision 1.0
0Ah	01h	PID(0) : Serial Flash Basics Major Revisions	
0Bh	04h	PID(0) : Serial Flash Basics Length	4 Dwords ⁽²⁾
0Ch	80h	PID(0) : Address of Parameter ID(0) Table (A7-A0)	PID(0) Table Address = 000080h
0Dh	00h	PID(0) : Address of Parameter ID(0) Table (A15-A8)	
0Eh	00h	PID(0) : Address of Parameter ID(0) Table (A23-A16)	
0Fh	FFh	Reserved	
10h	F8h	PID(1) : Manufacture JEDEC ID	F8h = Fidelix
11h	00h	PID(1) : Serial Flash Properties Minor Revisions	Serial Flash Basics Revision 1.0
12h	01h	PID(1) : Serial Flash Properties Major Revisions	
13h	00h	PID(1) : Serial Flash Properties Length	00h = Unimplemented
14h	90h	PID(1) : Address of Parameter ID(0) Table (A7-A0)	PID(1) Table Address = 000090h
15h	00h	PID(1) : Address of Parameter ID(0) Table (A15-A8)	
16h	00h	PID(1) : Address of Parameter ID(0) Table (A23-A16)	
17h	FFh	Reserved	
... ⁽¹⁾	FFh	Reserved	
80h	E5h	Bit[7:5] = 111 Reserved	
		Bit[4:3] = 00 Non-volatile Status Register	
		Bit[2] = 1 Page Programmable	
		Bit[1:0] = 01 Support 4KB Erase	

Read Serial Flash Discovery Parameter(SFDP) (cont'd)

BYTE ADDRESS	DATA	DESCRIPTION	COMMENT
81h	20h	4K-Byte Erase Opcode	
82h	F1h	Bit[7] = 1 Reserved	
		Bit[6] = 1 Supports Single Input Quad Output	
		Bit[5] = 1 Supports Quad Input Quad Output	
		Bit[4] = 1 Supports Dual Input Dual Output	
		Bit[3] = 0 Dual Transfer Rate not Supported	
		Bit[2:1] = 00 3-Byte/24-Bit Addressing	
		Bit[1] = 1 Supports Single Input Dual Output	
83h	FFh	Reserved	
84h	FFh	Flash Size in Bits	32 Mega Bits = 01FFFFFFh
85h	FFh	Flash Size in Bits	
86h	FFh	Flash Size in Bits	
87h	01h	Flash Size in Bits	
88h	44h	Bit[7:5] = 010 8 Mode Bits are needed Bit[4:0] = 00100 16 Dummy Bits are needed	
89h	EBh	Quad Input Quad Output Fast Read Opcode	
8Ah	08h	Bit[7:5] = 000 No Mode Bits are needed	Fast Read Quad Output Setting
		Bit[4:0] = 01000 8 Dummy Bits are needed	
8Bh	6Bh	Single Input Quad Output Fast Read Opcode	
8Ch	08h	Bit[7:5] = 000 No Mode Bits are needed	Fast Read Dual Output Setting
		Bit[4:0] = 01000 8 Dummy Bits are needed	
8Dh	3Bh	Single Input Dual Output Fast Read Opcode	
8Eh	80h	Bit[7:5] = 100 8 Mode Bits are needed	Fast Read Dual I/O Setting
		Bit[4:0] = 00000 No Dummy Bits are needed	
8Fh	BBh	Dual Input Dual Output Fast Read Opcode	
... ⁽¹⁾	FFh	Reserved	
EFh	FFh	Reserved	
F0h-FFh	xxh	Reserved	

Notes:

1. Data stored in Byte Address 18h to 7Fh & 90h to FFh are Reserved, the value is FFh.
2. 1 Dword = 4 Bytes.
3. PID(x) = Parameter Identification Table(x)

10.29 Mode Bit Reset (FFh)

To lessen the effect of instruction overhead, Mode Bit Reset (FFh) can be applied to. In Fast Read Dual/Quad I/O operations, the BBh / EBh instruction is not required if the Mode Bits (M7-0) are set "Ax" hex. (See 10.13 Fast Read Dual I/O and 10.14 Fast Read Quad I/O for detail descriptions).

If the system controller is reset during operation, the flash device will return to the standard SPI operation. Upon Reset of main chip, SPI instruction like Read ID (9Fh) or Fast Read (0Bh) would be sent from the system. FM25Q32 does not have a hardware reset pin like most of other SPI memory. For this reason, FM25Q32 will be put in the unrecognized status for any standard SPI instruction if Mode bits are set to "Ax" hex upon reset. To address this issue, it is recommended to set a Mode bit Reset instruction "FFh" for the first instruction once a system reset. This instruction can ensure the device to allow Standard SPI instruction to be accepted. (Please refer to figure 30).

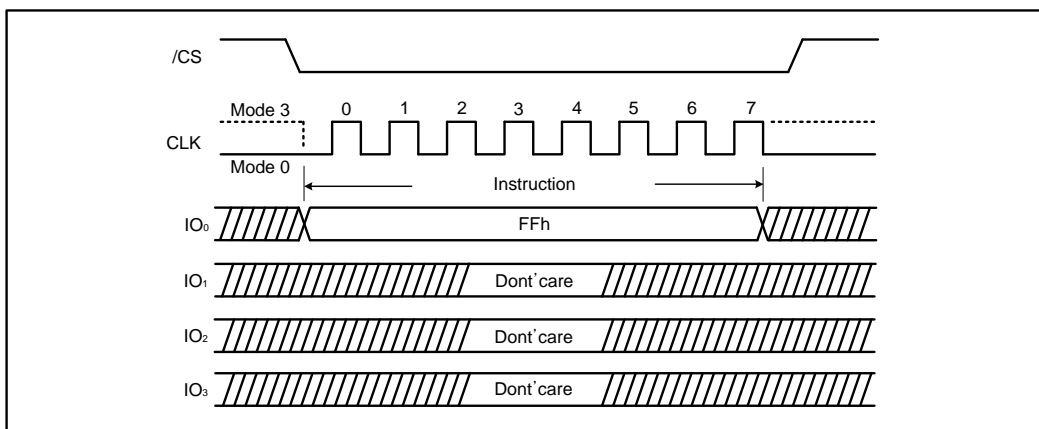

Figure 30. Mode Bits Reset for Fast Read Dual/Quad I/O

10.30 Enter Secured OTP (B1h)

The Enter Secured OTP instruction is for entering the additional 4K-bit secured OTP mode. The additional 4K-bit secured OTP is independent from main array, which may be used to store unique serial number for system identifier. After entering the Secured OTP mode, and then follow standard read or program, procedure to read out the data or update data. The Secured OTP data cannot be updated again once it is lock-down

Please note that WRSR/WRSCUR commands are not acceptable during the access of secure OTP region, once security OTP is lock down, only commands related with read are valid. (Please refer to figure 31).

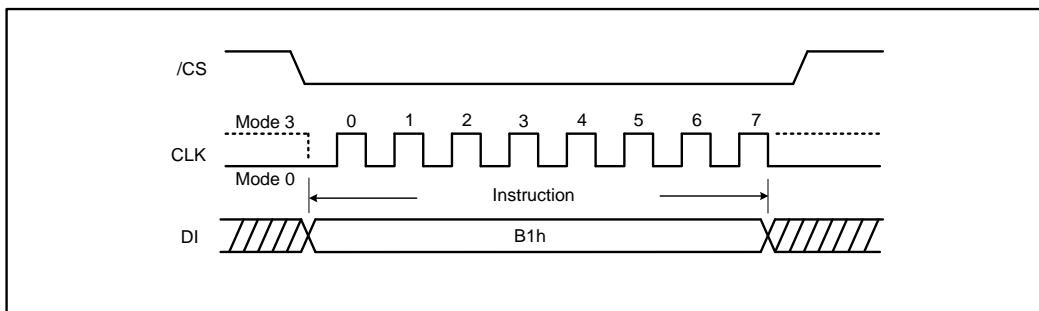

Figure 31. Enter Secured OTP instruction sequence

10.31 Exit Secured OTP (C1h)

The Exit Secured OTP instruction is for exiting the additional 4K-bit secured OTP mode. (Please refer to figure 32).

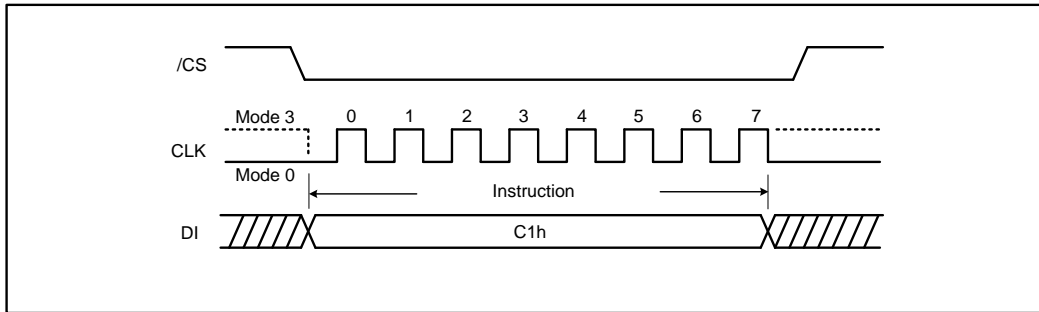

Figure 32. Exit Secured OTP instruction sequence

10.32 Read Security Register (2Bh)

The Read Security Register instruction is to read the value of Security Register bits. The Read Security Register can be read at any time (even in program/erase/write status register condition) and continuously.

The definition of the Security Register bits is as below:

Secured OTP Indicator bit. The Secured OTP indicator bit shows the chip is locked by factory before ex-factory or not. When it is “0”, it indicates non-factory lock, “1” indicates factory-lock.

Lock-down Secured OTP (LDSO) bit. By writing WRSCUR instruction, the LDSO bit may be set to “1” for customer lock-down purpose. However, once the bit is set to “1” (Lock-down), the LDSO bit and the 4K-bit Secured OTP area cannot be updated any more. While it is in 4K-bit Secured OTP mode, array access is not allowed to write.

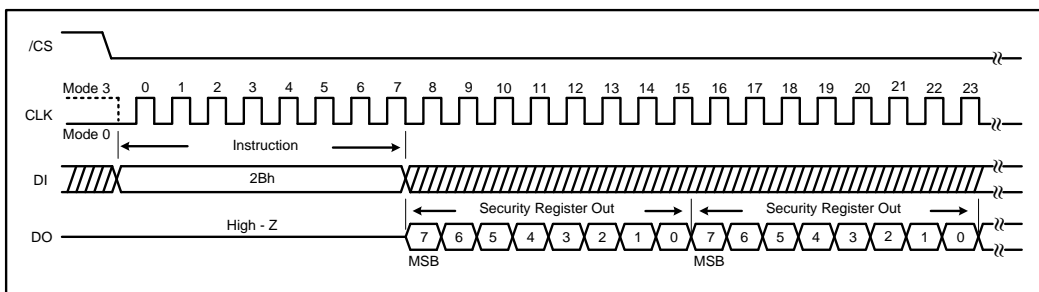

Figure 33. Read Security Register instruction sequence

Security Register Definition

Bit7	Bit6	Bit5	Bit4	Bit3	Bit2	Bit1	Bit0
x	x	x	x	x	x	LDSO (indicate if lock- down)	Secured OTP indicator bit
reserved	reserved	reserved	reserved	reserved	reserved	0 = not lock-down 1 = lock- down(can not program/e rase OTP)	0 = non factory lock 1 = factory lock
Volatile bit	Volatile bit	Volatile bit	Volatile bit	Volatile bit	Volatile bit	Non- Volatile bit	Non- Volatile bit

10.33 Write Security Register (2Fh)

The Write Security Register instruction is to change the value of Security Register bits. Even it is writing command, it does not require WREN instruction prior to writing WRSCUR instruction. The WRSCUR instruction may change the value of bit1 (LDSO bit) for customer to lock-down the 4K-bit Secured OTP area. If the Idso bit is set to "1", the Secured OTP area can not be updated any more.

To accept the instruction, /CS must keep high at the boundary.

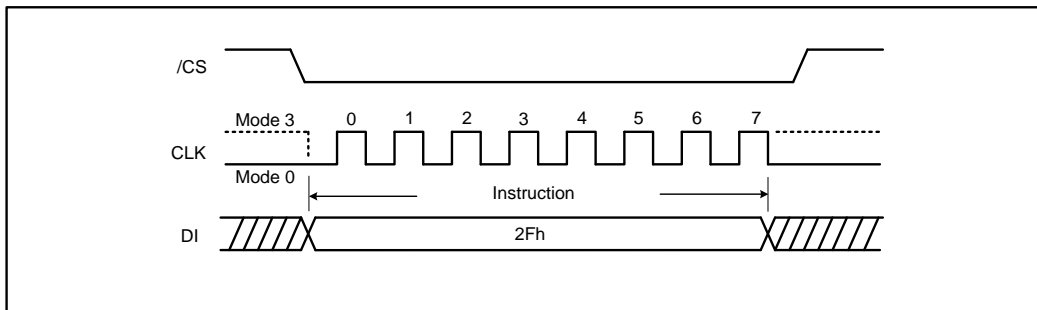

Figure 34. Write Security Register instruction sequence

10.34 Set Burst with Wrap (77h)

The Set Burst with Wrap (77h) instruction is to define Burst length 8/16/32/64-byte section within a 256-byte page in “Fast Read Quad I/O”.

Similar to a Quad I/O instruction, the Set Burst with Wrap instruction is initiated by driving the /CS pin low and then sending the instruction code “77h” with following 24 dummy bits and 8 “Wrap Bits”, W7-0. The instruction sequence is shown in Set Burst with Wrap Instruction Sequence.

Wrap bit W7 and the lower nibble W3-0 are not used.

W6, W5	W4 = 0		W4 = 1(Default)	
	Wrap Around	Wrap Length	Wrap Around	Wrap Length
0 0	Yes	8-byte	No	N/A
0 1	Yes	16-byte	No	N/A
1 0	Yes	32-byte	No	N/A
1 1	Yes	64-byte	No	N/A

Once W6-4 is set by a Set Burst with Wrap instruction, all the following “Fast Read Quad I/O” and instructions will use the W6-4 setting to access the 8/16/32/64-byte section within any page. To exit the “Wrap Around” function and return to normal read operation, it is require to issue another Set Burst with Wrap instruction with setting W4 = 1. The default value of W4 upon power on is W4=1.

If a system reset under Wrap Around mode with W4=0, issuing a Set Burst with Wrap instruction with W4=1 is recommended prior to any normal Read instructions as FM25Q32 does not have a hardware Reset Pin.

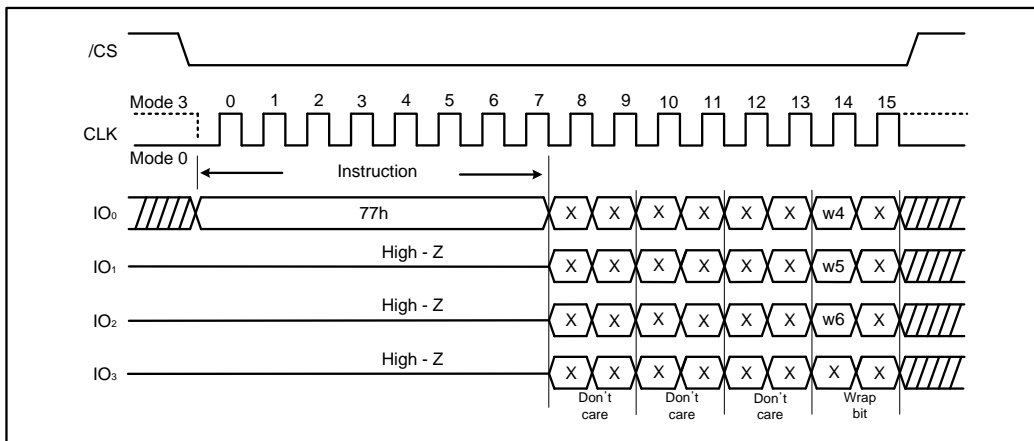

Figure 35. Set Burst with Wrap Instruction Sequence

11. 4K-bit Secured OTP

It's for unique identifier to provide 4K-bit one-time-program area for setting device unique serial number which may be set by factory or system customer. Please refer to table of "4K-bit secured OTP definition".

- Security register bit 0 indicates whether the chip is locked by factory or not.
- To program the 4K-bit secured OTP by entering 4K-bit secured OTP mode (with ENSO command) and going through normal program procedure, and then exiting 4K-bit secured OTP mode by writing EXSO command
- Customer may lock-down bit1 as "1". Please refer to "table of security register definition" for security register bit definition and table of "4K-bit secured OTP definition" for address range definition.
- Note. Once lock-down whatever by factory or customer, it cannot be changed any more. While in 4K-bit secured OTP mode, array access is not allowed to write.

4K-bit secured OTP definition

Address range	Size	Standard Factory Lock	Customer Lock
000000 ~ 00000F	128-bit	ESN (Electrical Serial Number)	Determined by customer
000010 ~ 0001FF	3968-bit	N/A	

12. ELECTRICAL CHARACTERISTICS

12.1 Absolute Maximum Ratings ⁽¹⁾

PARAMETERS	SYMBOL	CONDITIONS	RANGE	UNIT
Supply Voltage	VCC		-0.6 to +4.0	V
Voltage Applied to Any Pin	VIO	Relative to Ground	-0.6 to VCC +0.4	V
Transient Voltage on any Pin	VIOT	<20nS Transient Relative to Ground	-2.0V to VCC +2.0V	V
Storage Temperature	TSTG		-65 to +150	°C
Lead Temperature	TLEAD		See Note ⁽³⁾	°C
Electrostatic Discharge Voltage	VESD	Human Body Model ⁽⁴⁾	-2000 to +2000	V

Notes:

1. Specification for FM25Q32 is preliminary. See preliminary designation at the end of this document.
2. This device has been designed and tested for the specified operation ranges. Proper operation outside of these levels is not guaranteed. Exposure to absolute maximum ratings may affect device reliability. Exposure beyond absolute maximum ratings may cause permanent damage.
3. Compliant with JEDEC Standard J-STD-20C for small body Sn-Pb or Pb-free (Green) assembly and the European directive on restrictions on hazardous substances (RoHS) 2002/95/EU.
4. JEDEC Std JESD22-A114A (C1=100pF, R1=1500 ohms, R2=500 ohms).

12.2 Operating Ranges

PARAMETER	SYMBOL	CONDITIONS	MIN	MAX	UNIT
Erase/Program Cycles	VCC	FR1 = 85MHz (Single/Dual/Quad SPI) FR2 = 104MHz (Single/Dual/Quad SPI) fR = 50MHz (Read Data 03h)	2.7 3.0 2.7	3.6	V
Temperature, Operating	Tj	Industrial	-40	+85	°C

12.3 Endurance and Data Retention

PARAMETER	CONDITIONS	MIN	MAX	UNIT
Erase/Program Cycles	4KB sector, 32/64KB block or full chip.	100,000		Cycles
Data Retention	Full Temperature Range		20	years

12.4 Power-up Timing and Write Inhibit Threshold

PARAMETER	SYMBOL	SPEC		UNIT
		MIN	MAX	
VCC(min) to /CS Low	$t_{VSL}^{(1)}$	10		μs
Time Delay Before Write Instruction	$t_{PUW}^{(1)}$	1	10	ms
Write Inhibit Threshold Voltage	VWI ⁽¹⁾	1	2	V

Note:

1. These parameters are characterized only.

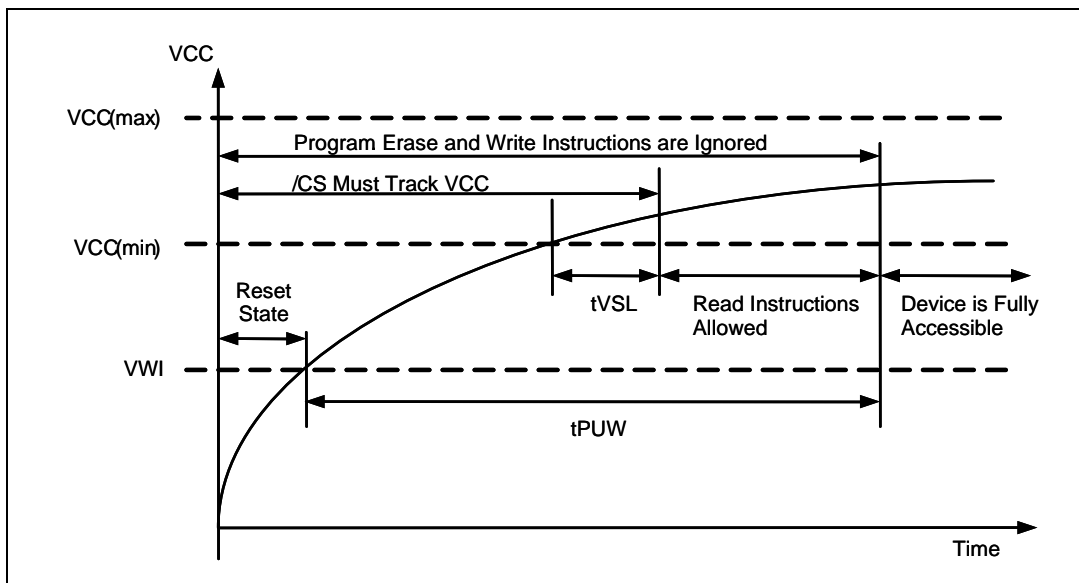

Figure 36. Power-up Timing and Voltage Levels

12.5 DC Electrical Characteristics

PARAMETER	SYMBOL	CONDITION	SPEC			UNIT
			MIN	TYP	MAX	
Input Capacitance	CIN ⁽¹⁾	VIN=0V ⁽²⁾			6	pF
Output Capacitance	COU ⁽¹⁾	VOU=0V ⁽²⁾			8	pF
Input Leakage	ILI				±2	μA
I/O Leakage	ILO				±2	μA
Standby Current	ICC1	/CS=VCC, VIN=GND or VCC		10	50	μA
Deep Power-down Current	ICC2	/CS=VCC, VIN=GND or VCC		3	10	μA
Current Read Data/ Dual/Quad 1MHz ⁽²⁾	ICC3	C=0.1 VCC / 0.9VCC IO=Open		4/5/6	6/7.5/9	mA
Current Read Data/ Dual/Quad 33MHz ⁽²⁾	ICC3	C=0.1 VCC / 0.9VCC IO=Open		6/7/8	9/10.5/12	mA
Current Read Data/ Dual/Quad 50MHz ⁽²⁾	ICC3	C=0.1 VCC / 0.9VCC IO=Open		7/8/9	10/12/13.5	mA
Current Read Data/ Dual/Quad 85MHz ⁽²⁾	ICC3	C=0.1 VCC / 0.9VCC IO=Open		10/11/12	15/16.5/18	mA
Current Write Status Register	ICC4	/CS=VCC		10	18	mA
Current page Program	ICC5	/CS=VCC		20	25	mA
Current Sector/Block Erase	ICC6	/CS=VCC		20	25	mA
Current Chip Erase	ICC7	/CS=VCC		20	25	mA
Input Low Voltages	VIL		-0.5		VCC x0.2	V
Input High Voltages	VIH		VCC x0.8		VCC +0.4	V
Output Low Voltages	VOL	IOL=1.6mA			0.4	V
Output High Voltages	VOH	IOH=-100μA	VCC -0.2			V

Notes:

1. Tested on sample basis and specified through design and characterization data, TA = 25°C, VCC = 3V.
2. Checked Board Pattern.

12.6 AC Measurement Conditions

PARAMETER	SYMBOL	SPEC		UNIT
		MIN	MAX	
Load Capacitance	C_L		30	pF
Input Rise and Fall Times	T_R, T_F		5	ns
Input Pulse Voltages	V_{IN}	0.2 VCC to 0.8 VCC		V
Input Timing Reference Voltages	IN	0.3 VCC to 0.7 VCC		V
Output Timing Reference Voltages	OUT	0.5 VCC to 0.5 VCC		V

Note:

1. Output Hi-Z is defined as the point where data out is no longer driven.

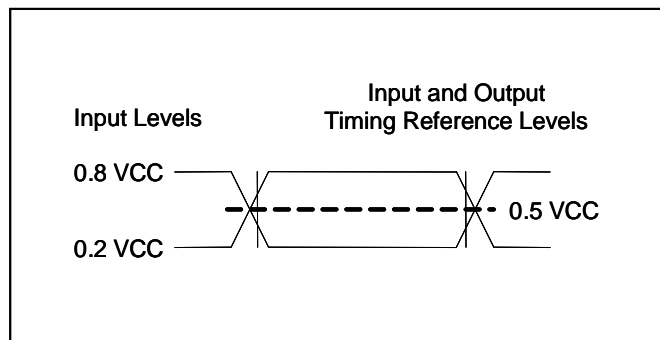

Figure 37. AC Measurement I/O Waveform

12.7 AC Electrical Characteristics

DESCRIPTION	SYMBOL	ALT	SPEC			UNIT
			MIN	TYP	MAX	
Clock frequency For all instructions, except Read Data (03h) 2.7V-3.6V VCC & Industrial Temperature	FR1	f_c	D.C.		85	MHz
Clock frequency For all instructions, except Read Data (03h) 3.0V-3.6V VCC & Commercial Temperature	FR2	f_c	D.C.		104	MHz
Clock freq. Read Data instruction (03h)	f_R		D.C.		50	MHz
Clock High, Low Time except Read Data (03h)	tCLH, tCLL ⁽¹⁾		4			ns
Clock High, Low Time for Read Data (03h) instructions	tCRLH, tCRL ⁽¹⁾		6			ns
Clock Rise Time peak to peak	tCLCH ⁽²⁾		0.1			V/ns
Clock Fall Time peak to peak	tCHCL ⁽²⁾		0.1			V/ns
/CS Active Setup Time relative to CLK	tSLCH	tCSS	7			ns
/CS Not Active Hold Time relative to CLK	tCHSL		5			ns
Data In Setup Time	tDVCH	tDSU	4			ns
Data In Hold Time	tCHDX	tDH	4			ns
/CS Active Hold Time relative to CLK	tCHSH		7			ns
/CS Not Active Setup Time relative to CLK	tSHCH		7			ns
/CS Deselect Time (for Read instructions/ Write, Erase and Program instructions)	tSHSL	tCSH	10/40			ns
Output Disable Time	tSHQZ ⁽²⁾	tDIS			7	ns
Clock Low to Output Valid 2.7V-3.6V / 3.0V-3.6V	tCLQV	tV			7/6	ns
Output Hold Time	tCLQX	tHO	0			ns
/Hold Active Setup Time relative to CLK	tHLCH		7			ns

12.8 AC Electrical Characteristics (cont'd)

DESCRIPTION	SYMBOL	ALT	SPEC			UNIT
			MIN	TYP	MAX	
/HOLD Active Hold Time relative to CLK	tCHHH		5			ns
/HOLD Not Active Setup Time relative to CLK	tHHCH		7			ns
/HOLD Not Active Hold Time relative to CLK	tCHHL		5			ns
/HOLD to Output Low-Z	tHHQX ⁽²⁾	t _{LZ}			7	ns
/HOLD to Output High-Z	tHLQZ ⁽²⁾	t _{HZ}			12	ns
Write Protect Setup Time Before /CS Low	tWHSL ⁽³⁾		20			ns
Write Protect Setup Time After /CS High	tSHWL ⁽³⁾		100			ns
/CS High to Deep Power-down Mode	tDP ⁽²⁾				3	μs
/CS High to Standby Mode without Electronic Signature Read	tRES1 ⁽²⁾				3	μs
/CS High to Standby Mode with Electronic Signature Read	tRES2 ⁽²⁾				1.8	μs
/CS High to next Instruction after Suspend	tSUS ⁽²⁾				20	μs
Write Status Register Time	t _w			10	15	ms
Byte Program Time	t _{BP}			10	150	μs
Page Program Time	t _{PP}			1.5	5	ms
Sector Erase Time(4KB)	t _{SE}			40	300	ms
Block Erase Time(32KB)	t _{BE1}			200	1000	ms
Block Erase Time(64KB)	t _{BE2}			300	1500	ms
Chip Erase Time	t _{CE}			16	50	s

Notes:

1. Clock high + Clock low must be less than or equal to 1/fc.
2. Value guaranteed by design and/or characterization, not 100% tested in production.
3. Only applicable as a constraint for a Write Status Register instruction when Sector Protect Bit is set to 1.
4. Commercial temperature only applies to Fast Read (F_{R1} & F_{R2}). Industrial temperature applies to all other parameters.

12.9 Serial Output Timing

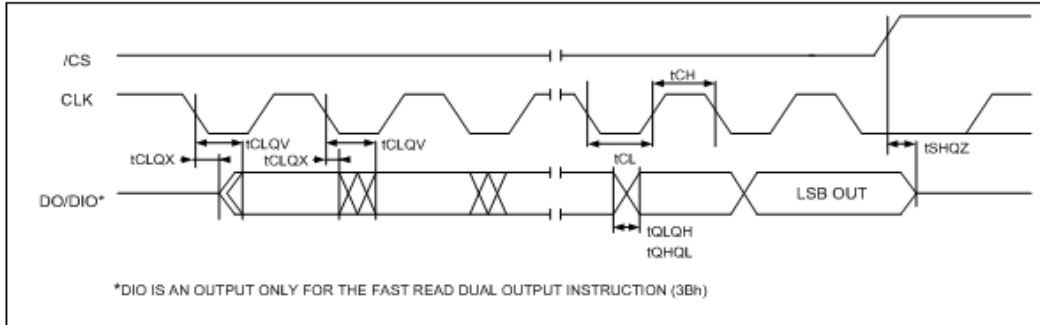

12.10 Input Timing

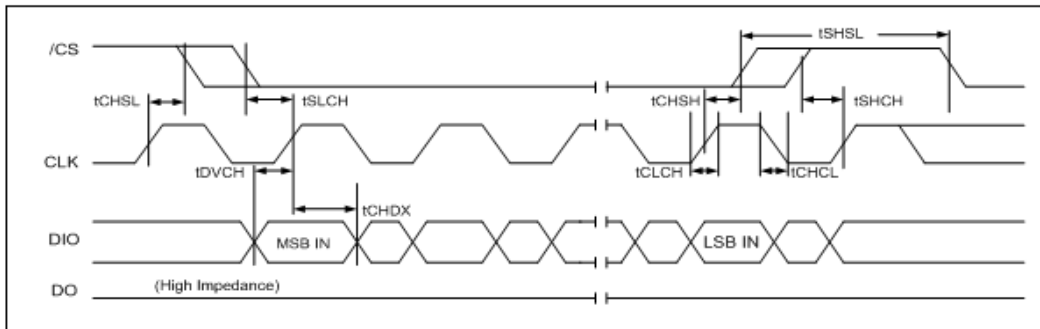

12.11 Hold Timing

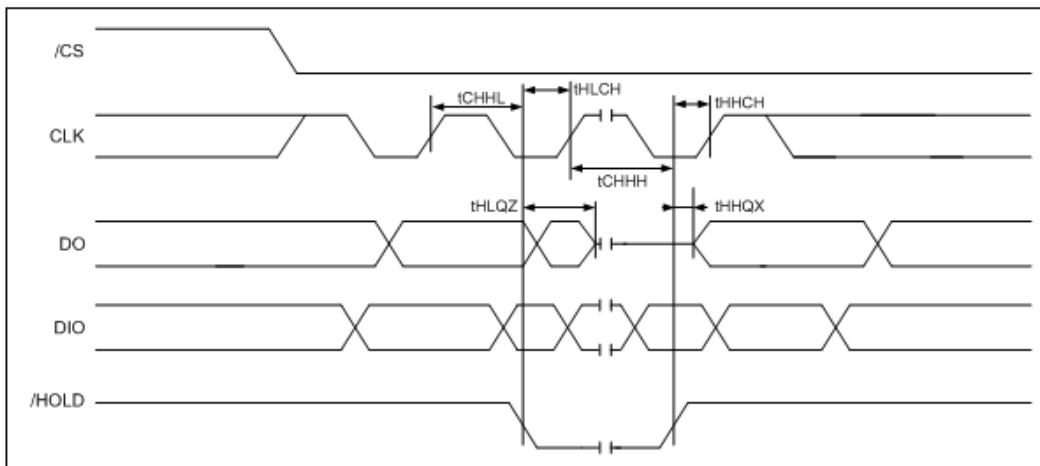

13. PACKAGE SPECIFICATION

13.1 8-Pin SOIC 208-mil

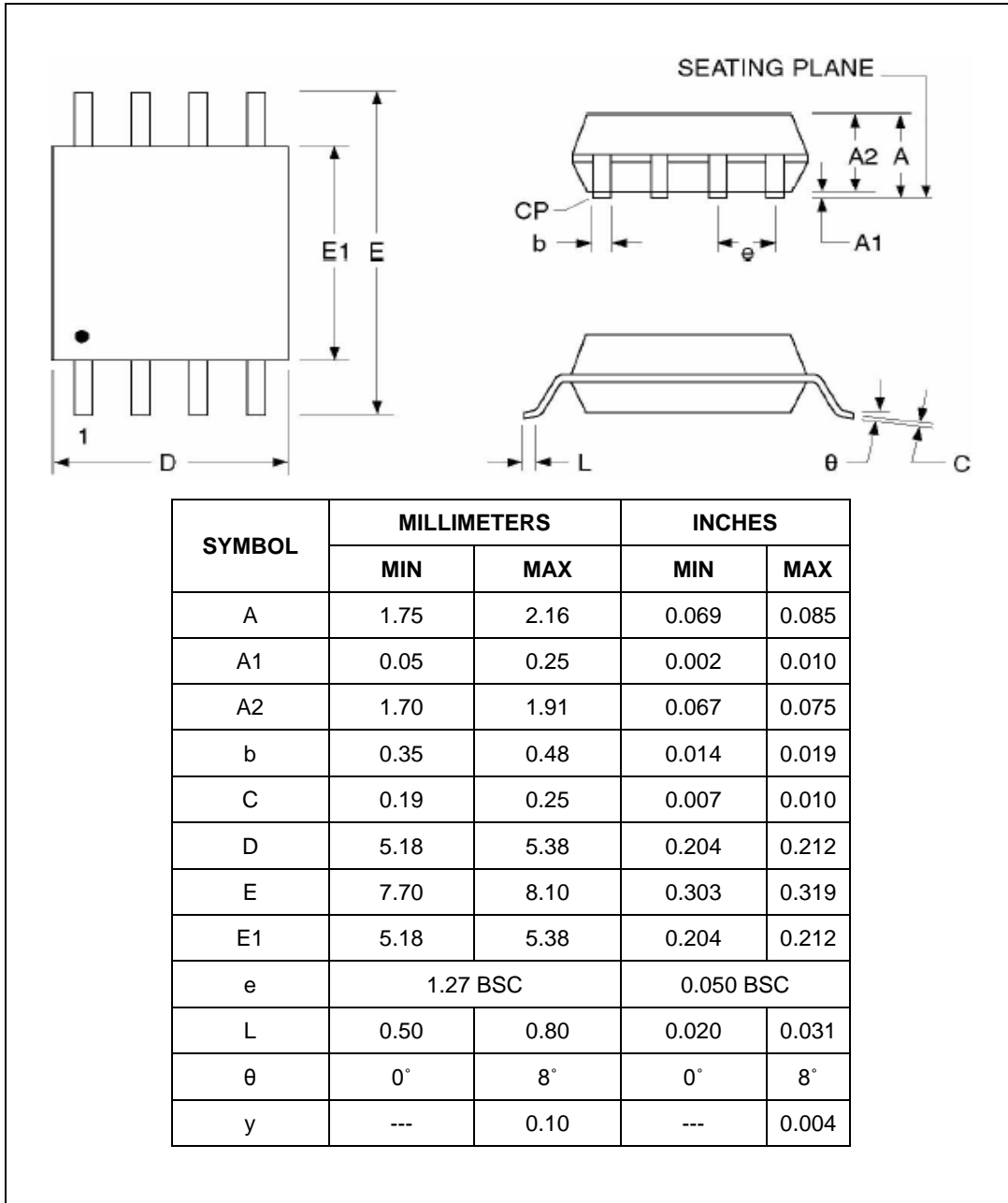

Notes:

1. Controlling dimensions: inches, unless otherwise specified.
2. BSC = Basic lead spacing between centers.
3. Dimensions D and E1 do not include mold flash protrusions and should be measured from the bottom of the package.
4. Formed leads shall be planar with respect to one another within. 0004 inches at the seating plane.

13.2 8-Pin VSOP 208-mil

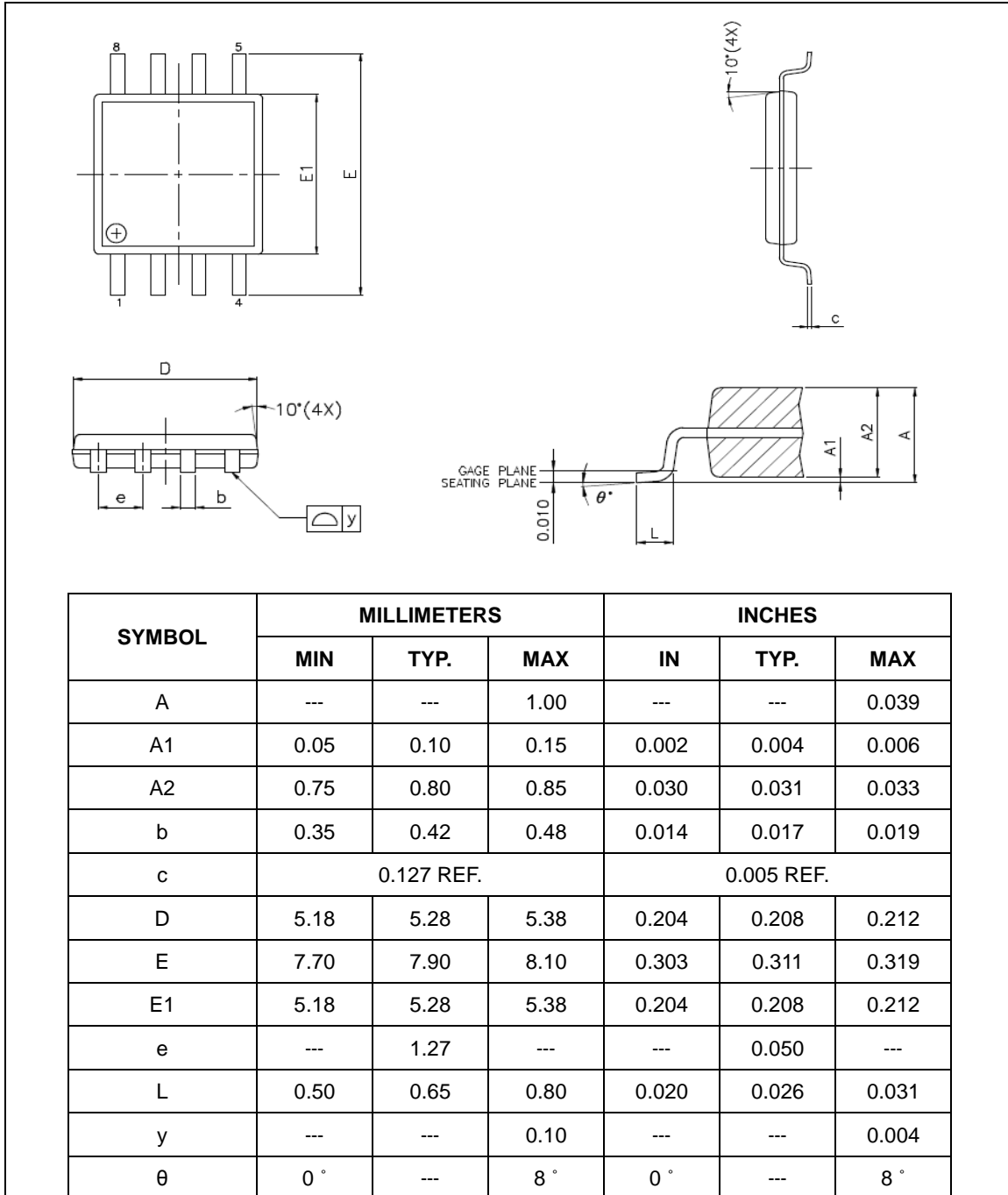
Notes:

1. JEDEC outline : N/A.
2. Dimension "D", "D1" does not include mold flash, mold flash shall not exceed 0.006 [0.15mm] per end. Dimension "E", "E1" does not include inter lead flash. Inter lead flash shall not exceed 0.010 [0.25mm] per side.
3. Dimension "b" does not include dambar protrusion. Allowable dambar protrusion shall be 0.003 [0.08mm].

13.3 8-Pin PDIP 300-mil

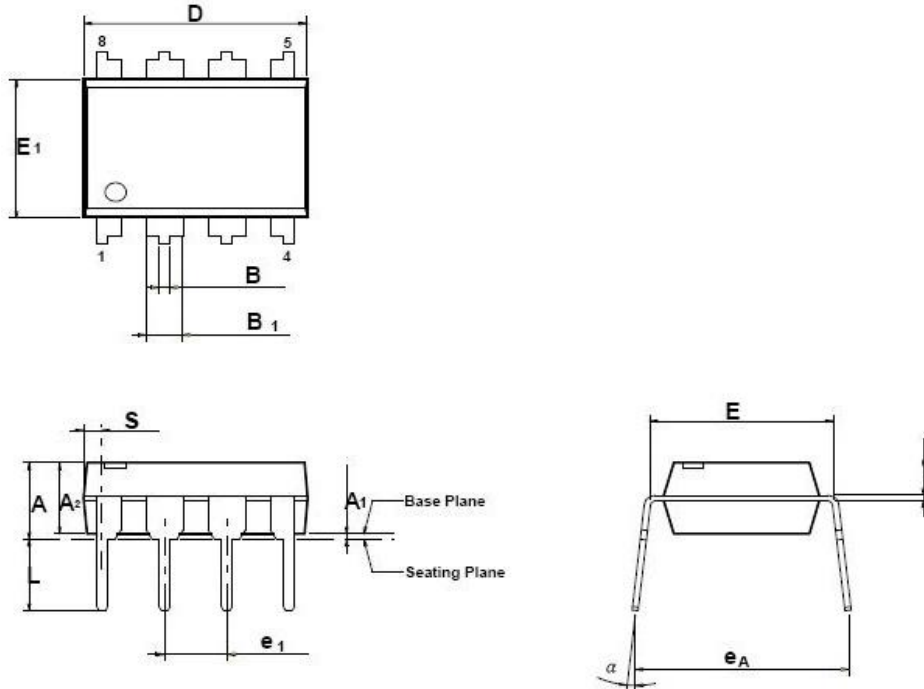

SYMBOL	Dimension in inch			Dimension in min		
	MIN	Nom	MAX	MIN	Nom	MAX
A	---	---	0.210	---	---	5.334
A ₁	0.015	---	---	0.381	---	---
A ₂	0.125	0.130	0.135	3.18	3.30	3.43
B	0.016	0.018	0.022	0.41	0.46	0.56
B ₁	0.058	0.060	0.064	1.47	1.52	1.63
c	0.008	0.010	0.014	0.20	0.25	0.36
D	0.360	0.365	0.370	9.14	9.27	9.40
E	0.290	0.300	0.310	7.37	7.62	7.87
E ₁	0.245	0.250	0.255	6.22	6.35	6.48
e ₁	0.090	0.100	0.110	2.29	2.54	2.79
L	0.120	0.130	0.140	3.05	3.30	3.56
α	0	---	15	0	---	15
e A	0.335	0.355	0.375	8.51	9.02	9.53
S	---	--	0.045	---	---	1.14

13.4 8-contact 6x5 WSON

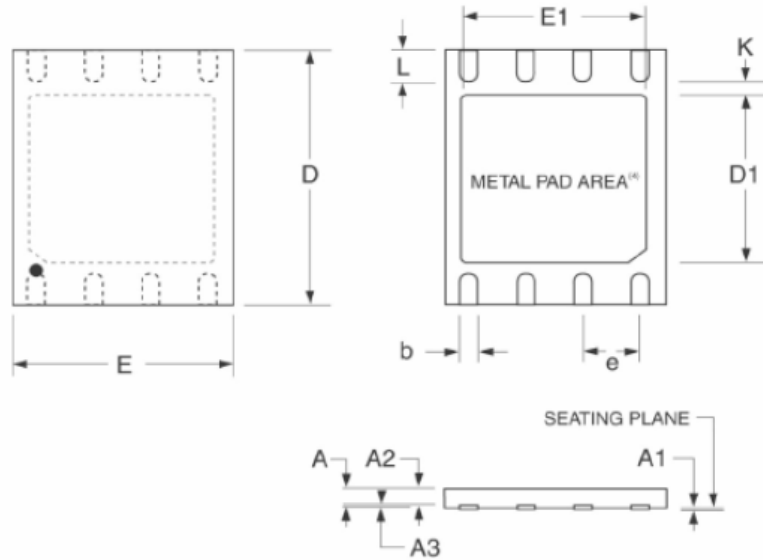

SYMBOL	MILLIMETERS			INCHES		
	MIN	TYP.	MAX	IN	TYP.	MAX
A	0.70	0.75	0.80	0.0276	0.0295	0.0315
A1	0.00	0.02	0.05	0.0000	0.0008	0.0019
A2		0.55			0.0126	
A3	0.19	0.20	0.25	0.0075	0.0080	0.0098
b	0.36	0.40	0.48	0.0138	0.0157	0.0190
D ⁽³⁾	5.90	6.00	6.10	0.2320	0.2360	0.2400
D1	3.30	3.40	3.50	0.1299	0.1338	0.1377
E	4.90	5.00	5.10	0.1930	0.1970	0.2010
E1 ⁽³⁾	4.20	4.30	4.40	0.1653	0.1692	0.1732
e ⁽²⁾	1.27 BSC			0.0500 BSC		
K	0.20			0.0080		
L	0.50	0.60	0.75	0.0197	0.0236	0.0295

13.5 8-contact 6x5 WSON Cont'd

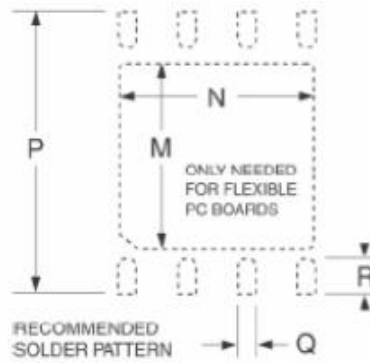

SYMBOL	MILLIMETERS			INCHES		
	MIN	TYP.	MAX	MIN	TYP.	MAX
SOLDER PATTERN						
M		3.40			0.1338	
N		4.30			0.1692	
P		6.00			0.2360	
Q		0.50			0.0196	
R		0.75			0.0255	

Notes:

1. Advanced Packaging Information; please contact Fidelix Co., Ltd. for the latest minimum and maximum specifications.
2. BSC = Basic lead spacing between centers.
3. Dimensions D and E1 do not include mold flash protrusions and should be measured from the bottom of the package.
4. The metal pad area on the bottom center of the package is connected to the device ground (GND pin). Avoid placement of exposed PCB bias under the pad.

13.6 16-Pin SOIC 300-mil

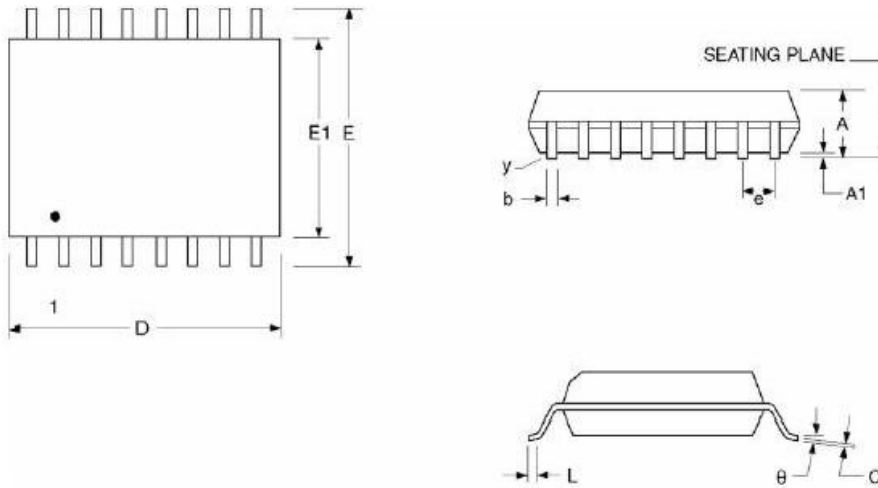

SYMBOL	MILLIMETERS		INCHES	
	MIN	MAX	MIN	MAX
A	2.36	2.64	0.093	0.104
A1	0.10	0.30	0.005	0.012
b	0.33	0.51	0.013	0.020
C	0.18	0.28	0.007	0.000
D ⁽³⁾	10.08	10.49	0.397	0.413
E	10.01	10.64	0.394	0.419
E1 ⁽³⁾	7.39	7.59	0.291	0.299
e ⁽²⁾	1.27BSC		0.050	
L	0.39	1.27	0.015	0.050
θ	0°	8°	0°	8°
y	---	0.076	---	0.003

Notes:

1. Controlling dimensions: inches, unless otherwise specified.
2. BSC = Basic lead spacing between centers.
3. Dimensions D and E1 do not include mold flash protrusions and should be measured from the bottom of the package.

14. ORDERING INFORMATION
