

SURFACE MOUNT SCHOTTKY BARRIER RECTIFIER

VOLTAGE RANGE 20 to 200 Volts CURRENT 3.0 Amperes

FEATURES

- * Ideal for surface mounted applications
- * Low leakage current
- * Metallurgically bonded construction
- * P/N suffix V means AEC-Q101 qualified
- * P/N suffix V means Halogen-free

MECHANICAL DATA

- * Epoxy: Device has UL flammability classification 94V-O
- * Mounting position: Any
- * Weight: 0.057 gram

MAXIMUM RATINGS AND ELECTRICAL CHARACTERISTICS

Ratings at 25 °C ambient temperature unless otherwise specified.
Single phase, half wave, 60 Hz, resistive or inductive load.
For capacitive load, derate current by 20%.

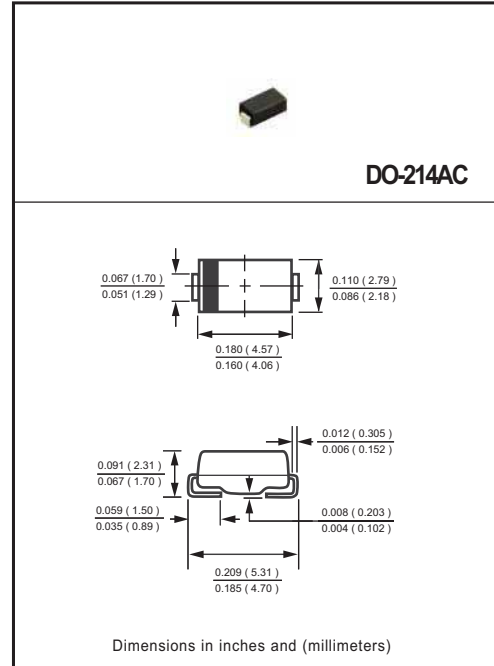

MAXIMUM RATINGS (@ TA=25 °C unless otherwise noted)

RATINGS	SYMBOL	FM320A	FM330A	FM340A	FM350A	FM360A	FM380A	FM3100A	FM3150A	FM3200A	UNITS
Maximum Recurrent Peak Reverse Voltage	V _{RRM}	20	30	40	50	60	80	100	150	200	Volts
Maximum RMS Voltage	V _{RMS}	14	21	28	35	42	56	70	105	140	Volts
Maximum DC Blocking Voltage	V _{DC}	20	30	40	50	60	80	100	150	200	Volts
Maximum Average Forward Rectified Current at Ambient Temperature	I _O	3.0									Amps
Peak Forward Surge Current 8.3 ms single half sine-wave superimposed on rated load (JEDEC method)	I _{FSM}	100									Amps
Typical Current Squared Time	I ² T	41.5									A ² S
Typical Thermal Resistance (Note 1)	R _{θJA}	55									°C/W
	R _{θJL}	17									
Typical Junction Capacitance (Note 2)	C _J	200									pF
Operating Temperature Range	T _J	-55 to + 150									°C
Storage Temperature Range	T _{STG}	-55 to + 150									°C

ELECTRICAL CHARACTERISTICS (@TA=25 °C unless otherwise noted)

CHARACTERISTICS	SYMBOL	FM320A	FM330A	FM340A	FM350A	FM360A	FM380A	FM3100A	FM3150A	FM3200A	UNITS
Maximum Instantaneous Forward Voltage at 3.0A DC	V _F	.55			.75			.79			Volts
Maximum Average Reverse Current at Rated DC Blocking Voltage	I _R	@T _A = 25°C			60			5.0			uA
		@T _A = 150°C			4.0			0.4			mA

NOTES : 1. Thermal Resistance : Mounted on PCB.
2. Measured at 1 MHz and applied reverse voltage of 4.0 volts.

RATING AND CHARACTERISTICS CURVES (FM320A THRU FM3200A)

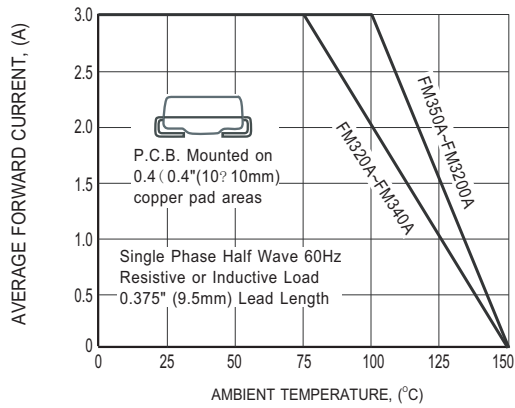

FIG.1 TYPICAL FORWARD CURRENT DERATING CURVE

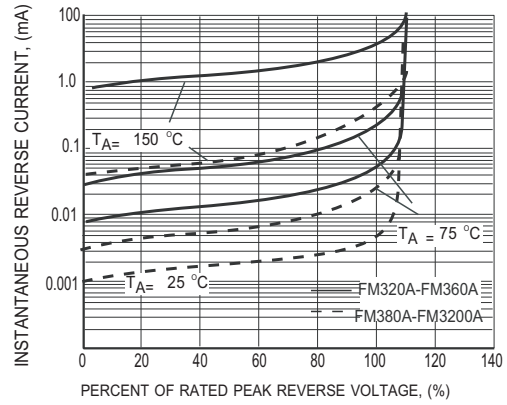

FIG.2 MAXIMUM REVERSE CHARACTERISTICS

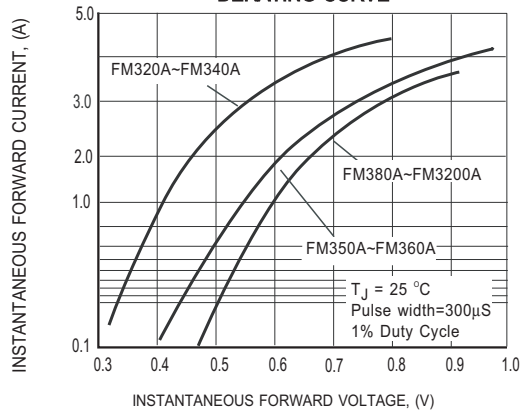

FIG.3 MAXIMUM INSTANTANEOUS FORWARD CHARACTERISTICS

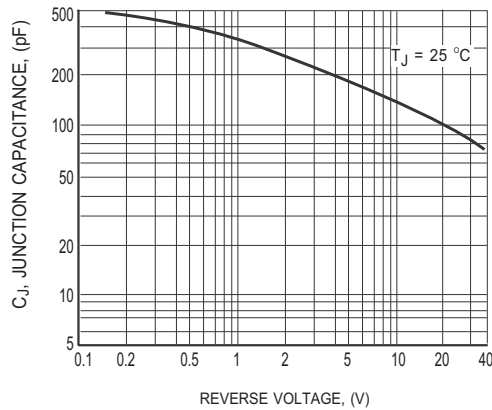

FIG.4 TYPICAL JUNCTION CAPACITANCE

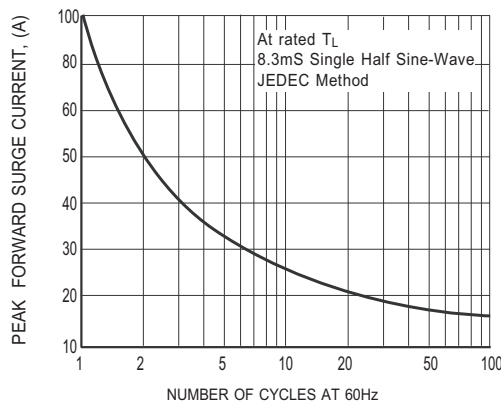
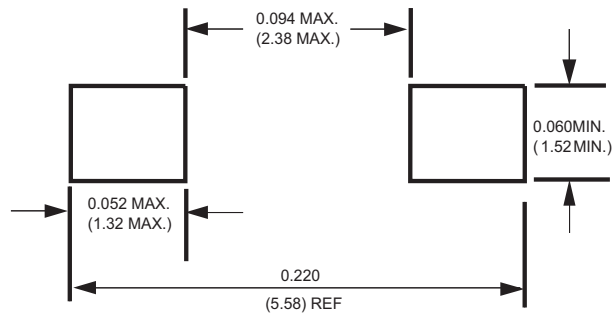

FIG.5 MAXIMUM NON-REPETITIVE FORWARD SURGE CURRENT

Mounting Pad Layout



Dimensions in inches and (millimeters)

Marking Description

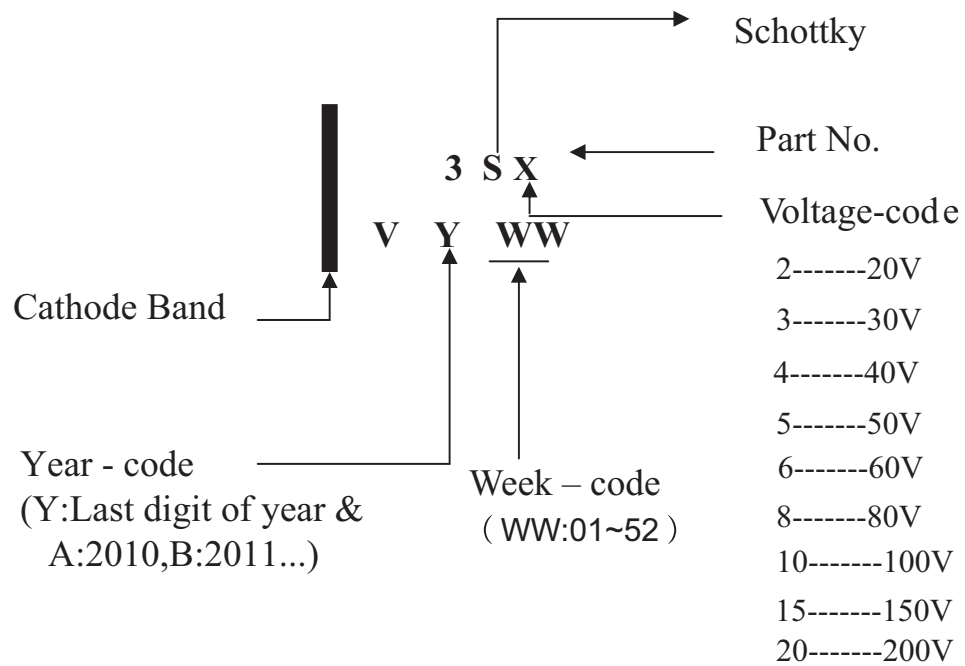

PACKAGING OF DIODE AND BRIDGE RECTIFIERS

REEL PACK

PACKAGE	PACKING CODE	EA PER REEL	EA PER INNER BOX	COMPONENT SPACE (mm)	TAPE SPACE (mm)	REEL DIA (mm)	CARTON SIZE (mm)	EA PER CARTON	GROSS WEIGHT(Kg)
SMA	-T	1,500	6,000	---	---	178	390*205*310	48,000	8.40
SMA	-W	5,000	10,000	---	---	330	360*355*360	80,000	14.20