

150V / 400A

2 - PACK MOSFET MODULE (Half - Bridge)

FEATURES

- Low $R_{DS(on)}$
- High frequency operation
- dv/dt ruggedness
- Fast switching

APPLICATION

- Motor control
- Battery management system
- Electric vehicle, Automotive etc.

INTERNAL CIRCUIT

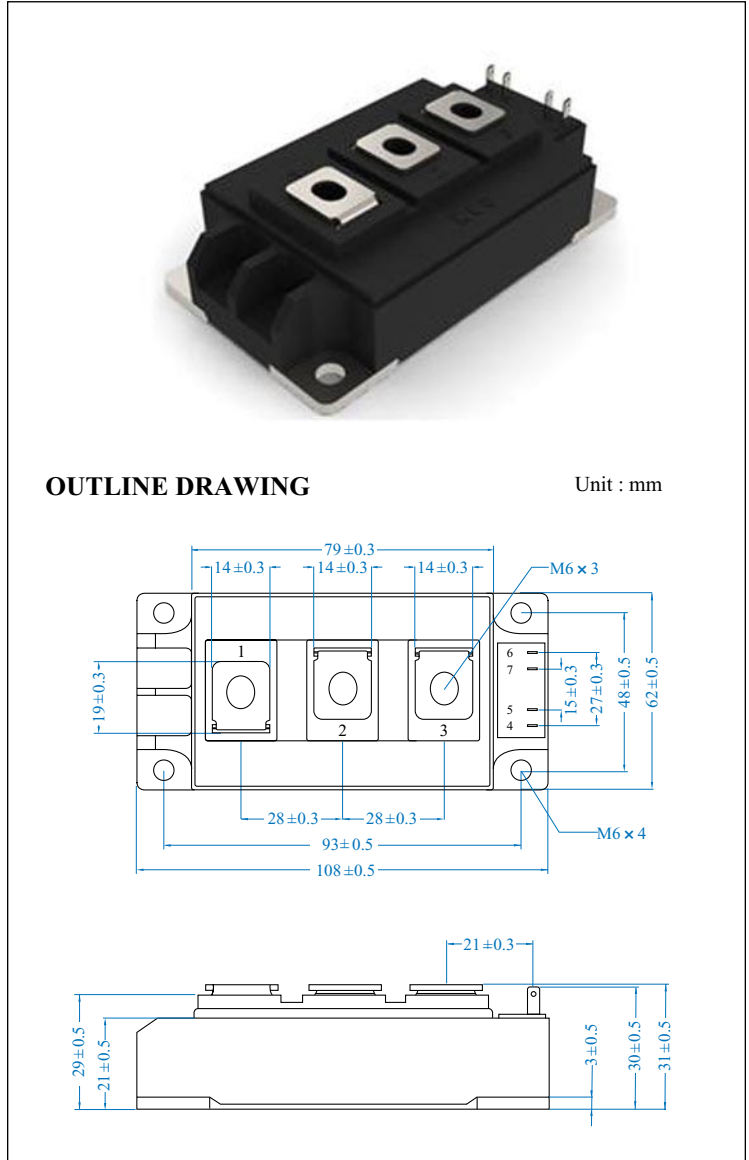
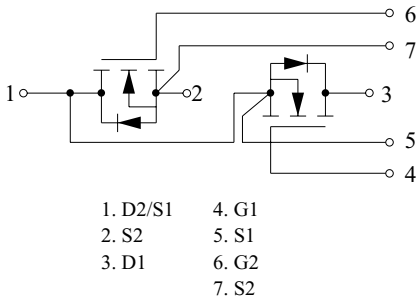

MAXIMUM RATING (@Tc=25 Per Leg, Unless otherwise noted)

CHARACTERISTIC		SYMBOL	RATING	UNIT
Drain-to-Source Breakdown Voltage		V_{DSS}	150	V
Gate to Source Voltage		V_{GSS}	± 30	V
Continuous Drain Current	@T _C =25	I_C	650	A
	@T _C =100		450	
Isolation Voltage Test	AC@1minute	V_{ISO}	2500	V
Junction Temperature		T_J	-40 +150	
Storage Temperature		T_{stg}	-40 +125	
Weight		Weight	360 ± 5	g
Mounting Torque (M6)		M	6	Nm
Terminal Connection Torque (M6)		M	5	Nm

FM400HB1D5C

ELECTRICAL CHARACTERISTICS (@Tc=25 Per Leg, Unless otherwise noted)

CHARACTERISTIC	SYMBOL	TEST CONDITION	MIN.	TYP.	MAX.	UNIT
Static						
Drain-Source Breakdown Voltage	BV_{DSS}	$I_D=250\mu A, V_{GS}=0V$	150	-	-	V
Breakdown Voltage Temperature Coefficient	BV_{DSS}/T_j	$I_D=5mA$, Referenced to 25	-	0.17	-	V/
Gate Threshold Voltage	V_{th}	$V_{DS}=V_{GS}, I_D=250\mu A$	3.0	-	5.0	V
Drain to Source Leakage Current	I_{DSS}	$V_{DS}=150V, V_{GS}=0V$	-	-	80	μA
		$V_{DS}=150V, V_{GS}=0V, T_j=125$	-	-	1000	
pGate to Source Leakage Current	I_{GSS}	$V_{GS}=20V$	-	-	400	nA
		$V_{GS}=-20V$	-	-	-400	nA
Drain to Source ON Resistance	$R_{DS(ON)}$	$V_{GS}=10V, I_D=400A$	-	2.0	3.0	m
Dynamic						
Total Gate Charge	Q_g	$I_D=400A, V_{DS}=75V, V_{GS}=10V$	-	600	-	nC
Gate to Source Charge	Q_{gs}		-	200	-	
Gate to Source Charge	Q_{gd}		-	220	-	
Turn On Delay Time	$t_{d(on)}$	$V_{DS}=75V, I_D=400A, R_G=3.3$	-	110	-	ns
Rise Time	t_r		-	490	-	
Turn Off Delay Time	$t_{d(off)}$		-	180	-	
Fall Time	t_f		-	310	-	
Input Capacitance	C_{iss}	$V_{DS}=50V, V_{GS}=0V, f=1MHz$	-	40	-	nF
Output Capacitance	C_{oss}		-	4	-	
Reverse Transfer Capacitance	C_{rss}		-	0.8	-	
Source-Drain Diode Ratings						
Continuous Source Current	I_S	Internal reverse p-n junction diode.	-	-	450	A
Pulsed Source Current	I_{SP}		-	-	2500	
Diode Forward Voltage	V_{SD}	$I_D=400A, V_{GS}=0V$	-	1.1	1.3	V
Reverse Recovery Time	t_{rr}	$V_R=75V, I_D=400A, di/dt=-100A/us$	-	110	-	ns
Reverse Recovery Charge	Q_{rr}		-	515	-	nC

FM400HB1D5C

Fig 1. Saturation Voltage Characteristics

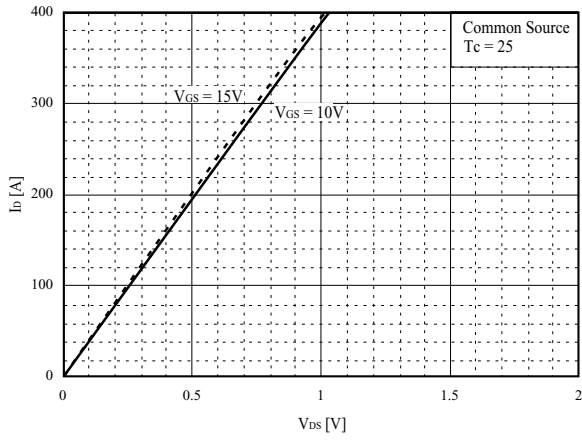

Fig 2. Saturation Voltage Characteristics

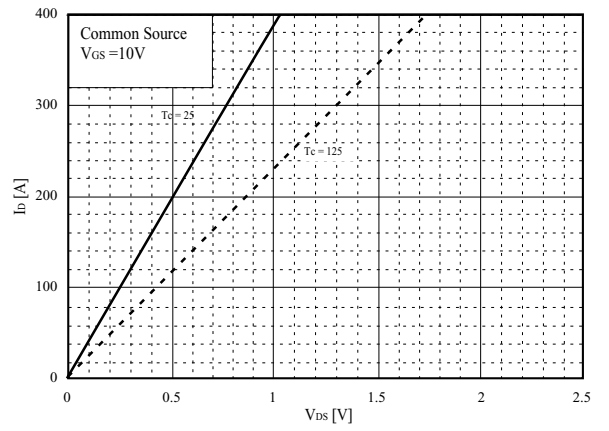

Fig 3. R_{DS(ON)} Characteristics

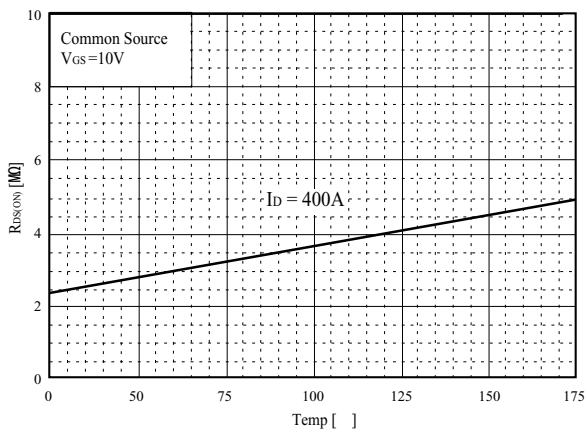

Fig 4. Forward Characteristics of Inverse Diode

