

6.0A Surface Mount General Purpose Rectifiers - 50V-1300V

Features

- Batch process design, excellent power dissipation offers better reverse leakage current and thermal resistance.
- Low profile surface mounted application in order to optimize board space.
- High current capability.
- High surge capability.
- Glass passivated chip junction.
- Lead-free parts meet environmental standards of MIL-STD-19500 /228
- Suffix "-H" indicates Halogen-free parts, ex. FM601C-DG-H.

Mechanical data

- Epoxy: UL94-V0 rated flame retardant
- Case : Molded plastic, TO-252 / DPAK
- Terminals : Solder plated, solderable per MIL-STD-750, Method 2026
- Polarity : Indicated by cathode band
- Mounting Position : Any
- Weight : Approximated 0.34 gram

Maximum ratings (AT T =25°C unless otherwise noted)

PARAMETER	CONDITIONS	Symbol	MIN.	TYP.	MAX.	UNIT
Forward rectified current	See Fig.2	I_o			6.0	A
Forward surge current	8.3ms single half sine-wave superimposed on rate load (JEDEC methode)	I_{FSM}			70	A
Reverse current	$V_R = V_{RRM} T_J = 25^\circ C$	I_R			5.0	μA
	$V_R = V_{RRM} T_J = 125^\circ C$				250	
Thermal resistance	Junction to ambient	$R_{\theta JA}$		47		$^\circ C/W$
Diode junction capacitance	f=1MHz and applied 4vDC reverse voltage	C_J		40		pF
Storage temperature		T_{STG}	-55		+150	$^\circ C$

SYMBOLS	V_{RRM}^{*1} (V)	V_{RMS}^{*2} (V)	V_R^{*3} (V)	V_F^{*4} (V)	Operating temperature $T_J, (^\circ C)$
FM601C-DG	100	70	100	1.10	-55 to +150
FM602C-DG	200	140	200		
FM604C-DG	400	280	400		
FM606C-DG	600	420	600		
FM608C-DG	800	560	800		
FM610C-DG	1000	700	1000		

- *1 Repetitive peak reverse voltage
- *2 RMS voltage
- *3 Continuous reverse voltage
- *4 Maximum forward voltage@ $I_F=3.0A$

Package outline

TO-252AC

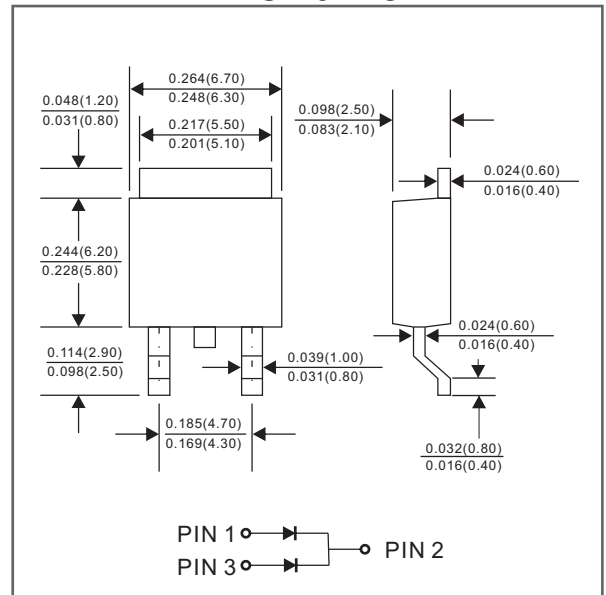

Dimensions in inches and (millimeters)

Rating and characteristic curves

FIG.1-TYPICAL FORWARD CHARACTERISTICS

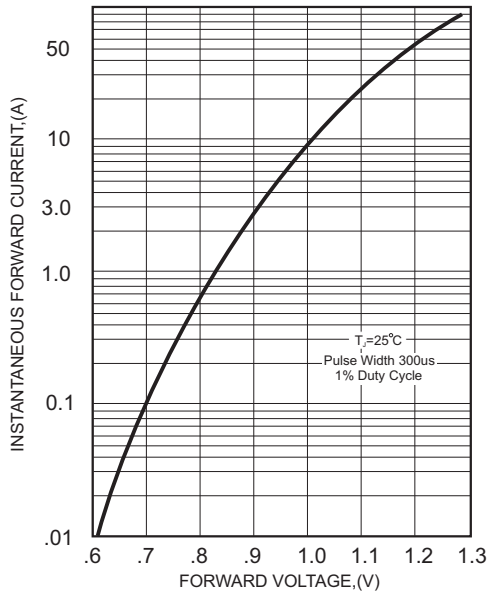

FIG.2-TYPICAL FORWARD CURRENT DERATING CURVE

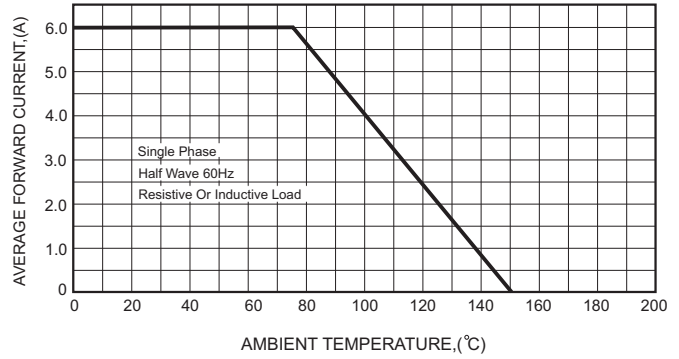

FIG.4-MAXIMUM NON-REPETITIVE FORWARD SURGE CURRENT

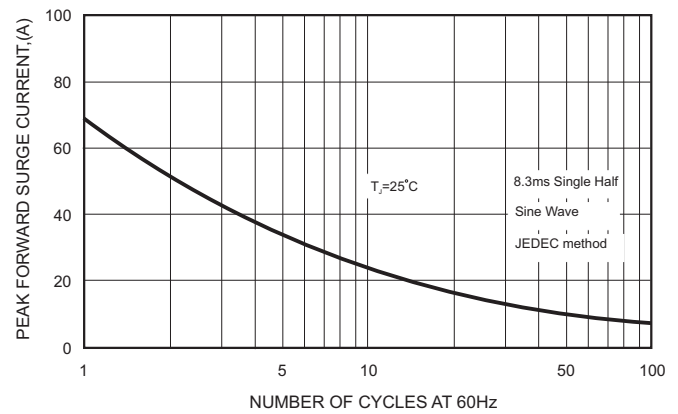

FIG.3 - TYPICAL REVERSE CHARACTERISTICS

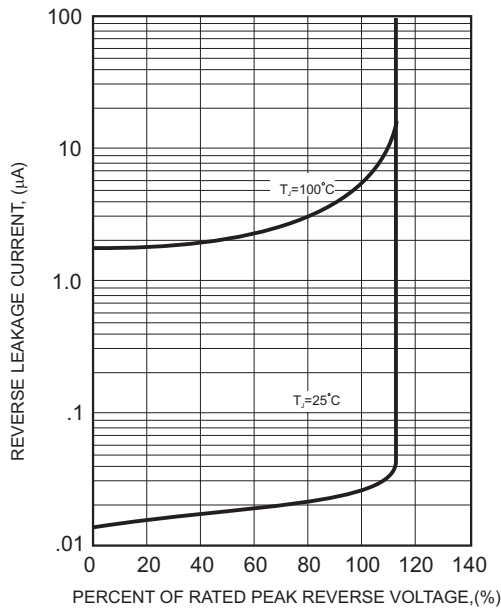

FIG.5-TYPICAL JUNCTION CAPACITANCE

