

OTP-Based 8-Bit Microcontroller**Devices Included in this Data Sheet:**

- FM8PB53B : OTP device

FEATURES

- Only 42 single word instructions
- All instructions are single cycle except for program branches which are two-cycle
- 13-bit wide instructions
- All OTP area GOTO instruction
- All OTP area subroutine CALL instruction
- 8-bit wide data path
- 5-level deep hardware stack
- Operating speed: DC-20 MHz clock input
DC-100 ns instruction cycle

Device	Pins #	I/O #	OTP (Word)	RAM (Byte)
FM8PB53B	14	12	1K	49

- Direct, indirect addressing modes for data accessing
- 8-bit real time clock/counter (Timer0) with 8-bit programmable prescaler
- Internal Power-on Reset (POR)
- Built-in Low Voltage Detector (LVD) for Brown-out Reset (BOR)
- Power-up Reset Timer (PWRT) and Oscillator Start-up Timer(OST)
- On chip Watchdog Timer (WDT) with internal oscillator for reliable operation and soft-ware watch-dog enable/disable control
- Two I/O ports IOA and IOB with independent direction control
- Soft-ware I/O pull-high/pull-down or open-drain control
- One internal interrupt source: Timer0 overflow; Two external interrupt source: INT pin, Port B input change
- Wake-up from SLEEP by INT pin or Port B input change
- Power saving SLEEP mode
- Built-in 8MHz, 4MHz, 1MHz, and 455KHz internal RC oscillator
- Programmable Code Protection
- Selectable oscillator options:
 - ERC: External Resistor/Capacitor Oscillator
 - HF: High Frequency Crystal/Resonator Oscillator
 - XT: Crystal/Resonator Oscillator
 - LF: Low Frequency Crystal Oscillator
 - IRC: Internal Resistor/Capacitor Oscillator
 - ERIC: External Resistor/Internal Capacitor Oscillator
- Operating voltage range: 2.0V to 5.5V
 - ≤4MHz: 2.4V to 5.5V
 - ≤8MHz: 2.6V to 5.5V, see 6.1 for more information.

GENERAL DESCRIPTION

The FM8PB53B is a low-cost, high speed, high noise immunity, OTP-based 8-bit CMOS microcontrollers. It employs a RISC architecture with only 42 instructions. All instructions are single cycle except for program branches which take two cycles. The easy to use and easy to remember instruction set reduces development time significantly.

The FM8PB53B consists of Power-on Reset (POR), Brown-out Reset (BOR), Power-up Reset Timer (PWRT), Oscillator Start-up Timer(OST), Watchdog Timer, OTP, SRAM, tri-state I/O port, I/O pull-high/open-drain/pull-down control, Power saving SLEEP mode, real time programmable clock/counter, Interrupt, Wake-up from SLEEP mode, and Code Protection for OTP products. There are three oscillator configurations to choose from, including the power-saving LF (Low Frequency) oscillator and cost saving RC oscillator.

The FM8PB53B address 1K×13 of program memory.

The FM8PB53B can directly or indirectly address its register files and data memory. All special function registers including the program counter are mapped in the data memory.

BLOCK DIAGRAM

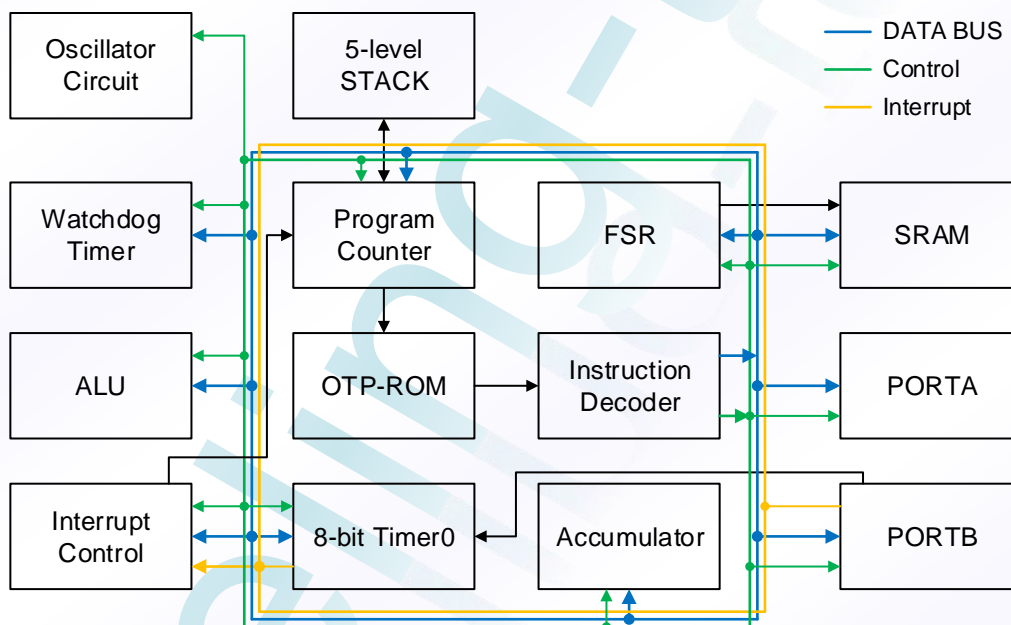

PIN CONNECTION

PDIP, SOP

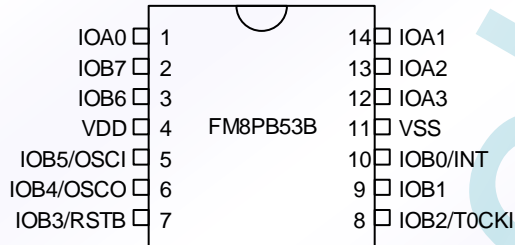

PIN DESCRIPTIONS

Name	I/O	Description
IOA0 ~ IOA3	I/O	<ul style="list-style-type: none"> IOA0 ~ IOA3 as bi-direction I/O pin Software controlled pull-down
IOB0/INT	I/O	<ul style="list-style-type: none"> Bi-direction I/O pin with system wake-up function Software controlled pull-high/open-drain/pull-down External interrupt input
IOB1	I/O	<ul style="list-style-type: none"> Bi-direction I/O pin with system wake-up function Software controlled pull-high/open-drain/pull-down
IOB2/T0CKI	I/O	<ul style="list-style-type: none"> Bi-direction I/O pin with system wake-up function Software controlled pull-high/open-drain/pull-down External clock input to Timer0
IOB3/RSTB	I/O	<ul style="list-style-type: none"> Input pin or open-drain output pin with system wake-up function System clear (RESET) input. Active low RESET to the device. Weak pull-high always on if configured as RSTB. Voltage on this pin must not exceed VDD, See IOB3 diagram for detail description.
IOB4/OSCO	I/O	<ul style="list-style-type: none"> Bi-direction I/O pin with system wake-up function (RCOUT optional in IRC/ERIC, ERC mode) Software controlled pull-high/open-drain Oscillator crystal output (HF, XT, LF mode) Outputs with the instruction cycle rate (RCOUT optional in IRC/ERIC, ERC mode)
IOB5/OSCI	I/O	<ul style="list-style-type: none"> Bi-direction I/O pin with system wake-up function (IRC mode) Software controlled pull-high/open-drain Oscillator crystal input (HF, XT, LF mode) External clock source input (ERIC, ERC mode)
IOB6 ~ IOB7	I/O	<ul style="list-style-type: none"> Bi-direction I/O pin with system wake-up function Software controlled pull-high/open-drain
Vdd	-	Positive supply
Vss	-	Ground

Legend: I=input, O=output, I/O=input/output

1.0 MEMORY ORGANIZATION

FM8PB53B memory is organized into program memory and data memory.

1.1 Program Memory Organization

The FM8PB53B has a 10-bit Program Counter capable of addressing a 1K×13 program memory space.

The RESET vector for the FM8PB53B is at 3FFh.

The H/W interrupt vector is at 008h. And the S/W interrupt vector is at 002h.

FM8PB53B supports all OTP area CALL/GOTO instructions without page.

Figure 1.1: Program Memory Map and STACK

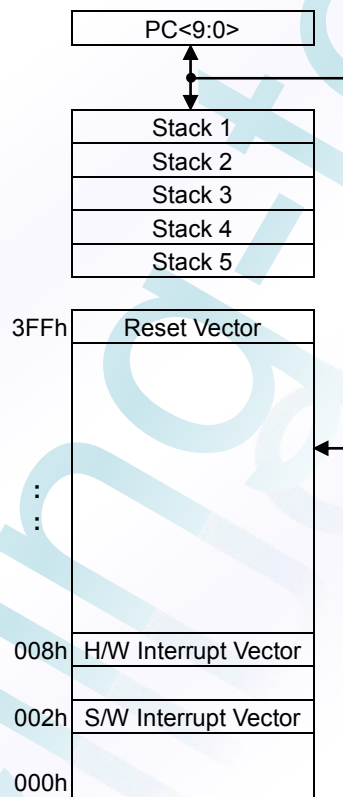

FM8PB53B

1.2 Data Memory Organization

Data memory is composed of Special Function Registers and General Purpose Registers.

The General Purpose Registers are accessed either directly or indirectly through the FSR register.

The Special Function Registers are registers used by the CPU and peripheral functions to control the operation of the device.

Table 1.1: Registers File Map for FM8PB53B

Address	Description
00h	INDF
01h	TMR0
02h	PCL
03h	STATUS
04h	FSR
05h	PORTA
06h	PORTB
07h	General Purpose Register
08h	PCON
09h	WUCON
0Ah	PCHBUF
0Bh	PDCON
0Ch	ODCON
0Dh	PHCON
0Eh	INTEN
0Fh	INTFLAG
10h ~ 3Fh	General Purpose Registers

N/A

OPTION

05h

IOSTA

06h

IOSTB

Table 1.2: The Registers Controlled by OPTION or IOST Instructions

Address	Name	B7	B6	B5	B4	B3	B2	B1	B0
N/A (w)	OPTION	*	INTEDG	T0CS	T0SE	PSA	PS2	PS1	PS0
05h (w)	IOSTA	Port A I/O Control Register							
06h (w)	IOSTB	Port B I/O Control Register							

Table 1.3: Operational Registers Map

Address	Name	B7	B6	B5	B4	B3	B2	B1	B0
00h (r/w)	INDF	Uses contents of FSR to address data memory (not a physical register)							
01h (r/w)	TMR0	8-bit real-time clock/counter							
02h (r/w)	PCL	Low order 8 bits of PC							
03h (r/w)	STATUS	RST	GP1	GP0	\overline{TO}	\overline{PD}	Z	DC	C
04h (r/w)	FSR	*	*	Indirect data memory address pointer					
05h (r/w)	PORTA					IOA3	IOA2	IOA1	IOA0
06h (r/w)	PORTB	IOB7	IOB6	IOB5	IOB4	IOB3	IOB2	IOB1	IOB0
07h (r/w)	SRAM	General Purpose Register							
08h (r/w)	PCON	WDTE	EIS	LVDTE	*	*	*	*	*
09h (r/w)	WUCON	WUB7	WUB6	WUB5	WUB4	WUB3	WUB2	WUB1	WUB0
0Ah (r/w)	PCHBUF	-	-	-	-	-	-	2 MSBs Buffer of PC	
0Bh (r/w)	PDCON		/PDB2	/PDB1	/PDB0	/PDA3	/PDA2	/PDA1	/PDA0
0Ch (r/w)	ODCON	ODB7	ODB6	ODB5	ODB4		ODB2	ODB1	ODB0
0Dh (r/w)	PHCON	/PHB7	/PHB6	/PHB5	/PHB4		/PHB2	/PHB1	/PHB0
0Eh (r/w)	INTEN	GIE	*	*	*	*	INTIE	PBIE	TOIE
0Fh (r/w)	INTFLAG	-	-	-	-	-	INTIF	PBIF	TOIF

Legend: - = unimplemented, read as '0', * = unimplemented, read as '1',

2.0 FUNCTIONAL DESCRIPTIONS

2.1 Operational Registers

2.1.1 INDF (Indirect Addressing Register)

Address	Name	B7	B6	B5	B4	B3	B2	B1	B0
00h (r/w)	INDF	Uses contents of FSR to address data memory (not a physical register)							

The INDF Register is not a physical register. Any instruction accessing the INDF register can actually access the register pointed by FSR Register. Reading the INDF register itself indirectly (FSR="0") will read 00h. Writing to the INDF register indirectly results in a no-operation (although status bits may be affected). The bits 5-0 of FSR register are used to select up to 64 registers (address: 00h ~ 3Fh).

Example 2.1: INDIRECT ADDRESSING

- Register file 38 contains the value 10h
- Register file 39 contains the value 0Ah
- Load the value 38 into the FSR Register
- A read of the INDF Register will return the value of 10h
- Increment the value of the FSR Register by one (@FSR=39h)
- A read of the INDF register now will return the value of 0Ah.

Figure 2.1: Direct/Indirect Addressing

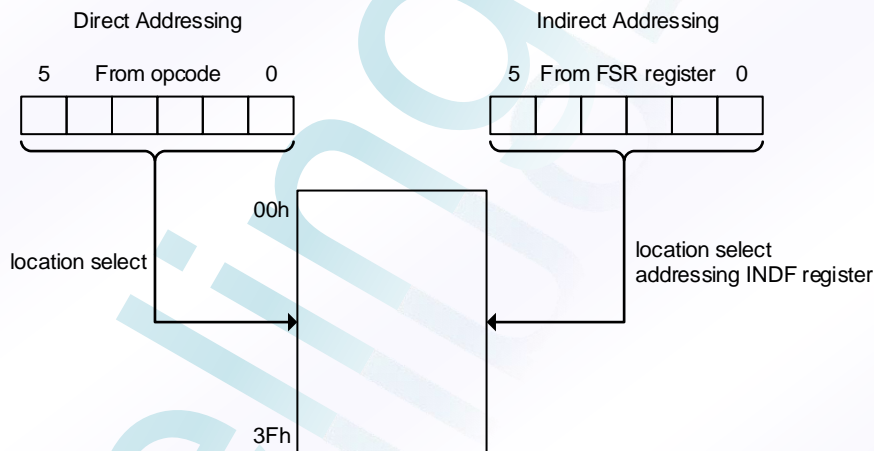

2.1.2 TMR0 (Time Clock/Counter register)

Address	Name	B7	B6	B5	B4	B3	B2	B1	B0
01h (r/w)	TMR0	8-bit real-time clock/counter							

The Timer0 is a 8-bit timer/counter. The clock source of Timer0 can come from the instruction cycle clock or by an external clock source (T0CKI pin) defined by T0CS bit (OPTION<5>). If T0CKI pin is selected, the Timer0 is increased by T0CKI signal rising/falling edge (selected by T0SE bit (OPTION<4>)).

The prescaler is assigned to Timer0 by clearing the PSA bit (OPTION<3>). In this case, the prescaler will be cleared when TMR0 register is written with a value.

2.1.3 PCL (Low Bytes of Program Counter) & Stack

Address	Name	B7	B6	B5	B4	B3	B2	B1	B0
02h (r/w)	PCL	Low order 8 bits of PC							

FM8PB53B device has a 10-bit wide Program Counter (PC) and five-level deep 10-bit hardware push/pop stack. The low byte of PC is called the PCL register. This register is readable and writable. The high byte of PC is called the PCH register. This register contains the PC<9:8> bits and is not directly readable or writable. All updates to the PCH register go through the PCHBUF register. As a program instruction is executed, the Program Counter will contain the address of the next program instruction to be executed. The PC value is increased by one, every instruction cycle, unless an instruction changes the PC.

For a GOTO instruction, the PC<9:0> is provided by the GOTO instruction word. The PCL register is mapped to PC<7:0>, and the PCHBUF register is not updated.

For a CALL instruction, the PC<9:0> is provided by the CALL instruction word. The next PC will be loaded (PUSHed) onto the top of STACK. The PCL register is mapped to PC<7:0>, and the PCHBUF register is not updated.

For a RETIA, RETFIE, or RETURN instruction, the PC are updated (POPed) from the top of STACK. The PCL register is mapped to PC<7:0>, and the PCHBUF register is not updated.

For any instruction where the PCL is the destination, the PC<7:0> is provided by the instruction word or ALU result. However, the PC<9:8> will come from the PCHBUF<1:0> bits (PCHBUF → PCH).

PCHBUF register is never updated with the contents of PCH.

Figure 2.2: Loading of PC in Different Situations

Situation 1: **GOTO** Instruction

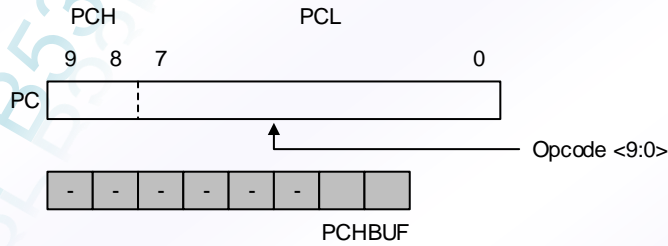

Situation 2: **CALL** Instruction

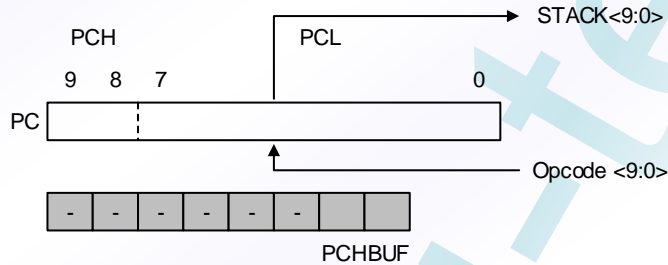

Situation 3: **RETIA**, **RETFIE**, or **RETURN** Instruction

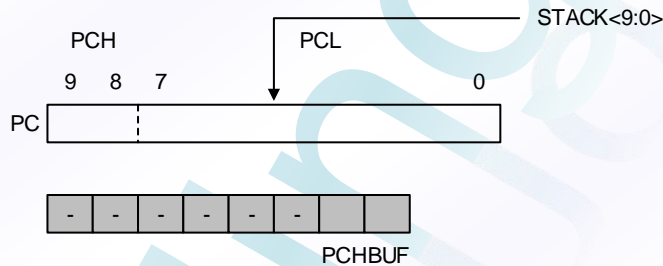

Situation 4: Instruction with PCL as destination

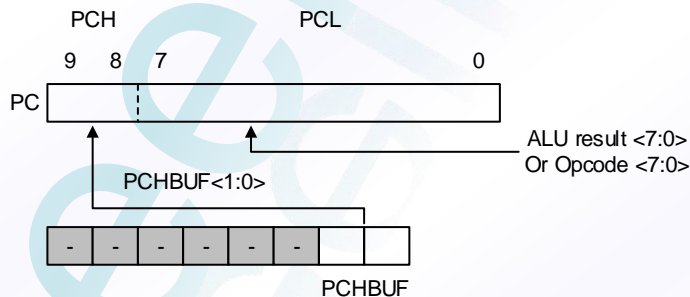

Note: PCHBUF is used only for instruction with PCL as destination for FM8PB53B.

2.1.4 STATUS (Status Register)

Address	Name	B7	B6	B5	B4	B3	B2	B1	B0
03h (r/w)	STATUS	RST	GP1	GP0	\overline{TO}	\overline{PD}	Z	DC	C

This register contains the arithmetic status of the ALU, the RESET status.

If the STATUS Register is the destination for an instruction that affects the Z, DC or C bits, then the write to these three bits is disabled. These bits are set or cleared according to the device logic. Furthermore, the \overline{TO} and \overline{PD} bits are not writable. Therefore, the result of an instruction with the STATUS Register as destination may be different than intended. For example, CLRR STATUS will clear the upper three bits and set the Z bit. This leaves the STATUS Register as 000u u1uu (where u = unchanged).

C : Carry/borrow bit.

ADDAR, ADDIA

= 1, Carry occurred.

= 0, No Carry occurred.

SUBAR, SUBIA

= 1, No borrow occurred.

= 0, Borrow occurred.

Note : A subtraction is executed by adding the two's complement of the second operand. For rotate (RRR, RLR) instructions, this bit is loaded with either the high or low order bit of the source register.

DC : Half carry/half borrow bit

ADDAR, ADDIA

= 1, Carry from the 4th low order bit of the result occurred.

= 0, No Carry from the 4th low order bit of the result occurred.

SUBAR, SUBIA

= 1, No Borrow from the 4th low order bit of the result occurred.

= 0, Borrow from the 4th low order bit of the result occurred.

Z : Zero bit.

= 1, The result of a logic operation is zero.

= 0, The result of a logic operation is not zero.

\overline{PD} : Power down flag bit.

= 1, after power-up or by the CLRWDT instruction.

= 0, by the SLEEP instruction.

\overline{TO} : Time overflow flag bit.

= 1, after power-up or by the CLRWDT or SLEEP instruction

= 0, a watch-dog time overflow occurred

GP1:GP0 : General purpose read/write bits.

RST : Bit for wake-up type.

= 1, Wake-up from SLEEP on Port B input change.

= 0, Wake-up from other reset types.

2.1.5 FSR (Indirect Data Memory Address Pointer)

Address	Name	B7	B6	B5	B4	B3	B2	B1	B0
04h (r/w)	FSR	*	*	Indirect data memory address pointer					

Bit5:Bit0 : Select registers address in the indirect addressing mode. See 2.1.1 for detail description.

Bit7:Bit6 : Not used. Read as "1"s.

2.1.6 PORTA, PORTB (Port Data Registers)

Address	Name	B7	B6	B5	B4	B3	B2	B1	B0
05h (r/w)	PORTA					IOA3	IOA2	IOA1	IOA0
06h (r/w)	PORTB	IOB7	IOB6	IOB5	IOB4	IOB3	IOB2	IOB1	IOB0

Reading the port (PORTA, PORTB register) reads the status of the pins independent of the pin's input/output modes. Writing to these ports will write to the port data latch.

PORTA is a 4-bit port data Register. Only the low order 4 bits are used (PORTA<3:0>). Bits 7-4 are general purpose read/write bits.

IOA3:IOA0 : PORTA I/O pin.
 = 1, Port pin is high level.
 = 0, Port pin is low level.

IOB7:IOB0 : PORTB I/O pin.
 = 1, Port pin is high level.
 = 0, Port pin is low level.
 Note: IOB3 is open-drain output only if IOSTB3 = 0. See 2.1.17 for detail description.

2.1.7 PCON (Power Control Register)

Address	Name	B7	B6	B5	B4	B3	B2	B1	B0
08h (r/w)	PCON	WDTE	EIS	LVDTE	*	*	*	*	*

Bit4:Bit0 : Not used. Read as "1"s.

LVDTE : LVDT (low voltage detector) enable bit.
 = 1, Enable LVDT.
 = 0, Disable LVDT.

EIS : Define the function of IOB0/INT pin.
 = 1, INT (external interrupt pin) is selected. In this case, the I/O control bit of IOB0 must be set to "1". The path of Port B input change of IOB0 pin is masked by hardware, the status of INT pin can also be read by way of reading PORTB.
 = 0, IOB0 (bi-directional I/O pin) is selected. The path of INT is masked.

WDTE : WDT (watch-dog timer) enable bit.
 = 1, Enable WDT.
 = 0, Disable WDT.

2.1.8 WUCON (Port B Input Change Interrupt/Wake-up Control Register)

Address	Name	B7	B6	B5	B4	B3	B2	B1	B0
09h (r/w)	WUCON	WUB7	WUB6	WUB5	WUB4	WUB3	WUB2	WUB1	WUB0

WUB0 : = 1, Enable the input change interrupt/wake-up function of IOB0 pin.
 = 0, Disable the input change interrupt/wake-up function of IOB0 pin.

WUB1 : = 1, Enable the input change interrupt/wake-up function of IOB1 pin.
 = 0, Disable the input change interrupt/wake-up function of IOB1 pin.

WUB2 : = 1, Enable the input change interrupt/wake-up function of IOB2 pin.
 = 0, Disable the input change interrupt/wake-up function of IOB2 pin.

WUB3 : = 1, Enable the input change interrupt/wake-up function of IOB3 pin.
 = 0, Disable the input change interrupt/wake-up function of IOB3 pin.

WUB4 : = 1, Enable the input change interrupt/wake-up function of IOB4 pin.
 = 0, Disable the input change interrupt/wake-up function of IOB4 pin.

WUB5 : = 1, Enable the input change interrupt/wake-up function of IOB5 pin.
 = 0, Disable the input change interrupt/wake-up function of IOB5 pin.

WUB6 : = 1, Enable the input change interrupt/wake-up function of IOB6 pin.
 = 0, Disable the input change interrupt/wake-up function of IOB6 pin.

WUB7 : = 1, Enable the input change interrupt/wake-up function of IOB7 pin.
 = 0, Disable the input change interrupt/wake-up function of IOB7 pin.

2.1.9 PCHBUF (High Byte Buffer of Program Counter)

Address	Name	B7	B6	B5	B4	B3	B2	B1	B0
0Ah (r/w)	PCHBUF	-	-	-	-	-	-	2 MSBs Buffer of PC	

Bit1:Bit0 : See 2.1.3 for detail description.

Bit7:Bit2 : Not used. Read as "0"s.

2.1.10 PDCON (Pull-down Control Register)

Address	Name	B7	B6	B5	B4	B3	B2	B1	B0
0Bh (r/w)	PDCON		/PDB2	/PDB1	/PDB0	/PDA3	/PDA2	/PDA1	/PDA0

/PDA0 : = 1, Disable the internal pull-down of IOA0 pin.
 = 0, Enable the internal pull-down of IOA0 pin.

/PDA1 : = 1, Disable the internal pull-down of IOA1 pin.
 = 0, Enable the internal pull-down of IOA1 pin.

/PDA2 : = 1, Disable the internal pull-down of IOA2 pin.
 = 0, Enable the internal pull-down of IOA2 pin.

/PDA3 : = 1, Disable the internal pull-down of IOA3 pin.
 = 0, Enable the internal pull-down of IOA3 pin.

/PDB0 : = 1, Disable the internal pull-down of IOB0 pin.
 = 0, Enable the internal pull-down of IOB0 pin.

/PDB1 : = 1, Disable the internal pull-down of IOB1 pin.
 = 0, Enable the internal pull-down of IOB1 pin.

/PDB2 : = 1, Disable the internal pull-down of IOB2 pin.
 = 0, Enable the internal pull-down of IOB2 pin.

Bit7 : General purpose read/write bit.

2.1.11 ODCON (Open-drain Control Register)

Address	Name	B7	B6	B5	B4	B3	B2	B1	B0
0Ch (r/w)	ODCON	ODB7	ODB6	ODB5	ODB4		ODB2	ODB1	ODB0

ODB0 : = 1, Enable the internal open-drain of IOB0 pin.
 = 0, Disable the internal open-drain of IOB0 pin.

ODB1 : = 1, Enable the internal open-drain of IOB1 pin.
 = 0, Disable the internal open-drain of IOB1 pin.

ODB2 : = 1, Enable the internal open-drain of IOB2 pin.
 = 0, Disable the internal open-drain of IOB2 pin.

Bit3 : General purpose read/write bit.

ODB4 : = 1, Enable the internal open-drain of IOB4 pin.
 = 0, Disable the internal open-drain of IOB4 pin.

ODB5 : = 1, Enable the internal open-drain of IOB5 pin.
 = 0, Disable the internal open-drain of IOB5 pin.

ODB6 : = 1, Enable the internal open-drain of IOB6 pin.
 = 0, Disable the internal open-drain of IOB6 pin.

ODB7 : = 1, Enable the internal open-drain of IOB7 pin.
 = 0, Disable the internal open-drain of IOB7 pin.

2.1.12 PHCON (Pull-high Control Register)

Address	Name	B7	B6	B5	B4	B3	B2	B1	B0
0Dh (r/w)	PHCON	/PHB7	/PHB6	/PHB5	/PHB4		/PHB2	/PHB1	/PHB0

/PHB0 : = 1, Disable the internal pull-high of IOB0 pin.
 = 0, Enable the internal pull-high of IOB0 pin.

/PHB1 : = 1, Disable the internal pull-high of IOB1 pin.
 = 0, Enable the internal pull-high of IOB1 pin.

/PHB2 : = 1, Disable the internal pull-high of IOB2 pin.
 = 0, Enable the internal pull-high of IOB2 pin.

Bit3 : General purpose read/write bit.

/PHB4 : = 1, Disable the internal pull-high of IOB4 pin.
 = 0, Enable the internal pull-high of IOB4 pin.

/PHB5 : = 1, Disable the internal pull-high of IOB5 pin.
 = 0, Enable the internal pull-high of IOB5 pin.

/PHB6 : = 1, Disable the internal pull-high of IOB6 pin.
 = 0, Enable the internal pull-high of IOB6 pin.

/PHB7 : = 1, Disable the internal pull-high of IOB7 pin.
 = 0, Enable the internal pull-high of IOB7 pin.

2.1.13 INTEN (Interrupt Mask Register)

Address	Name	B7	B6	B5	B4	B3	B2	B1	B0
0Eh (r/w)	INTEN	GIE	*	*	*	*	INTIE	PBIE	TOIE

TOIE : Timer0 overflow interrupt enable bit.
 = 1, Enable the Timer0 overflow interrupt.
 = 0, Disable the Timer0 overflow interrupt.

PBIE : Port B input change interrupt enable bit.
 = 1, Enable the Port B input change interrupt.
 = 0, Disable the Port B input change interrupt.

INTIE : External INT pin interrupt enable bit.
 = 1, Enable the External INT pin interrupt.
 = 0, Disable the External INT pin interrupt.

Bit6:Bit3 : Not used. Read as "1"s.

GIE : Global interrupt enable bit.
 = 1, Enable all un-masked interrupts. For wake-up from SLEEP mode through an interrupt event, the device will branch to the interrupt address (008h).
 = 0, Disable all interrupts. For wake-up from SLEEP mode through an interrupt event, the device will continue execution at the instruction after the SLEEP instruction.

Note : When an interrupt event occur with the GIE bit and its corresponding interrupt enable bit are all set, the GIE bit will be cleared by hardware to disable any further interrupts. The RETFIE instruction will exit the interrupt routine and set the GIE bit to re-enable interrupt.

2.1.14 INTFLAG (Interrupt Status Register)

Address	Name	B7	B6	B5	B4	B3	B2	B1	B0
0Fh (r/w)	INTFLAG	-	-	-	-	-	INTIF	PBIF	T0IF

T0IF : Timer0 overflow interrupt flag. Set when Timer0 overflows, reset by software.

PBIF : Port B input change interrupt flag. Set when Port B input changes, reset by software.

INTIF : External INT pin interrupt flag. Set by rising/falling (selected by INTEDG bit (OPTION<6>)) edge on INT pin, reset by software.

Bit7:Bit3 : Not used. Read as "0"s.

2.1.15 ACC (Accumulator)

Address	Name	B7	B6	B5	B4	B3	B2	B1	B0
N/A (r/w)	ACC	Accumulator							

Accumulator is an internal data transfer, or instruction operand holding. It cannot be addressed.

2.1.16 OPTION Register

Address	Name	B7	B6	B5	B4	B3	B2	B1	B0
N/A (w)	OPTION	*	INTEDG	T0CS	T0SE	PSA	PS2	PS1	PS0

Accessed by OPTION instruction.

By executing the OPTION instruction, the contents of the ACC Register will be transferred to the OPTION Register.

The OPTION Register is a 7-bit wide, write-only register which contains various control bits to configure the Timer0/WDT prescaler, Timer0, and the external INT interrupt.

The OPTION Register are "write-only" and are set all "1"s except INTEDG bit.

PS2:PS0 : Prescaler rate select bits.

PS2:PS0	Timer0 Rate	WDT Rate
0 0 0	1:2	1:1
0 0 1	1:4	1:2
0 1 0	1:8	1:4
0 1 1	1:16	1:8
1 0 0	1:32	1:16
1 0 1	1:64	1:32
1 1 0	1:128	1:64
1 1 1	1:256	1:128

PSA : Prescaler assign bit.

= 0, TMR0 (Timer0).

= 1, WDT (watch-dog timer).

T0SE : TMR0 source edge select bit.

= 0, Rising edge on T0CKI pin.

= 1, Falling edge on T0CKI pin.

T0CS : TMR0 clock source select bit.
 = 0, internal instruction clock cycle.
 = 1, External T0CKI pin. Pin IOB2/T0CKI is forced to be an input even if IOST IOB2 = "0".

INTEDG : Interrupt edge select bit.
 = 0, interrupt on falling edge of INT pin.
 = 1, interrupt on rising edge of INT pin.

Bit7 : Not used.

2.1.17 IOSTA & IOSTB (Port I/O Control Registers)

Address	Name	B7	B6	B5	B4	B3	B2	B1	B0
N/A (w)	IOSTA					IOSTA3	IOSTA2	IOSTA1	IOSTA0
N/A (w)	IOSTB	IOSTB7	IOSTB6	IOSTB5	IOSTB4	IOSTB3	IOSTB2	IOSTB1	IOSTB0

Accessed by IOST instruction.

The Port I/O Control Registers are loaded with the contents of the ACC Register by executing the IOST R (05h~06h) instruction.

The IOST Registers are "write-only" and are set (output drivers disabled) upon RESET.

IOSTA3:IOSTA0 : PORTA I/O control bit.
 = 1, PORTA pin configured as an input (tri-stated).
 = 0, PORTA pin configured as an output.

IOSTB7:IOSTB0 : PORTB I/O control bit.
 = 1, PORTB pin configured as an input (tri-stated).
 = 0, PORTB pin configured as an output.
 Note: 1. IOB3 is open-drain output only if IOSTB3 = 0.

2. **The IOB3 open-drain function will be fixed to "Disable" by H/W if the configuration bit IOB3OD= Disable, even if bit IOSTB3 = 0.**

2.2 I/O Ports

Port A and port B are bi-directional tri-state I/O ports. Port A is a 4-pin I/O port. Port B is a 8-pin I/O port. Please note that IOB3 is an input or open-drain output pin.

All I/O pins have data direction control registers (IOSTA, IOSTB) which can configure these pins as output or input. The exceptions are IOB2 which may be controlled by the T0CS bit (OPTION<5>).

IOB<7:4> and IOB<2:0> have its corresponding pull-high control bits (PHCON register) to enable the weak internal pull-high. The weak pull-high is automatically turned off when the pin is configured as an output pin.

IOA<3:0> and IOB<2:0> have its corresponding pull-down control bits (PDCON register) to enable the weak internal pull-down. The weak pull-down is automatically turned off when the pin is configured as an output pin.

IOB<7:4> and IOB<2:0> have its corresponding open-drain control bits (ODCON register) to enable the open-drain output when these pins are configured to be an output pin.

IOB<7:0> also provides the input change interrupt/wake-up function. Each pin has its corresponding input change interrupt/wake-up enable bits (WUCON) to select the input change interrupt/wake-up source.

The IOB0 is also an external interrupt input signal by setting the EIS bit (PCON<6>). In this case, IOB0 input change interrupt/wake-up function will be disabled by hardware even if it is enabled by software.

The CONFIGURATION words can set several I/Os to alternate functions. When acting as alternate functions the pins will read as "0" during port read.

Figure 2.3: Block Diagram of I/O Pins

IOA3 ~ IOA0:

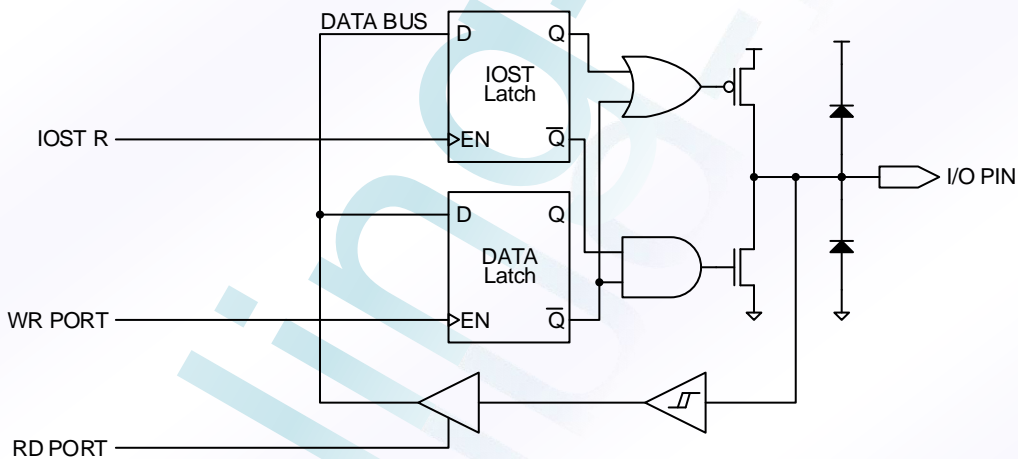

Pull-down is not shown in the figure

IOB0/INT:

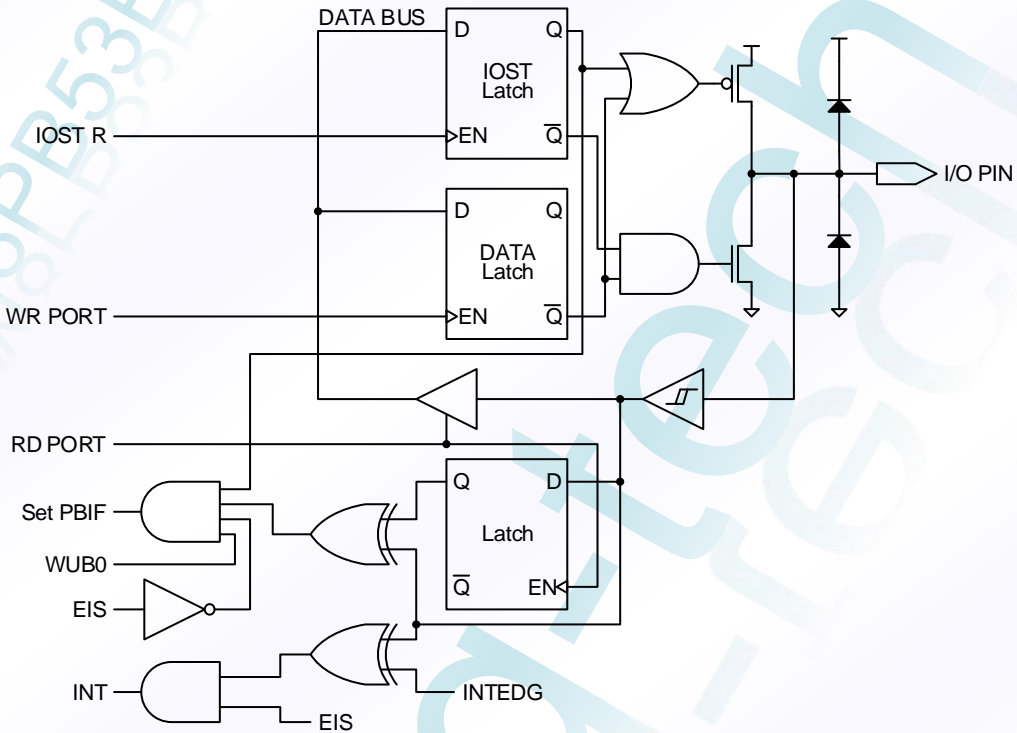

Pull-high/pull-down and open-drain are not shown in the figure

IOB3:

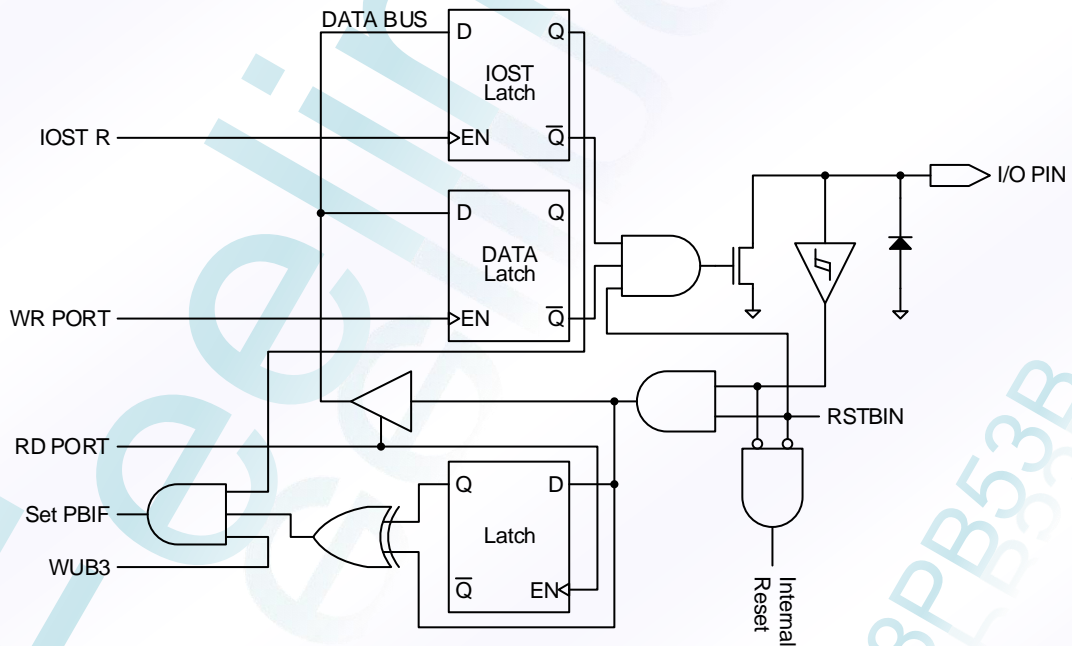

Voltage on this pin must not exceed VDD.

IOB7 ~ IOB4, IOB2 ~ IOB1:

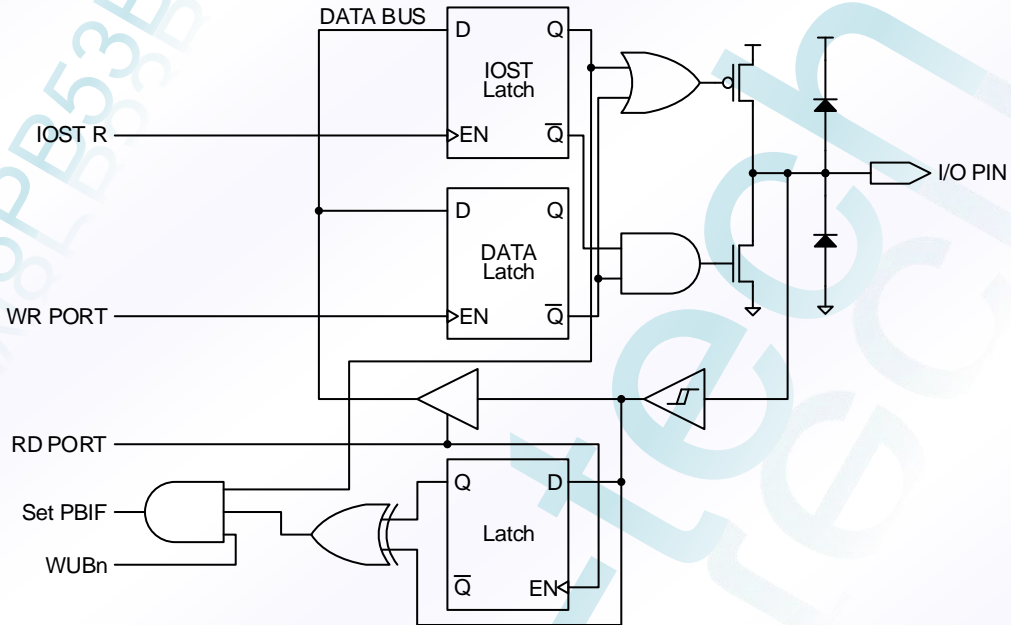

Pull-high/pull-down and open-drain are not shown in the figure

2.3 Timer0/WDT & Prescaler

2.3.1 Timer0

The Timer0 is a 8-bit timer/counter. The clock source of Timer0 can come from the internal clock or by an external clock source (T0CKI pin).

2.3.1.1 Using Timer0 with an Internal Clock: Timer mode

Timer mode is selected by clearing the T0CS bit (OPTION<5>). In timer mode, the timer0 register (TMR0) will increment every instruction cycle (without prescaler). If TMR0 register is written, the increment is inhibited for the following two cycles.

2.3.1.2 Using Timer0 with an External Clock: Counter mode

Counter mode is selected by setting the T0CS bit (OPTION<5>). In this mode, Timer0 will increment either on every rising or falling edge of pin T0CKI. The incrementing edge is determined by the source edge select bit T0SE (OPTION<4>).

The external clock requirement is due to internal phase clock (T_{osc}) synchronization. Also, there is a delay in the actual incrementing of Timer0 after synchronization.

When no prescaler is used, the external clock input is the same as the prescaler output. The synchronization of T0CKI with the internal phase clocks is accomplished by sampling the prescaler output on the T2 and T4 cycles of the internal phase clocks. Therefore, it is necessary for T0CKI to be high for at least $2 T_{osc}$ and low for at least $2 T_{osc}$.

When a prescaler is used, the external clock input is divided by the asynchronous prescaler. For the external clock to meet the sampling requirement, the ripple counter must be taken into account. Therefore, it is necessary for T0CKI to have a period of at least $4T_{osc}$ divided by the prescaler value.

2.3.2 Watchdog Timer (WDT)

The Watchdog Timer (WDT) is a free running on-chip RC oscillator which does not require any external components. So the WDT will still run even if the clock on the OSC1 and OSC0 pins is turned off, such as in SLEEP mode. During normal operation or in SLEEP mode, a WDT time-out will cause the device reset and the \overline{TO} bit (STATUS<4>) will be cleared.

The WDT can be disabled by clearing the control bit WDTE (PCON<7>) to "0".

The WDT has a nominal time-out period of 18ms, 4.5ms, 288ms or 72ms selected by SUT bit of configuration word (without prescaler). If a longer time-out period is desired, a prescaler with a division ratio of up to 1:128 can be assigned to the WDT controlled by the OPTION register. Thus, the longest time-out period is approximately 36.8 seconds.

The CLRWDT instruction clears the WDT and the prescaler, if assigned to the WDT, and prevents it from timing out and generating a device reset.

The SLEEP instruction resets the WDT and the prescaler, if assigned to the WDT. This gives the maximum SLEEP time before a WDT Wake-up Reset.

2.3.3 Prescaler

An 8-bit counter (down counter) is available as a prescaler for the Timer0, or as a postscaler for the Watchdog Timer (WDT). Note that the prescaler may be used by either the Timer0 module or the WDT, but not both. Thus, a prescaler assignment for the Timer0 means that there is no prescaler for the WDT, and vice-versa.

The PSA bit (OPTION<3>) determines prescaler assignment. The PS<2:0> bits (OPTION<2:0>) determine prescaler ratio.

When the prescaler is assigned to the Timer0 module, all instructions writing to the TMR0 register will clear the prescaler. When it is assigned to WDT, a CLRWDT instruction will clear the prescaler along with the WDT.

The prescaler is neither readable nor writable. On a RESET, the prescaler contains all '1's.

To avoid an unintended device reset, CLRWDT or CLRR TMR0 instructions must be executed when changing the

prescaler assignment from Timer0 to the WDT, and vice-versa.

Figure 2.4: Block Diagram of the Timer0/WDT Prescaler

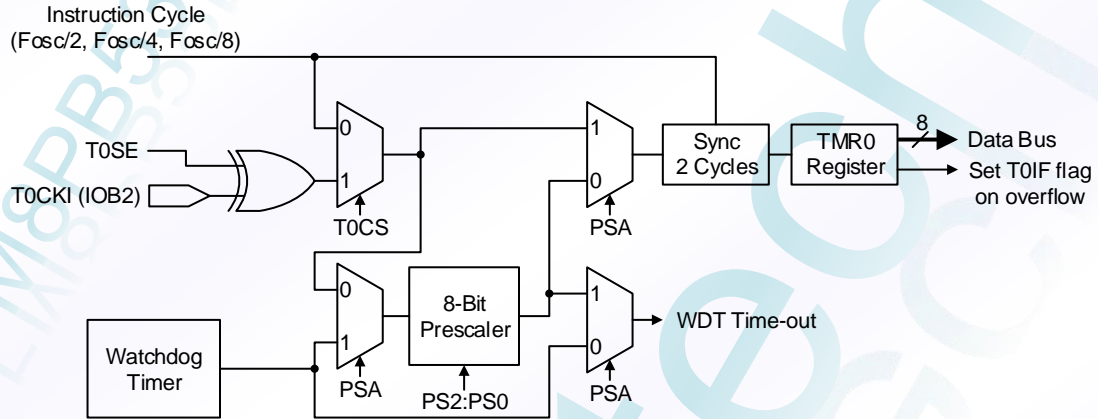

2.4 Interrupts

The FM8PB53B has up to three sources of interrupt:

1. External interrupt INT pin.
2. TMR0 overflow interrupt.
3. Port B input change interrupt (pins IOB7:IOB0).

INTFLAG is the interrupt flag register that recodes the interrupt requests in the relative flags.

A global interrupt enable bit, GIE (INTEN<7>), enables (if set) all un-masked interrupts or disables (if cleared) all interrupts. Individual interrupts can be enabled/disabled through their corresponding enable bits in INTEN register regardless of the status of the GIE bit.

When an interrupt event occur with the GIE bit and its corresponding interrupt enable bit are all set, the GIE bit will be cleared by hardware to disable any further interrupts, and the next instruction will be fetched from address 008h. The interrupt flag bits must be cleared by software before re-enabling GIE bit to avoid recursive interrupts. The RETFIE instruction exits the interrupt routine and set the GIE bit to re-enable interrupt.

The flag bit (except PBIF bit) in INTFLAG register is set by interrupt event regardless of the status of its mask bit. Reading the INTFLAG register will be the logic AND of INTFLAG and INTEN.

When an interrupt is generated by the INT instruction, the next instruction will be fetched from address 002h.

2.4.1 External INT Interrupt

External interrupt on INT pin is rising or falling edge triggered selected by INTEDG (OPTION<6>).

When a valid edge appears on the INT pin the flag bit INTIF (INTFLAG<2>) is set. This interrupt can be disabled by clearing INTIE bit (INTEN<2>).

The INT pin interrupt can wake-up the system from SLEEP condition, if bit INTIE was set before going to SLEEP. If GIE bit was set, the program will execute interrupt service routine after wake-up; or if GIE bit was cleared, the program will execute next PC after wake-up.

2.4.2 Timer0 Interrupt

An overflow (FFh → 00h) in the TMR0 register will set the flag bit TOIF (INTFLAG<0>). This interrupt can be disabled by clearing TOIE bit (INTEN<0>).

2.4.3 Port B Input Change Interrupt

An input change on IOB<7:0> set flag bit PBIF (INTFLAG<1>). This interrupt can be disabled by clearing PBIE bit (INTEN<1>).

Before the port B input change interrupt is enabled, reading PORTB (any instruction accessed to PORTB, including read/write instructions) is necessary. Any pin which corresponding WUBn bit (WUCON<7:0>) is cleared to "0" or configured as output or IOB0 pin configured as INT pin will be excluded from this function.

The port B input change interrupt also can wake-up the system from SLEEP condition, if bit PBIE was set before going to SLEEP. And GIE bit also decides whether or not the processor branches to the interrupt vector following wake-up. If GIE bit was set, the program will execute interrupt service routine after wake-up; or if GIE bit was cleared, the program will execute next PC after wake-up.

2.5 Power-down Mode (SLEEP)

Power-down mode is entered by executing a SLEEP instruction.

When SLEEP instruction is executed, the \overline{PD} bit (STATUS<3>) is cleared, the \overline{TO} bit is set, the watchdog timer will be cleared and keeps running, and the oscillator driver is turned off.

All I/O pins maintain the status they had before the SLEEP instruction was executed.

2.5.1 Wake-up from SLEEP Mode

The device can wake-up from SLEEP mode through one of the following events:

1. RSTB reset.
2. WDT time-out reset (if enabled).
3. Interrupt from RB0/INT pin, or PORTB change interrupt.

External RSTB reset and WDT time-out reset will cause a device reset. The \overline{PD} and \overline{TO} bits can be used to determine the cause of device reset. The \overline{PD} bit is set on power-up and is cleared when SLEEP instruction is executed. The \overline{TO} bit is cleared if a WDT time-out occurred.

For the device to wake-up through an interrupt event, the corresponding interrupt enable bit must be set. Wake-up is regardless of the GIE bit. If GIE bit is cleared, the device will continue execution at the instruction after the SLEEP instruction. If the GIE bit is set, the device will branch to the interrupt address (008h).

In HF or LF oscillation mode, the system wake-up delay time is 18/4.5/288/72ms (selected by SUT bit of configuration word).

And in IRC/ERIC or ERC oscillation mode, the system wake-up delay time is 140us.

2.6 Reset

FM8PB53B devices may be RESET in one of the following ways:

1. Power-on Reset (POR)
2. Brown-out Reset (BOR)
3. RSTB Pin Reset
4. WDT time-out Reset

Some registers are not affected in any RESET condition. Their status is unknown on Power-on Reset and unchanged in any other RESET. Most other registers are reset to a "reset state" on Power-on Reset, RSTB or WDT Reset.

A Power-on RESET pulse is generated on-chip when Vdd rise is detected. To use this feature, the user merely ties the RSTB pin to Vdd.

On-chip Low Voltage Detector (LVD) places the device into reset when Vdd is below a fixed voltage. This ensures that the device does not continue program execution outside the valid operation Vdd range. Brown-out RESET is typically used in AC line or heavy loads switched applications.

A RSTB or WDT Wake-up from SLEEP also results in a device RESET, and not a continuation of operation before SLEEP.

The \overline{TO} and \overline{PD} bits (STATUS<4:3>) are set or cleared depending on the different reset conditions.

2.6.1 Power-up Reset Timer (PWRT)

The Power-up Reset Timer provides a nominal 18/4.5/288/72ms (selected by SUT bit of configuration word) (or 650us, varies based on oscillator selection and reset condition) delay after Power-on Reset (POR), Brown-out

Reset (BOR), RSTB Reset or WDT time-out Reset. The device is kept in reset state as long as the PWRT is active.

The PWDT delay will vary from device to device due to Vdd, temperature, and process variation.

Table 2.1: PWRT Period

Oscillator Mode	Power-on Reset Brown-out Reset	RSTB Reset WDT time-out Reset
ERC & IRC/ERIC	18/4.5/288/72ms or 140us	140 us
HF & XT & LF	18/4.5/288/72ms	18/4.5/288/72ms

2.6.2 Oscillator Start-up Timer (OST)

The OST timer provides a 64 oscillator cycle delay (from OSCI input) after the PWRT delay (18/4.5/288/72ms or 140us) is over. This delay ensures that the X'tal oscillator or resonator has started and stabilized. The device is kept in reset state as long as the OST is active.

This counter only starts incrementing after the amplitude of the OSCI signal reaches the oscillator input thresholds.

2.6.3 Reset Sequence

When Power-on Reset (POR), Brown-out Reset (BOR), RSTB Reset or WDT time-out Reset is detected, the reset sequence is as follows:

1. The reset latch is set and the PWRT & OST are cleared.
2. When the internal POR, BOR, RSTB Reset or WDT time-out Reset pulse is finished, then the PWRT begins counting.
3. After the PWRT time-out, the OST is activated.
4. And after the OST delay is over, the reset latch will be cleared and thus end the on-chip reset signal.

In HF, XT or LF oscillation mode, the totally system reset delay time is 18/4.5/288/72ms plus 64 oscillator cycle time.

And in IRC/ERIC or ERC oscillation mode, the totally system reset delay time is 18/4.5/288/72ms or 140us after Power-on Reset (POR), Brown-out Reset (BOR), or 140us after RSTB Reset or WDT time-out Reset.

Figure 2.5: Simplified Block Diagram of on-chip Reset Circuit

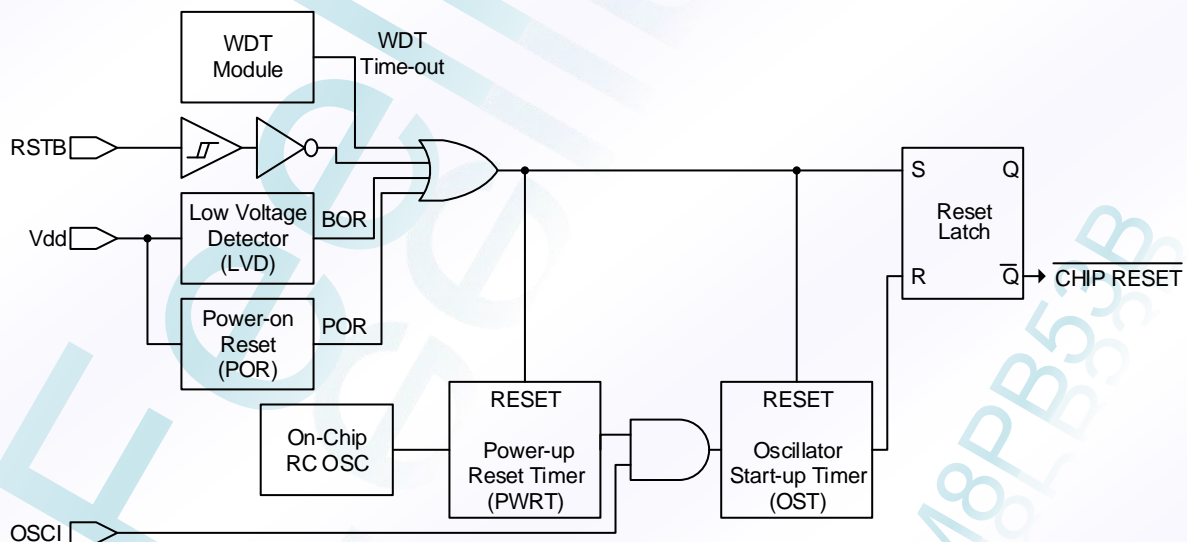

Table 2.2: Reset Conditions for All Registers

Register	Address	Power-on Reset Brown-out Reset	RSTB Reset WDT Reset
ACC	N/A	xxxx xxxx	uuuu uuuu
OPTION	N/A	-011 1111	-011 1111
IOSTA	N/A	---- 1111	---- 1111
IOSTB	N/A	1111 1111	1111 1111
INDF	00h	xxxx xxxx	uuuu uuuu
TMR0	01h	xxxx xxxx	uuuu uuuu
PCL	02h	1111 1111	1111 1111
STATUS	03h	0001 1xxx	000# #uuu
FSR	04h	11xx xxxx	11uu uuuu
PORTA	05h	xxxx xxxx	uuuu uuuu
PORTB	06h	xxxx xxxx	uuuu uuuu
General Purpose Register	07h	xxxx xxxx	uuuu uuuu
PCON	08h	101- ----	101- ----
WUCON	09h	0000 0000	0000 0000
PCHBUF	0Ah	---- --00	---- --00
PDCON	0Bh	1111 1111	1111 1111
ODCON	0Ch	0000 0000	0000 0000
PHCON	0Dh	1111 1111	1111 1111
INTEN	0Eh	0--- -000	0--- -000
INTFLAG	0Fh	---- -000	---- -000
General Purpose Registers	10 ~ 3Fh	xxxx xxxx	uuuu uuuu

Legend: u = unchanged, x = unknown, - = unimplemented,
= refer to the following table for possible values.

Table 2.3: RST / \overline{TO} / \overline{PD} Status after Reset or Wake-up

RST	\overline{TO}	\overline{PD}	RESET was caused by
0	1	1	Power-on Reset
0	1	1	Brown-out reset
0	u	u	RSTB Reset during normal operation
0	1	0	RSTB Reset during SLEEP
0	0	1	WDT Reset during normal operation
0	0	0	WDT Wake-up during SLEEP
1	1	0	Wake-up on pin change during SLEEP

Legend: u = unchanged

Table 2.4: Events Affecting \overline{TO} / \overline{PD} Status Bits

Event	\overline{TO}	\overline{PD}
Power-on	1	1
WDT Time-Out	0	u
SLEEP instruction	1	0
CLRWDI instruction	1	1

Legend: u = unchanged

2.7 Hexadecimal Convert to Decimal (HCD)

Decimal format is another number format for FM8PB53B. When the content of the data memory has been assigned as decimal format, it is necessary to convert the results to decimal format after the execution of ALU instructions. When the decimal converting operation is processing, all of the operand data (including the contents of the data memory (RAM), accumulator (ACC), immediate data, and look-up table) should be in the decimal format, or the results of conversion will be incorrect.

Instruction DAA can convert the ACC data from hexadecimal to decimal format after any addition operation and restored to ACC.

The conversion operation is illustrated in example 2.2.

Example 2.2: DAA CONVERSION

Address	Code
NA	#include <8PB53B.ASH>
n	...
n+1	MOVIA 0x90 ;Set immediate data = decimal format number "90" (ACC ← 90h)
n+2	MOVAR 0x30 ;Load immediate data "90" to data memory address 30H
n+3	MOVIA 0x10 ;Set immediate data = decimal format number "10" (ACC ← 10h)
n+4	ADDAR 0x30,A ;Contents of the data memory address 30H and ACC are binary-added ;the result loads to the ACC (ACC ← A0h, C ← 0)
n+5	DAA ;Convert the content of ACC to decimal format, and restored to ACC ;The result in the ACC is "00" and the carry bit C is "1". This represents the ;decimal number "100"
n+6	...

Instruction DAS can convert the ACC data from hexadecimal to decimal format after any subtraction operation and restored to ACC.

The conversion operation is illustrated in example 2.3.

Example 2.3: DAS CONVERSION

Address	Code
NA	#include <8PB53B.ASH>
n	...
n+1	MOVIA 0x10 ;Set immediate data = decimal format number "10" (ACC ← 10h)
n+2	MOVAR 0x30 ;Load immediate data "90" to data memory address 30H
n+3	MOVIA 0x20 ;Set immediate data = decimal format number "20" (ACC ← 20h)
n+4	SUBAR 0x30,A ;Contents of the data memory address 30H and ACC are binary-subtracted ;the result loads to the ACC (ACC ← F0h, C ← 0)
n+5	DAS ;Convert the content of ACC to decimal format, and restored to ACC ;The result in the ACC is "90" and the carry bit C is "0". This represents the ;decimal number " -10"
n+6	...

2.8 Oscillator Configurations

FM8PB53B can be operated in six different oscillator modes. Users can program F_{osc} configuration bit to select the appropriate modes:

- ERC: External Resistor/Capacitor Oscillator
- HF: High Frequency Crystal/Resonator Oscillator
- XT: Crystal/Resonator Oscillator
- LF: Low Frequency Crystal Oscillator
- IRC: Internal Resistor/Capacitor Oscillator
- ERIC: External Resistor/Internal Capacitor Oscillator

In LF, XT, or HF modes, a crystal or ceramic resonator is connected to the OSCI and OSCO pins to establish oscillation. When in LF, XT, or HF modes, the devices can have an external clock source drive the OSCI pin. The ERC device option offers additional cost savings for timing insensitive applications. The RC oscillator frequency is a function of the resistor (R_{ext}) and capacitor (C_{ext}), the operating temperature, and the process parameter.

The IRC/ERIC device option offers largest cost savings for timing insensitive applications. These devices offer 4 different internal RC oscillator frequency, 8 MHz, 4 MHz, 1 MHz, and 455 KHz, which is selected by configuration bit (F_{osc}). Or user can change the oscillator frequency with external resistor. The ERIC oscillator frequency is a function of the resistor (R_{ext}), the operating temperature, and the process parameter.

Figure 2.6: HF, XT or LF Oscillator Modes (Crystal Operation or Ceramic Resonator)

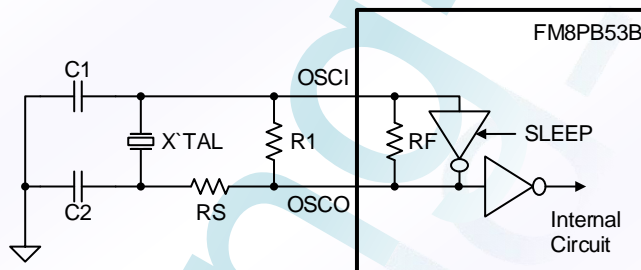

Figure 2.7: HF, XT or LF Oscillator Modes (External Clock Input Operation)

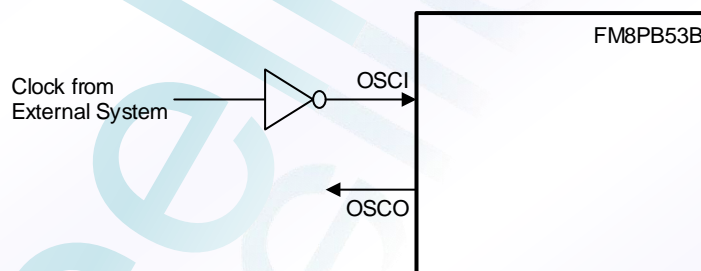

Figure 2.8: ERC Oscillator Mode (External RC Oscillator)

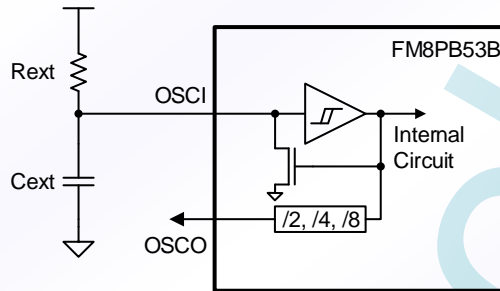
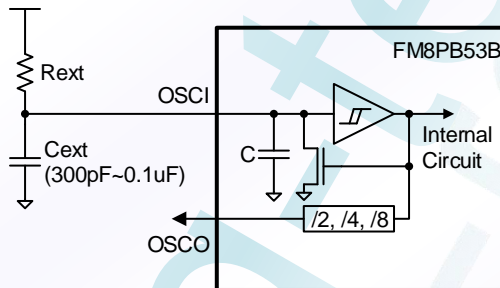

Figure 2.9: ERIC Oscillator Mode (External R, Internal C Oscillator)



The typical oscillator frequency vs. external resistor is as following table

Frequency	Rext @ 3V	Rext @ 5V
455KHz	910.5K	1212.1K
1MHz	565.6K	689.K
4MHz	187.6K	206.2K
8MHz	99.4K	103.2K
16MHz	47.9K	51.8K

Note: Values are provided for design reference only.

Figure 2.10: IRC Oscillator Mode (Internal R, Internal C Oscillator)

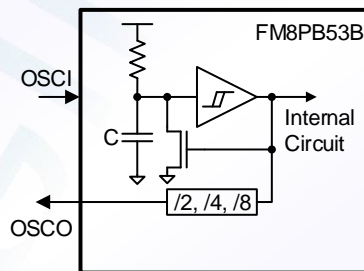

2.9 Configuration Words
Table 2.5: Configuration Words

Name	Description
Fosc	<p>Oscillator Selection Bit</p> <ul style="list-style-type: none"> → ERC mode (external R & C) (default) IOB4/OSCO pin controlled by OSCOUT configuration bit → HF mode → XT mode → LF mode → 4 MHz IRC mode (internal R & C) IOB4/OSCO pin controlled by OSCOUT configuration bit → 8 MHz IRC mode (internal R & C) IOB4/OSCO pin controlled by OSCOUT configuration bit → 1 MHz IRC mode (internal R & C) IOB4/OSCO pin controlled by OSCOUT configuration bit → 455 KHz IRC mode (internal R & C) IOB4/OSCO pin controlled by OSCOUT configuration bit → ERIC mode (external R & internal C) IOB4/OSCO pin controlled by OSCOUT configuration bit <p>Note: See Table 2.6 for detail description.</p>
LVDT	<p>Low Voltage Detector Selection Bit</p> <ul style="list-style-type: none"> → Enable, LVDT voltage = 3.6V (default) → Enable, LVDT voltage = 2.2V → Enable, LVDT voltage = 2.4V → Enable, LVDT voltage = 2.6V → Enable, LVDT voltage = 2.0V** → Enable, LVDT voltage = 1.8V** <p>Note: LVDT 2.0V only for LF and IRC 4MHz, 1MHz, 455KHz LVDT 1.8V only for LF and IRC 1MHz, 455KHz</p>
SUT	<p>PWRT & WDT Time Period Selection Bit (The value must be a multiple of prescaler rate)</p> <ul style="list-style-type: none"> → PWRT = WDT prescaler rate = 18ms (default) → PWRT = WDT prescaler rate = 4.5ms → PWRT = WDT prescaler rate = 288ms → PWRT = WDT prescaler rate = 72ms → PWRT = 140us, WDT prescaler rate = 18ms → PWRT = 140us, WDT prescaler rate = 4.5ms → PWRT = 140us, WDT prescaler rate = 288ms → PWRT = 140us, WDT prescaler rate = 72ms
OSCOUT	<p>IOB4/OSCO Pin Selection Bit for IRC/ERIC/ERC Mode</p> <ul style="list-style-type: none"> → OSCO pin is selected (default) → IOB4 pin is selected
RSTBIN	<p>IOB3/RSTB Pin Selection Bit</p> <ul style="list-style-type: none"> → IOB3 pin is selected (default) → RSTB pin is selected
WDTEN	<p>Watchdog Timer Enable Bit</p> <ul style="list-style-type: none"> → WDT enabled (default) → WDT disabled
PROTECT	<p>Code Protection Bit</p> <ul style="list-style-type: none"> → OTP code protection off (default) → OTP code protection on
OSCD	<p>Instruction Period Selection Bit</p> <ul style="list-style-type: none"> → Four oscillator periods (default) → Two oscillator periods → Eight oscillator periods

Name	Description
PMOD	Power Mode Selection Bit → Non-power saving (default) → Power saving
RDPORT	Read Port Control Bit for Output Pins → From registers (default) → From pins
SCHMITT	I/O Pin Input Buffer Control Bit → With Schmitt-trigger (default) → Without Schmitt-trigger
IOB3OD	IOB3 Pin Open-Drain Output Enable Bit → Enable open-drain function (IOB3 pin is Bi-direction) (default) → Disable open-drain function (IOB3 pin is Only input)

Table 2.6: Selection of IOB5/OSCI and IOB4/OSCO Pins

Mode of oscillation	IOB5/OSCI	IOB4/OSCO
IRC	Force to IOB5	IOB4/OSCO selected by OSCOUT bit
ERC, ERIC	Force to OSCI	IOB4/OSCO selected by OSCOUT bit
HF, XT, LF	Force to OSCI	Force to OSKO

3.0 INSTRUCTION SET

Mnemonic, Operands	Description	Operation	Cycles	Status Affected
BCR R, bit	Clear bit in R	$0 \rightarrow R$	1	-
BSR R, bit	Set bit in R	$1 \rightarrow R$	1	-
BTRSC R, bit	Test bit in R, Skip if Clear	Skip if $R = 0$	$1/2^{(1)}$	-
BTRSS R, bit	Test bit in R, Skip if Set	Skip if $R = 1$	$1/2^{(1)}$	-
NOP	No Operation	No operation	1	-
CLRWDT	Clear Watchdog Timer	$00h \rightarrow$ WDT, $00h \rightarrow$ WDT prescaler	1	$\overline{TO}, \overline{PD}$
SLEEP	Go into power-down mode	$00h \rightarrow$ WDT, $00h \rightarrow$ WDT prescaler	1	$\overline{TO}, \overline{PD}$
OPTION	Load OPTION register	$ACC \rightarrow$ OPTION	1	-
DAA	Adjust ACC's data format from HEX to DEC after any addition operation	$ACC(hex) \rightarrow$ ACC (dec)	1	C
DAS	Adjust ACC's data format from HEX to DEC after any subtraction operation	$ACC(hex) \rightarrow$ ACC (dec)	1	-
RETURN	Return from subroutine	Top of Stack \rightarrow PC	2	-
RETFIE	Return from interrupt, set GIE bit	Top of Stack \rightarrow PC, $1 \rightarrow$ GIE	2	-
INT	S/W interrupt	$PC + 1 \rightarrow$ Top of Stack $002h \rightarrow$ PC	2	-
IOST R	Load IOST register	$ACC \rightarrow$ IOST register	1	-
CLRA	Clear ACC	$00h \rightarrow$ ACC	1	Z
CLRR R	Clear R	$00h \rightarrow$ R	1	Z
MOVAR R	Move ACC to R	$ACC \rightarrow$ R	1	-
MOVR R, d	Move R	$R \rightarrow$ dest	1	Z
DECR R, d	Decrement R	$R - 1 \rightarrow$ dest	1	Z
DECRSZ R, d	Decrement R, Skip if 0	$R - 1 \rightarrow$ dest, Skip if result = 0	$1/2^{(1)}$	-
INCR R, d	Increment R	$R + 1 \rightarrow$ dest	1	Z
INCRSZ R, d	Increment R, Skip if 0	$R + 1 \rightarrow$ dest, Skip if result = 0	$1/2^{(1)}$	-
ADDAR R, d	Add ACC and R	$R + ACC \rightarrow$ dest	1	C, DC, Z
SUBAR R, d	Subtract ACC from R	$R - ACC \rightarrow$ dest	1	C, DC, Z
ADCAR R, d	Add ACC and R with Carry	$R + ACC + C \rightarrow$ dest	1	C, DC, Z
SBCAR R, d	Subtract ACC from R with Carry	$R + \overline{ACC} + C \rightarrow$ dest	1	C, DC, Z
ANDAR R, d	AND ACC with R	ACC and $R \rightarrow$ dest	1	Z
IORAR R, d	Inclusive OR ACC with R	ACC or $R \rightarrow$ dest	1	Z
XORAR R, d	Exclusive OR ACC with R	R xor $ACC \rightarrow$ dest	1	Z
COMR R, d	Complement R	$\overline{R} \rightarrow$ dest	1	Z
RLR R, d	Rotate left R through Carry	$R<7> \rightarrow$ C, $R<6:0> \rightarrow$ dest<7:1>, $C \rightarrow$ dest<0>	1	C
RRR R, d	Rotate right R through Carry	$C \rightarrow$ dest<7>, $R<7:1> \rightarrow$ dest<6:0>, $R<0> \rightarrow$ C	1	C
SWAPR R, d	Swap R	$R<3:0> \rightarrow$ dest<7:4>, $R<7:4> \rightarrow$ dest<3:0>	1	-

Mnemonic, Operands	Description	Operation	Cycles	Status Affected
MOVIA I	Move Immediate to ACC	I → ACC	1	-
ADDIA I	Add ACC and Immediate	I + ACC → ACC	1	C, DC, Z
SUBIA I	Subtract ACC from Immediate	I - ACC → ACC	1	C, DC, Z
ANDIA I	AND Immediate with ACC	ACC and I → ACC	1	Z
IORIA I	OR Immediate with ACC	ACC or I → ACC	1	Z
XORIA I	Exclusive OR Immediate to ACC	ACC xor I → ACC	1	Z
RETIA I	Return, place Immediate in ACC	I → ACC, Top of Stack → PC	2	-
CALL I	Call subroutine	PC + 1 → Top of Stack, I → PC	2	-
GOTO I	Unconditional branch	I → PC	2	-

- Note:
1. 2 cycles for skip, else 1 cycle.
 2. bit :Bit address within an 8-bit register R
R :Register address (00h to 3Fh)
I :Immediate data
ACC :Accumulator
d :Destination select;
=0 (store result in ACC)
=1 (store result in file register R)
dest :Destination
PC :Program Counter
PCH :High Byte register of Program Counter
WDT :Watchdog Timer Counter
GIE :Global interrupt enable bit
 \overline{TO} :Time-out bit
 \overline{PD} :Power-down bit
C :Carry bit
DC :Digital carry bit
Z :Zero bit

ADCAR Add ACC and R with Carry

Syntax: ADCAR R, d
Operands: $0 \leq R \leq 0x3F$
 $d \in [0,1]$
Operation: $R + ACC + C \rightarrow dest$
Status Affected: C, DC, Z
Description: Add the contents of the ACC register and register 'R' with Carry. If 'd' is 0 the result is stored in the ACC register. If 'd' is '1' the result is stored back in register 'R'.
Cycles: 1

ADDAR Add ACC and R

Syntax: ADDAR R, d
Operands: $0 \leq R \leq 0x3F$
 $d \in [0,1]$
Operation: $ACC + R \rightarrow dest$
Status Affected: C, DC, Z
Description: Add the contents of the ACC register and register 'R'. If 'd' is 0 the result is stored in the ACC register. If 'd' is '1' the result is stored back in register 'R'.
Cycles: 1

ADDIA Add ACC and Immediate

Syntax: ADDIA I
Operands: $0 \leq I \leq 0xFF$
Operation: $ACC + I \rightarrow ACC$
Status Affected: C, DC, Z
Description: Add the contents of the ACC register with the 8-bit immediate 'I'. The result is placed in the ACC register.
Cycles: 1

ANDAR AND ACC and R

Syntax: ANDAR R, d
Operands: $0 \leq R \leq 0x3F$
 $d \in [0,1]$
Operation: $ACC \text{ and } R \rightarrow dest$
Status Affected: Z
Description: The contents of the ACC register are AND'ed with register 'R'. If 'd' is 0 the result is stored in the ACC register. If 'd' is '1' the result is stored back in register 'R'.
Cycles: 1

ANDIA AND Immediate with ACC

Syntax: ANDIA I
Operands: $0 \leq I \leq 0xFF$
Operation: $ACC \text{ AND } I \rightarrow ACC$
Status Affected: Z
Description: The contents of the ACC register are AND'ed with the 8-bit immediate 'I'. The result is placed in the ACC register.
Cycles: 1

BCR **Clear Bit in R**

Syntax: BCR R, b
Operands: $0 \leq R \leq 0x3F$
 $0 \leq b \leq 7$
Operation: $0 \rightarrow R$
Status Affected: None
Description: Clear bit 'b' in register 'R'.
Cycles: 1

BSR **Set Bit in R**

Syntax: BSR R, b
Operands: $0 \leq R \leq 0x3F$
 $0 \leq b \leq 7$
Operation: $1 \rightarrow R$
Status Affected: None
Description: Set bit 'b' in register 'R'.
Cycles: 1

BTRSC **Test Bit in R, Skip if Clear**

Syntax: BTRSC R, b
Operands: $0 \leq R \leq 0x3F$
 $0 \leq b \leq 7$
Operation: Skip if $R = 0$
Status Affected: None
Description: If bit 'b' in register 'R' is 0 then the next instruction is skipped.
If bit 'b' is 0 then next instruction fetched during the current instruction execution is discarded, and a NOP is executed instead making this a 2-cycle instruction.
Cycles: 1/2

BTRSS **Test Bit in R, Skip if Set**

Syntax: BTRSS R, b
Operands: $0 \leq R \leq 0x3F$
 $0 \leq b \leq 7$
Operation: Skip if $R = 1$
Status Affected: None
Description: If bit 'b' in register 'R' is '1' then the next instruction is skipped.
If bit 'b' is '1', then the next instruction fetched during the current instruction execution, is discarded and a NOP is executed instead, making this a 2-cycle instruction.
Cycles: 1/2

CALL **Subroutine Call**

Syntax: CALL I
Operands: $0 \leq I \leq 0x3FF$
Operation: $PC + 1 \rightarrow$ Top of Stack;
 $I \rightarrow PC$
Status Affected: None
Description: Subroutine call. First, return address (PC+1) is pushed onto the stack. The 10-bit immediate address is loaded into PC bits <9:0>. CALL is a 2-cycle instruction.
Cycles: 2

CLRA	Clear ACC
Syntax:	CLRA
Operands:	None
Operation:	00h → ACC; 1 → Z
Status Affected:	Z
Description:	The ACC register is cleared. Zero bit (Z) is set.
Cycles:	1
CLRR	Clear R
Syntax:	CLRR R
Operands:	$0 \leq R \leq 0x3F$
Operation:	00h → R; 1 → Z
Status Affected:	Z
Description:	The contents of register 'R' are cleared and the Z bit is set.
Cycles:	1
CLRWDT	Clear Watchdog Timer
Syntax:	CLRWDT
Operands:	None
Operation:	00h → WDT; 00h → WDT prescaler (if assigned); 1 → \overline{TO} ; 1 → \overline{PD}
Status Affected:	\overline{TO} , \overline{PD}
Description:	The CLRWDT instruction resets the WDT. It also resets the prescaler, if the prescaler is assigned to the WDT and not Timer0. Status bits \overline{TO} and \overline{PD} are set.
Cycles:	1
COMR	Complement R
Syntax:	COMR R, d
Operands:	$0 \leq R \leq 0x3F$ $d \in [0,1]$
Operation:	$\overline{R} \rightarrow \text{dest}$
Status Affected:	Z
Description:	The contents of register 'R' are complemented. If 'd' is 0 the result is stored in the ACC register. If 'd' is 1 the result is stored back in register 'R'.
Cycles:	1
DAA	Adjust ACC's data format from HEX to DEC
Syntax:	DAA
Operands:	None
Operation:	ACC(hex) → ACC(dec)
Status Affected:	C
Description:	Convert the ACC data from hexadecimal to decimal format after any addition operation and restored to ACC.
Cycles:	1

DAS	Adjust ACC's data format from HEX to DEC
Syntax:	DAS
Operands:	None
Operation:	ACC(hex) → ACC(dec)
Status Affected:	None
Description:	Convert the ACC data from hexadecimal to decimal format after any subtraction operation and restored to ACC.
Cycles:	1
DECR	Decrement R
Syntax:	DECR R, d
Operands:	0 ≤ R ≤ 0x3F d ∈ [0,1]
Operation:	R - 1 → dest
Status Affected:	Z
Description:	Decrement of register 'R'. If 'd' is 0 the result is stored in the ACC register. If 'd' is 1 the result is stored back in register 'R'.
Cycles:	1
DECRSZ	Decrement R, Skip if 0
Syntax:	DECRSZ R, d
Operands:	0 ≤ R ≤ 0x3F d ∈ [0,1]
Operation:	R - 1 → dest; skip if result = 0
Status Affected:	None
Description:	The contents of register 'R' are decrement. If 'd' is 0 the result is placed in the ACC register. If 'd' is 1 the result is stored back in register 'R'. If the result is 0, the next instruction, which is already fetched, is discarded and a NOP is executed instead and making it a 2-cycle instruction.
Cycles:	1/2
GOTO	Unconditional Branch
Syntax:	GOTO I
Operands:	0 ≤ I ≤ 0x3FF
Operation:	I → PC
Status Affected:	None
Description:	GOTO is an unconditional branch. The 10-bit immediate value is loaded into PC bits <9:0>. GOTO is a 2-cycle instruction.
Cycles:	2
INCR	Increment R
Syntax:	INCR R, d
Operands:	0 ≤ R ≤ 0x3F d ∈ [0,1]
Operation:	R + 1 → dest
Status Affected:	Z
Description:	The contents of register 'R' are increment. If 'd' is 0 the result is placed in the ACC register. If 'd' is 1 the result is stored back in register 'R'.
Cycles:	1

INCRSZ Increment R, Skip if 0

Syntax: INCRSZ R, d
 Operands: $0 \leq R \leq 0x3F$
 $d \in [0,1]$
 Operation: $R + 1 \rightarrow \text{dest}$, skip if result = 0
 Status Affected: None
 Description: The contents of register 'R' are increment. If 'd' is 0 the result is placed in the ACC register. If 'd' is 1 the result is stored back in register 'R'.
 If the result is 0, then the next instruction, which is already fetched, is discarded and a NOP is executed instead and making it a 2-cycle instruction.
 Cycles: 1/2

INT S/W Interrupt

Syntax: INT
 Operands: None
 Operation: $PC + 1 \rightarrow \text{Top of Stack}$,
 $002h \rightarrow PC$
 Status Affected: None
 Description: Interrupt subroutine call. First, return address (PC+1) is pushed onto the stack. The address 002h is loaded into PC bits <9:0>.
 Cycles: 2

IORAR OR ACC with R

Syntax: IORAR R, d
 Operands: $0 \leq R \leq 0x3F$
 $d \in [0,1]$
 Operation: $ACC \text{ or } R \rightarrow \text{dest}$
 Status Affected: Z
 Description: Inclusive OR the ACC register with register 'R'. If 'd' is 0 the result is placed in the ACC register. If 'd' is 1 the result is placed back in register 'R'.
 Cycles: 1

IORIA OR Immediate with ACC

Syntax: IORIA I
 Operands: $0 \leq I \leq 0xFF$
 Operation: $ACC \text{ or } I \rightarrow ACC$
 Status Affected: Z
 Description: The contents of the ACC register are OR'ed with the 8-bit immediate 'I'. The result is placed in the ACC register.
 Cycles: 1

IOST Load IOST Register

Syntax: IOST R
 Operands: $R = 0x05 \text{ or } 0x06$
 Operation: $ACC \rightarrow \text{IOST register } R$
 Status Affected: None
 Description: IOST register 'R' ($R = 0x05 \text{ or } 0x06$) is loaded with the contents of the ACC register.
 Cycles: 1

MOVAR Move ACC to R

Syntax: MOVAR R
Operands: $0 \leq R \leq 0x3F$
Operation: ACC \rightarrow R
Status Affected: None
Description: Move data from the ACC register to register 'R'.
Cycles: 1

MOVIA Move Immediate to ACC

Syntax: MOVIA I
Operands: $0 \leq I \leq 0xFF$
Operation: I \rightarrow ACC
Status Affected: None
Description: The 8-bit immediate 'I' is loaded into the ACC register. The don't cares will assemble as 0s.
Cycles: 1

MOVR Move R

Syntax: MOVR R, d
Operands: $0 \leq R \leq 0x3F$
 $d \in [0,1]$
Operation: R \rightarrow dest
Status Affected: Z
Description: The contents of register 'R' is moved to destination 'd'. If 'd' is 0, destination is the ACC register. If 'd' is 1, the destination is file register 'R'. 'd' is 1 is useful to test a file register since status flag Z is affected.
Cycles: 1

NOP No Operation

Syntax: NOP
Operands: None
Operation: No operation
Status Affected: None
Description: No operation.
Cycles: 1

OPTION Load OPTION Register

Syntax: OPTION
Operands: None
Operation: ACC \rightarrow OPTION
Status Affected: None
Description: The content of the ACC register is loaded into the OPTION register.
Cycles: 1

RETFIE Return from Interrupt, Set 'GIE' Bit

Syntax: RETFIE
Operands: None
Operation: Top of Stack \rightarrow PC
 1 \rightarrow GIE
Status Affected: None
Description: The program counter is loaded from the top of the stack (the return address). The 'GIE' bit is set to 1. This is a 2-cycle instruction.
Cycles: 2

RETIA Return with Immediate in ACC

Syntax: RETIA I
Operands: $0 \leq I \leq 0xFF$
Operation: I → ACC;
 Top of Stack → PC
Status Affected: None
Description: The ACC register is loaded with the 8-bit immediate 'I'. The program counter is loaded from the top of the stack (the return address). This is a 2-cycle instruction.
Cycles: 2

RETURN Return from Subroutine

Syntax: RETURN
Operands: None
Operation: Top of Stack → PC
Status Affected: None
Description: The program counter is loaded from the top of the stack (the return address). This is a two-cycle instruction.
Cycles: 2

RLR Rotate Left R through Carry

Syntax: RLR R, d
Operands: $0 \leq R \leq 0x3F$
 $d \in [0,1]$
Operation: R<7> → C;
 R<6:0> → dest<7:1>;
 C → dest<0>
Status Affected: C
Description: The contents of register 'R' are rotated left one bit to the left through the Carry Flag. If 'd' is 0 the result is placed in the ACC register. If 'd' is 1 the result is stored back in register 'R'.
Cycles: 1

RRR Rotate Right R through Carry

Syntax: RRR R, d
Operands: $0 \leq R \leq 0x3F$
 $d \in [0,1]$
Operation: C → dest<7>;
 R<7:1> → dest<6:0>;
 R<0> → C
Status Affected: C
Description: The contents of register 'R' are rotated one bit to the right through the Carry Flag. If 'd' is 0 the result is placed in the ACC register. If 'd' is 1 the result is placed back in register 'R'.
Cycles: 1

SLEEP	Enter SLEEP Mode
Syntax:	SLEEP
Operands:	None
Operation:	00h → WDT; 00h → WDT prescaler; 1 → \overline{TO} ; 0 → \overline{PD}
Status Affected:	$\overline{TO}, \overline{PD}$
Description:	Time-out status bit (\overline{TO}) is set. The power-down status bit (\overline{PD}) is cleared. The WDT and its prescaler cleared. The processor is put into SLEEP mode.
Cycles:	1
SBCAR	Subtract ACC from R with Carry
Syntax:	SBCAR R, d
Operands:	$0 \leq R \leq 0x3F$ $d \in [0,1]$
Operation:	$R + \overline{ACC} + C \rightarrow \text{dest}$
Status Affected:	C, DC, Z
Description:	Add the 2's complement data of the ACC register from register 'R' with Carry. If 'd' is 0 the result is stored in the ACC register. If 'd' is 1 the result is stored back in register 'R'.
Cycles:	1
SUBAR	Subtract ACC from R
Syntax:	SUBAR R, d
Operands:	$0 \leq R \leq 0x3F$ $d \in [0,1]$
Operation:	$R - ACC \rightarrow \text{dest}$
Status Affected:	C, DC, Z
Description:	Subtract (2's complement method) the ACC register from register 'R'. If 'd' is 0 the result is stored in the ACC register. If 'd' is 1 the result is stored back in register 'R'.
Cycles:	1
SUBIA	Subtract ACC from Immediate
Syntax:	SUBIA I
Operands:	$0 \leq I \leq 0xFF$
Operation:	$I - ACC \rightarrow ACC$
Status Affected:	C, DC, Z
Description:	Subtract (2's complement method) the ACC register from the 8-bit immediate 'I'. The result is placed in the ACC register.
Cycles:	1
SWAPR	Swap nibbles in R
Syntax:	SWAPR R, d
Operands:	$0 \leq R \leq 0x3F$ $d \in [0,1]$
Operation:	$R<3:0> \rightarrow \text{dest}<7:4>;$ $R<7:4> \rightarrow \text{dest}<3:0>$
Status Affected:	None
Description:	The upper and lower nibbles of register 'R' are exchanged. If 'd' is 0 the result is placed in ACC register. If 'd' is 1 the result in placed in register 'R'.
Cycles:	1

XORAR Exclusive OR ACC with R

Syntax: XORAR R, d

Operands: $0 \leq R \leq 0x3F$
 $d \in [0,1]$ Operation: ACC xor R \rightarrow dest

Status Affected: Z

Description: Exclusive OR the contents of the ACC register with register 'R'. If 'd' is 0 the result is stored in the ACC register. If 'd' is 1 the result is stored back in register 'R'.

Cycles: 1

XORIA Exclusive OR Immediate with ACC

Syntax: XORIA I

Operands: $0 \leq I \leq 0xFF$ Operation: ACC xor I \rightarrow ACC

Status Affected: Z

Description: The contents of the ACC register are XOR'ed with the 8-bit immediate 'I'. The result is placed in the ACC register.

Cycles: 1

4.0 ABSOLUTE MAXIMUM RATINGS

Ambient Operating Temperature	0°C to +70°C
Store Temperature	-65°C to +150°C
DC Supply Voltage (Vdd)	0V to +6.0V
Input Voltage with respect to Ground (Vss)	-0.3V to (Vdd + 0.3)V

5.0 OPERATING CONDITIONS

DC Supply Voltage	+2.0V to +5.5V*
Operating Temperature	0°C to +70°C

*: See 6.1 for detail description.

6.0 ELECTRICAL CHARACTERISTICS

6.1 ELECTRICAL CHARACTERISTICS of FM8PB53B

Ta=25°C

Under Operating Conditions, at four clock instruction cycles and WDT & LVDT are disabled

Sym	Description	Conditions	Min.	Typ.	Max.	Unit	
V _{DD}	Supply voltage	0Hz ~ 1MHz		2.0	5.5	V	
		1MHz ~ 4MHz		2.0	5.5		
		4MHz ~ 8MHz		2.4	5.5		
		8MHz ~ 10MHz		2.6	5.5		
		10MHz ~ 16MHz		3.0	5.5		
		16MHz ~ 20MHz		3.5	5.5		
T _{PWR}	Power rising time	Vdd=0V to Vdd	0.8		2.6	ms/V	
F _{HF}	X'tal oscillation range	HF mode, Vdd=5V	4		20	MHz	
		HF mode, Vdd=3V	4		16		
F _{XT}	X'tal oscillation range	XT mode, Vdd=5V	0.455		20	MHz	
		XT mode, Vdd=3V	0.455		8		
F _{LF}	X'tal oscillation range	LF mode, Vdd=5V	32		455	KHz	
		LF mode, Vdd=3V	32		455		
F _{ERC}	RC oscillation range	ERC mode, Vdd=5V	DC		16	MHz	
		ERC mode, Vdd=3V	DC		13		
F _{IRC/ERIC}	RC oscillation range	ERIC mode, external R, Vdd=5V	DC		16	MHz	
		ERIC mode, external R, Vdd=3V	DC		16		
		IRC mode, internal R, Vdd=5V	0.455		8		
		IRC mode, internal R, Vdd=3V	0.455		8		
V _{IH}	Input high voltage	With Schmitt-trigger					V
		I/O ports, Vdd=5V	2.2		VDD		
		RSTB, T0CKI pins, Vdd=5V	2.2		VDD		
		I/O ports, Vdd=3V	1.7		VDD		
		RSTB, T0CKI pins, Vdd=3V	1.7		VDD		
		Without Schmitt-trigger					
		I/O ports, Vdd=5V	2.0		VDD		
		RSTB, T0CKI pins, Vdd=5V	2.0		VDD		
		I/O ports, Vdd=3V	1.5		VDD		
		RSTB, T0CKI pins, Vdd=3V	1.5		VDD		
V _{IL}	Input low voltage	With Schmitt-trigger					V
		I/O ports, Vdd=5V	VSS		0.8		
		RSTB, T0CKI pins, Vdd=5V	VSS		0.8		
		I/O ports, Vdd=3V	VSS		0.5		
		RSTB, T0CKI pins, Vdd=3V	VSS		0.5		
		Without Schmitt-trigger					
		I/O ports, Vdd=5V	VSS		1.0		
		RSTB, T0CKI pins, Vdd=5V	VSS		1.0		
		I/O ports, Vdd=3V	VSS		0.6		
		RSTB, T0CKI pins, Vdd=3V	VSS		0.6		

Sym	Description	Conditions	Min.	Typ.	Max.	Unit	
V _{OH}	Output high voltage	I _{OH} =-5.4mA, V _{dd} =5V	3.6			V	
V _{OL}	Output low voltage	I _{OL} =8.7mA, V _{dd} =5V			0.6	V	
I _{PH}	Pull-high current	Input pin at V _{ss} , V _{dd} =5V	-50	-66	-80	uA	
I _{PD}	Pull-down current	Input pin at V _{dd} , V _{dd} =5V	30	44	60	uA	
I _{WDT}	WDT current	V _{dd} =5V		6		uA	
		V _{dd} =3V		1.5			
T _{WDT}	WDT period	V _{dd} =3V		20.2		mS	
		V _{dd} =4V		17.5			
		V _{dd} =5V		15.9			
I _{LVDT}	LVDT current	V _{dd} =5V LVDT = 3.6V		1.89		uA	
		V _{dd} =5V LVDT = 2.4V		2.4			
		V _{dd} =3V LVDT = 2.4V		1			
I _{SB}	Power down current	Sleep mode, V _{dd} =5V, WDT LVDT disable		0.2	0.5	uA	
		Sleep mode, V _{dd} =3V, WDT LVDT disable		0.1	0.3		
I _{DD}	Operating current	HF mode, V _{dd} =5V, 4 clock instruction, OSCI / OSCO =20pF / 20pF					mA
		20MHz		3.03			
		16MHz		2.61			
		HF mode, V _{dd} =3V, 4 clock instruction, OSCI / OSCO =20pF / 20pF					
		20MHz		1.27			
		16MHz		1.07			
I _{DD}	Operating current	HF mode, V _{dd} =5V, 2 clock instruction, OSCI / OSCO =20pF / 20pF					mA
		20MHz		4.36			
		16MHz		3.41			
		HF mode, V _{dd} =3V, 2 clock instruction, OSCI / OSCO =20pF / 20pF					
		20MHz		1.94			
		16MHz		1.46			
I _{DD}	Operating current	XT mode, V _{dd} =5V, 4 clock instruction, OSCI / OSCO =20pF / 20pF					mA
		20MHz		2.13			
		16MHz		1.77			
		XT mode, V _{dd} =5V, 4 clock instruction, OSCI / OSCO =20pF / 100pF					
		455KHz		0.42			
		32KHz		-			
I _{DD}	Operating current	XT mode, V _{dd} =3V, 4 clock instruction, OSCI / OSCO =20pF / 20pF					mA
		16MHz		0.76			
		8MHz		0.43			
		XT mode, V _{dd} =3V, 4 clock instruction, OSCI / OSCO =20pF / 100pF					
		455KHz		0.16			
		32KHz		0.10			
I _{DD}	Operating current	XT mode, V _{dd} =5V, 2 clock instruction, OSCI / OSCO =20pF / 20pF					mA
		20MHz		3.12			
		16MHz		2.57			

Sym	Description	Conditions	Min.	Typ.	Max.	Unit	
I _{DD}	Operating current	XT mode, V _{DD} =5V, 2 clock instruction, OSCI / OSCO =20pF / 100pF				mA	
		455KHz		0.44			
		32KHz		-			
I _{DD}	Operating current	XT mode, V _{DD} =3V, 2 clock instruction, OSCI / OSCO =20pF / 20pF				mA	
		16MHz		-			
		8MHz		0.62			
I _{DD}	Operating current	XT mode, V _{DD} =3V, 2 clock instruction, OSCI / OSCO =20pF / 100pF				mA	
		455KHz		0.44			
		32KHz		-			
I _{DD}	Operating current	LF mode, V _{DD} =5V, 4 clock instruction, OSCI / OSCO =20pF / 20pF				uA	
		455KHz		106.3			
		32KHz		42.5			
		LF mode, V _{DD} =3V, 4 clock instruction, OSCI / OSCO =20pF / 20pF					
		455KHz		38.7			
		32KHz		12.1			
I _{DD}	Operating current	LF mode, V _{DD} =5V, 2 clock instruction, OSCI / OSCO =20pF / 20pF				uA	
		455KHz		130.9			
		32KHz		44.8			
		LF mode, V _{DD} =3V, 2 clock instruction, OSCI / OSCO =20pF / 20pF					
		455KHz		50.4			
		32KHz		13			
I _{DD}	Operating current	ERC mode, V _{DD} =5V, 4 clock instruction				mA	
		C=3P	R=1Kohm	F=NA			-
			R=3.3Kohm	F=16.4MHz			2.87
			R=10Kohm	F=7.4MHz			1.2
		ERC mode, V _{DD} =3V, 4 clock instruction					
		C=3P	R=1Kohm	F=NA			-
			R=3.3Kohm	F=13.6MHz			1.41
			R=10Kohm	F=7MHz			0.61
		I _{DD}	Operating current	ERC mode, V _{DD} =5V, 2 clock instruction			
C=3P	R=1Kohm			F=NA		-	
	R=3.3Kohm			F=15.1MHz		3.94	
	R=10Kohm			F=7.6MHz		1.87	
ERC mode, V _{DD} =3V, 2 clock instruction							
C=3P	R=1Kohm			F=NA		-	
	R=3.3Kohm			F=13.7MHz		2	
	R=10Kohm			F=6.7MHz		0.87	
I _{DD}	Operating current			ERIC mode, external R, V _{DD} =5V, 4 clock instruction			
		F=8MHz	R=103.2Kohm		1.11		
		F=4MHz	R=206.2Kohm		0.58		
		ERIC mode, external R, V _{DD} =3V, 4 clock instruction					
		F=8MHz	R=99.4Kohm		0.56		
		F=4MHz	R=187.6Kohm		0.29		

Sym	Description	Conditions	Min.	Typ.	Max.	Unit
I _{DD}	Operating current	ERIC mode, external R, V _{dd} =5V, 2 clock instruction				mA
		F=8MHz	R=103.2Kohm		1.78	
		F=4MHz	R=206.2Kohm		0.9	
		ERIC mode, external R, V _{dd} =3V, 2 clock instruction				
		F=8MHz	R=99.4Kohm		0.89	
		F=4MHz	R=187.6Kohm		0.46	
I _{DD}	Operating current	IRC mode, internal R, V _{dd} =5V, 4 clock instruction				mA
		F=8MHz			1.77	
		F=4MHz			0.93	
		F=1MHz			0.32	
		F=455KHz			0.21	
		IRC mode, internal R, V _{dd} =3V, 4 clock instruction				
		F=8MHz			0.97	
		F=4MHz			0.55	
		F=1MHz			0.2	
		F=455KHz			0.14	
I _{DD}	Operating current	IRC mode, internal R, V _{dd} =5V, 2 clock instruction				mA
		F=8MHz			1.75	
		F=4MHz			0.95	
		F=1MHz			0.33	
		F=455KHz			0.22	
		IRC mode, internal R, V _{dd} =3V, 2 clock instruction				
		F=8MHz			0.99	
		F=4MHz			0.55	
		F=1MHz			0.21	
		F=455KHz			0.15	

6.2 ELECTRICAL CHARACTERISTICS Charts of FM8PB53B

6.2.1 Operator Frequency vs. Operator voltage (Ta=25°C)

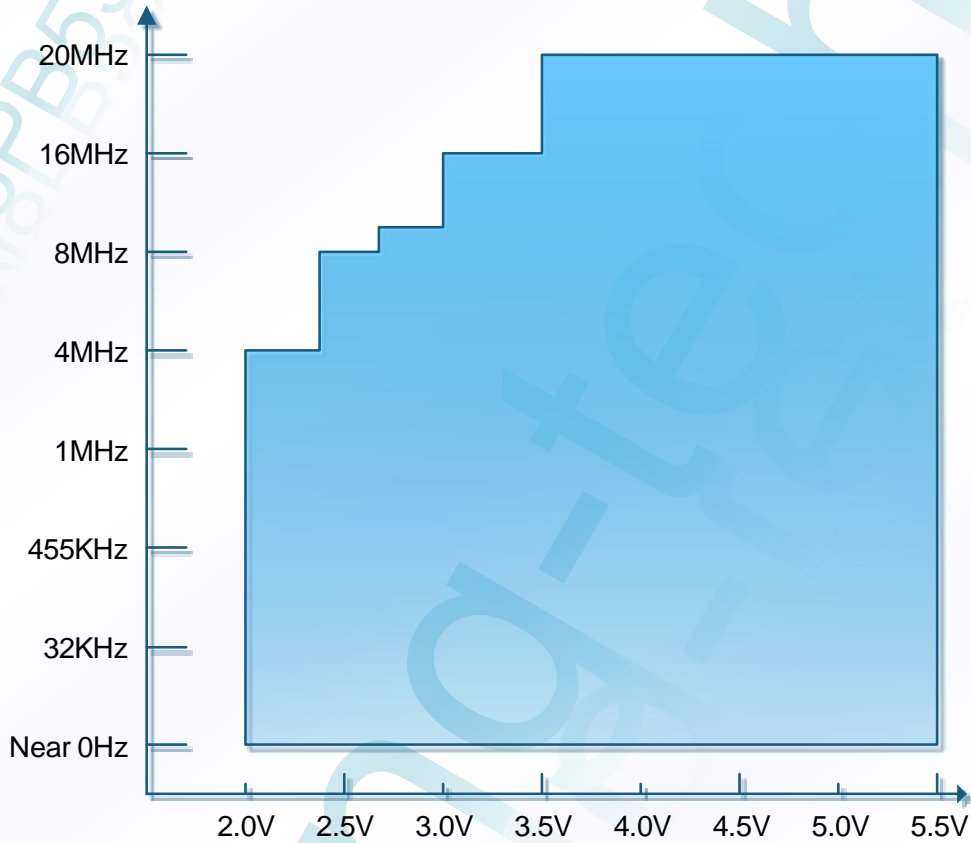

6.2.2 Internal 4 MHz RC vs. Supply Voltage (Ta=25°C)

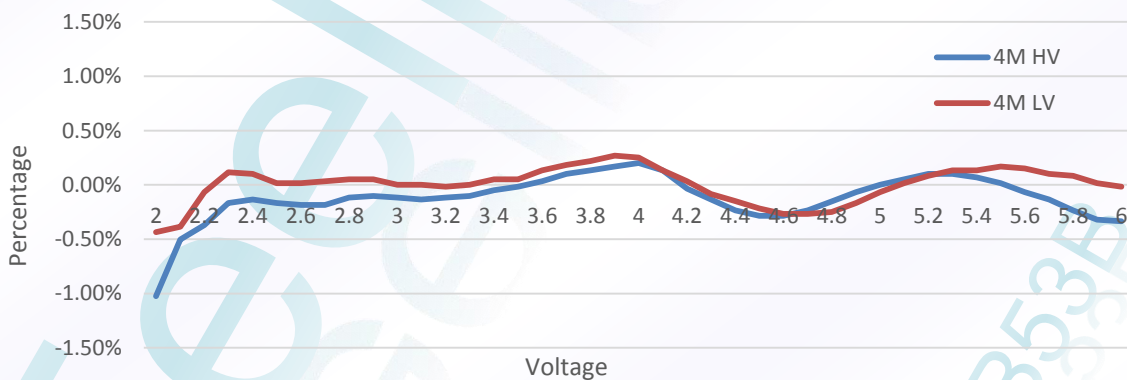

Note: Curves are for design reference only.

6.2.3 Internal 8 MHz RC vs. Supply Voltage (Ta=25°C)

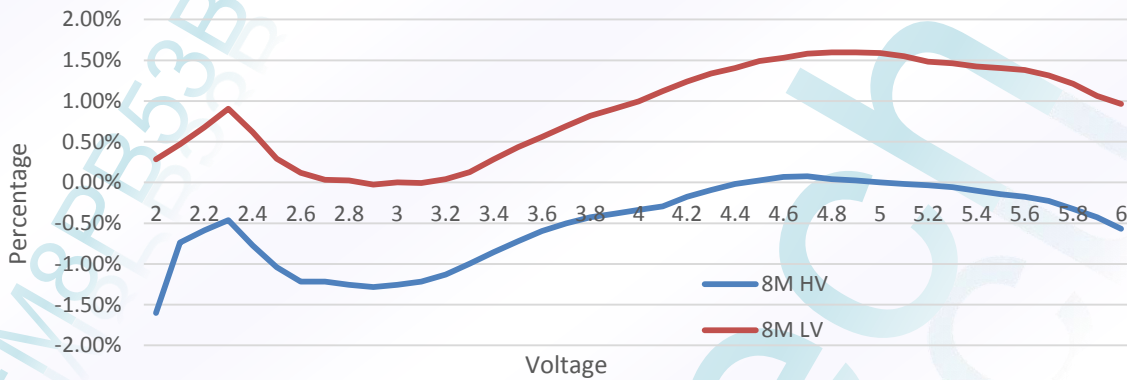

Note: Curves are for design reference only.

6.2.4 Internal 1 MHz RC vs. Supply Voltage (Ta=25°C)

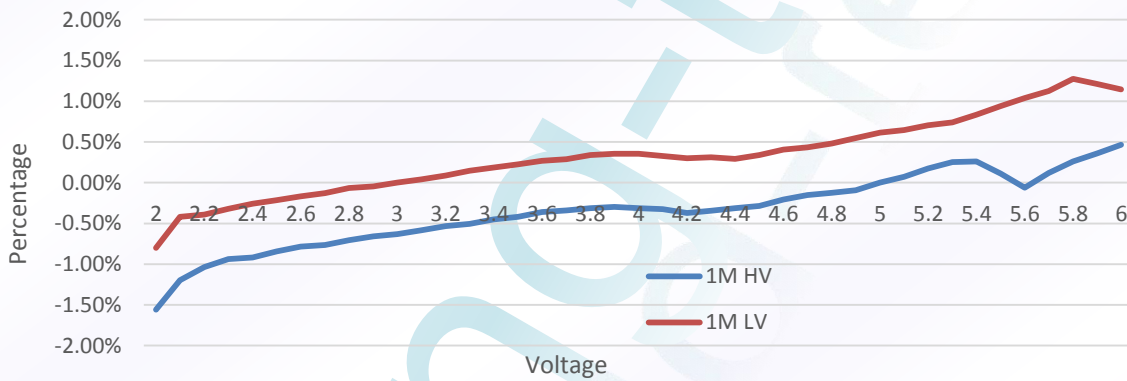

Note: Curves are for design reference only.

6.2.5 Internal 455 KHz RC vs. Supply Voltage (Ta=25°C)

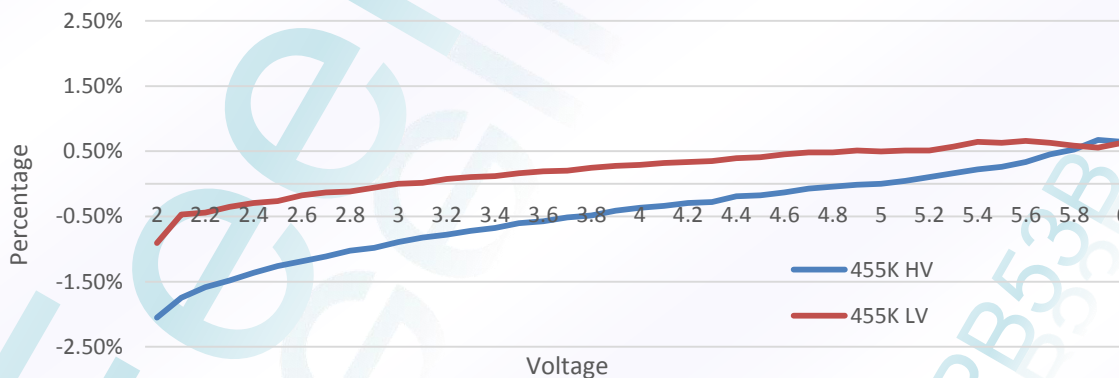

Note: Curves are for design reference only.

6.2.6 Internal 4 MHz RC vs. Temperature

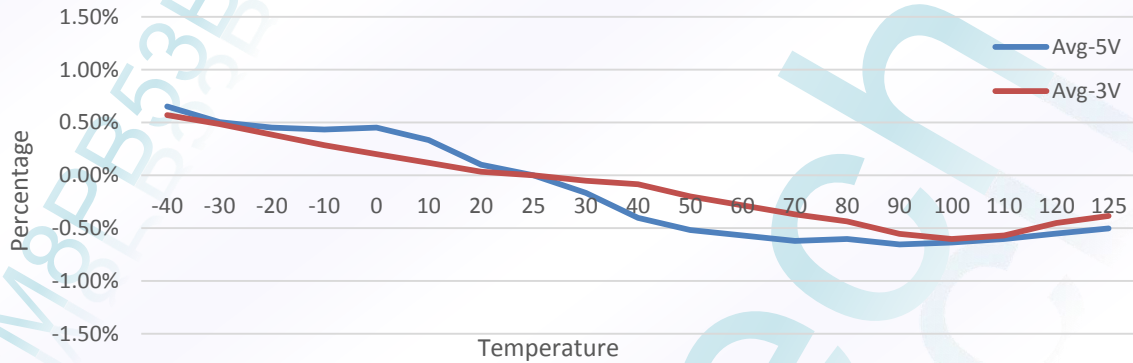

Note: Curves are for design reference only.

6.2.7 Internal 8 MHz RC vs. Temperature

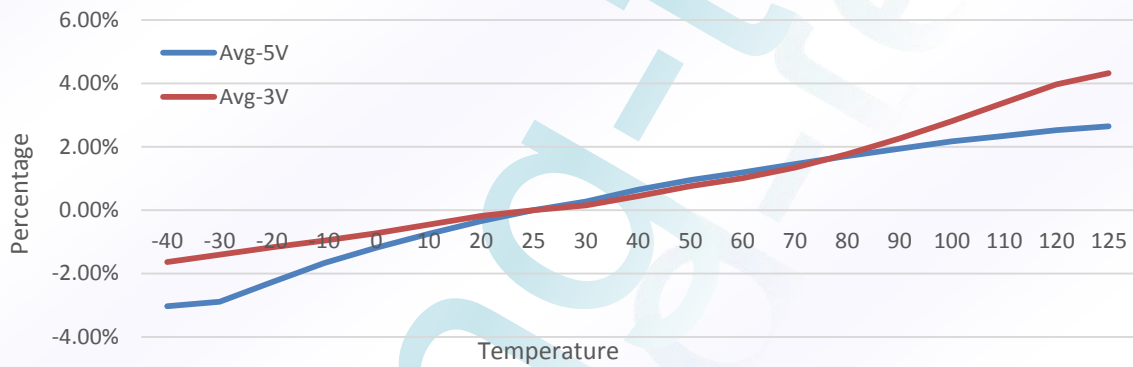

Note: Curves are for design reference only.

6.2.8 Internal 1 MHz RC vs. Temperature

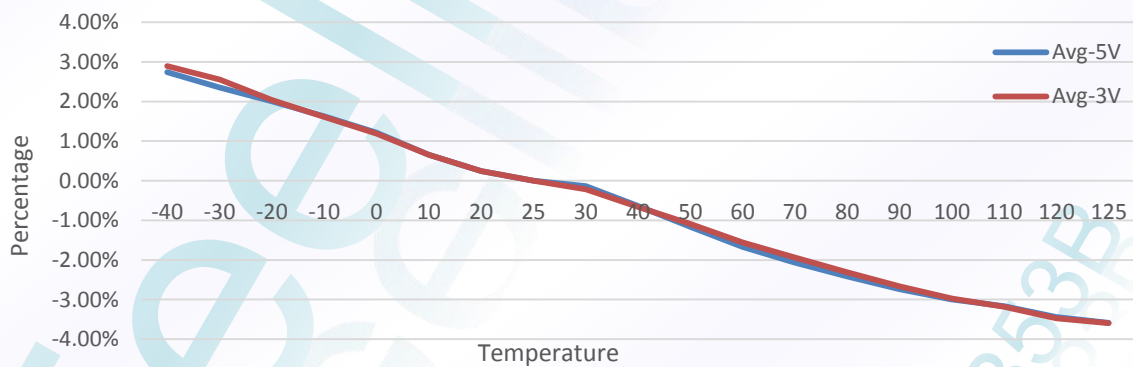

Note: Curves are for design reference only.

6.2.9 Internal 455 KHz RC vs. Temperature

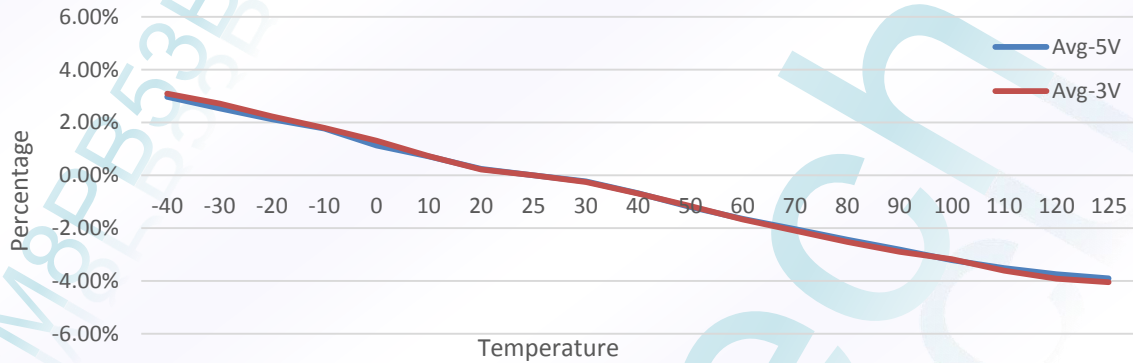

Note: Curves are for design reference only.

6.2.10 WDT 18mS Reset time vs. Temperature

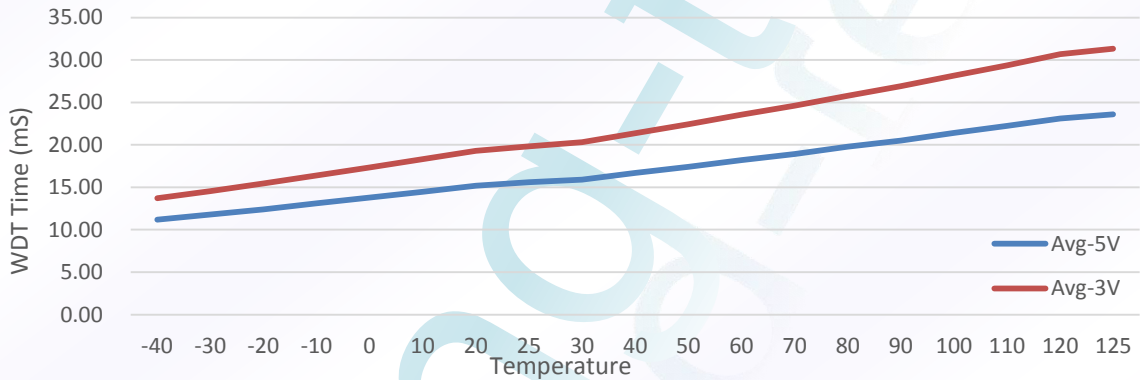

Note: Curves are for design reference only.

6.2.11 WDT 4.5mS Reset time vs. Temperature

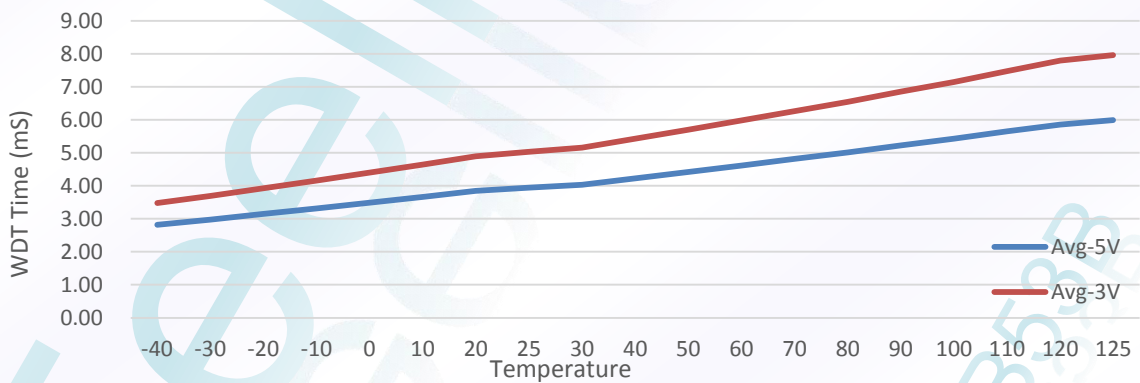

Note: Curves are for design reference only.

6.2.12 WDT 72mS Reset time vs. Temperature

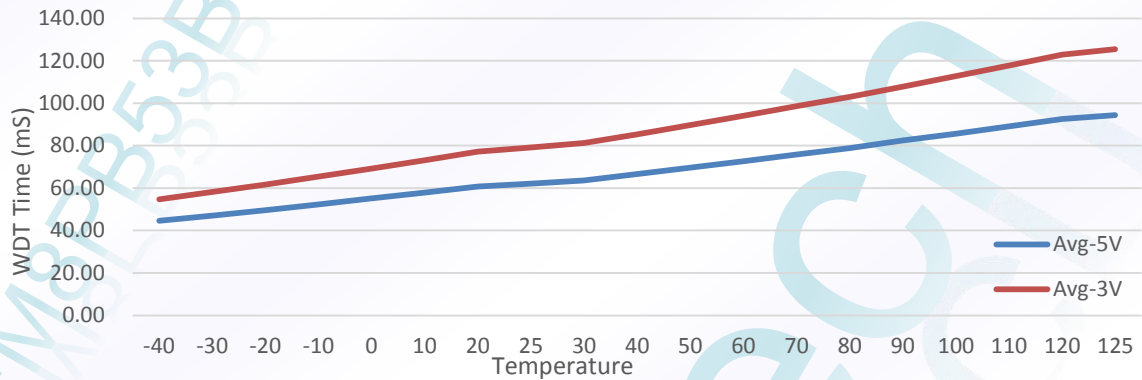

Note: Curves are for design reference only.

6.2.13 WDT 288mS Reset time vs. Temperature

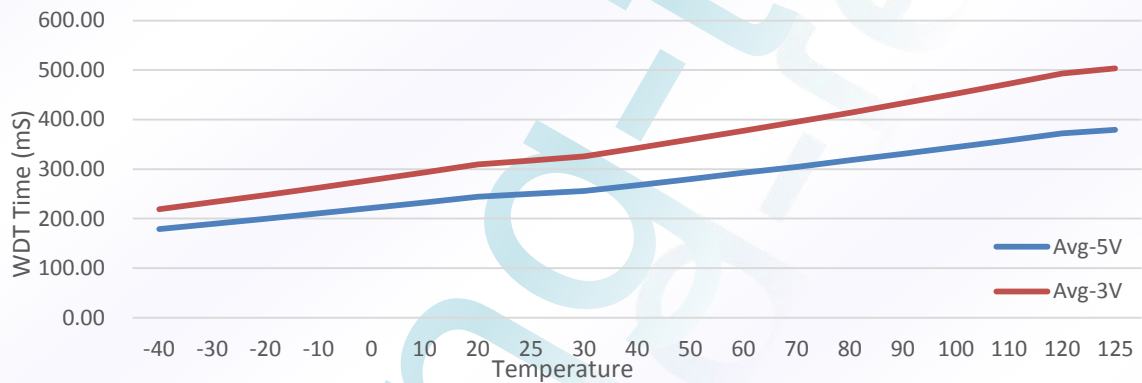

Note: Curves are for design reference only.

6.2.14 WDT 18mS Reset time vs. Supply Voltage (Ta=25°C)

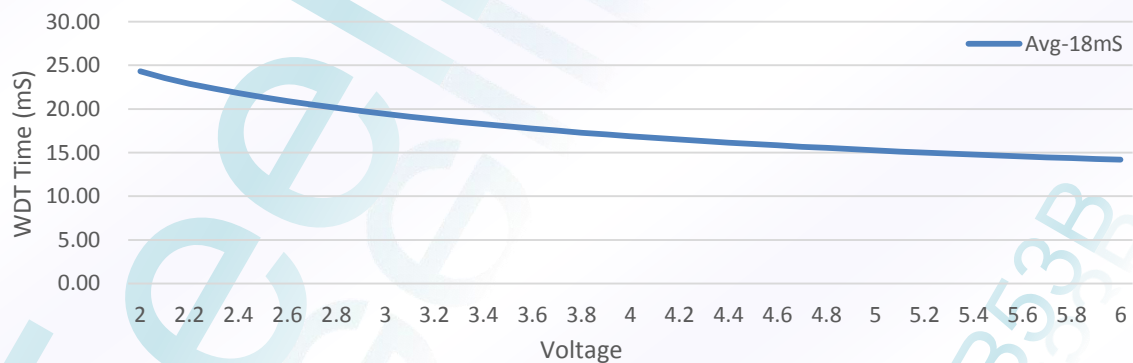

Note: Curves are for design reference only.

6.2.15 WDT 4.5mS Reset time vs. Supply Voltage (Ta=25°C)

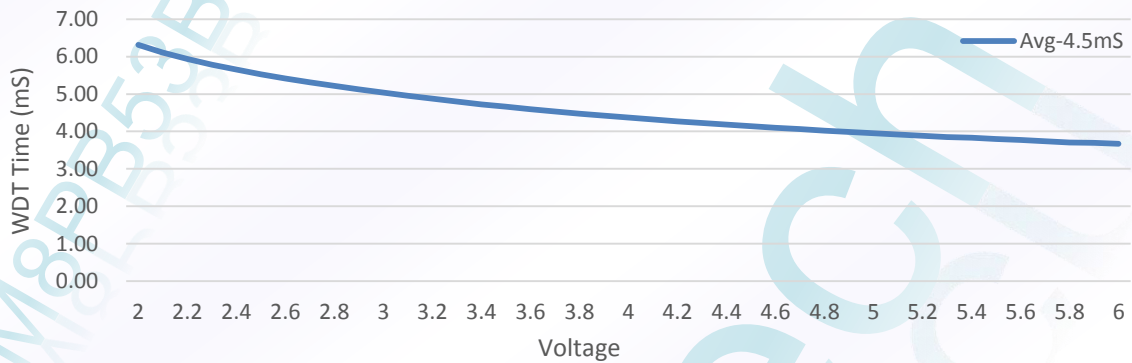

Note: Curves are for design reference only.

6.2.16 WDT 72mS Reset time vs. Supply Voltage (Ta=25°C)

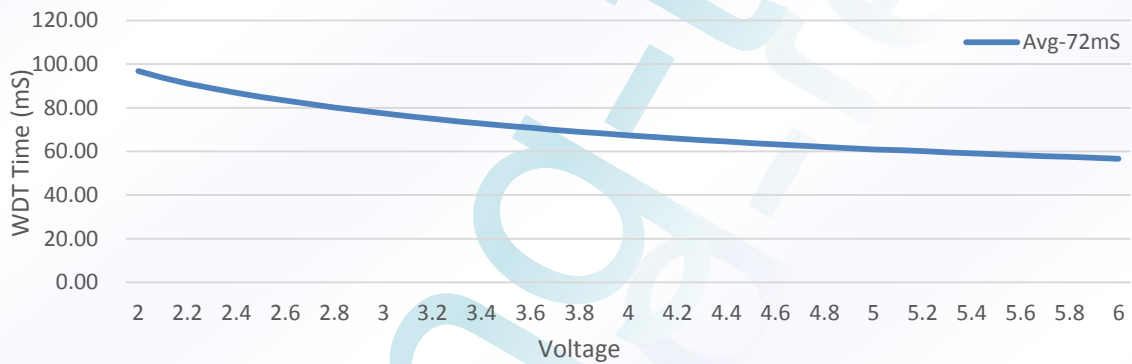

Note: Curves are for design reference only.

6.2.17 WDT 288mS Reset time vs. Supply Voltage (Ta=25°C)

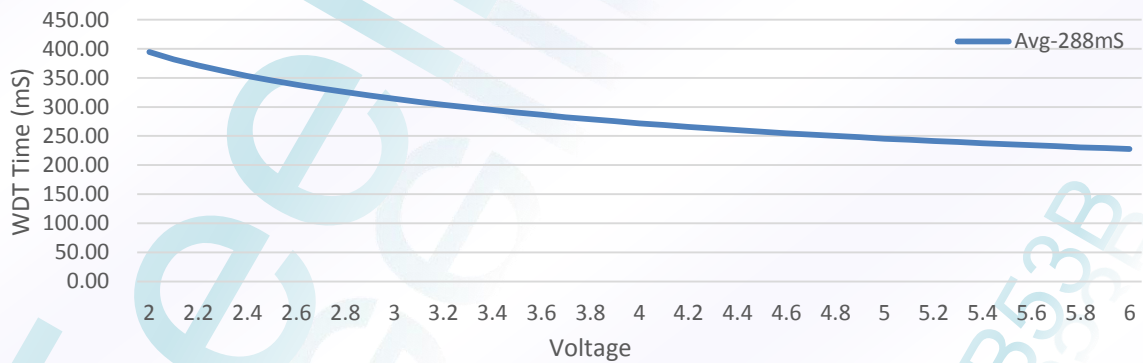

Note: Curves are for design reference only.

6.2.18 LVDT 2.0V vs. Temperature

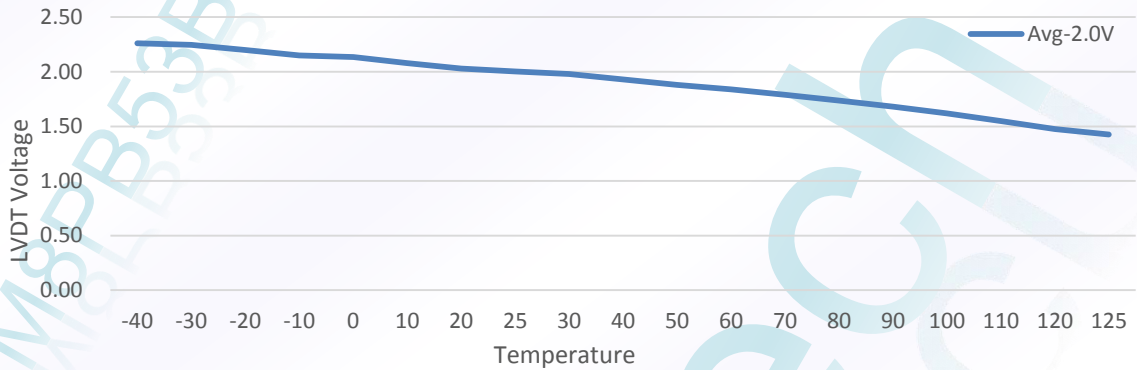

Note: Curves are for design reference only.

6.2.19 LVDT 3.6V vs. Temperature

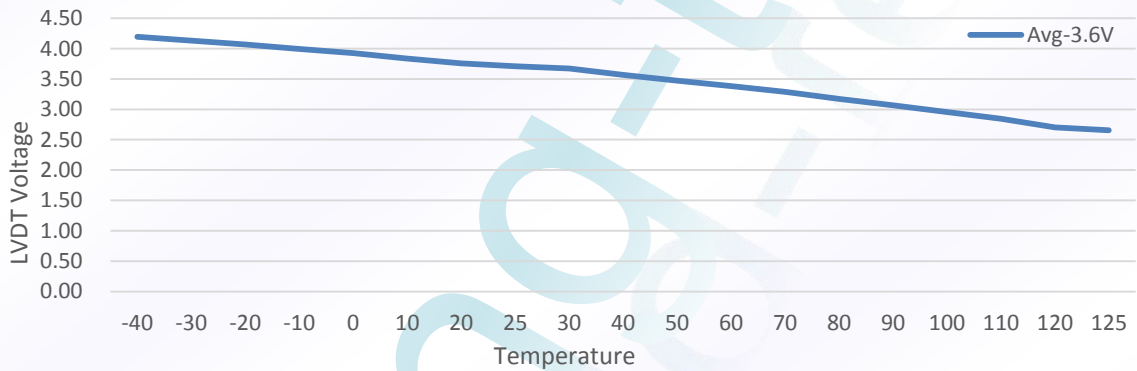

Note: Curves are for design reference only.

6.2.20 LVDT 1.8V vs. Temperature

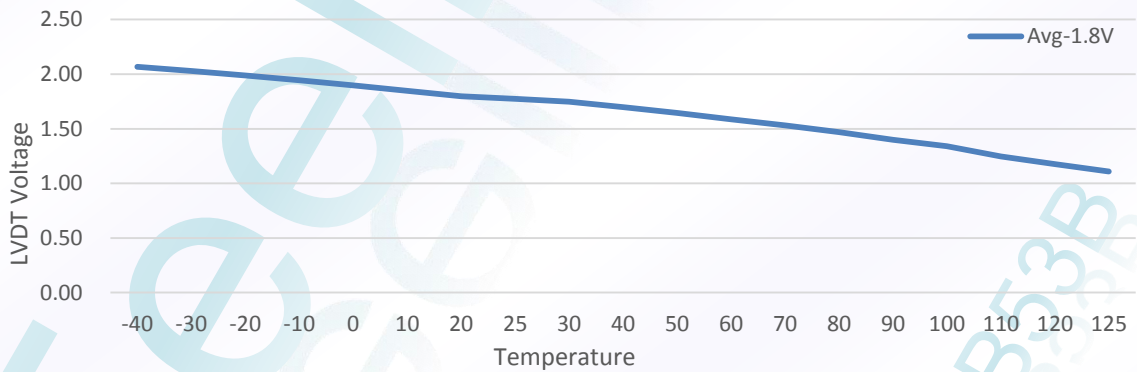

Note: Curves are for design reference only.

6.2.21 LVDT 2.2V vs. Temperature

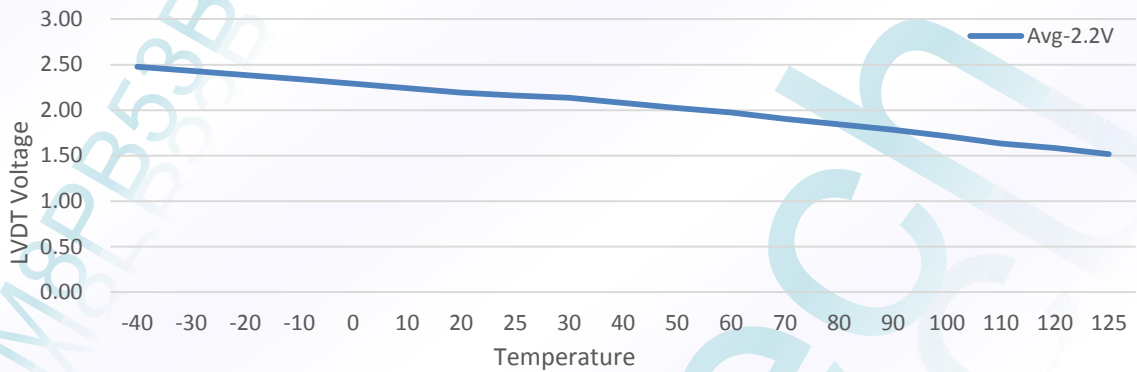

Note: Curves are for design reference only.

6.2.22 LVDT 2.4V vs. Temperature

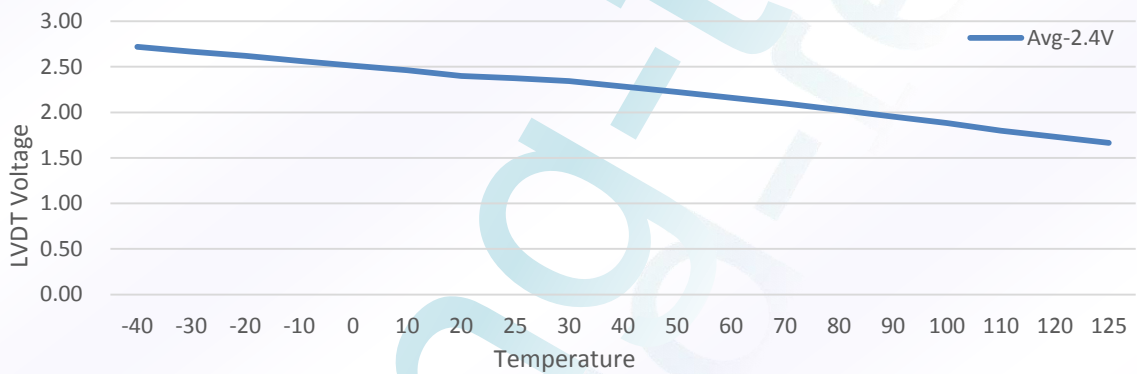

Note: Curves are for design reference only.

6.2.23 LVDT 2.6V vs. Temperature

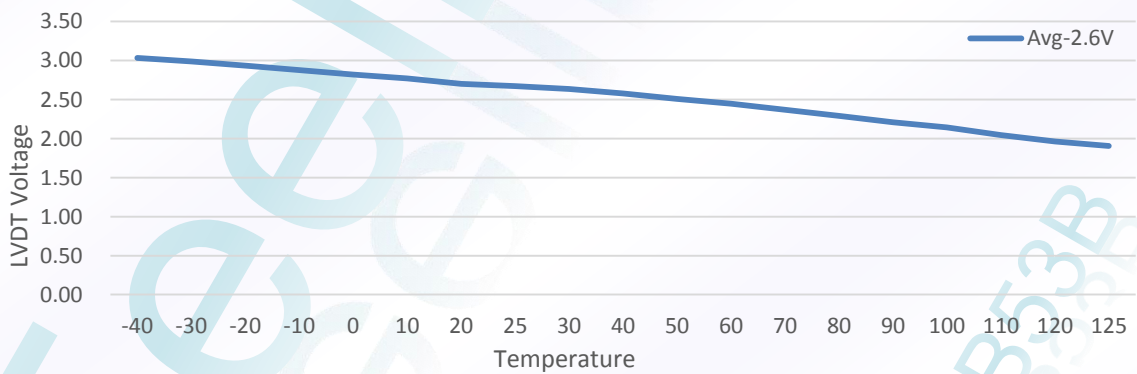

Note: Curves are for design reference only.

7.0 PACKAGE DIMENSION

7.1 14-PIN PDIP 300mil

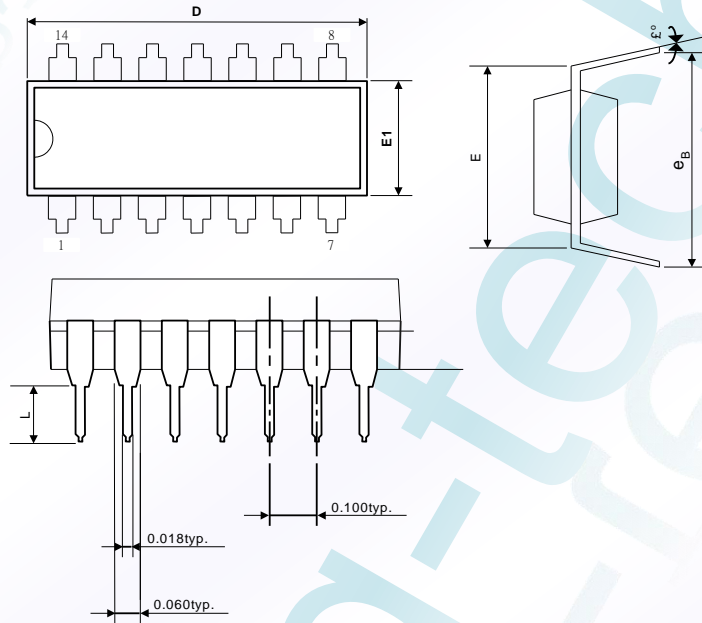

Symbols	Dimension In Inches		
	Min	Nom	Max
A	-	-	0.210
A1	0.015	-	-
A2	0.125	0.130	0.135
D	0.735	0.750	0.775
E	0.300 BSC.		
E1	0.245	0.250	0.255
L	0.115	0.130	0.150
eB	0.335	0.355	0.375
θ°	0°	7°	15°

7.2 14-PIN SOP 150mil

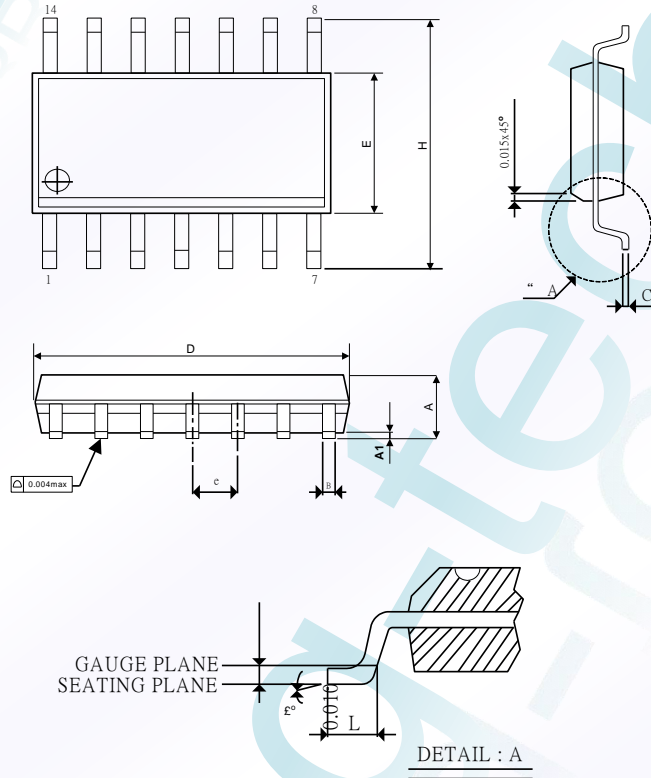

Symbols	Dimension In Inches		
	Min	Nom	Max
A	0.058	0.064	0.068
A1	0.004	-	0.010
B	0.013	0.016	0.020
C	0.0075	0.008	0.0098
D	0.336	0.341	0.344
E	0.150	0.154	0.157
e	-	0.050	-
H	0.228	0.236	0.244
L	0.015	0.025	0.050
θ°	0°	-	8°

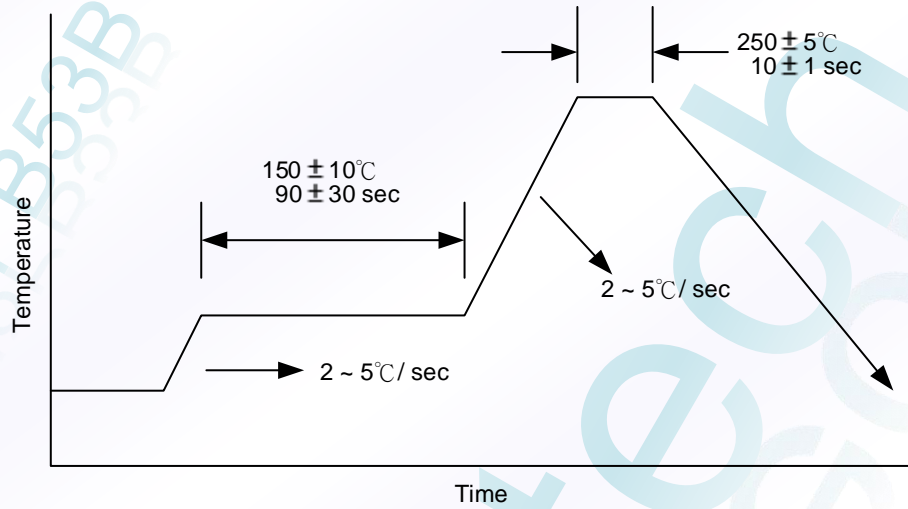
8.0 PACKAGE IR Re-flow Soldering Curve

9.0 ORDERING INFORMATION

OTP Type MCU	Package Type	Pin Count	Package Size
FM8PB53BP	PDIP	14	300 mil
FM8PB53BD	SOP	14	150 mil