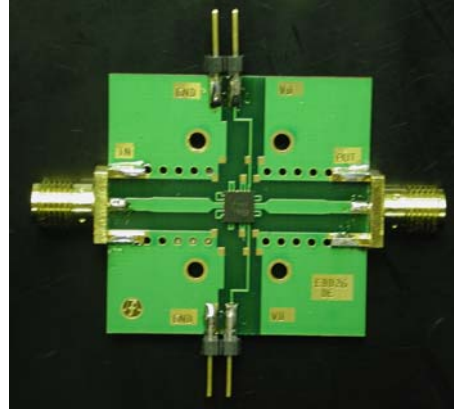

**HIGH LINEARITY INTEGRATED BALANCED AMPLIFIER MODULE**
**FEATURES (1.7-2.0GHz):**

- Balanced low noise amplifier module
- No external couplers required
- Excellent 42 dBm Output IP3
- 28.5 dBm Output Power (P1dB)
- Excellent Return Loss (RL): -25dB
- 14 dB Small-Signal Gain (SSG)
- 1.7 dB Noise Figure
- 6 V supply (380mA current)
- Cost effective footprint: 4mm x 4mm QFN
- 6 mm x 6mm evaluation board available
- RoHS compliant: (Directive 2002/95/EC)

**GENERAL DESCRIPTION:**

The BA2250QFN MMIC module is a self-biased, integrated and packaged balanced amplifier mounted onto 6x6mm<sup>2</sup> FR4 board. The active device is a pair of pseudomorphic High Electron Mobility Transistors (pHEMT) specifically optimised for balanced configuration systems. The Filtronic 0.25µm process ensures class-leading noise performance. The use of a small footprint plastic package allows for a cost effective total system implementation.

**BOARD PHOTOGRAPH:**

**TYPICAL APPLICATIONS:**

- Wireless infrastructure: Tower mounted Amplifiers and front end LNAs for EGSM/PCS/WCDMA/UMTS base stations
- High intercept-point LNAs

**ELECTRICAL SPECIFICATIONS:**

PARAMETER	SYMBOL	CONDITIONS	MIN	TYP	MAX	UNITS
Frequency	Freq	VDS = 6.0 V; IDS = 380mA	1.7	1.85	2	GHz
Minimum Noise Figure	NF	VDS = 6.0 V; IDS = 380mA	1.75	1.8	2.1	dB
Input Third-Order Intercept Point	IIP3	VDS = 6.0 V; IDS = 380mA	27.5	28.5	30	dBm
Small-Signal Gain	SSG	VDS = 6.0 V; IDS = 380mA	13	14	14.3	dB
Small-Signal Input Return Loss	S11	VDS = 6.0 V; IDS = 380mA	-30	-25	-20	dB
Small-Signal Output Return Loss	S22	VDS = 6.0 V; IDS = 380mA	-40	-30	-25	dB
Power at 1dB Gain Compression	P1dB	VDS = 6.0 V; IDS = 380mA	28	28.5	29	dBm

Note: T<sub>AMBIENT</sub> = 22°C

**ABSOLUTE MAXIMUM RATING<sup>1</sup>:**

PARAMETER	SYMBOL	TEST CONDITIONS	ABSOLUTE MAXIMUM
Drain-Source Voltage	VDS	6	9V
Channel Operating Temperature	TCH	Under any acceptable bias state	175°C
Storage Temperature	TSTG	Non-Operating Storage	-55°C to 150°C

**Notes:**

1.  $T_{\text{Ambient}} = 22^{\circ}\text{C}$  unless otherwise noted; exceeding any one of these absolute maximum ratings may cause permanent damage to the device
2. Information on the mounting of QFN style packages for optimum thermal performance is available on request.

**BIASING GUIDELINE:**

- The BA2250QFN module is a self-biased circuit, which employ an RF-bypassed source resistor to provide the negative Gate-Source bias voltage, and such circuits provide some temperature stabilization for the device

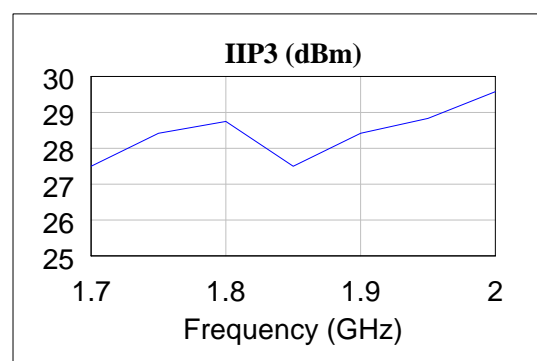
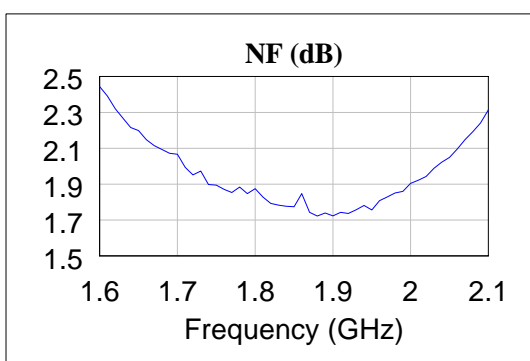
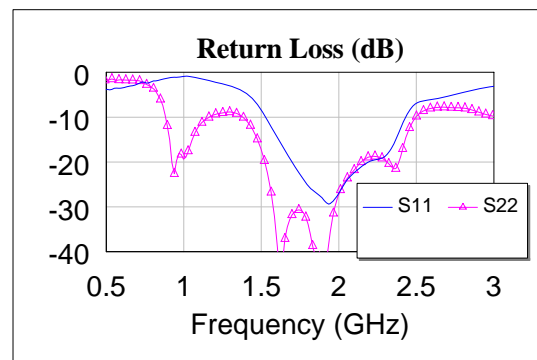
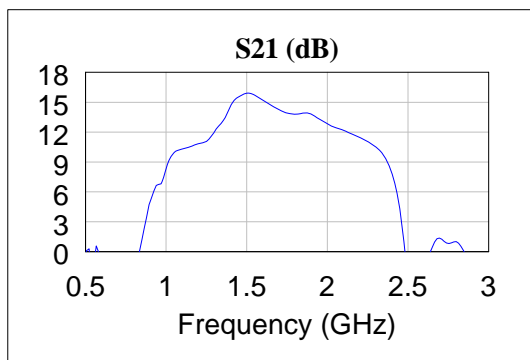
**TYPICAL MEASURED PERFORMANCE ON EVALUATION BOARD:**

Note: NF can be centred by optimising printed inductive elements

**REFERENCE DESIGN (1.7-2GHz):**

COMPONENT	(1.7-2)GHZ
C1,C2	1pF (0603)
QFN	4x4 QFN package
Eval board material	6x6 mm RF4 Board (0.8 mm thick 1/2 Ounce Cu on both sides and printed inductors)

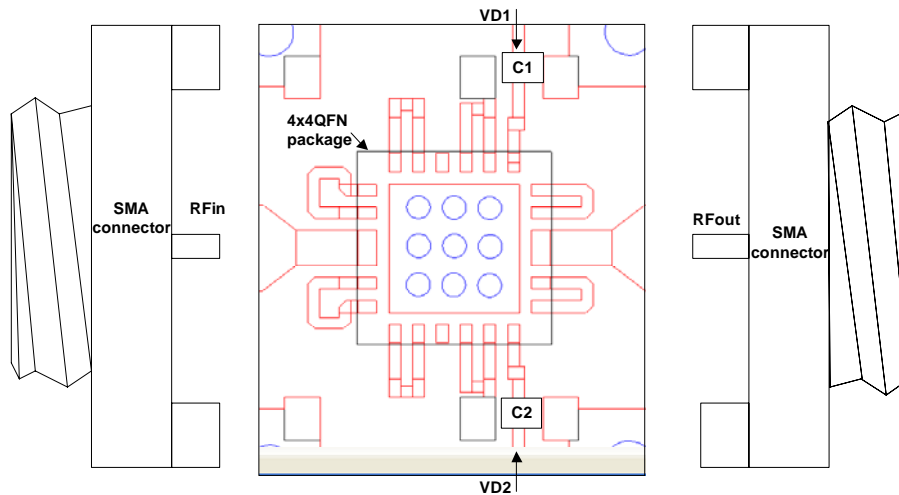
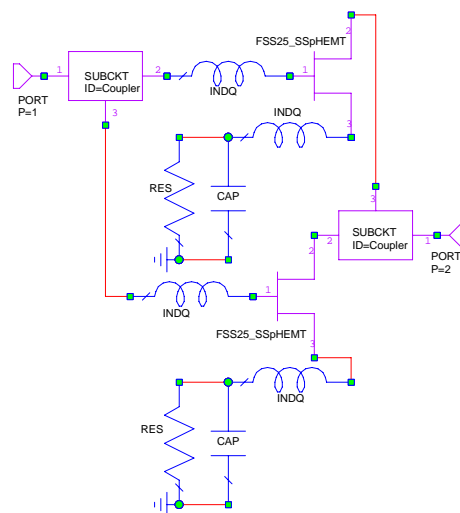
**EVALUATION BOARD LAYOUT (DRAWINGS AVAILABLE ON REQUEST):**

**SIMPLIFIED MODULE SCHEMATIC:**

**PACKAGE OUTLINE:**

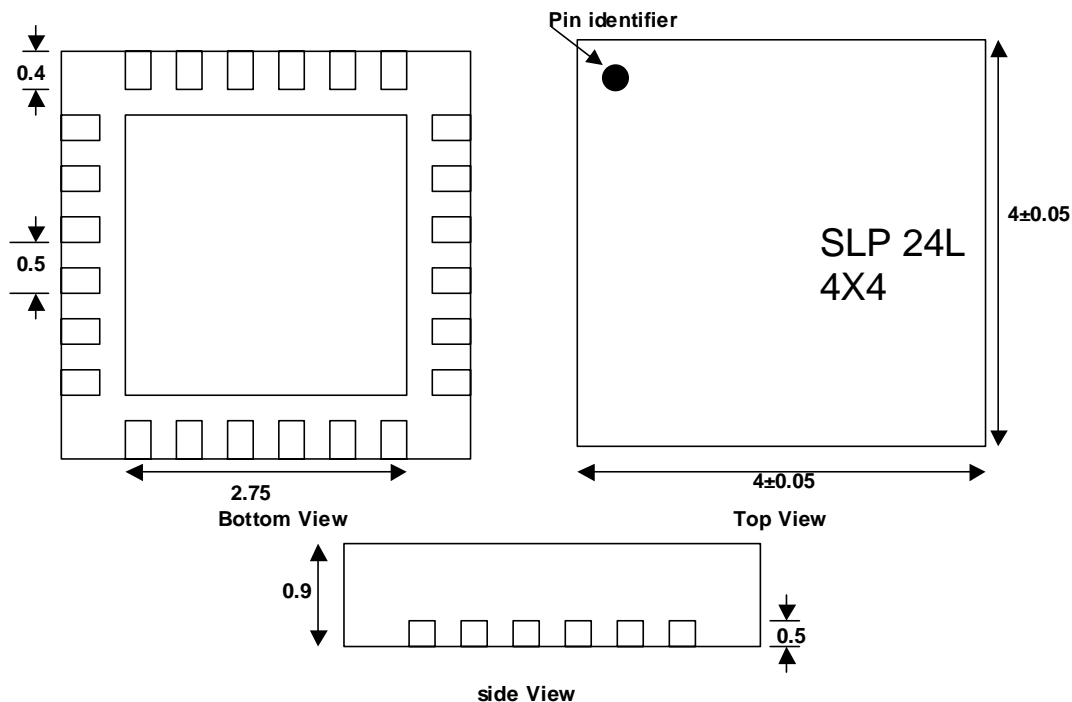
(Dimensions in millimetres – mm)

**PREFERRED ASSEMBLY INSTRUCTIONS:**

Please contact Filtronic Compound Semiconductors Ltd for further details.

**HANDLING PRECAUTIONS:**

To avoid damage to the devices care should be exercised during handling. Proper Electrostatic Discharge (ESD) precautions should be observed at all stages of storage, handling, assembly, and testing. These devices should be treated as Class 1A (0-500 V) as defined in JEDEC Standard No. 22-A114. Further information on ESD control measures can be found in MIL-STD-1686 and MIL-HDBK-263.

**APPLICATION NOTES & DESIGN DATA:**

Application Notes and design data including S-parameters are available; please contact Filtronic Compound Semiconductors Ltd.

**DISCLAIMERS:**

This product is not designed for use in any space based or life sustaining/supporting equipment.

**ORDERING INFORMATION:**

PART NUMBER	DESCRIPTION
FMA3019QFN-EB	Packaged Balanced MMIC LNA Evaluation Board