

FMS2345A

List

List..... 1

Package outline..... 2

Features..... 2

Mechanical data..... 2

Maximum ratings 2

Electrical characteristics..... 3

Rating and characteristic curves..... 4~ 5

Pinning information..... 6

Marking..... 6

Suggested solder pad layout..... 6

Packing information..... 7

Reel packing..... 8

Suggested thermal profiles for soldering processes..... 8

FMS2345A

30V P-Channel Enhancement Mode MOSFET

Features

- $R_{DS(ON)} \leq 68m\Omega @ V_{GS} = -10V$
- $R_{DS(ON)} \leq 80m\Omega @ V_{GS} = -4.5V$
- $R_{DS(ON)} \leq 100m\Omega @ V_{GS} = -2.5V$
- Super high density cell design for extremely low $R_{DS(ON)}$
- Exceptional on-resistance and maximum DC current capability
- Lead-free parts meet RoHS requirements
- Suffix "-H" indicates Halogen-free part, ex. FMS2345A-H

Applications

- Power management in note book
- Portable equipment
- Battery powered system
- Load switch
- DSC

Mechanical data

- Epoxy: UL94-V0 rated flame retardant
- Case : Molded plastic, SOT-23
- Terminals : Solder plated, solderable per MIL-STD-750, Method 2026
- Mounting Position : Any
- Weight : Approximated 0.008 gram

Maximum ratings (AT $T_A = 25^\circ C$ unless otherwise noted)

PARAMETER	Symbol	Maximum ratings	UNIT
Drain-source voltage	V_{DS}	-30	V
Drain current-continuous $T_A = 25^\circ C$	I_D	-3.6	A
$T_A = 70^\circ C$		-2.9	A
-pulsed	I_{DM}	-14	A
Gate- source voltage	V_{GS}	± 12	V
Maximum power dissipation $T_A = 25^\circ C$	P_D	1.40	W
$T_A = 70^\circ C$		1.00	W
Thermal resistance-junction to ambient*	$R_{\theta JA}$	90	$^\circ C/W$
Operation junction temperature range	T_J	-55 to +150	$^\circ C$
Storage temperature range	T_{STG}	-55 to +150	$^\circ C$

*The device mounted on 1in² FR4 board with 2 oz copper

Package outline

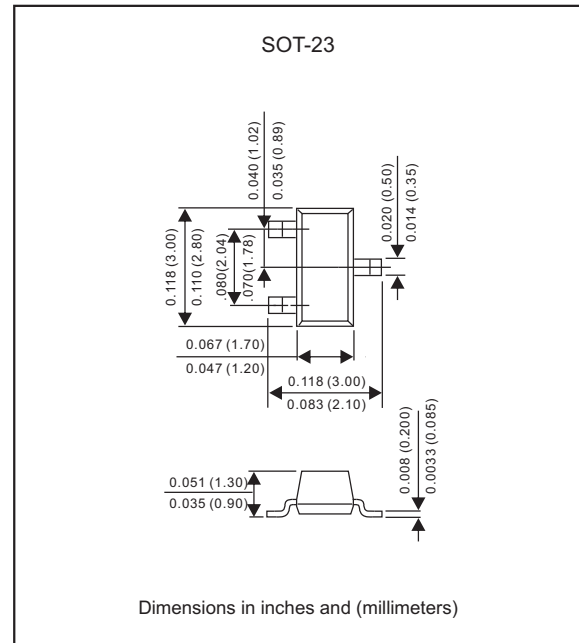

FMS2345A

Electrical characteristics (At $T_A=25^\circ\text{C}$ unless otherwise noted)

PARAMETER	CONDITIONS	Symbol	MIN.	TYP.	MAX.	UNIT
STATIC						
Drain-source breakdown voltage	$V_{GS} = 0V, I_D = -250\mu A$	B_{VDS}	-30			V
Zero gate voltage drain current	$V_{DS} = -24V, V_{GS} = 0V$	I_{DSS}			-1.0	μA
Gate leakage current	$V_{GS} = \pm 12V, V_{DS} = 0$	I_{GSS}			± 100	nA
Gate threshold voltage	$V_{DS} = V_{GS}, I_D = -250\mu A$	$V_{GS(th)}$	-0.6		-1.3	V
Drain-source on-resistance	$V_{GS} = -10V, I_D = -4.2A$ $V_{GS} = -4.5V, I_D = -4.0A$ $V_{GS} = -2.5V, I_D = -2.0A$	$R_{DS(ON)}$		57 62 80	68 80 100	$m\Omega$
Diode forward voltage	$V_{GS} = 0V, I_S = -1.0A$	V_{SD}		-0.7	-1.0	V

DYNAMIC

Input capacitance	$V_{DS} = -15V, V_{GS} = 0V,$ $f = 1.0MHz$	C_{iss}		710		pF
Output capacitance		C_{oss}		70		
Reverse transfer capacitance		C_{rss}		20		
Total gate charge	$V_{DS} = -15V, I_D = -4.0A$ $V_{GS} = -4.5V$	Q_g		9.0		nC
Gate-source charge		Q_{gs}		2.3		
Gate-drain charge		Q_{gd}		2.0		
Turn-on delay time	$V_{DS} = -15V, R_L = 3.6\Omega, R_{GEN} = 6\Omega$ $V_{GS} = -10V$	$t_{d(on)}$		37		ns
Turn-on rise time		t_r		23		
Turn-off delay time		$t_{d(off)}$		46		
Turn-off fall time		t_f		3		

*Pulse test: pulse width $\leq 300\mu s$, duty cycle $\leq 2\%$, Guaranteed by design, not subject to production testing.

Rating and characteristic curves (FMS2345A)

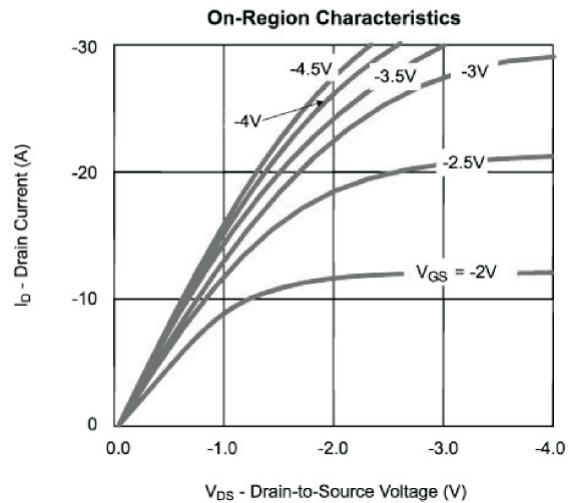
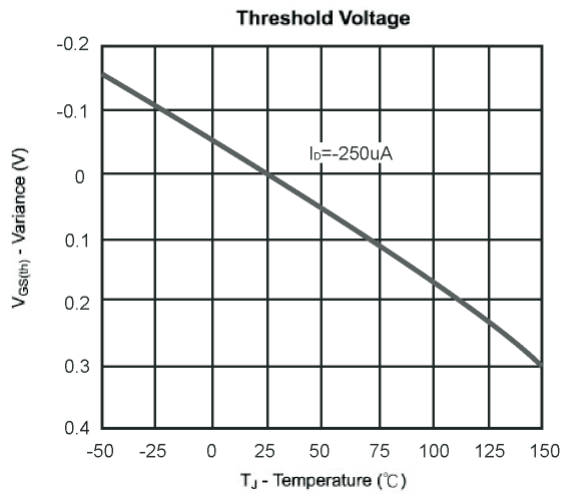
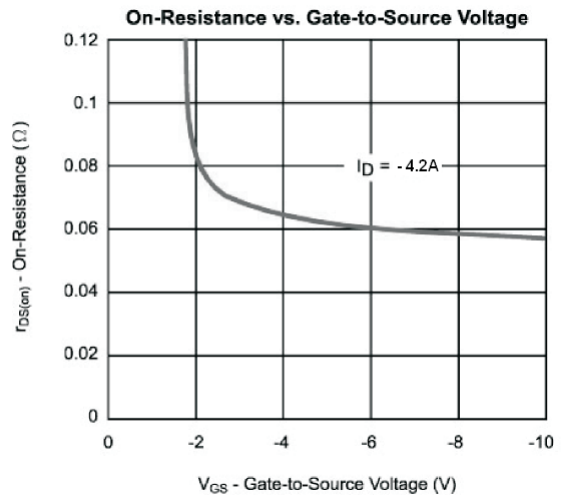
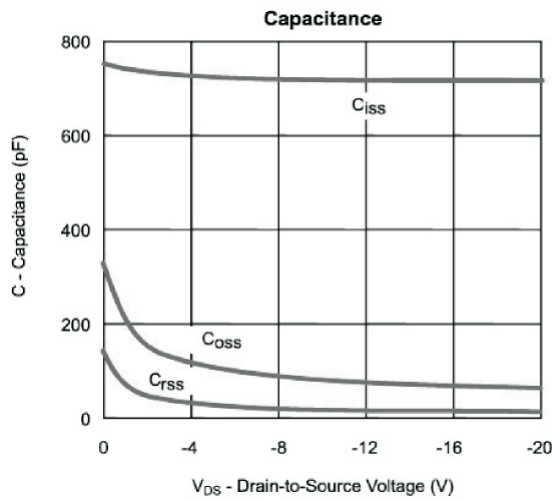
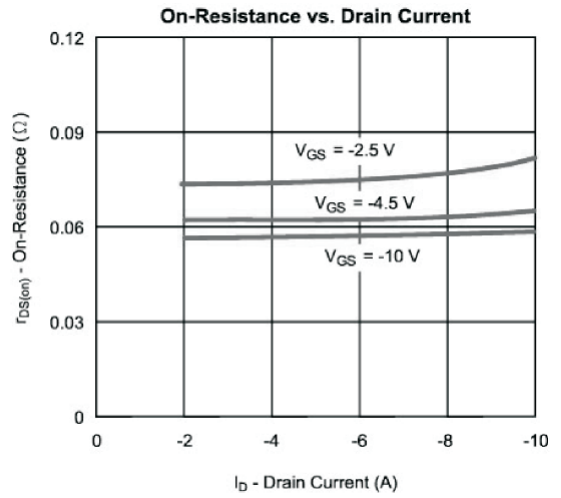
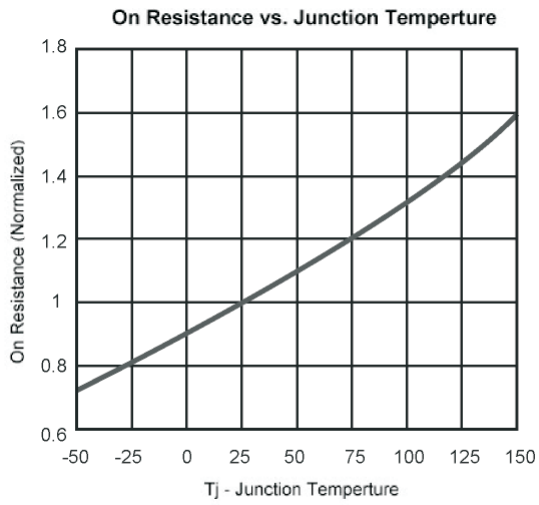

Rating and characteristic curves (FMS2345A)

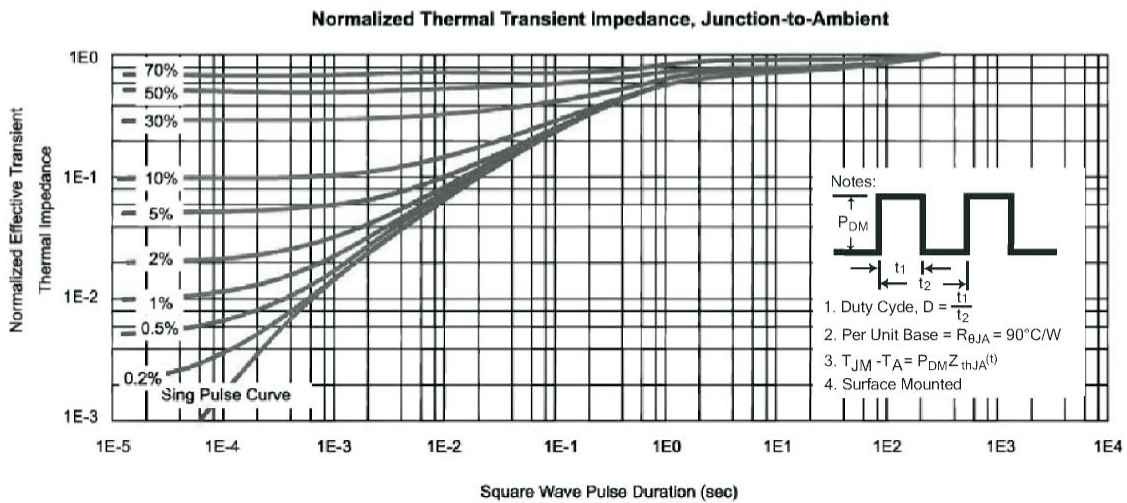
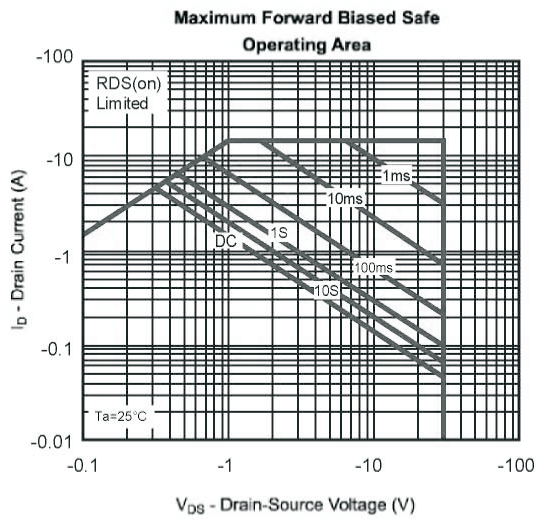
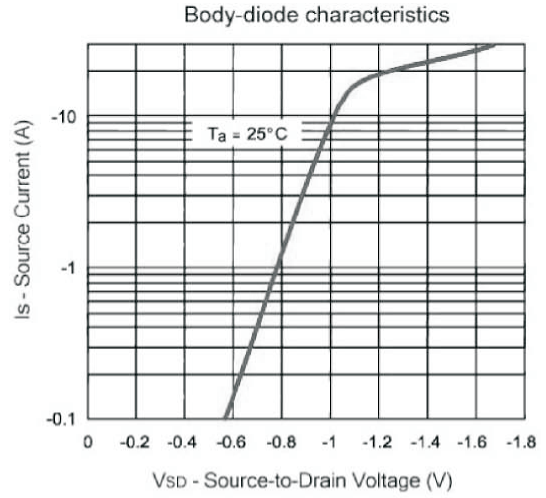
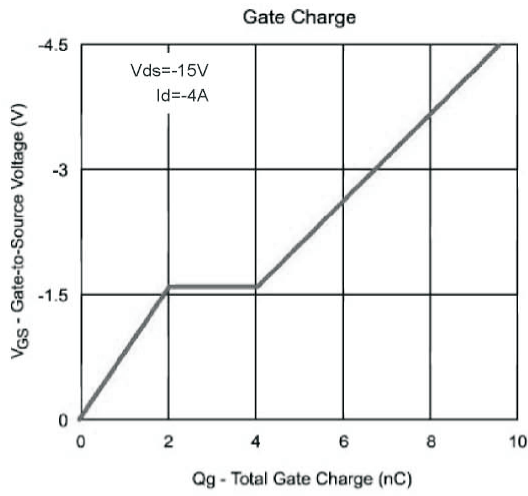

FMS2345A

Pinning information

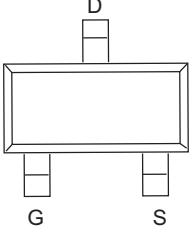
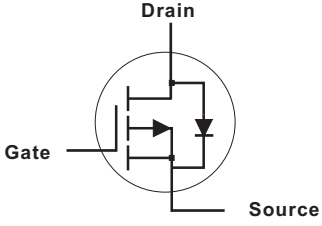
Pin	Simplified outline	Symbol
PinD Drain PinG Gate PinS Source		

Marking

Type number	Marking code
FMS2345A	WSAXX (Note 1)

Note 1:
 "WSA" shown on the 1st~3rd position on --- Marking code
 D/C :
 XX is the sequence of "0-9" & "A~Z"
 0~9 shown on the 4th position on ---2010~2019
 A~Z shown on the 5th position on ---1week~26week
 A~Z shown on the 5th position on ---27week~52week

Suggested solder pad layout

SOT-23

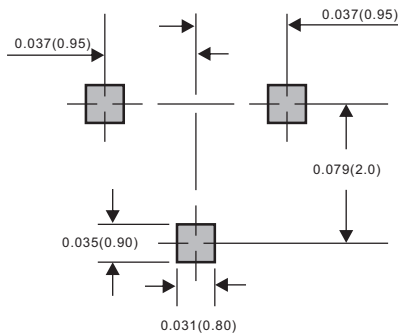

Dimensions in inches and (millimeters)

FMS2345A

Packing information

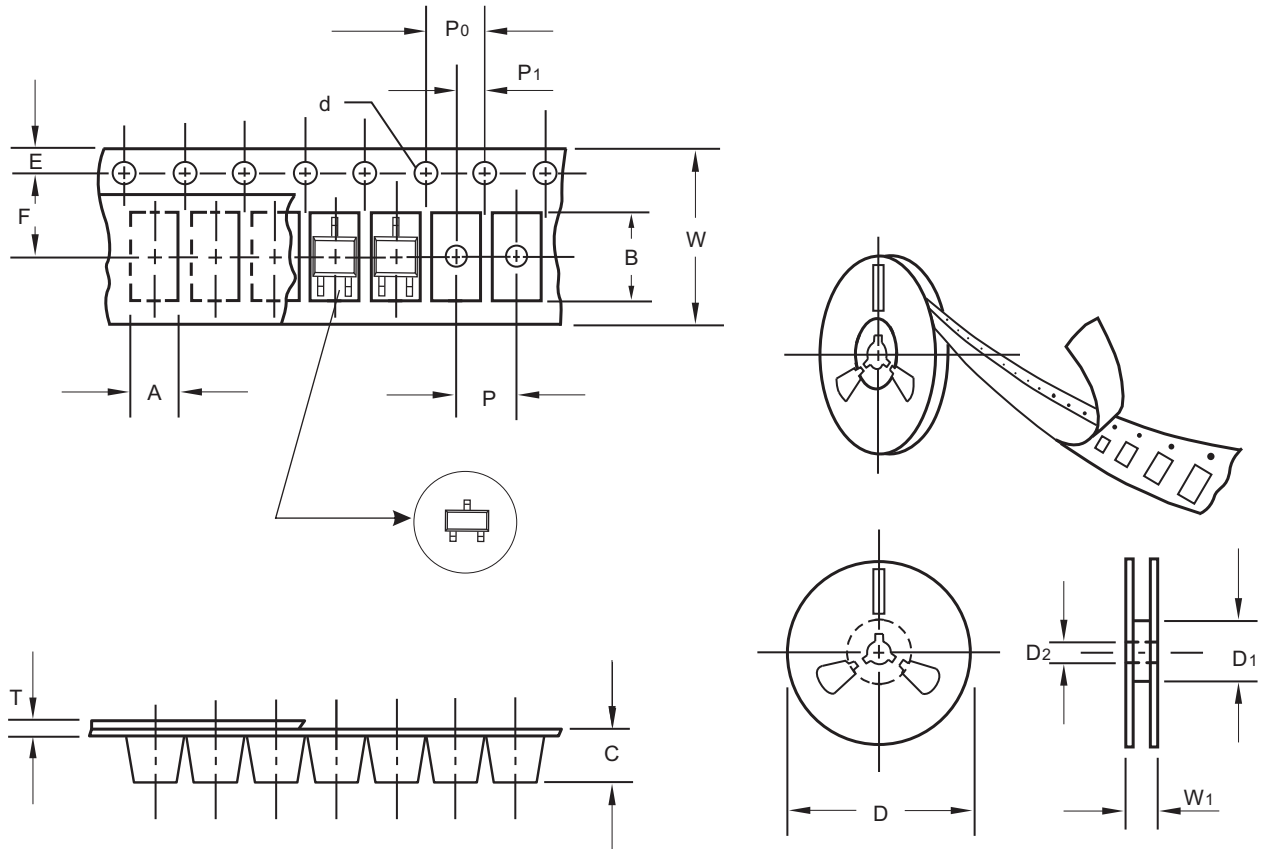

unit:mm

Item	Symbol	Tolerance	SOT-23
Carrier width	A	0.1	3.25
Carrier length	B	0.1	3.15
Carrier depth	C	0.1	1.55
Sprocket hole	d	0.1	1.50
13" Reel outside diameter	D	2.0	-
13" Reel inner diameter	D1	min	-
7" Reel outside diameter	D	2.0	178.00
7" Reel inner diameter	D1	min	55.00
Feed hole diameter	D2	0.5	13.00
Sprocket hole position	E	0.1	1.75
Punch hole position	F	0.1	3.50
Punch hole pitch	P	0.1	4.00
Sprocket hole pitch	P0	0.1	4.00
Embossment center	P1	0.1	2.00
Overall tape thickness	T	0.05	0.25
Tape width	W	0.3	8.00
Reel width	W1	1.0	12.0

Note: Devices are packed in accordance with EIA standard RS-481-A and specifications listed above.

FMS2345A

Reel packing

PACKAGE	REEL SIZE	REEL (pcs)	COMPONENT SPACING (m/m)	BOX (pcs)	INNER BOX (m/m)	REEL DIA, (m/m)	CARTON SIZE (m/m)	CARTON (pcs)	APPROX. GROSS WEIGHT (kg)
SOT-23	7"	3,000	4.0	30,000	183*123*183	178	382*257*387	240,000	11.6

Suggested thermal profiles for soldering processes

- 1.Storage environment: Temperature=5°C~40°C Humidity=55%±25%
- 2.Reflow soldering of surface-mount devices

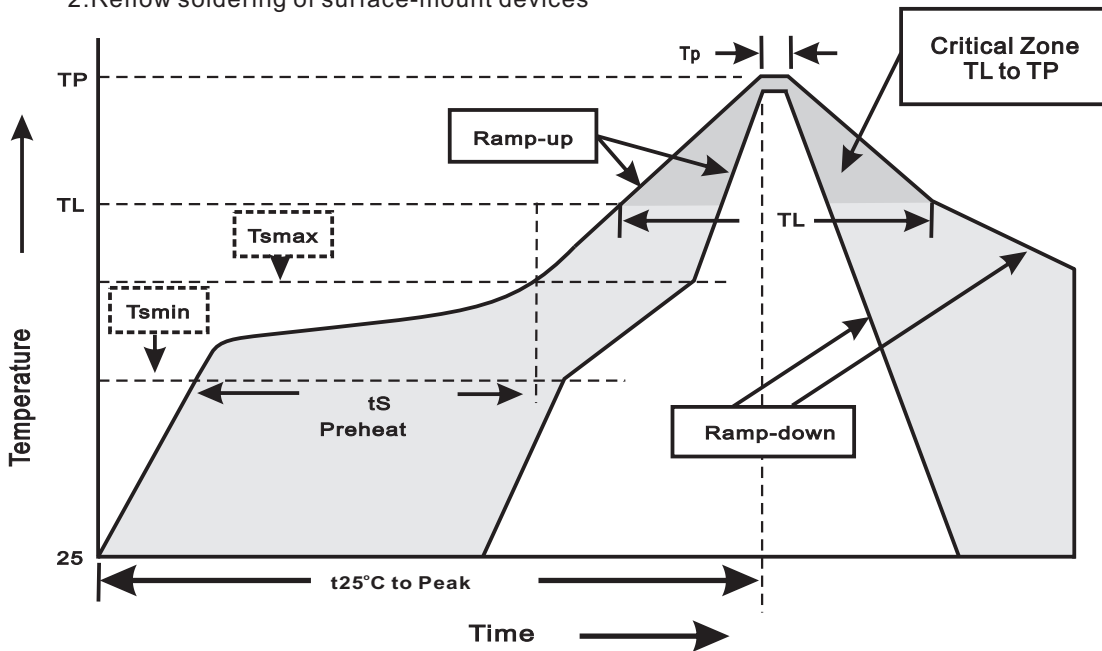

3.Reflow soldering

Profile Feature	Soldering Condition
Average ramp-up rate(T _L to T _P)	<3°C/sec
Preheat -Temperature Min(T _{smin}) -Temperature Max(T _{smax}) -Time(min to max)(t _s)	150°C 200°C 60~120sec
T _{smax} to T _L -Ramp-upRate	<3°C/sec
Time maintained above: -Temperature(T _L) -Time(t _L)	217°C 60~260sec
Peak Temperature(T _P)	255°C-0/+5°C
Time within 5°C of actual Peak Temperature(t _p)	10~30sec
Ramp-down Rate	<6°C/sec
Time 25°C to Peak Temperature	<6minutes