

FMS6502

8-Input, 6-Output Video Switch Matrix with Output Drivers, Input Clamp, and Bias Circuitry

Features

- 8 x 6 Crosspoint Switch Matrix
- Supports SD, PS, and HD 1080i / 1080p Video
- Input Clamp and Bias Circuitry
- Doubly Terminated 75Ω Cable Drivers
- Programmable 0dB or 6dB Gain
- AC- or DC-Coupled Inputs
- AC- or DC-Coupled Outputs
- One-to-One or One-to-Many Input-to-Output Switching
- I²C™-Compatible Digital Interface, Standard Mode
- 3.3V or 5V Single Supply Operation
- Pb-Free TSSOP-24 Package

Applications

- Cable and Satellite Set-Top Boxes
- TV and HDTV Sets
- A / V Switchers
- Personal Video Recorders (PVR)
- Security and Surveillance
- Video Distribution
- Automotive (In-Cabin Entertainment)

Description

The FMS6502 provides eight inputs that can be routed to any of six outputs. Each input can be routed to one or more outputs, but only one input may be routed to any output.

Each input supports an integrated clamp option to set the output sync tip level of video with sync to ~300mV. Alternatively, the input may be internally biased to center output signals without sync (Chroma, Pb, Pr) at ~1.25V.

All outputs are designed to drive a 150Ω DC-coupled load. Each output can be programmed to provide either 0dB or 6dB of signal gain.

Input-to-output routing and input bias mode functions are controlled via an I²C-compatible digital interface.

Block Diagram

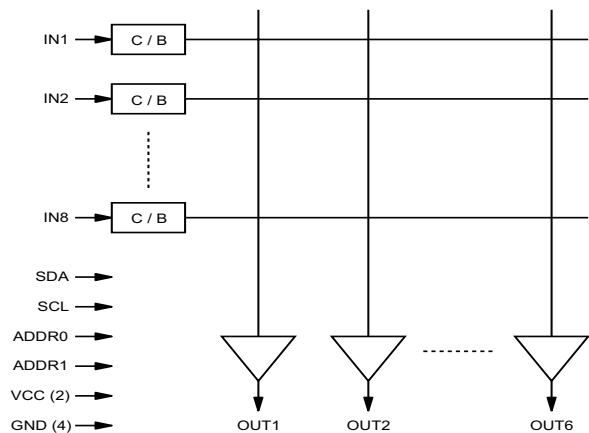

Figure 1. Block Diagram

Ordering Information

Part Number	Pb-Free	Operating Temperature Range	Package	Packing Method
FMS6502MTC24	Yes	-40°C to 85°C	24-Lead Thin Shrink Small Outline Package	Rail
FMS6502MTC24X	Yes	-40°C to 85°C	24-Lead Thin Shrink Small Outline Package	Reel

Pin Configuration

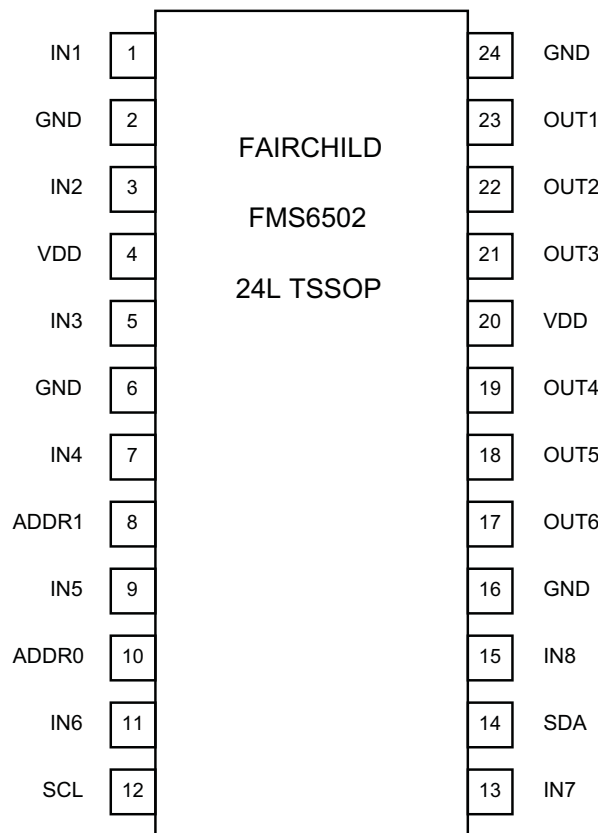

Figure 2. Pin Configuration

Pin Description

Pin#	Pin	Type	Description
1	IN1	Input	Input, channel 1
2	GND	Output	Must be tied to ground
3	IN2	Input	Input, channel 2
4	VDD	Input	Positive power supply
5	IN3	Input	Input, channel 3
6	GND	Output	Must be tied to ground
7	IN4	Input	Input, channel 4
8	ADDR1	Input	Selects I ² C address
9	IN5	Input	Input, channel 5
10	ADDR0	Input	Selects I ² C address
11	IN6	Input	Input, channel 6
12	SCL	Input	Serial clock for I ² C port
13	IN7	Input	Input, channel 7
14	SDA	Input	Serial data for I ² C port
15	IN8	Input	Input, channel 8
16	GND	Output	Must be tied to ground
17	OUT6	Output	Output, channel 6
18	OUT5	Output	Output, channel 5
19	OUT4	Output	Output, channel 4
20	VDD	Input	Positive power supply
21	OUT3	Output	Output, channel 3
22	OUT2	Output	Output, channel 2
23	OUT1	Output	Output, channel 1
24	GND	Output	Must be tied to ground

Absolute Maximum Ratings

Stresses exceeding the absolute maximum ratings may damage the device. The device may not function or be operable above the recommended operating conditions and stressing the parts to these levels is not recommended. In addition, extended exposure to stresses above the recommended operating conditions may affect device reliability. The absolute maximum ratings are stress ratings only.

Parameter	Min.	Max.	Unit
DC Supply Voltage	-0.3	6	V
Analog and Digital I/O	-0.3	$V_{CC} + 0.3$	V
Output Current Any One Channel, Do Not Exceed		40	mA

Reliability Information

Symbol	Parameter	Min.	Typ.	Max.	Unit
T_J	Junction Temperature			150	°C
T_{STG}	Storage Temperature Range	-65		150	°C
T_L	Lead Temperature (Soldering, 10s)			300	°C
Θ_{JA}	Thermal Resistance, JEDEC Standard Multi-Layer Test Boards, Still Air		84		°C/W

Recommended Operating Conditions

The Recommended Operating Conditions table defines the conditions for actual device operation. Recommended operating conditions are specified to ensure optimal performance to the datasheet specifications. Fairchild does not recommend exceeding them or designing to Absolute Maximum Ratings.

Symbol	Parameter	Min.	Typ.	Max.	Unit
T_A	Operating Temperature Range	-40		85	°C
V_{CC}	Supply Voltage Range	3.135	5.0	5.25	V

Electrostatic Discharge Information

Symbol	Parameter	Value	Unit
HBM	Human Body Model (JEDEC: JESD22-A114)	10	kV
CDM	Charged Device Model (JEDEC: JESD22-A101)	2	kV

Digital Interface

The I²C-compatible interface is used to program output enables, input-to-output routing, and input bias configuration. The I²C address of the FMS6502 is 0x06 (0000

0110) with the ability to offset based upon the values of the ADDR0 and ADDR1 inputs. Offset addresses are defined below:

ADDR1	ADDR0	Binary	Hex
0	0	0000 0110	0x06
0	1	0100 0110	0x46
1	0	1000 0110	0x86
1	1	1100 0110	0xC6

Data and address data of eight bits each are written to the FMS6502 I²C address register to access control functions.

For efficiency, a single data register is shared between two outputs for input selection. More than one output can select the same input channel for one-to-many routing.

The clamp / bias control bits are written to their own internal address since they should remain the same regardless of signal routing. They are set based on the input signal that is connected to the FMS6502.

All undefined addresses may be written without effect.

Output Control Register Contents and Defaults

Control Name	Width	Type	Default	Bit(s)	Description
In-A	4 bits	Write	0	3:0	Input selected to drive this output: 0000=OFF ¹ , 0001=IN1, 0010=IN2, 1000=IN8
In-B	4 bits	Write	0	7:4	Input selected to drive this output: 0000=OFF ¹ , 0001=IN1, 0010=IN2, 1000=IN8

Output Control Register MAP

Name	Address	Bit 7	Bit 6	Bit5	Bit4	Bit3	Bit2	Bit1	Bit0
OUT1,2	0x00	B3-Out2	B2-Out2	B1-Out2	B0-Out2	B3-Out1	B2-Out1	B1-Out1	B0-Out1
OUT3,4	0x01	B3-Out4	B2-Out4	B1-Out4	B0-Out4	B3-Out3	B2-Out3	B1-Out3	B0-Out3
OUT5,6	0x02	B3-Out6	B2-Out6	B1-Out6	B0-Out6	B3-Out5	B2-Out5	B1-Out5	B0-Out5

Clamp Control Register Contents and Defaults

Control Name	Width	Type	Default	Bit(s)	Description
Clmp	1 bit	Write	0	7:0	Clamp / Bias selection: 1 = Clamp, 0 = Bias

Clamp Control Register Map

Name	Address	Bit 7	Bit 6	Bit5	Bit4	Bit3	Bit2	Bit1	Bit0
CLAMP	0x03	Clmp8	Clmp7	Clmp6	Clmp5	Clmp4	Clmp3	Clmp2	Clmp1

Gain Control Register Contents and Defaults

Control Name	Width	Type	Default	Bit(s)	Description
Gain	1 bit	Write	0	7:0	Output Gain selection: 0 = 6dB, 1 = 0dB

Gain Control Register Map

Name	Address	Bit 7	Bit 6	Bit5	Bit4	Bit3	Bit2	Bit1	Bit0
GAIN	0x04	Unused	Unused	Gain6	Gain5	Gain4	Gain3	Gain2	Gain1

Note:

1. When the OFF input selection is used, the output amplifier is powered down and enters a high-impedance state.

DC Electrical Characteristics

$T_A = 25^\circ\text{C}$, $V_{CC} = 5\text{V}$, $V_{in} = 1V_{pp}$, input bias mode, one-to-one routing, 6dB gain, all inputs AC-coupled with $0.1\mu\text{F}$, unused inputs AC-terminated through 75Ω to GND, all outputs AC-coupled with $220\mu\text{F}$ into 150Ω , referenced to 400kHz unless otherwise noted.

Symbol	Parameter	Conditions	Min.	Typ.	Max.	Unit
I_{CC}	Supply Current ⁽¹⁾	No Load, All Outputs Enabled		55	75	mA
V_{OUT}	Video Output Range			2.8		V_{pp}
V_{clamp}	DC Input Level ⁽¹⁾	Clamp Mode, All Gain Settings	0.10	0.15	0.20	V
	DC Output Level ⁽¹⁾	Clamp Mode, 0dB Gain Setting	0.10	0.15	0.20	V
	DC Output Level ⁽¹⁾	Clamp Mode, 6dB Gain Setting	0.20	0.30	0.40	V
V_{bias}	DC Input Level ⁽¹⁾	Bias Mode, All Gain Settings	0.575	0.625	0.675	V
	DC Output Level ⁽¹⁾	Bias Mode, 0dB Gain Setting	0.575	0.625	0.700	V
	DC Output Level ⁽¹⁾	Bias Mode, 6dB Gain Setting	1.150	1.250	1.400	V
PSRR	Power Supply Rejection Ratio	All Channels, DC		90		dB

Note:

- 100% tested at 25°C .

AC Electrical Characteristics

$T_A = 25^\circ\text{C}$, $V_{CC} = 5\text{V}$, $V_{in} = 1V_{pp}$, input bias mode, one-to-one routing, 6dB gain, all inputs AC-coupled with $0.1\mu\text{F}$, unused inputs AC-terminated through 75Ω to GND, all outputs AC-coupled with $220\mu\text{F}$ into 150Ω , referenced to 400kHz unless otherwise noted.

Symbol	Parameter	Conditions	Min.	Typ.	Max.	Unit
AV_{0dB}	Channel Gain ⁽¹⁾	DC, All Channels, 0dB Gain Setting	-0.2	0	+0.2	dB
AV_{6dB}	Channel Gain ⁽¹⁾	DC, All Channels, 6dB Gain Setting	5.8	6	6.2	dB
f_{+1dB}	+1dB Peaking Bandwidth	$V_{OUT} = 1.4V_{pp}$		65		MHz
f_{-1dB}	-1dB Bandwidth	$V_{OUT} = 1.4V_{pp}$		90		MHz
f_C	-3dB Bandwidth	$V_{OUT} = 1.4V_{pp}$		115		MHz
dG	Differential Gain	$V_{CC} = 5.0\text{V}$, 3.58MHz		0.1		%
$d\phi$	Differential Phase	$V_{CC} = 5.0\text{V}$, 3.58MHz		0.2		°
THD_{SD}	SD Output Distortion	$V_{OUT} = 1.4V_{pp}$, 5MHz, $V_{CC} = 5.0\text{V}$		0.05		%
THD_{HD}	HD Output Distortion	$V_{OUT} = 1.4V_{pp}$, 22MHz, $V_{CC} = 5.0\text{V}$		0.4		%
X_{TALK1}	Input Crosstalk	1MHz, $V_{OUT} = 2V_{pp}$ ⁽²⁾		-77		dB
X_{TALK2}	Input Crosstalk	15MHz, $V_{OUT} = 2V_{pp}$ ⁽²⁾		-62		dB
X_{TALK3}	Output Crosstalk	1MHz, $V_{OUT} = 2V_{pp}$ ⁽³⁾		-81		dB
X_{TALK4}	Output Crosstalk	15MHz, $V_{OUT} = 2V_{pp}$ ⁽³⁾		-62		dB
X_{TALK5}	Multi-Channel Crosstalk	Standard Video, $V_{OUT} = 2V_{pp}$ ⁽⁴⁾		-50		dB
SNR_{SD}	Signal-to-Noise Ratio ⁽⁵⁾	NTC-7 Weighting, 4.2MHz LP, 100kHz HP		78		dB
V_{NOISE}	Channel Noise	400kHz to 100MHz, Input Referred		20		$nV/\sqrt{\text{Hz}}$
AMP_{ON}	Amplifier Recovery Time	Post I ² C Programming		300		ns

Notes:

- 100% tested at 25°C .
- Adjacent input pair to adjacent output pair. Interfering input is through an open switch.
- Adjacent input pair to adjacent output pair. Interfering input is through a closed switch.
- Crosstalk of eight synchronous switching outputs onto single, asynchronous switching output.
- $SNR = 20 * \log(714\text{mV} / \text{rms noise})$.

I²C BUS Characteristics

T_A = 25°C, V_{CC} = 5V unless otherwise noted.

Symbol	Parameter	Conditions	Min.	Typ.	Max.	Unit
V _{il}	Digital Input Low ¹	SDA,SCL,ADDR	0		1.5	V
V _{ih}	Digital Input High ¹	SDA,SCL,ADDR	3.0		V _{CC}	V
f _{SCL}	Clock Frequency	SCL		100		kHz
t _r	Input Rise Time	1.5V to 3V		1000		ns
t _f	Input Fall Time	1.5V to 3V		300		ns
t _{low}	Clock Low Period			4.7		μs
t _{high}	Clock High Period			4.0		μs
t _{SU,DAT}	Data Set-up Time			300		ns
t _{HD,DAT}	Data Hold Time			0		ns
t _{SU,STO}	Set-up Time from Clock High to Stop			4		μs
t _{BUF}	Start Set-up Time following a Stop			4.7		μs
t _{HD,STA}	Start Hold Time			4		μs
t _{SU,STA}	Start Set-up Time following Clock Low to High			4.7		μs

Note:

- 100% tested at 25°C.

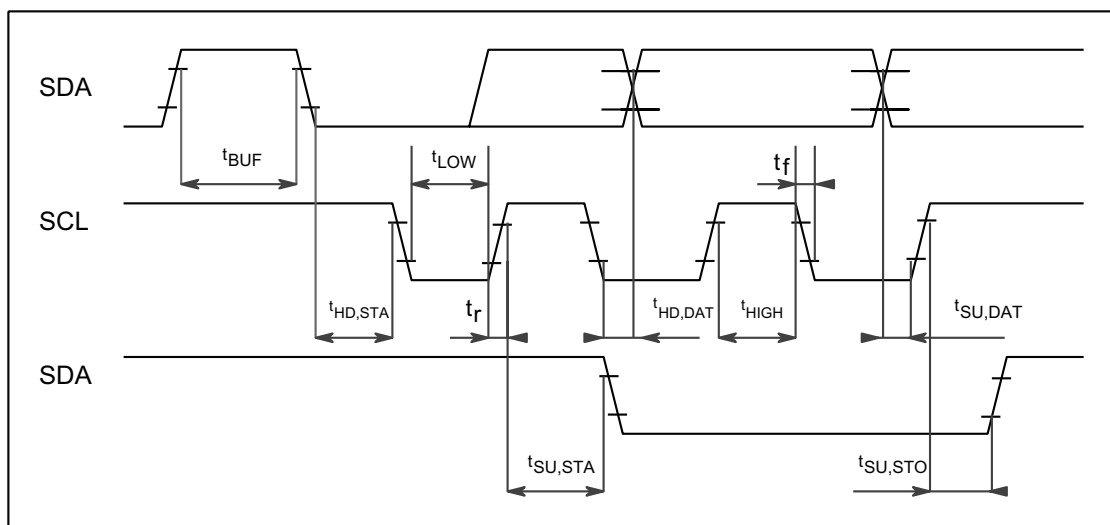

Figure 3. I²C Bus Timing

I²C Interface

Operation

The I²C-compatible interface conforms to the I²C specification for Standard Mode. Individual addresses may be written, but there is no read capability. The interface consists of two lines: a serial data line (SDA) and a serial clock line (SCL). Both lines must be connected to a positive supply through an external resistor. Data transfer may be initiated only when the bus is not busy.

Bit Transfer

One data bit is transferred during each clock pulse. The data on the SDA line must remain stable during the HIGH period of the clock pulse. Changes in the data line during this time are interpreted as control signals.

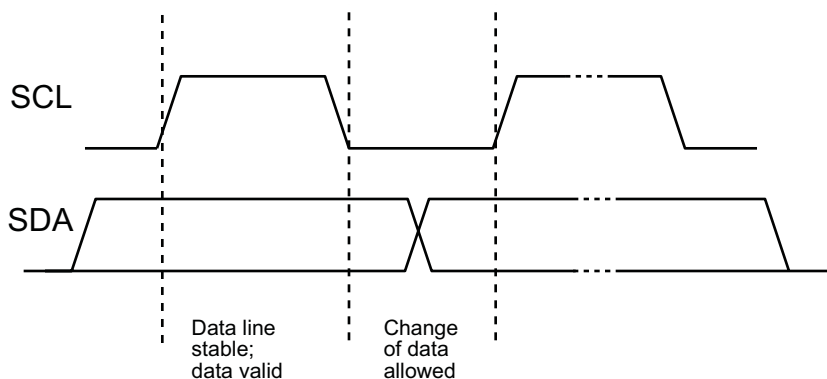

Figure 4. Bit Transfer

Start and Stop conditions

Both data and clock lines remain HIGH when the bus is not busy. A HIGH-to-LOW transition of the data line, while the clock is HIGH, is defined as start condition (S).

A LOW-to-HIGH transition of the data line, while the clock is HIGH, is defined as stop condition (P).

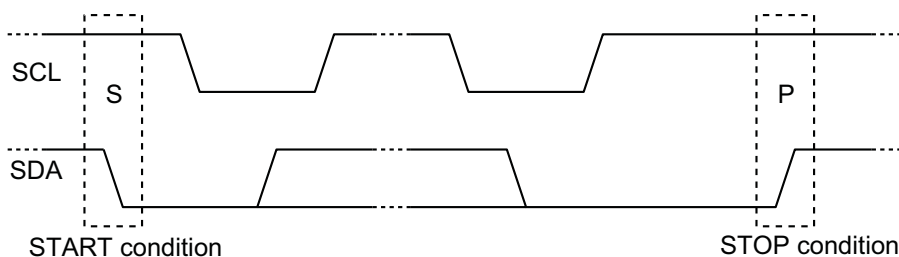

Figure 5. START and STOP conditions

Acknowledge

The number of data bytes transferred between the start and stop conditions from transmitter to receiver is unlimited. Each byte of eight bits is followed by an acknowledge bit. The acknowledge bit is a HIGH level signal put on the bus by the transmitter while the master generates an extra acknowledge-related clock pulse. The slave receiver addressed must generate an acknowledge after the reception of each byte. A master receiver must generate an acknowledge after the reception of each byte clocked out of the slave transmitter.

The device that acknowledges must pull down the SDA line during the acknowledge clock pulse so the SDA line is stable LOW during the HIGH period of the acknowledge-related clock pulse (set-up and hold times must be taken into consideration). A master receiver must signal an end of data to the transmitter by not generating an acknowledge on the last byte clocked out of the slave. In this event, the transmitter must leave the data line HIGH to enable the master to generate a stop condition.

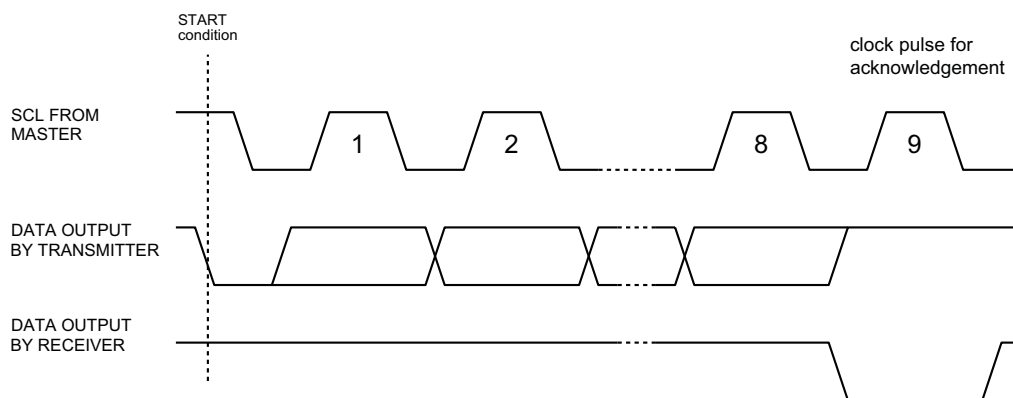

Figure 6. Acknowledgement on the I²C Bus

I²C Bus Protocol

Before any data is transmitted on the I²C bus, the device which is to respond is addressed first. The addressing is always carried out with the first byte transmitted after the

start procedure. The I²C bus configuration for a data write to the FMS6502 is shown in Figure 7.

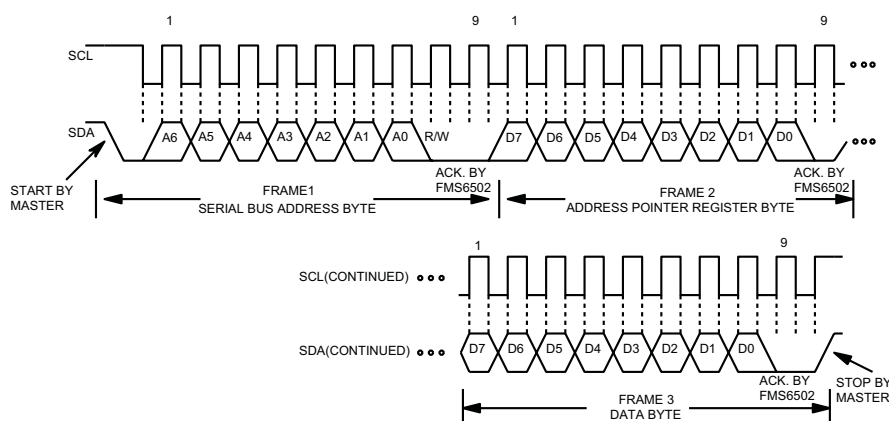

Figure 7. Write Register Address to Pointer Register; Write Data to Selected Register

3.3V Operation

The FMS6502 operates from a single 3.3V supply. With $V_{CC} = 3.3V$, the digital input low (V_{il}) is 0V to 1V and the digital input high (V_{ih}) is 1.8V to 2.9V.

Applications Information

Input Clamp / Bias Circuitry

The FMS6502 can accommodate AC- or DC-coupled inputs. Internal clamping and bias circuitry are provided to support AC-coupled inputs. These are selectable through the CLMP bits via the I²C-compatible interface. For DC-coupled inputs, the device should be programmed to use the 'bias' input configuration. In this configuration, the input is internally biased to 625mV through a 100kΩ resistor. Distortion is optimized with the output levels set between 250mV above ground and 500mV below the power supply.

With AC-coupled inputs, the FMS6502 uses a simple clamp rather than a full DC-restore circuit. For video signals with and without sync; (Y,CV,R,G,B), the lowest voltage at the output pins is clamped to approximately 300mV above ground.

If symmetric AC-coupled input signals are used (Chroma,Pb,Pr,Cb,Cr), the bias circuit can be used to center them within the input common range. The average DC value at the output is approximately 1.27V.

Figure 8 shows the clamp mode input circuit and the internally controlled voltage at the input pin for AC-coupled inputs.

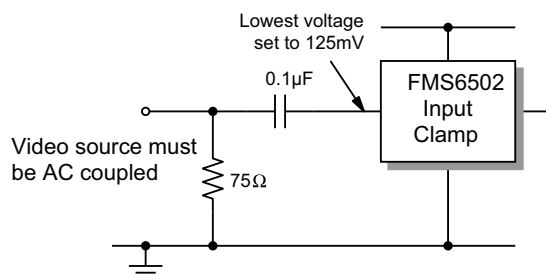

Figure 8. Clamp Mode Input Circuit

Figure 9 shows the bias mode input circuit and the internally controlled voltage at the input pin for AC-coupled inputs.

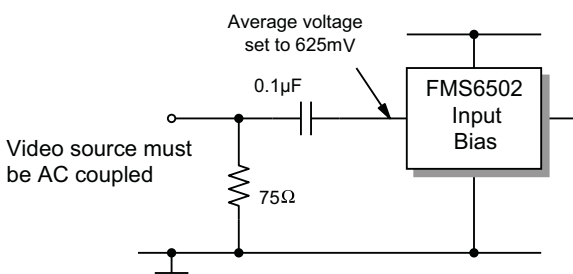

Figure 9. Bias Mode Input Circuit

Output Configuration

The FMS6502 outputs may be AC or DC-coupled. DC-coupled loads can drive a 150Ω load. AC-coupled outputs are capable of driving a single, doubly terminated video load of 150Ω. An external transistor is needed to drive DC low-impedance loads. DC-coupled outputs should be connected as indicated in Figure 10.

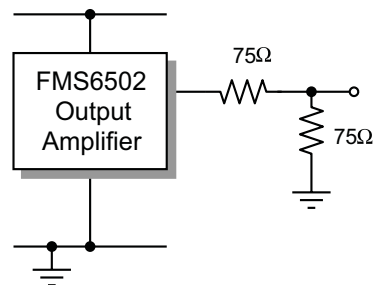

Figure 10. DC-Coupled Load Connection

Configure AC-coupled loads as shown in Figure 11.

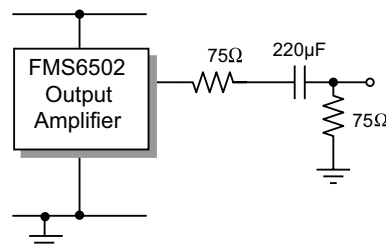

Figure 11. AC-Coupled Load Connection

When an output channel is not connected to an input, the input to that particular channel's amplifier is forced to approximately 150mV. The output amplifier is still active unless specifically disabled by the I²C interface. Voltage output levels depend on the programmed gain for that channel.

Driving Capacitive Loads

When driving capacitive loads, use a 10Ω-series resistance to buffer the output, as indicated in Figure 12.

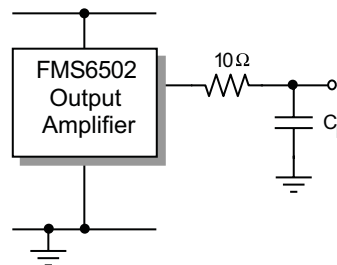

Figure 12. Driving Capacitive Loads

Crosstalk

Crosstalk is an important consideration when using the FMS6502. Input and output crosstalk represent the two major coupling modes that may be present in a typical application. Input crosstalk is crosstalk in the input pins and switches when the interfering signal drives an open switch. It is dominated by inductive coupling in the package lead frame between adjacent leads. It decreases rapidly as the interfering signal moves further away from the pin adjacent to the input signal selected. Output crosstalk is coupling from one driven output to another active output. It decreases with increasing load impedance as it is caused mainly by ground and power coupling between output amplifiers. If a signal is driving an open switch, its crosstalk is mainly input crosstalk. If it is driving a load through an active output, its crosstalk is mainly output crosstalk.

Input and output crosstalk measurements are performed with the test configuration shown in Figure 13.

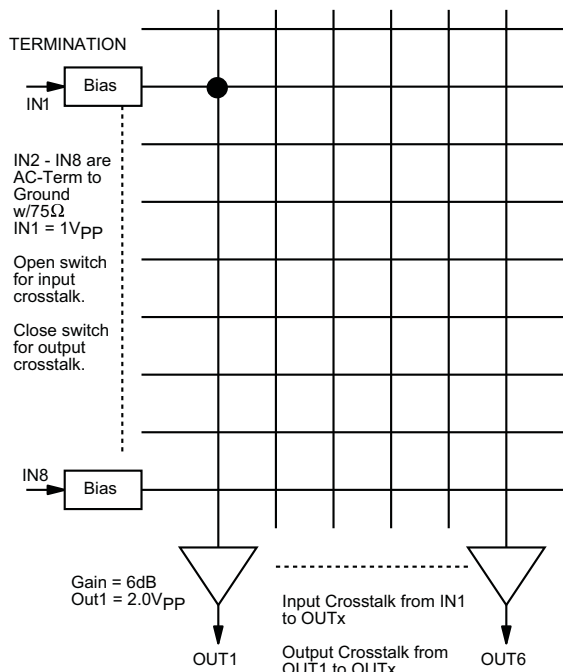

Figure 13. Test Configuration for Crosstalk

For input crosstalk, the switch is open and all inputs are in bias mode. Channel 1 input is driven with a $1V_{pp}$ signal, while all other inputs are AC terminated with 75Ω . All outputs are enabled and crosstalk is measured from IN1 to any output.

For output crosstalk, the switch is closed. Crosstalk from OUT1 to any output is measured.

Crosstalk from multiple sources into a given channel is measured with the setup shown in Figure 14. Input In1 is driven with a $1V_{pp}$ pulse source and connected to outputs Out1 to Out8. Input In9 is driven with a secondary, asynchronous gray field video signal and is connected to Out9. All other inputs are AC terminated with 75Ω . Crosstalk effects on the gray field are measured and calculated with respect to a standard $1V_{pp}$ output measured at the load.

If not all inputs and outputs are needed, avoid using adjacent channels to reduce crosstalk.

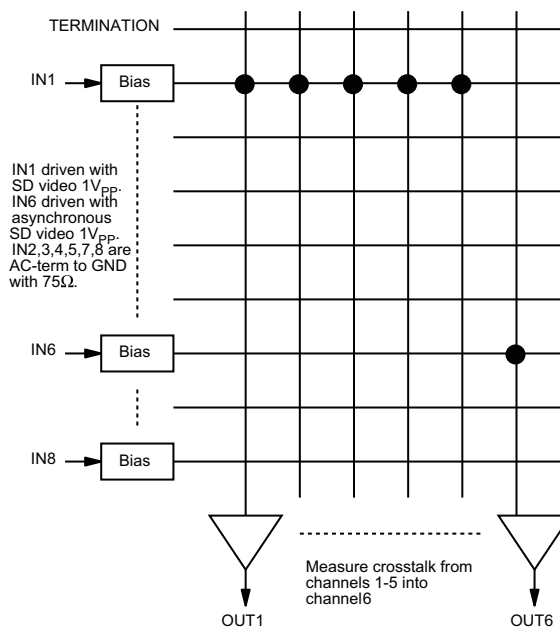

Figure 14. Test Configuration for Multi-Channel Crosstalk

Layout Considerations

General layout and supply bypassing play a major role in high-frequency performance and thermal characteristics. Fairchild offers a demonstration board to guide layout and aid device evaluation. The demo board is a four-layer board with full power and ground planes. Following this layout configuration provides optimum performance and thermal characteristics for the device. For the best results, follow the steps and recommended routing rules listed below.

Recommended Routing/Layout Rules

- Do not run analog and digital signals in parallel.
- Use separate analog and digital power planes to supply power.
- Traces should run on top of the ground plane at all times.
- No trace should run over ground/power splits.
- Avoid routing at 90-degree angles.
- Minimize clock and video data trace length differences.
- Include 10 μ F and 0.1 μ F ceramic power supply bypass capacitors.
- Place the 0.1 μ F capacitor within 0.1 inches of the device power pin.
- Place the 10 μ F capacitor within 0.75 inches of the device power pin.
- For multilayer boards, use a large ground plane to help dissipate heat.
- For two-layer boards, use a ground plane that extends beyond the device body by at least 0.5 inches on all sides. Include a metal paddle under the device on the top layer.
- Minimize all trace lengths to reduce series inductance.

Thermal Considerations

Since the interior of most systems, such as set-top boxes, TVs, and DVD players, are at +70°C; consideration must be given to providing an adequate heat sink for the device package for maximum heat dissipation. When designing a system board, determine how much power each device dissipates. Ensure that devices of high power are not placed in the same location, such as directly above (top plane) or below (bottom plane) each other on the PCB.

PCB Thermal Layout Considerations

- Understand the system power requirements and environmental conditions.
- Maximize thermal performance of the PCB.
- Consider using 70 μ m of copper for high-power designs.

- Make the PCB as thin as possible by reducing FR4 thickness.
- Use vias in power pad to tie adjacent layers together.
- Remember that baseline temperature is a function of board area, not copper thickness.
- Modeling techniques can provide a first-order approximation.

Power Dissipation

Worst-case, additional die power due to DC loading can be estimated at $V_{CC}^2/4R_{load}$ per output channel. This assumes a constant DC output voltage of $V_{CC}/2$. For 5V V_{CC} with a dual DC video load, add $25/(4*75) = 83mW$, per channel.

Applications for the FMS6502 Video Switch Matrix

The increased demand for consumer multimedia systems has created a large challenge for system designers to provide cost-effective solutions to capitalize on the growth potential in graphics display technologies. These applications require cost-effective video switching and filtering solutions to deploy high-quality display technologies rapidly and effectively to the target audience. Areas of specific interest include HDTV, media centers, and automotive infotainment (such as navigation, in-cabin entertainment, and back-up cameras). In all cases, the advantages the integrated video switch matrix provides are high-quality video switching specific to the application, as well as video input clamps and on-chip, low-impedance output cable drivers with switchable gain.

Generally the largest application for a video switch is for the front-end of an HDTV. This is used to take multiple inputs and route them to their appropriate signal paths (main picture and picture-in-picture, or PiP). These are normally routed into ADCs that are followed by decoders. Technologies for HDTV include LCD, plasma, and CRT, which have similar analog switching circuitry.

VIPDEMO™ Control Software

The FMS6502 is configured via an I²C-compatible digital interface. To facilitate demonstration, Fairchild Semiconductor had developed the VIPDEMO™ GUI-based control software to write to the FMS6502 register map. This software is included in the FMS6502DEMO kit. A parallel port I²C adapter and an interface cable to connect to the demo board are also included. Besides using the full FMS6502 interface, the VIPDEMO™ can also be used to control single register read and writes for I²C.

Physical Dimensions

Dimensions are in millimeters unless otherwise noted.

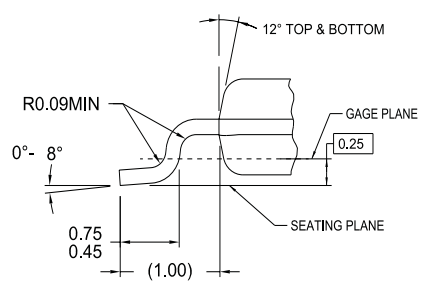
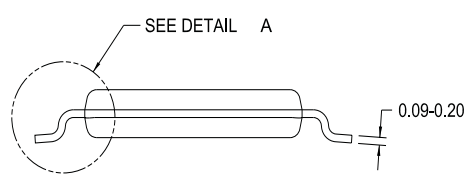
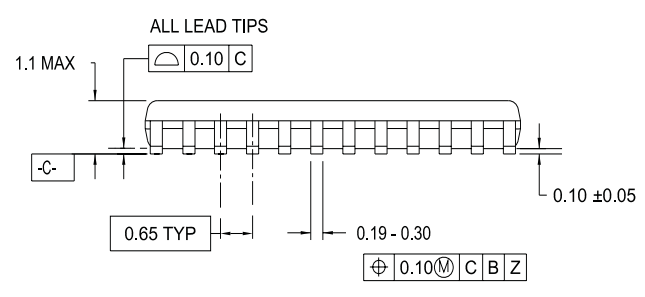
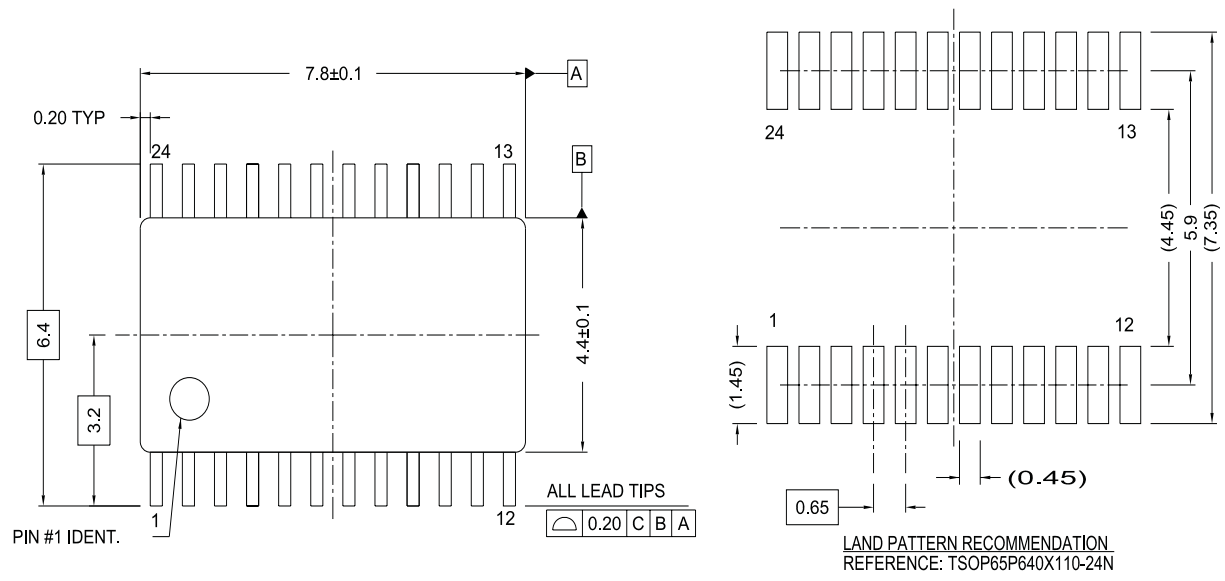

DIMENSIONS ARE IN MILLIMETERS

- NOTES:
- A. CONFORMS TO JEDEC REGISTRATION MO-153, VARIATION AD, DATE 10/97.
 - B. DIMENSIONS ARE IN MILLIMETERS.
 - C. DIMENSIONS ARE EXCLUSIVE OF BURRS, MOLD FLASH, AND TIE BAR EXTRUSIONS.
 - D. DIMENSIONS AND TOLERANCES PER ANSI Y14.5M, 1994
 - E. DRAWING FILE NAME: MTC24REV4

MTC24REV4

Figure 15. 24-Lead Thin Shrink Small Outline Package

TRADEMARKS

The following are registered and unregistered trademarks Fairchild Semiconductor owns or is authorized to use and is not intended to be an exhaustive list of all such trademarks.

ACEx™	FACT Quiet Series™	OCX™	SILENT SWITCHER®	UniFET™
ActiveArray™	GlobalOptoisolator™	OCXPro™	SMART START™	VCX™
Bottomless™	GTO™	OPTOLOGIC®	SPM™	Wire™
Build it Now™	HiSeC™	OPTOPLANAR™	Stealth™	
CoolFET™	I ² C™	PACMAN™	SuperFET™	
CROSSVOLT™	i-Lo™	POP™	SuperSOT™-3	
DOME™	ImpliedDisconnect™	Power247™	SuperSOT™-6	
EcoSPARK™	IntelliMAX™	PowerEdge™	SuperSOT™-8	
E ² CMOS™	ISOPLANAR™	PowerSaver™	SyncFET™	
EnSigna™	LittleFET™	PowerTrench®	TCM™	
FACT®	MICROCOUPLER™	QFET®	TinyBoost™	
FAST®	MicroFET™	QS™	TinyBuck™	
FASTr™	MicroPak™	QT Optoelectronics™	TinyPWM™	
FPS™	MICROWIRE™	Quiet Series™	TinyPower™	
FRFET™	MSX™	RapidConfigure™	TinyLogic®	
	MSXPro™	RapidConnect™	TINYOPTO™	
Across the board. Around the world.™		µSerDes™	TruTranslation™	
The Power Franchise®		ScalarPump™	UHC®	
Programmable Active Droop™				

DISCLAIMER

FAIRCHILD SEMICONDUCTOR RESERVES THE RIGHT TO MAKE CHANGES WITHOUT FURTHER NOTICE TO ANY PRODUCTS HEREIN TO IMPROVE RELIABILITY, FUNCTION, OR DESIGN. FAIRCHILD DOES NOT ASSUME ANY LIABILITY ARISING OUT OF THE APPLICATION OR USE OF ANY PRODUCT OR CIRCUIT DESCRIBED HEREIN; NEITHER DOES IT CONVEY ANY LICENSE UNDER ITS PATENT RIGHTS, NOR THE RIGHTS OF OTHERS. THESE SPECIFICATIONS DO NOT EXPAND THE TERMS OF FAIRCHILD'S WORLDWIDE TERMS AND CONDITIONS, SPECIFICALLY THE WARRANTY THEREIN, WHICH COVERS THESE PRODUCTS.

LIFE SUPPORT POLICY

FAIRCHILD'S PRODUCTS ARE NOT AUTHORIZED FOR USE AS CRITICAL COMPONENTS IN LIFE SUPPORT DEVICES OR SYSTEMS WITHOUT THE EXPRESS WRITTEN APPROVAL OF FAIRCHILD SEMICONDUCTOR CORPORATION.

As used herein:

- Life support devices or systems are devices or systems which, (a) are intended for surgical implant into the body, or (b) support or sustain life, or (c) whose failure to perform when properly used in accordance with instructions for use provided in the labeling, can be reasonably expected to result in significant injury to the user.
- A critical component is any component of a life support device or system whose failure to perform can be reasonably expected to cause the failure of the life support device or system, or to affect its safety or effectiveness.

PRODUCT STATUS DEFINITIONS

Definition of Terms

Datasheet Identification	Product Status	Definition
Advance Information	Formative or In Design	This datasheet contains the design specifications for product development. Specifications may change in any manner without notice.
Preliminary	First Production	This datasheet contains preliminary data, and supplementary data will be published at a later date. Fairchild Semiconductor reserves the right to make changes at any time without notice to improve design.
No Identification Needed	Full Production	This datasheet contains final specifications. Fairchild Semiconductor reserves the right to make changes at any time without notice to improve design.
Obsolete	Not In Production	This datasheet contains specifications on a product that has been discontinued by Fairchild semiconductor. The datasheet is printed for reference information only.

Rev. I22