



FNB81060T3

Motion SPM[®] 8 Series

Features

- 600 V - 10 A 3-Phase IGBT Inverter Including Control IC for Gate Drive and Protections
- Low-Loss, Short-Circuit Rated IGBTs
- Separate Open-Emitter Pins from Low-Side IGBTs for Three-Phase Current Sensing
- Active-high interface, works with 3.3 / 5 V Logic, Schmitt-trigger Input
- HVIC for Gate Driving, Under-Voltage, Over Current and Short-Circuit Current Protection
- Fault Output for Under-Voltage, Over Current and Short-Circuit Current Protection
- Inter-Lock Function to Prevent Short-Circuit
- Shut-Down Input
- HVIC Temperature-Sensing Built-In for Temperature Monitoring
- Isolation Rating: 1500 V_{rms} / min.

Applications

- Motion Control - Home Appliance / Industrial Motor / HVAC.

Related Resources

- [AN-9112 - Smart Power Module, Motion SPM[®] 8 Series User's Guide.](#)

General Description

FNB81060T3 is a Motion SPM 8 module providing a fully-featured, high-performance inverter output stage for AC Induction, BLDC, and PMSM motors. These modules integrate optimized gate drive of the built-in IGBTs to minimize EMI and losses, while also providing multiple on-module protection features including under-voltage lockouts, inter-lock function, over-current shutdown, thermal monitoring of drive IC, and fault reporting. The built-in, high-speed HVIC requires only a single supply voltage and translates the incoming logic-level gate inputs to the high-voltage, high-current drive signals required to properly drive the module's robust short-circuit-rated IGBTs. Separate negative IGBT terminals are available for each phase to support the widest variety of control algorithms.

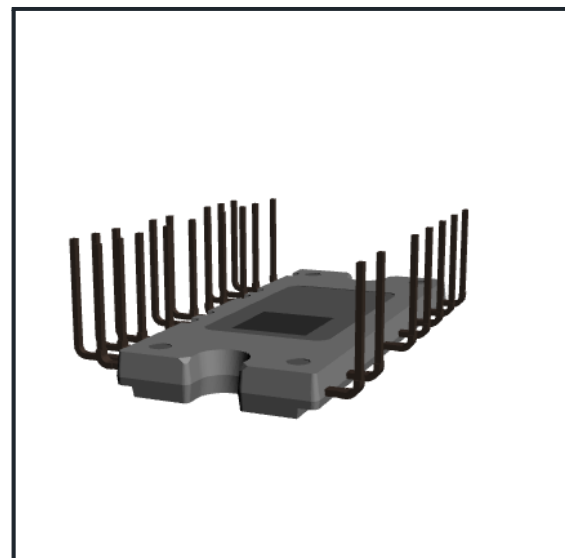

SPM25-FAA

Figure 1. 3D Package Drawing
(Click to Activate 3D Content)

Package Marking and Ordering Information

Device	Device Marking	Package	Packing Type	Quantity
FNB81060T3	NB81060T3	SPM25-FAA	RAIL	15

Integrated Power Functions

- 600 V - 10 A IGBT inverter for three phase DC / AC power conversion (*Please refer to Figure 3*)

Integrated Drive, Protection and System Control Functions

- For inverter high-side IGBTs: gate drive circuit, high-voltage isolated high-speed level shifting control circuit Under-Voltage Lock-Out (UVLO) protection
- For inverter low-side IGBTs: gate drive circuit, Over Current Protection(OCP), Short-Circuit Protection (SCP) control supply circuit Under-Voltage Lock-Out (UVLO) protection
- Fault signaling: corresponding to UVLO (low-side supply) and SC faults
- Input interface: High-active interface, works with 3.3 / 5 V logic, Schmitt trigger input

Pin Configuration

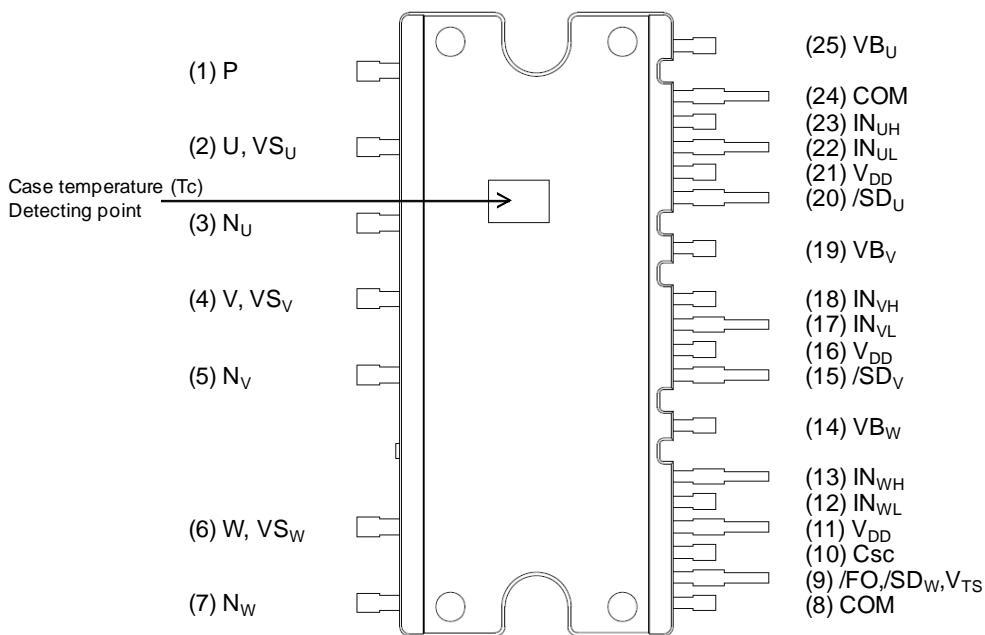

Figure 2. Top View

Pin Descriptions

Pin Number	Pin Name	Pin Description
1	P	Positive DC-Link Input
2	U, VS _U	Output for U Phase
3	N _U	Negative DC-Link Input for U Phase
4	V, VS _V	Output for V Phase
5	N _V	Negative DC-Link Input for V Phase
6	W, VS _W	Output for W Phase
7	N _W	Negative DC-Link Input for W Phase
8	COM	Common Supply Ground
9	/FO, /SD _W , V _{TS}	Fault Output, Shut-Down Input for W Phase, Temperature Output of Drive IC
10	C _{SC}	Shut Down Input for Over Current and Short Circuit Protection
11	V _{DD}	Common Bias Voltage for IC and IGBTs Driving
12	IN _{WL}	Signal Input for Low-Side W Phase
13	IN _{WH}	Signal Input for High-Side W Phase
14	VB _W	High-Side Bias Voltage for W-Phase IGBT Driving
15	/SD _V	Shut-Down Input for V Phase
16	V _{DD}	Common Bias Voltage for IC and IGBTs Driving
17	IN _{VL}	Signal Input for Low-Side V Phase
18	IN _{VH}	Signal Input for High-Side V Phase
19	VB _V	High-Side Bias Voltage for V-Phase IGBT Driving
20	/SD _U	Shut-Down Input for U Phase
21	V _{DD}	Common Bias Voltage for IC and IGBTs Driving
22	IN _{UL}	Signal Input for Low-Side U Phase
23	IN _{UH}	Signal Input for High-Side U Phase
24	COM	Common Supply Ground
25	VB _U	High-Side Bias Voltage for U-Phase IGBT Driving

Internal Equivalent Circuit and Input/Output Pins

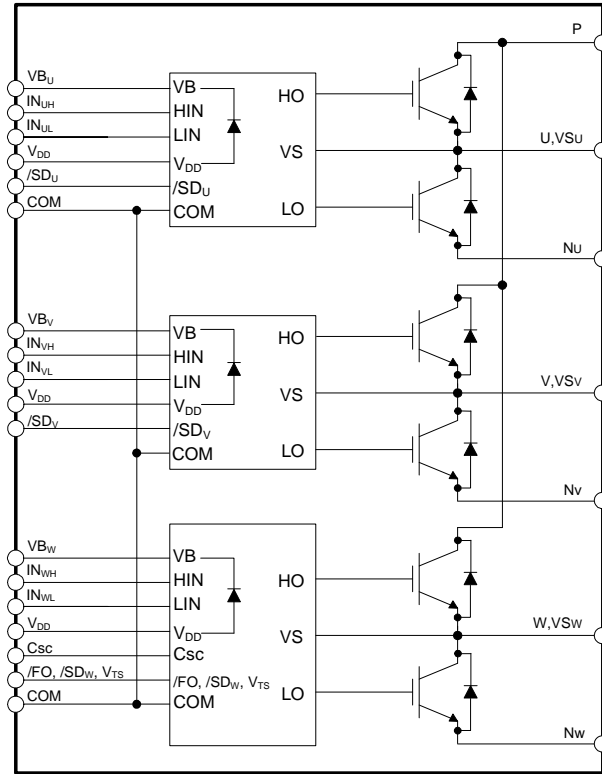

Figure 3. Internal Block Diagram

Note:

1. Inverter high-side is composed of three IGBTs, freewheeling diodes.
2. Inverter low-side is composed of three IGBTs, freewheeling diodes.
3. Inverter power side is composed of four inverter DC-link input terminals and three inverter output terminals.

Absolute Maximum Ratings ($T_J = 25^\circ\text{C}$, unless otherwise specified.)

Inverter Part

Symbol	Parameter	Conditions	Rating	Unit
V_{PN}	Supply Voltage	Applied between P - N_U , N_V , N_W	450	V
$V_{PN(\text{Surge})}$	Supply Voltage (Surge)	Applied between P - N_U , N_V , N_W	500	V
V_{CES}	Collector - Emitter Voltage		600	V
$\pm I_C$	Each IGBT Collector Current	$T_C = 25^\circ\text{C}$, $T_J \leq 150^\circ\text{C}$ (Note 4)	10	A
$\pm I_{CP}$	Each IGBT Collector Current (Peak)	$T_C = 25^\circ\text{C}$, $T_J \leq 150^\circ\text{C}$, Under 1 ms Pulse Width (Note 4)	20	A
T_J	Operating Junction Temperature		-40 ~ 150	$^\circ\text{C}$

Control Part

Symbol	Parameter	Conditions	Rating	Unit
V_{DD}	Control Supply Voltage	Applied between V_{DD} - COM	20	V
V_{BS}	High-Side Control Bias Voltage	Applied between V_{BU} - V_{SU} , V_{BV} - V_{SV} , V_{BW} - V_{SW}	20	V
V_{IN}	Input Signal Voltage	Applied between IN_{UH} , IN_{VH} , IN_{WH} , IN_{UL} , IN_{VL} , IN_{WL} - COM	-0.3 ~ $V_{DD} + 0.3$	V
V_{FS}	Function Supply Voltage	Applied between /FO, /SD _W , V_{TS} - COM	-0.3 ~ $V_{DD} + 0.3$	V
I_{FO}	Fault Current	Sink Current at /FO, /SD _W , V_{TS} pin	2	mA
V_{SC}	Current Sensing Input Voltage	Applied between C_{SC} - COM	-0.3 ~ $V_{DD} + 0.3$	V

Total System

Symbol	Parameter	Conditions	Rating	Unit
$V_{PN(\text{PROT})}$	Self Protection Supply Voltage Limit (Short Circuit Protection Capability)	$V_{DD} = V_{BS} = 13.5 \sim 16.5 \text{ V}$, $T_J = 150^\circ\text{C}$, Non-Repetitive, < 2 μs	400	V
T_C	Module Case Operation Temperature	See Figure 2	-40 ~ 125	$^\circ\text{C}$
T_{STG}	Storage Temperature		-40 ~ 125	$^\circ\text{C}$
V_{ISO}	Isolation Voltage Connect Pins to Heat Sink Plate	AC 60 Hz, Sinusoidal, 1 Minute, Connection Pins to Heat Sink Plate	1500	V_{rms}

Thermal Resistance

Symbol	Parameter	Conditions	Min.	Typ.	Max.	Unit
$R_{th(j-c)Q}$	Junction to Case Thermal Resistance (Note 4)	Inverter IGBT part, (Per Module)	-	-	3.40	$^\circ\text{C} / \text{W}$
$R_{th(j-c)F}$		Inverter FWDi part (Per Module)	-	-	3.86	$^\circ\text{C} / \text{W}$

Note:

4. For the measurement point of case temperature (T_C), please refer to Figure 2.

Electrical Characteristics ($T_J = 25^\circ\text{C}$, unless otherwise specified.)

Inverter Part

Symbol	Parameter	Conditions	Min.	Typ.	Max.	Unit	
$V_{CE(SAT)}$	Collector - Emitter Saturation Voltage	$V_{DD} = V_{BS} = 15\text{ V}$ $V_{IN} = 5\text{ V}$ $I_C = 8\text{ A}$	$T_J = 25^\circ\text{C}$	-	1.50	2.10	V
			$T_J = 150^\circ\text{C}$	-	1.80	-	V
V_F	FWDi Forward Voltage	$V_{IN} = 0\text{ V}$ $I_F = 8\text{ A}$	$T_J = 25^\circ\text{C}$	-	1.90	2.50	V
			$T_J = 150^\circ\text{C}$	-	1.80	-	V
HS	t_{ON}	Switching Times $V_{PN} = 400\text{ V}, V_{DD} = V_{BS} = 15\text{ V}, I_C = 10\text{ A}$ $T_J = 25^\circ\text{C}$ $V_{IN} = 0\text{ V} \leftrightarrow 5\text{ V}$, Inductive load (Note 5)		0.25	0.75	1.25	us
			$t_{C(ON)}$	-	0.15	0.45	us
			t_{OFF}	-	0.50	1.00	us
			$t_{C(OFF)}$	-	0.10	0.40	us
			t_{rr}	-	0.10	-	us
LS	t_{ON}	$V_{PN} = 400\text{ V}, V_{DD} = V_{BS} = 15\text{ V}, I_C = 10\text{ A}$ $T_J = 25^\circ\text{C}$ $V_{IN} = 0\text{ V} \leftrightarrow 5\text{ V}$, Inductive load (Note 5)		0.25	0.75	1.25	us
			$t_{C(ON)}$	-	0.15	0.45	us
			t_{OFF}	-	0.50	1.00	us
			$t_{C(OFF)}$	-	0.10	0.40	us
			t_{rr}	-	0.10	-	us
I_{CES}	Collector - Emitter Leakage Current	$V_{CE} = V_{CES}$	-	-	1.00	mA	

Note:

5. t_{ON} and t_{OFF} include the propagation delay of the internal drive IC. $t_{C(ON)}$ and $t_{C(OFF)}$ are the switching time of IGBT itself under the given gate driving condition internally. For the detailed information, please see Figure 4.

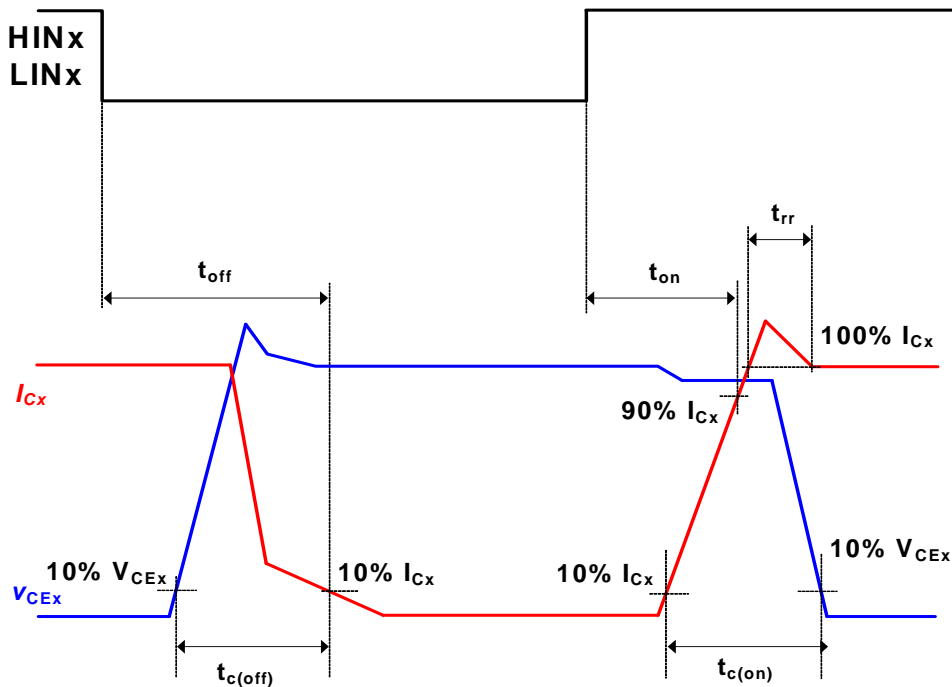

Figure 4. Switching Time Definition

Control Part

Symbol	Parameter	Conditions	Min.	Typ.	Max.	Unit	
I_{QDD}	Quiescent V_{DD} Supply Current	$V_{DD} = 15\text{ V}$, $IN_{(UH, VH, WH, UL, VL, WL)} = 0\text{ V}$	$V_{DD} - COM$	-	-	1.7	mA
I_{PDD}	Operating V_{DD} Supply Current	$V_{DD} = 15\text{ V}$, $f_{PWM} = 20\text{ kHz}$, duty = 50%, applied to one PWM signal input	$V_{DD} - COM$	-	-	2.2	mA
I_{QBS}	Quiescent V_{BS} Supply Current	$V_{BS} = 15\text{ V}$, $IN_{(UH, VH, WH)} = 0\text{ V}$	$VB_U - VS_U$, $VB_V - VS_V$, $VB_W - VS_W$	-	-	100	μA
I_{PBS}	Operating V_{BS} Supply Current	$V_{DD} = V_{BS} = 15\text{ V}$, $f_{PWM} = 20\text{ kHz}$, duty = 50%, applied to one PWM signal input for high - side	$VB_U - VS_U$, $VB_V - VS_V$, $VB_W - VS_W$	-	-	600	μA
V_{FOH}	Fault Output Voltage	$V_{SC} = 0\text{ V}$, /FO Circuit: 10 k Ω to 5 V Pull-up	4.5	-	-	V	
V_{FOL}		$V_{SC} = 1\text{ V}$, /FO Circuit: 10 k Ω to 5 V Pull-up	-	-	0.5	V	
$V_{SC(ref)}$	Short-Circuit Trip Level	$V_{DD} = 15\text{ V}$ (Note 6)	0.45	0.50	0.55	V	
UV_{DDD}	Supply Circuit Under-Voltage Protection	Detection level	10.0	11.5	13.0	V	
UV_{DDR}		Reset level	10.5	12.0	13.5	V	
UV_{BSD}		Detection level	9.5	11.0	12.5	V	
UV_{BSR}		Reset level	10.0	11.5	13.0	V	
I_{FO_T}	HVIC Temperature Sensing Current	$V_{DD} = V_{BS} = 15\text{ V}$, $T_{HVIC} = 25^\circ\text{C}$	-	80	-	μA	
V_{FO_T}	HVIC Temperature Sensing Voltage	$V_{DD} = V_{BS} = 15\text{ V}$, $T_{HVIC} = 25^\circ\text{C}$, 10 k Ω to 5 V Pull-up See Figure 5	-	4.2	-	V	
t_{FOD}	Fault-Out Pulse Width		40	-	-	μs	
V_{FSDR}	Shut-down Reset level	Applied between /FO - COM	-	-	2.4	V	
V_{FSDD}	Shut-down Detection level		0.8	-	-	V	
$V_{IN(ON)}$	ON Threshold Voltage	Applied between IN_{UH} , IN_{VH} , IN_{WH} , IN_{UL} , IN_{VL} , IN_{WL} - COM	-	-	2.4	V	
$V_{IN(OFF)}$	OFF Threshold Voltage		0.8	-	-	V	

Note:

6. Short-circuit current protection function is for all six IGBTs if the /FO, /SD_W, V_{TS} pin is connected to /SD_x pins.

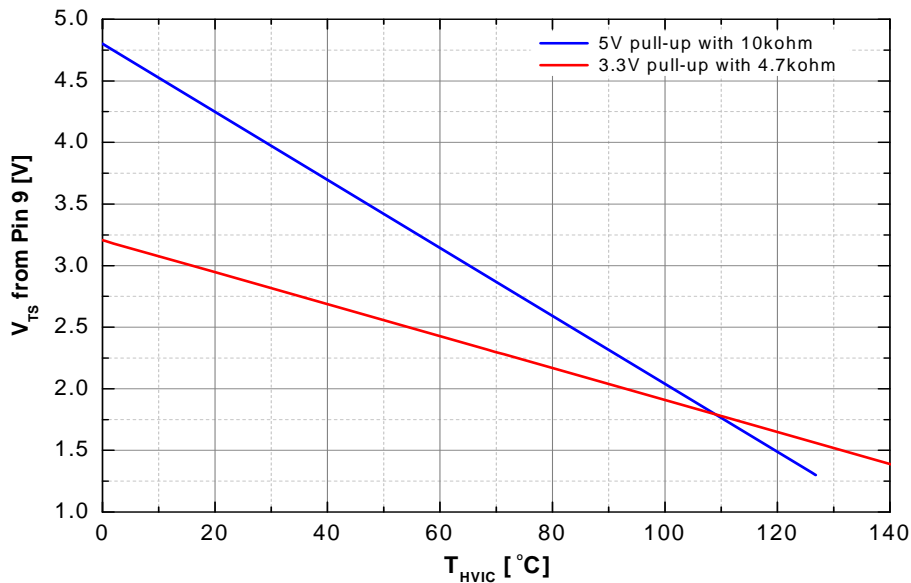

Figure 5. V-T Curve of Temperature Output of IC

Bootstrap Diode Part

Symbol	Parameter	Conditions	Min.	Typ.	Max.	Unit
R _{BS}	Bootstrap Diode Resitance	V _{DD} = 15V, T _C = 25°C	-	280	-	Ω

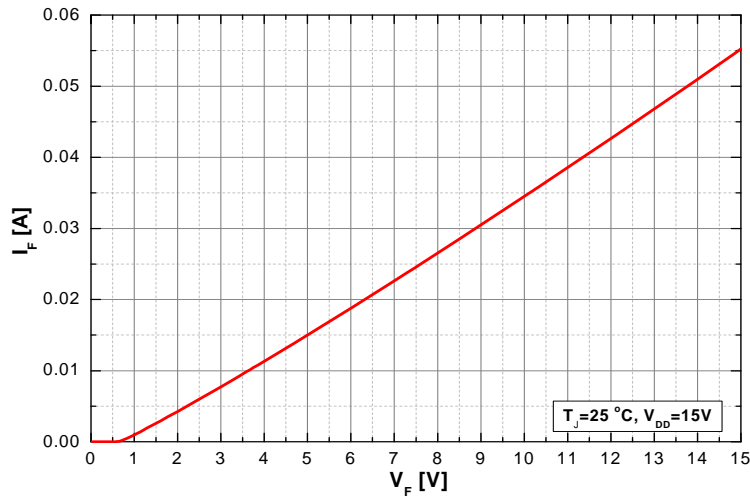

Figure 6. Built-In Bootstrap Diode Charaterstics

Recommended Operating Conditions

Symbol	Parameter	Conditions	Min.	Typ.	Max.	Unit
V _{PN}	Supply Voltage	Applied between P - N _U , N _V , N _W	-	300	400	V
V _{DD}	Control Supply Voltage	Applied between V _{DD} - COM	14.0	15	16.5	V
V _{BS}	High - Side Bias Voltage	Applied between V _{B_U} - V _{S_U} , V _{B_V} - V _{S_V} , V _{B_W} - V _{S_W}	13.0	15	18.5	V
dV _{DD} / dt, dV _{BS} / dt	Control Supply Variation		-1	-	1	V / μs
t _{dead}	Blanking Time for Preventing Arm - Short	For each input signal	0.5	-	-	μs
V _{SEN}	Voltage for Current Sensing	Applied between N _U , N _V , N _W - COM (Including surge voltage)	-4		4	V
P _{WIN(ON)}	Minimum Input Pulse Width	V _{DD} = V _{BS} = 15 V, I _C ≤ 20 A, Wiring Inductance between N _U , V, W and DC Link N < 10nH (Note 8)	0.7	-	-	μs
P _{WIN(OFF)}			0.7	-	-	

Note:

7. This product might not make response if input pulse width is less than the recommended value.

Mechanical Characteristics and Ratings

Parameter	Conditions	Min.	Typ.	Max.	Unit	
Device Flatness	See Figure 7	-50	-	100	μm	
Mounting Torque	Mounting Screw: - M3	Recommended 0.7 N • m	0.6	0.7	0.8	N • m
	See Figure 8	Recommended 7.1 kg • cm	5.9	6.9	7.9	kg • cm
Weight		-	5.0	-	g	

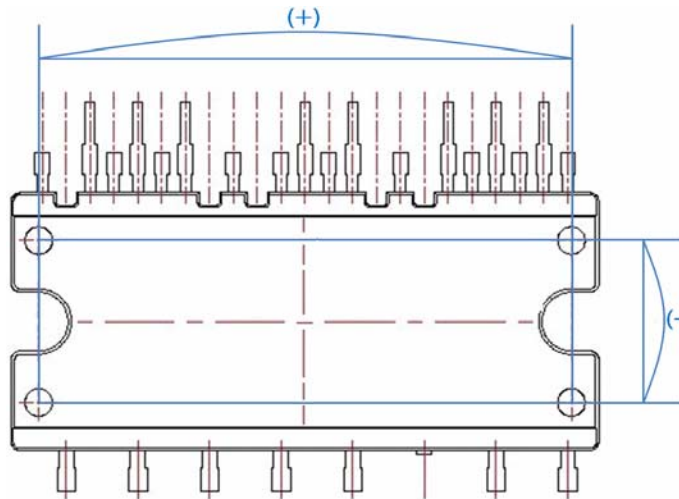

Figure 7. Flatness Measurement Position

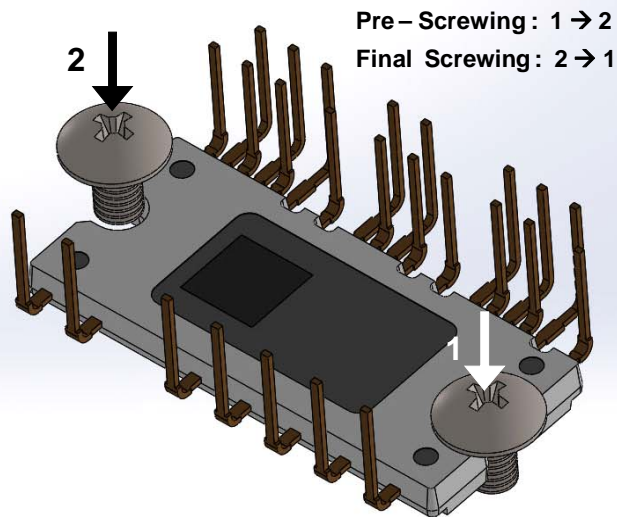

Figure 8. Mounting Screws Torque Order

Note:

- 8. Do not make over torque when mounting screws. Much mounting torque may cause package cracks, as well as bolts and Al heat-sink destruction.
- 9. Avoid one side tightening stress. Figure 8 shows the recommended torque order for mounting screws. Uneven mounting can cause the package to be damaged.
The pre-screwing torque is set to 20 ~ 30 % of maximum torque rating.

Time Charts of Protective Function

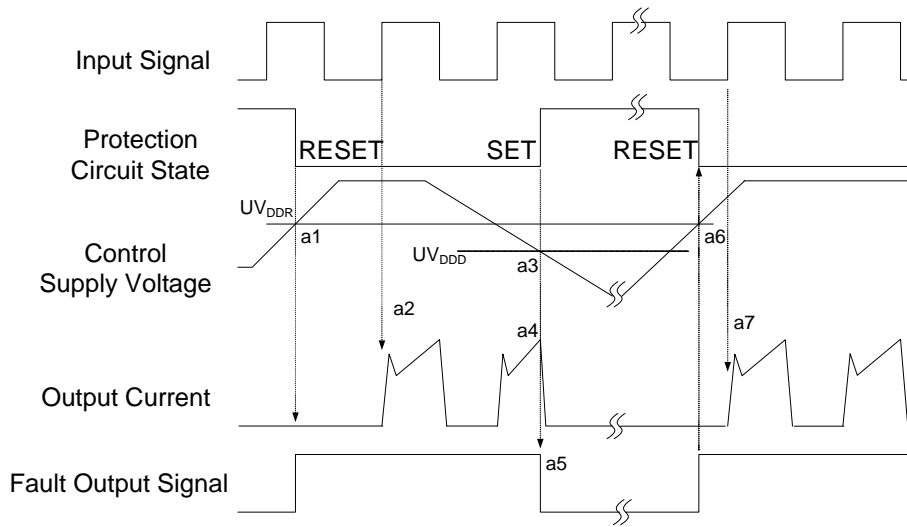

Figure 9. Under-Voltage Protection (Low-Side)

- a1 : Control supply voltage rises: After the voltage rises UV_{DDR} , the circuits start to operate when next input is applied.
- a2 : Normal operation: IGBT ON and carrying current.
- a3 : Under voltage detection (UV_{DDD}).
- a4 : IGBT OFF in spite of control input condition.
- a5 : Fault output operation starts.
- a6 : Under voltage reset (UV_{DDR}).
- a7 : Normal operation: IGBT ON and carrying current.

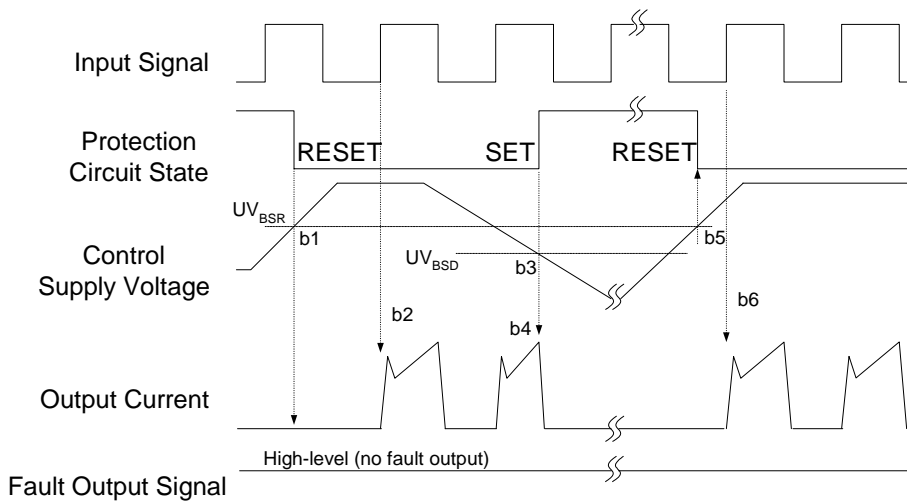

Figure 10. Under-Voltage Protection (High-Side)

- b1 : Control supply voltage rises: After the voltage reaches UV_{BSR} , the circuits start to operate when next input is applied.
- b2 : Normal operation: IGBT ON and carrying current.
- b3 : Under voltage detection (UV_{BSD}).
- b4 : IGBT OFF in spite of control input condition, but there is no fault output signal.
- b5 : Under voltage reset (UV_{BSR})
- b6 : Normal operation: IGBT ON and carrying current

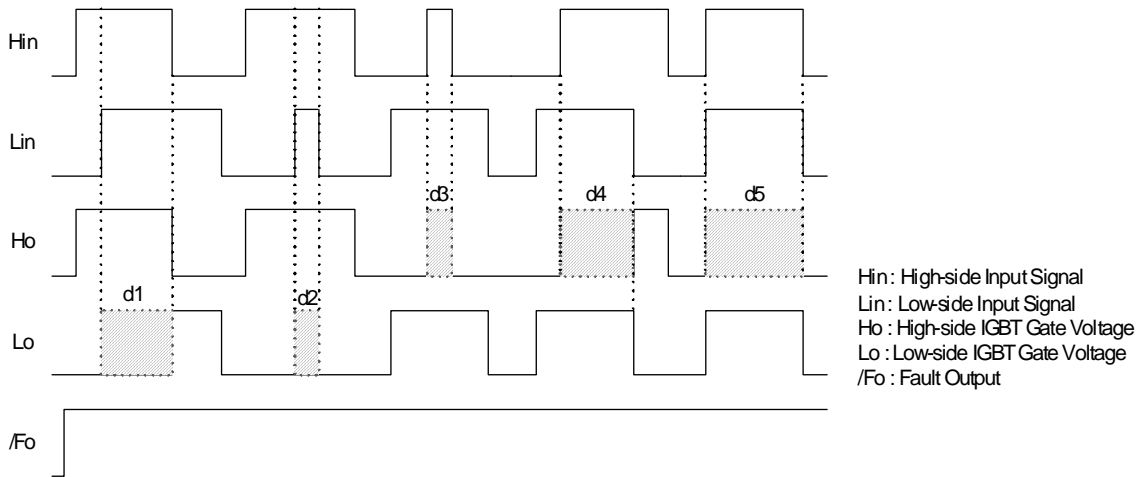

Figure 11. Inter-Lock Function

- d1 : High Side First - Input - First - Output Mode
- d2 : Low Side Noise Mode : No LO
- d3 : High Side Noise Mode : No HO
- d4 : Low Side First - Input - First - Output Mode
- d5 : IN - Phase Mode : No HO

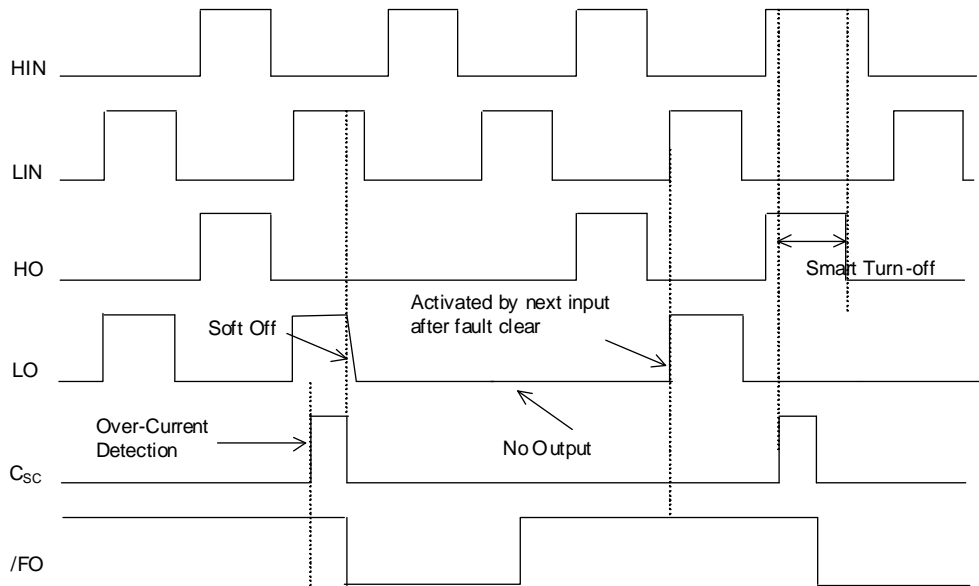

Figure 12. Fault-Out Function By Over Current Protection

- HIN : High-side Input Signal
- LIN : Low-side Input Signal
- HO : High-Side Output Signal
- LO : Low-Side Output Signal
- C_{SC} : Over Current Detection Input
- /FO : Fault Out Function

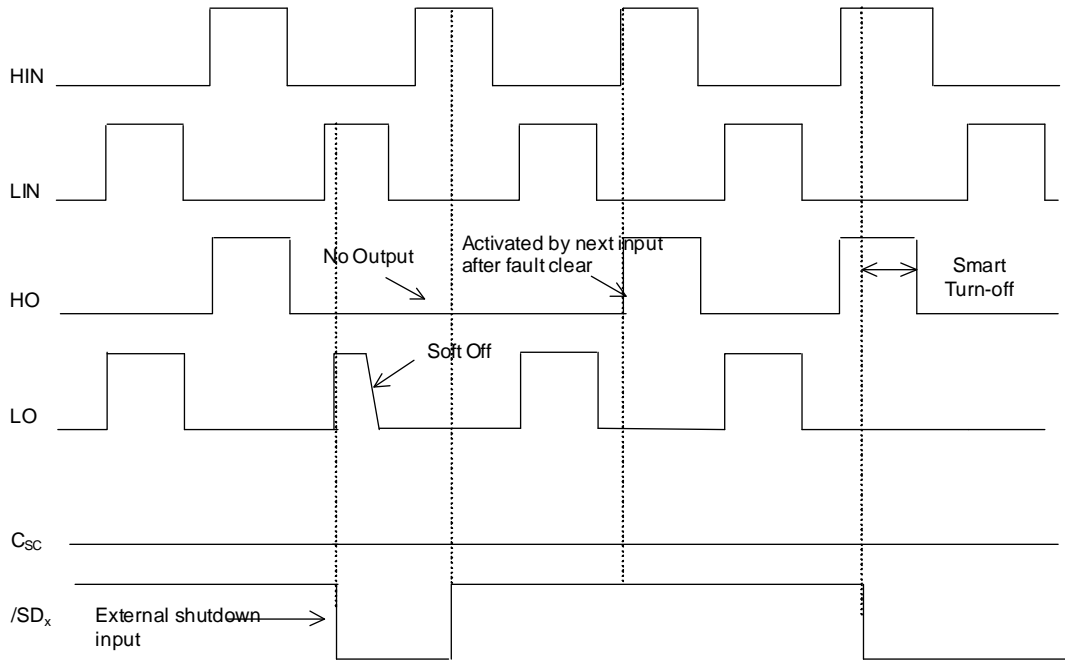

Figure 13. Shutdown Input Function By External Command

HIN : High-side Input Signal
 LIN : Low-side Input Signal
 HO : High-Side Output Signal
 LO : Low-Side Output Signal
 CSC : Over Current Detection Input
 /SD_x : Shutdown Input Function

Input/Output Interface Circuit

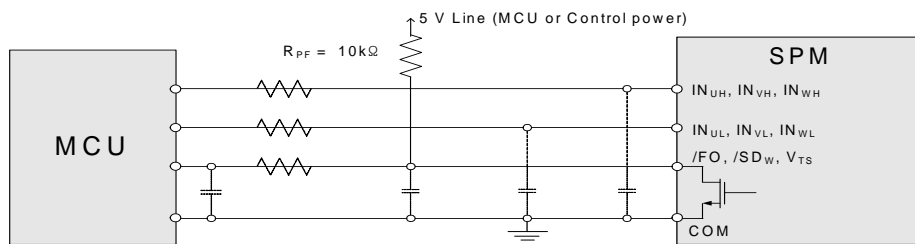
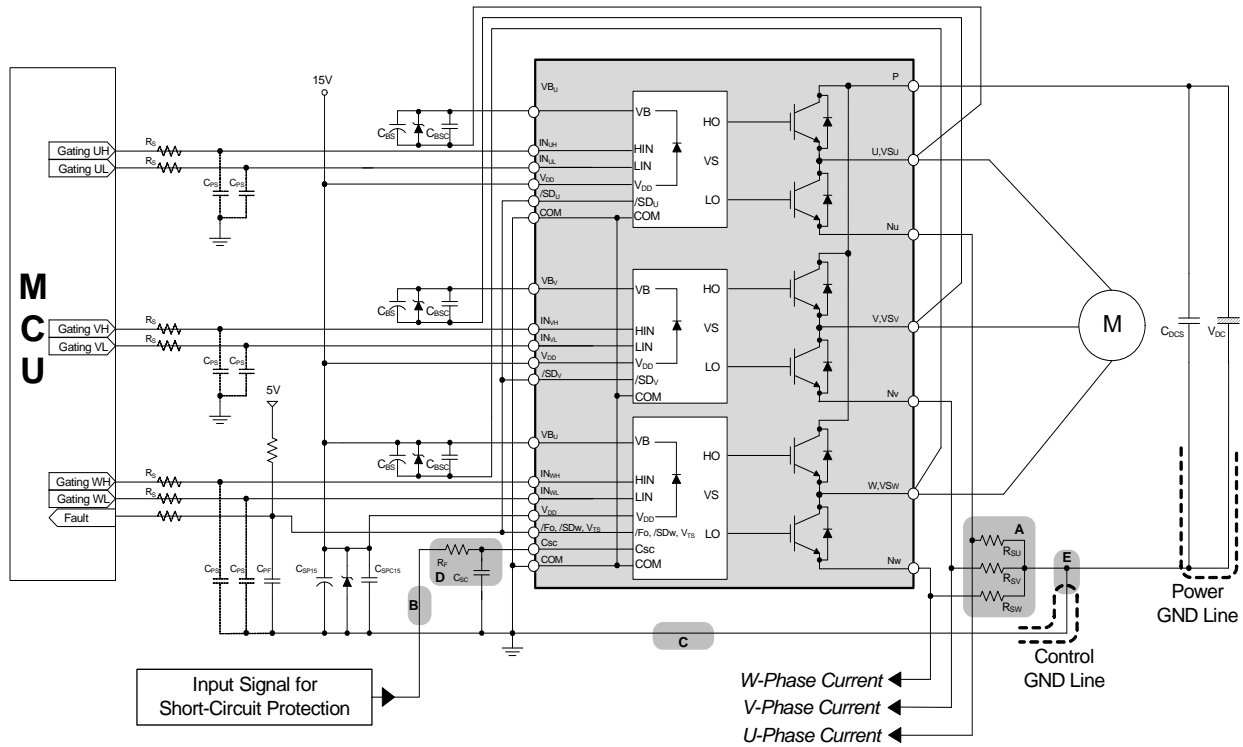

Figure 14. Recommended MCU I/O Interface Circuit

Note:

10. RC coupling at each input (parts shown dotted) might change depending on the PWM control scheme used in the application and the wiring impedance of the application's printed circuit board. The input signal section of the SPM 8 product integrates 5 kΩ (typ.) pull-down resistor. Therefore, when using an external filtering resistor, please pay attention to the signal voltage drop at input terminal.



Note:

11. To avoid malfunction, the wiring of each input should be as short as possible. (less than 2 ~ 3 cm)
12. By virtue of integrating an application specific type of HVIC inside the SPM® 8 product, direct coupling to MCU terminals without any opto-coupler or transformer isolation is possible.
13. /FO is open-drain type. This signal line should be pulled up to the positive side of the MCU or control power supply with a resistor that makes I_{FO} up to 2 mA. *Please refer to Figure 15.*
14. C_{SP15} of around seven times larger than bootstrap capacitor C_{BS} is recommended.
15. Input signal is active-HIGH type. There is a 5 kΩ resistor inside the IC to pull down each input signal line to GND. RC coupling circuits is recommended for the prevention of input signal oscillation. $R_S C_{PS}$ time constant should be selected in the range 50 ~ 150 ns. (Recommended $R_S = 100 \Omega$, $C_{PS} = 1$ nF)
16. Each wiring pattern inductance of A point should be minimized (Recommend less than 10nH). Use the shunt resistor $R_{S(U/V/W)}$ of surface mounted (SMD) type to reduce wiring inductance. To prevent malfunction, wiring of point E should be connected to the terminal of the shunt resistor $R_{S(U/V/W)}$ as close as possible.
17. To prevent errors of the protection function, the wiring of B, C, and D point should be as short as possible.
18. In the short-circuit protection circuit, please select the $R_F C_{SC}$ time constant in the range 1.5 ~ 2 μs. Do enough evaluation on the real system because short-circuit protection time may vary wiring pattern layout and value of the R_F and C_{SC} time constant.
19. The connection between control GND line and power GND line which includes the N_U , N_V , N_W must be connected to only one point. Please do not connect the control GND to the power GND by the broad pattern. Also, the wiring distance between control GND and power GND should be as short as possible.
20. Each capacitor should be mounted as close to the pins of the Motion SPM 8 product as possible.
21. To prevent surge destruction, the wiring between the smoothing capacitor and the P and GND pins should be as short as possible. The use of a high frequency non-inductive capacitor of around 0.1 ~ 0.22 μF between the P and GND pins is recommended.
22. Relays are used at almost every systems of electrical equipments of home appliances. In these cases, there should be sufficient distance between the CPU and the relays.
23. The zener diode or transient voltage suppressor should be adopted for the protection of ICs from the surge destruction between each pair of control supply terminals. (Recommended zener diode is 22 V / 1 W, which has the lower zener impedance characteristic than about 15 Ω)
24. Please choose the electrolytic capacitor with good temperature characteristic in C_{BS} . Also, choose 0.1 ~ 0.2 μF R-category ceramic capacitors with good temperature and frequency characteristics in C_{BSC} .
25. For the detailed information, please refer to the application notes.
26. /FO and /SD must be connected as short as possible. Also, It must always be connected.

Figure 15. Typical Application Circuit

Detailed Package Outline Drawings (FNB81060T3, Long Lead)

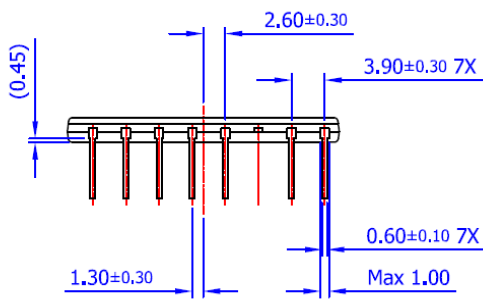
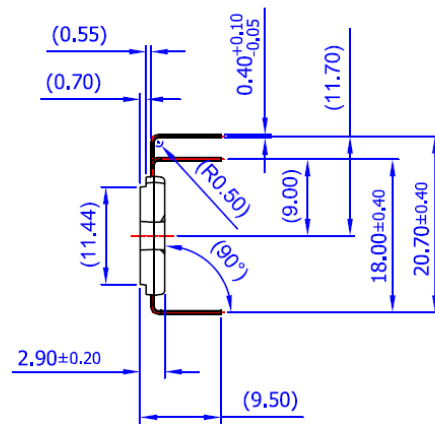
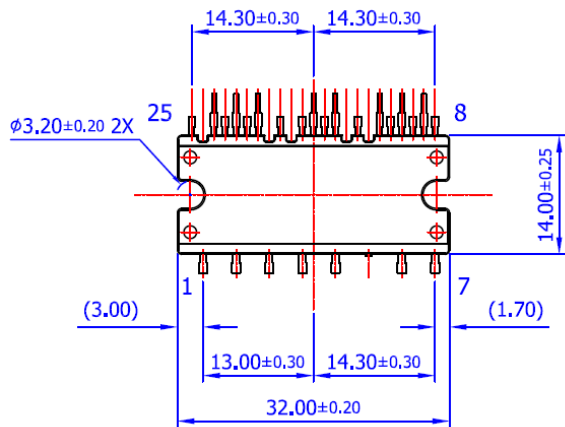
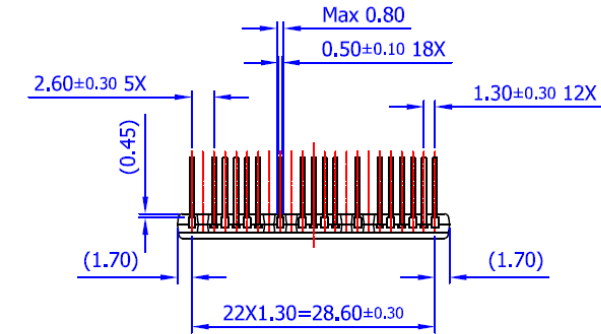





- NOTES: UNLESS OTHERWISE SPECIFIED
 A) NO PACKAGING STANDARD APPLIES
 B) ALL DIMENSIONS ARE IN MILLIMETERS
 C) DIMENSIONS ARE EXCLUSIVE OF BURRS, MOLD FLASH, AND TIE BAR EXTRUSIONS
 D) () IS REFERENCE
 E) DRAWING FILENAME: MOD25DAREV2

Package drawings are provided as a service to customers considering Fairchild components. Drawings may change in any manner without notice. Please note the revision and/or data on the drawing and contact a FairchildSemiconductor representative to verify or obtain the most recent revision. Package specifications do not expand the terms of Fairchild's worldwide therm and conditions, specifically the the warranty therein, which covers Fairchild products.

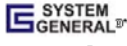

TRADEMARKS

The following includes registered and unregistered trademarks and service marks, owned by Fairchild Semiconductor and/or its global subsidiaries, and is not intended to be an exhaustive list of all such trademarks.

- | | | | |
|--|--|---|---|
| AccuPower™ | F-PFS™ | OPTOPLANAR® |  SYSTEM GENERAL® |
| AttitudeEngine™ | FRFET® |  ® | TinyBoost® |
| Awinda® | Global Power Resource™ | Power Supply WebDesigner™ | TinyBuck® |
| AX-CAP®* | GreenBridge™ | PowerTrench® | TinyCalc™ |
| BitSiC™ | Green FPS™ | PowerXS™ | TinyLogic® |
| Build it Now™ | Green FPS™ e-Series™ | Programmable Active Droop™ | TINYOPTO™ |
| CorePLUS™ | Gmax™ | QFET® | TinyPower™ |
| CorePOWER™ | GTO™ | QS™ | TinyPWM™ |
| CROSSVOLT™ | IntelliMAX™ | Quiet Series™ | TinyWire™ |
| CTL™ | ISOPLANAR™ | RapidConfigure™ | TranSiC™ |
| Current Transfer Logic™ | Making Small Speakers Sound Louder and Better™ |  ™ | TriFault Detect™ |
| DEUXPEED® | MegaBuck™ | Saving our world, 1mW/WkW at a time™ | TRUECURRENT®* |
| Dual Cool™ | MICROCOUPLER™ | SignalWise™ | µSerDes™ |
| EcoSPARK® | MicroFET™ | SmartMax™ |  SerDes™ |
| EfficientMax™ | MicroPak™ | SMART START™ | UHC® |
| ESBC™ | MicroPak2™ | Solutions for Your Success™ | Ultra FRFET™ |
|  Fairchild® | MillerDrive™ | SPM® | UniFET™ |
| Fairchild Semiconductor® | MotionMax™ | STEALTH™ | VCX™ |
| FACT Quiet Series™ | MotionGrid® | SuperFET® | VisualMax™ |
| FACT® | MTI® | SuperSOT™-3 | VoltagePlus™ |
| FastvCore™ | MTX® | SuperSOT™-6 | XS™ |
| FETBench™ | MVN® | SuperSOT™-8 | Xsens™ |
| FPS™ | mWSaver® | SupreMOS® | 仙童® |
| | OptoHiT™ | SyncFET™ | |
| | OPTOLOGIC® | Sync-Lock™ | |

* Trademarks of System General Corporation, used under license by Fairchild Semiconductor.

DISCLAIMER

FAIRCHILD SEMICONDUCTOR RESERVES THE RIGHT TO MAKE CHANGES WITHOUT FURTHER NOTICE TO ANY PRODUCTS HEREIN TO IMPROVE RELIABILITY, FUNCTION, OR DESIGN. TO OBTAIN THE LATEST, MOST UP-TO-DATE DATASHEET AND PRODUCT INFORMATION, VISIT OUR WEBSITE AT [HTTP://WWW.FAIRCHILDSEMI.COM](http://www.fairchildsemi.com). FAIRCHILD DOES NOT ASSUME ANY LIABILITY ARISING OUT OF THE APPLICATION OR USE OF ANY PRODUCT OR CIRCUIT DESCRIBED HEREIN; NEITHER DOES IT CONVEY ANY LICENSE UNDER ITS PATENT RIGHTS, NOR THE RIGHTS OF OTHERS. THESE SPECIFICATIONS DO NOT EXPAND THE TERMS OF FAIRCHILD'S WORLDWIDE TERMS AND CONDITIONS, SPECIFICALLY THE WARRANTY THEREIN, WHICH COVERS THESE PRODUCTS.

AUTHORIZED USE

Unless otherwise specified in this data sheet, this product is a standard commercial product and is not intended for use in applications that require extraordinary levels of quality and reliability. This product may not be used in the following applications, unless specifically approved in writing by a Fairchild officer: (1) automotive or other transportation, (2) military/aerospace, (3) any safety critical application – including life critical medical equipment – where the failure of the Fairchild product reasonably would be expected to result in personal injury, death or property damage. Customer's use of this product is subject to agreement of this Authorized Use policy. In the event of an unauthorized use of Fairchild's product, Fairchild accepts no liability in the event of product failure. In other respects, this product shall be subject to Fairchild's Worldwide Terms and Conditions of Sale, unless a separate agreement has been signed by both Parties.

ANTI-COUNTERFEITING POLICY

Fairchild Semiconductor Corporation's Anti-Counterfeiting Policy. Fairchild's Anti-Counterfeiting Policy is also stated on our external website, www.fairchildsemi.com, under Terms of Use

Counterfeiting of semiconductor parts is a growing problem in the industry. All manufacturers of semiconductor products are experiencing counterfeiting of their parts. Customers who inadvertently purchase counterfeit parts experience many problems such as loss of brand reputation, substandard performance, failed applications, and increased cost of production and manufacturing delays. Fairchild is taking strong measures to protect ourselves and our customers from the proliferation of counterfeit parts. Fairchild strongly encourages customers to purchase Fairchild parts either directly from Fairchild or from Authorized Fairchild Distributors who are listed by country on our web page cited above. Products customers buy either from Fairchild directly or from Authorized Fairchild Distributors are genuine parts, have full traceability, meet Fairchild's quality standards for handling and storage and provide access to Fairchild's full range of up-to-date technical and product information. Fairchild and our Authorized Distributors will stand behind all warranties and will appropriately address any warranty issues that may arise. Fairchild will not provide any warranty coverage or other assistance for parts bought from Unauthorized Sources. Fairchild is committed to combat this global problem and encourage our customers to do their part in stopping this practice by buying direct or from authorized distributors.

PRODUCT STATUS DEFINITIONS

Definition of Terms

Datasheet Identification	Product Status	Definition
Advance Information	Formative / In Design	Datasheet contains the design specifications for product development. Specifications may change in any manner without notice.
Preliminary	First Production	Datasheet contains preliminary data; supplementary data will be published at a later date. Fairchild Semiconductor reserves the right to make changes at any time without notice to improve design.
No Identification Needed	Full Production	Datasheet contains final specifications. Fairchild Semiconductor reserves the right to make changes at any time without notice to improve the design.
Obsolete	Not In Production	Datasheet contains specifications on a product that is discontinued by Fairchild Semiconductor. The datasheet is for reference information only.

Rev. I77