

FNK N-Channel Enhancement Mode Power MOSFET

Description

The FNK6578D uses advanced trench technology and design to provide excellent $R_{DS(ON)}$ with low gate charge. It can be used in a wide variety of applications.

General Features

- $V_{DS} = 65V, I_D = 78A$
 $R_{DS(ON)} < 8.2m\Omega @ V_{GS}=10V$ (Typ:6.7m Ω)
- Special process technology for high ESD capability
- High density cell design for ultra low R_{dson}
- Fully characterized avalanche voltage and current
- Good stability and uniformity with high E_{AS}
- Excellent package for good heat dissipation

Application

- Power switching application
- Hard switched and High frequency circuits
- Uninterruptible power supply

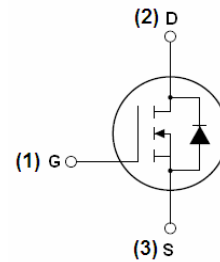

Schematic diagram

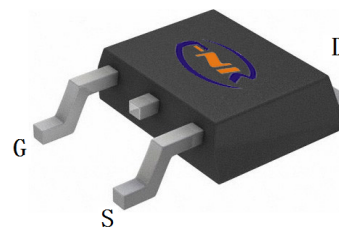

To-263 Top View

Package Marking and Ordering Information

| Device Marking | Device | Device Package | Reel Size | Tape width | Quantity |
|----------------|----------|----------------|-----------|------------|----------|
| FNK6578D | FNK6578D | TO-263 | - | - | - |

Absolute Maximum Ratings ($T_C=25^\circ C$ unless otherwise noted)

| Parameter | Symbol | Limit | Unit |
|---|--------------------|----------|---------------|
| Drain-Source Voltage | V_{DS} | 65 | V |
| Gate-Source Voltage | V_{GS} | ± 20 | V |
| Drain Current-Continuous | I_D | 78 | A |
| Drain Current-Continuous($T_C=100^\circ C$) | $I_D(100^\circ C)$ | 52 | A |
| Pulsed Drain Current | I_{DM} | 312 | A |
| Maximum Power Dissipation | P_D | 130 | W |
| Derating factor | | 0.86 | W/ $^\circ C$ |

| Parameter | Symbol | Limit | Unit |
|---|----------------|------------|------|
| Single pulse avalanche energy ^(Note 5) | E_{AS} | 158 | mJ |
| Operating Junction and Storage Temperature Range | T_J, T_{STG} | -55 To 175 | °C |

Thermal Characteristic

| | | | |
|--|-----------------|------|------|
| Thermal Resistance, Junction-to-Case ^(Note 2) | $R_{\theta Jc}$ | 1.15 | °C/W |
|--|-----------------|------|------|

Electrical Characteristics (TC=25°C unless otherwise noted)

| Parameter | Symbol | Condition | Min | Typ | Max | Unit |
|--|--------------|---|-----|------|------|------|
| Off Characteristics | | | | | | |
| Drain-Source Breakdown Voltage | BV_{DSS} | $V_{GS}=0V, I_D=250\mu A$ | 65 | - | - | V |
| Zero Gate Voltage Drain Current | I_{DSS} | $V_{DS}=65V, V_{GS}=0V$ | - | - | 1 | μA |
| Gate-Body Leakage Current | I_{GSS} | $V_{GS}=\pm 20V, V_{DS}=0V$ | - | - | ±100 | nA |
| On Characteristics ^(Note 3) | | | | | | |
| Gate Threshold Voltage | $V_{GS(th)}$ | $V_{DS}=V_{GS}, I_D=250\mu A$ | 2 | 2.8 | 4 | V |
| Drain-Source On-State Resistance | $R_{DS(ON)}$ | $V_{GS}=10V, I_D=30A$ | - | 6.7 | 8.2 | mΩ |
| Forward Transconductance | g_{FS} | $V_{DS}=10V, I_D=20A$ | 20 | - | - | S |
| Dynamic Characteristics ^(Note 4) | | | | | | |
| Input Capacitance | C_{iss} | $V_{DS}=25V, V_{GS}=0V,$ $F=1.0MHz$ | - | 3140 | - | PF |
| Output Capacitance | C_{oss} | | - | 360 | - | PF |
| Reverse Transfer Capacitance | C_{rss} | | - | 280 | - | PF |
| Switching Characteristics ^(Note 4) | | | | | | |
| Turn-on Delay Time | $t_{d(on)}$ | $V_{DD}=30V, I_D=30A$ $V_{GS}=10V, R_{GEN}=6\Omega$ | - | 15 | - | nS |
| Turn-on Rise Time | t_r | | - | 94 | - | nS |
| Turn-Off Delay Time | $t_{d(off)}$ | | - | 46 | - | nS |
| Turn-Off Fall Time | t_f | | - | 32 | - | nS |
| Total Gate Charge | Q_g | $V_{DS}=30V, I_D=20A,$ $V_{GS}=10V$ | - | 35 | - | nC |
| Gate-Source Charge | Q_{gs} | | - | 11 | - | nC |
| Gate-Drain Charge | Q_{gd} | | - | 9 | - | nC |
| Drain-Source Diode Characteristics | | | | | | |
| Diode Forward Voltage ^(Note 3) | V_{SD} | $V_{GS}=0V, I_S=90A$ | - | - | 1.2 | V |
| Diode Forward Current ^(Note 2) | I_S | - | - | - | 90 | A |
| Reverse Recovery Time | t_{rr} | $T_J = 25^\circ C, I_F = 90A$ $di/dt = 100A/\mu s$ ^(Note 3) | - | 78 | - | nS |
| Reverse Recovery Charge | Q_{rr} | | - | 51 | - | nC |

Notes:

1. Repetitive Rating: Pulse width limited by maximum junction temperature.
2. Surface Mounted on FR4 Board, $t \leq 10$ sec.
3. Pulse Test: Pulse Width $\leq 300\mu s$, Duty Cycle $\leq 2\%$.
4. Guaranteed by design, not subject to production
5. E_{AS} condition: $T_J=25^\circ C, V_{DD}=30V, V_G=10V, L=0.5mH, R_g=25\Omega$

Test Circuit

1) E_{AS} test Circuit



2) Gate charge test Circuit

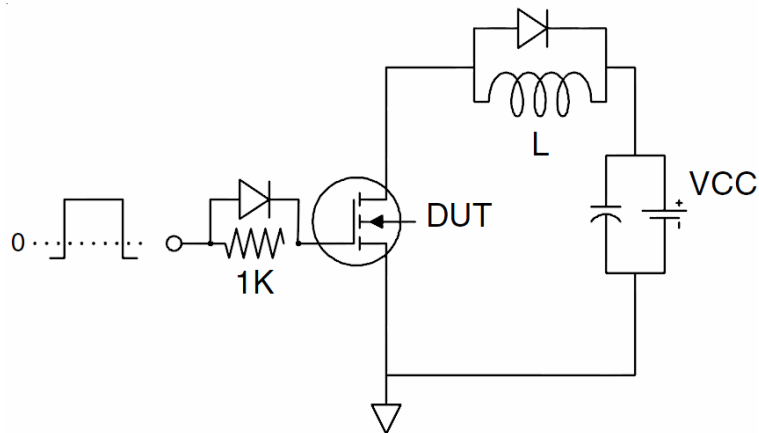

3) Switch Time Test Circuit

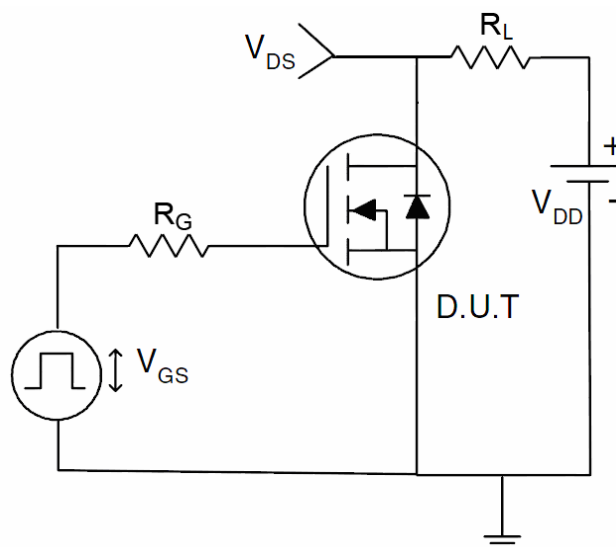

Typical Electrical and Thermal Characteristics (Curves)

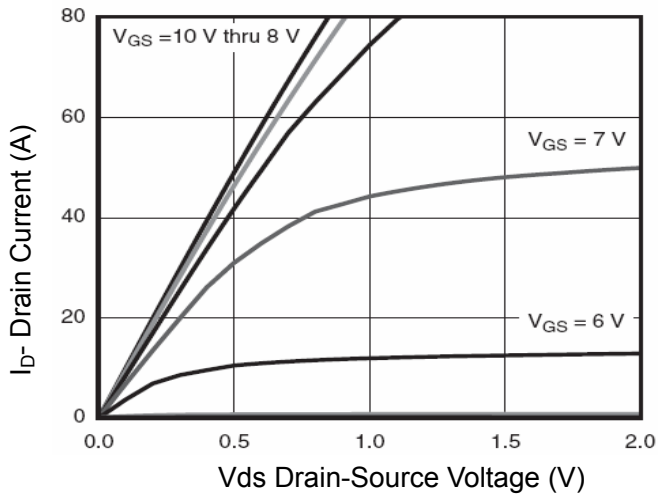

Figure 1 Output Characteristics

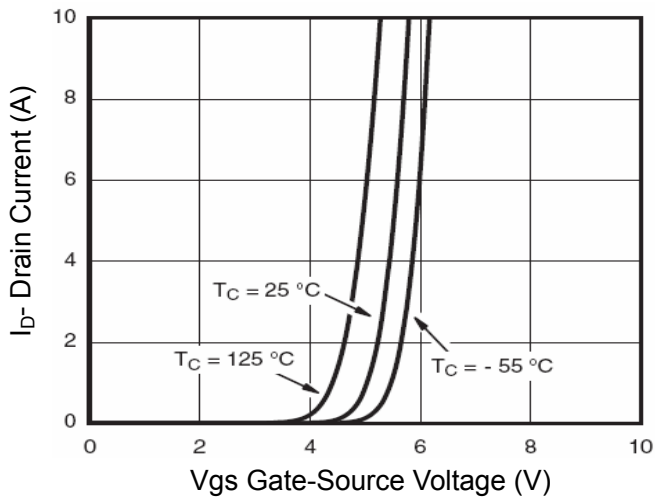

Figure 2 Transfer Characteristics

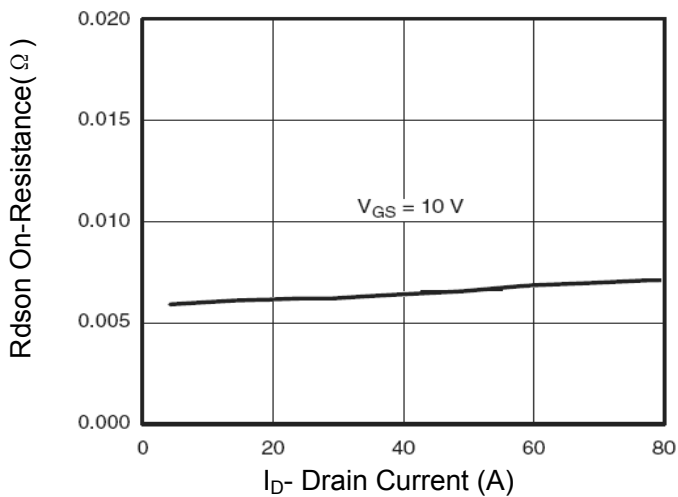

Figure 3 Rdson- Drain Current

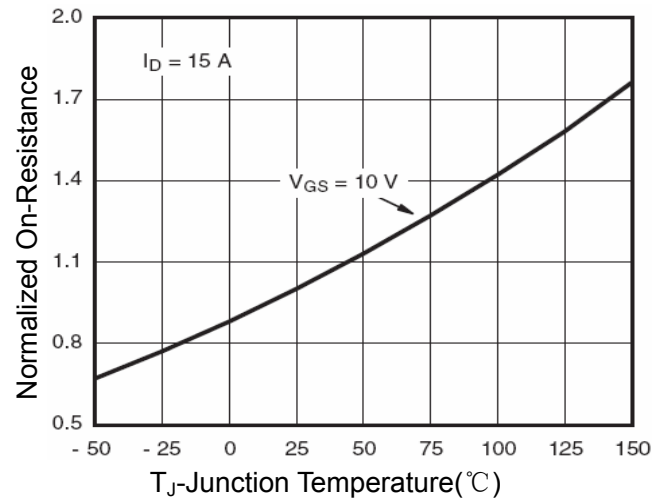

Figure 4 Rdson-Junction Temperature

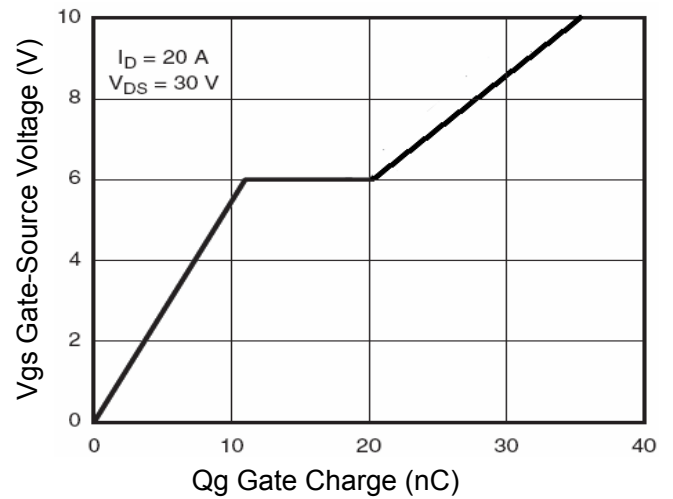

Figure 5 Gate Charge

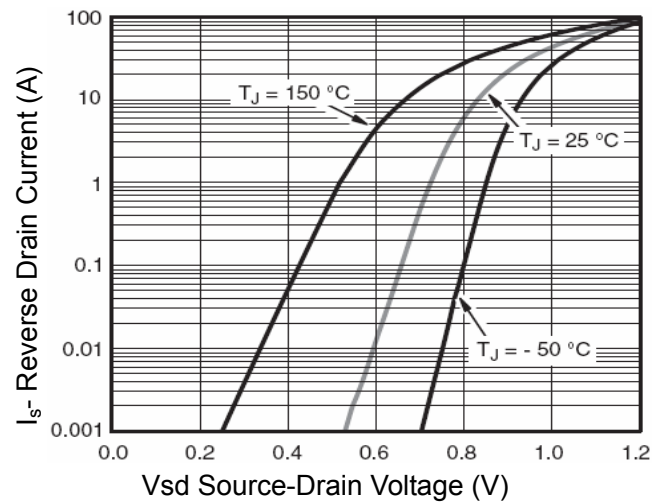

Figure 6 Source- Drain Diode Forward

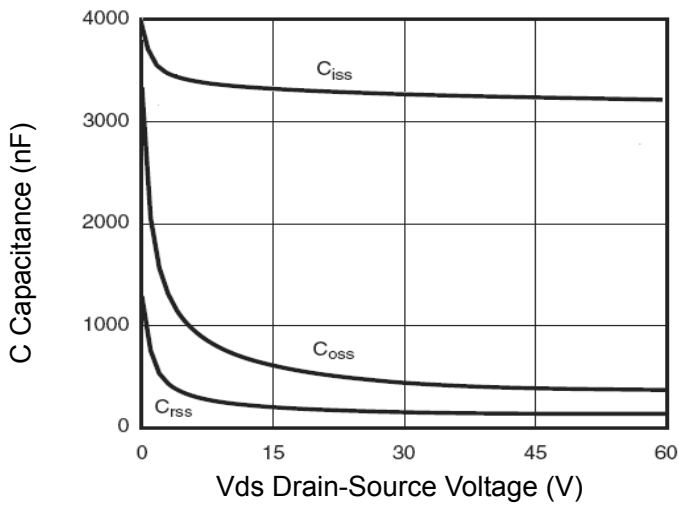

Figure 7 Capacitance vs Vds

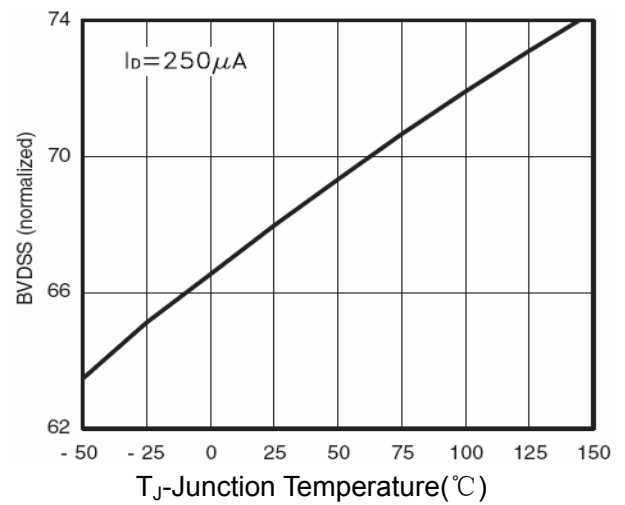

Figure 9 BV_{DSS} vs Junction Temperature

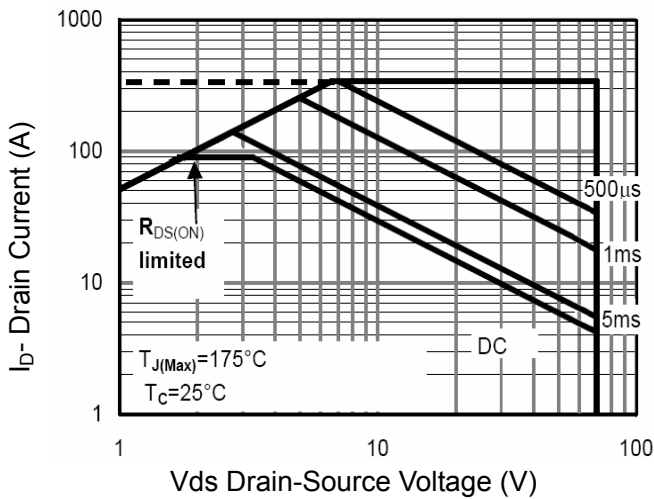

Figure 8 Safe Operation Area

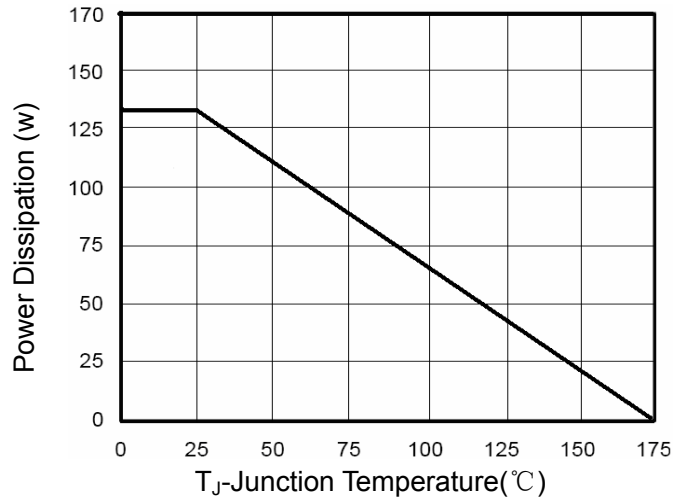

Figure 10 Power De-rating

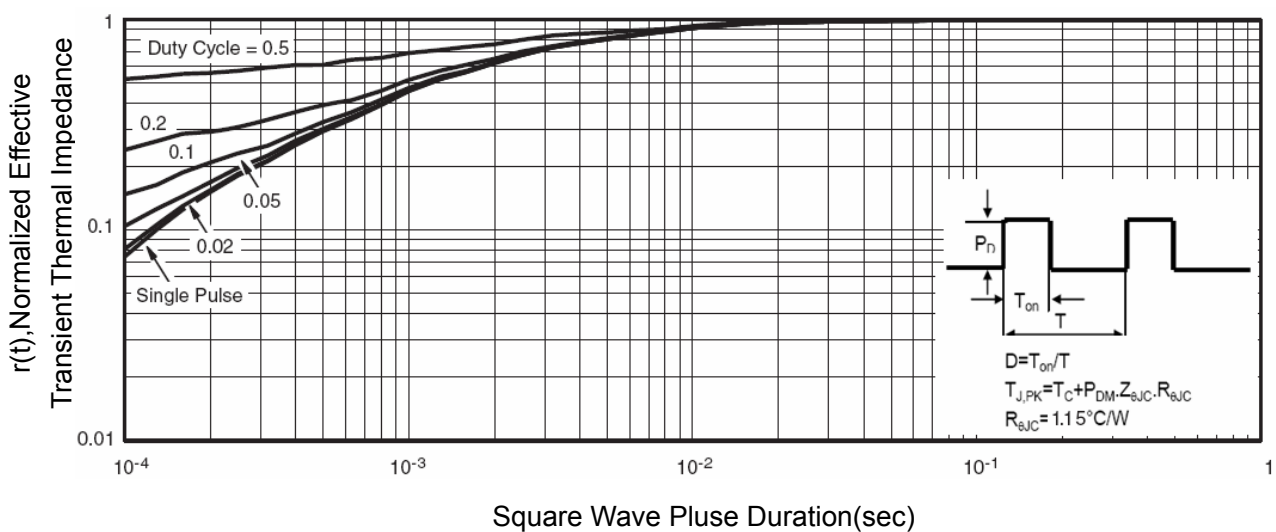
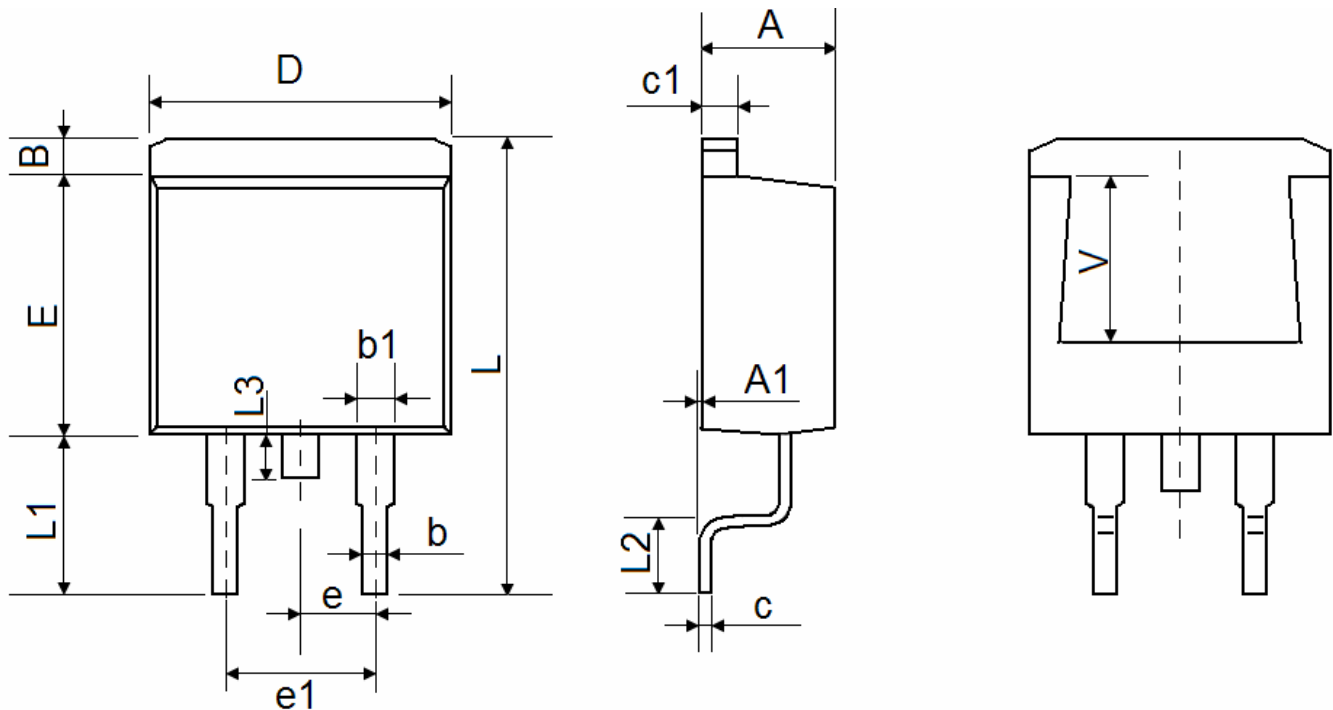

Figure 11 Normalized Maximum Transient Thermal Impedance

TO-263 Package Information



| Symbol | Dimensions In Millimeters | | Dimensions In Inches | |
|--------|---------------------------|--------|----------------------|-------|
| | Min. | Max. | Min. | Max. |
| A | 4.470 | 4.670 | 0.176 | 0.184 |
| A1 | 0.000 | 0.150 | 0.000 | 0.006 |
| B | 1.170 | 1.370 | 0.046 | 0.054 |
| b | 0.710 | 0.910 | 0.028 | 0.036 |
| b1 | 1.170 | 1.370 | 0.046 | 0.054 |
| c | 0.310 | 0.530 | 0.012 | 0.021 |
| c1 | 1.170 | 1.370 | 0.046 | 0.054 |
| D | 10.010 | 10.310 | 0.394 | 0.406 |
| E | 8.500 | 8.900 | 0.335 | 0.350 |
| e | 2.540 TYP. | | 0.100 TYP. | |
| e1 | 4.980 | 5.180 | 0.196 | 0.204 |
| L | 15.050 | 15.450 | 0.593 | 0.608 |
| L1 | 5.080 | 5.480 | 0.200 | 0.216 |
| L2 | 2.340 | 2.740 | 0.092 | 0.108 |
| L3 | 1.300 | 1.700 | 0.051 | 0.067 |
| V | 5.600 REF | | 0.220 REF | |

Disclaimer:

- FNK reserves the right to make changes to the information herein for the improvement of the design and performance without further notice! Customers should obtain the latest relevant information before placing orders and should verify that such information is complete and current.
- All semiconductor products malfunction or fail with some probability under special conditions. When using FNK products in system design or complete machine manufacturing, it is the responsibility of the buyer to comply with the safety standards strictly and take essential measures to avoid situations in which a malfunction or failure of such Silan products could cause loss of body injury or damage to property.
- FNK will supply the best possible product for customers!