

N-Channel Trench Power MOSFET

General Description

The FNK6585 is N-channel MOS Field Effect Transistor designed for high current switching applications. Rugged EAS capability and ultra low $R_{DS(ON)}$ is suitable for PWM, load switching especially for E-Bike controller applications.

Features

- $V_{DS}=65V$; $I_D=88A$ @ $V_{GS}=10V$;
 $R_{DS(ON)}<7.45m\Omega$ @ $V_{GS}=10V$
- Special Designed for E-Bike Controller Application
- Ultra Low On-Resistance
- High UIS and UIS 100% Test

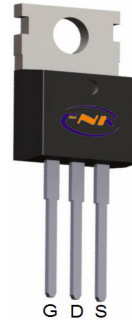

To-220 Top View

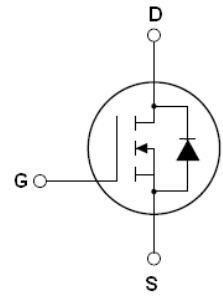

Schematic Diagram

$$V_{DS} = 65 V$$

$$I_D = 88 A$$

$$R_{DS(ON)} = 6.2 m\Omega$$



Package Marking and Ordering Information

Device Marking	Device	Device Package	Reel Size	Tape width	Quantity
FNK6585	FNK6585	TO-220	-	-	-

Table 1. Absolute Maximum Ratings (TA=25°C)

Symbol	Parameter	Value	Unit
V_{DS}	Drain-Source Voltage ($V_{GS}=0V$)	65	V
V_{GS}	Gate-Source Voltage ($V_{DS}=0V$)	± 25	V
$I_{D(DC)}$	Drain Current (DC) at $T_c=25^\circ C$	88	A
$I_{D(DC)}$	Drain Current (DC) at $T_c=100^\circ C$	56	A
$I_{DM(pluse)}$	Drain Current-Continuous@ Current-Pulsed (Note 1)	345	A
dv/dt	Peak Diode Recovery Voltage	30	V/ns
P_D	Maximum Power Dissipation($T_c=25^\circ C$)	139	W
	Derating Factor	0.93	W/°C
EAS	Single Pulse Avalanche Energy (Note 2)	550	mJ
T_J, T_{STG}	Operating Junction and Storage Temperature Range	-55 To 175	°C

Notes 1.Repetitive Rating: Pulse width limited by maximum junction temperature

2.EAS condition: $T_J=25^\circ C, V_{DD}=40V, V_G=10V, R_G=25\Omega$

Table 2. Thermal Characteristic

Symbol	Parameter	Value	Unit
R _{θJC}	Thermal Resistance, Junction-to-Case	1.08	°C/W

Table 3. Electrical Characteristics (TA=25°C unless otherwise noted)

Symbol	Parameter	Conditions	Min	Typ	Max	Unit
On/Off States						
BV _{DSS}	Drain-Source Breakdown Voltage	V _{GS} =0V, I _D =250μA	65			V
I _{DSS}	Zero Gate Voltage Drain Current(Tc=25°C)	V _{DS} =65V, V _{GS} =0V			1	μA
I _{DSS}	Zero Gate Voltage Drain Current(Tc=125°C)	V _{DS} =65V, V _{GS} =0V			10	μA
I _{GSS}	Gate-Body Leakage Current	V _{GS} =±20V, V _{DS} =0V			±100	nA
V _{GS(th)}	Gate Threshold Voltage	V _{DS} =V _{GS} , I _D =250μA	2		4	V
R _{DS(ON)}	Drain-Source On-State Resistance	V _{GS} =10V, I _D =40A		6.2	7.45	mΩ
Dynamic Characteristics						
g _{FS}	Forward Transconductance	V _{DS} =25V, I _D =40A	110			S
C _{iss}	Input Capacitance	V _{DS} =25V, V _{GS} =0V, f=1.0MHz		5050		PF
C _{oss}	Output Capacitance			460		PF
C _{rss}	Reverse Transfer Capacitance			160		PF
Q _g	Total Gate Charge	V _{DS} =50V, I _D =40A, V _{GS} =10V		106		nC
Q _{gs}	Gate-Source Charge			19		nC
Q _{gd}	Gate-Drain Charge			47.9		nC
Switching Times						
t _{d(on)}	Turn-on Delay Time	V _{DD} =30V, I _D =2A, R _L =15Ω V _{GS} =10V, R _G =2.5Ω		15		nS
t _r	Turn-on Rise Time			18		nS
t _{d(off)}	Turn-Off Delay Time			31		nS
t _f	Turn-Off Fall Time			38		nS
Source-Drain Diode Characteristics						
I _{SD}	Source-drain Current(Body Diode)			88		A
I _{SDM}	Pulsed Source-Drain Current(Body Diode)			345		A
V _{SD}	Forward On Voltage ^(Note 1)	T _J =25°C, I _{SD} =40A, V _{GS} =0V		0.8	0.95	V
t _{rr}	Reverse Recovery Time ^(Note 1)	T _J =25°C, I _F =75A di/dt=100A/μs		56		nS
Q _{rr}	Reverse Recovery Charge ^(Note 1)			113		nC
t _{on}	Forward Turn-on Time	Intrinsic turn-on time is negligible(turn-on is dominated by L _S +L _D)				

Notes 1. Pulse Test: Pulse Width ≤ 300μs, Duty Cycle ≤ 1.5%, R_G=25Ω, Starting T_J=25°C

Test Circuit

1) E_{AS} Test Circuits

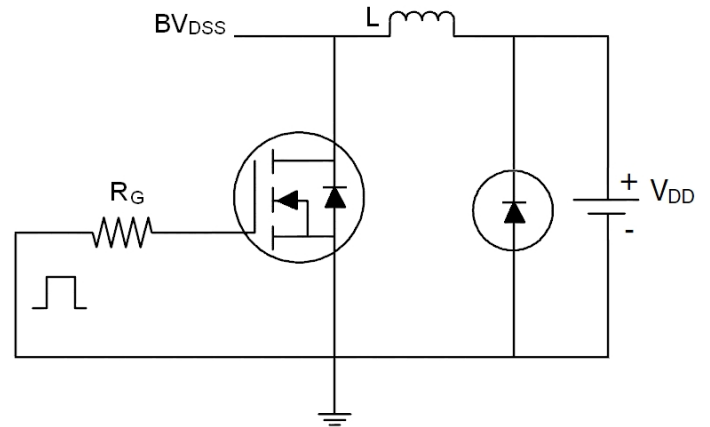
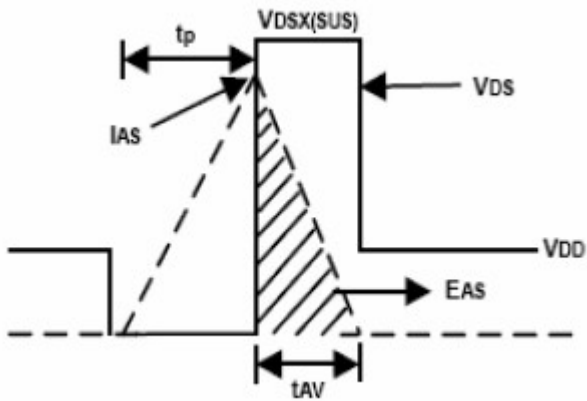

2) Gate Charge Test Circuit:

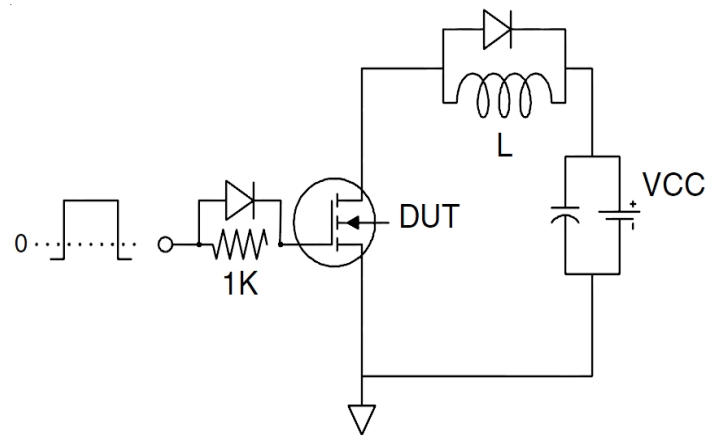
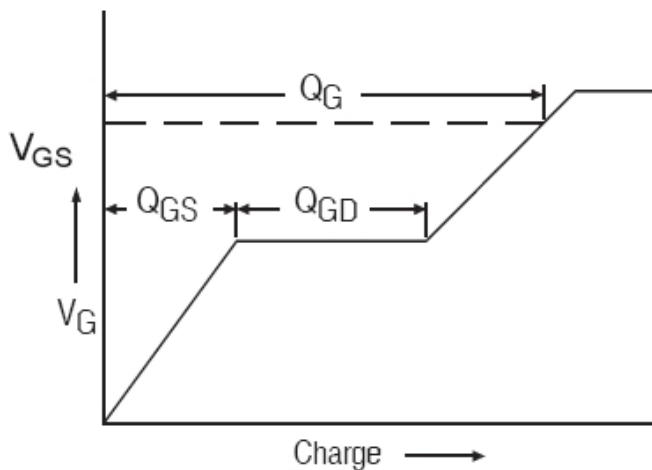

3) Switch Time Test Circuit:

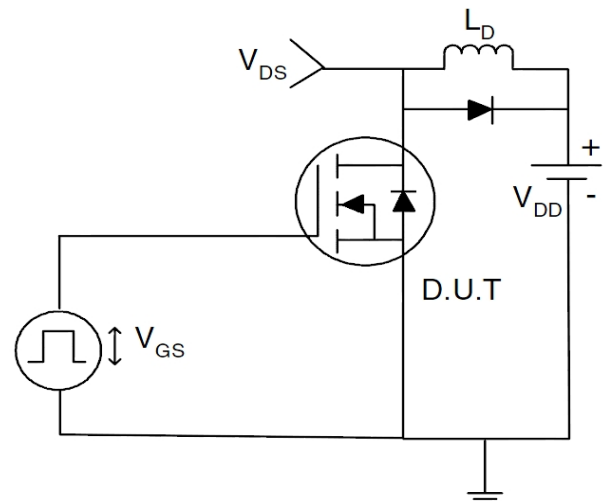
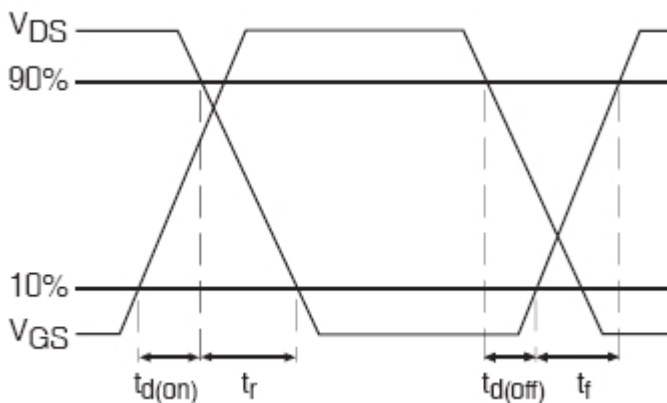

TYPICAL ELECTRICAL AND THERMAL CHARACTERISTICS (Curves)

Figure1. Output Characteristics

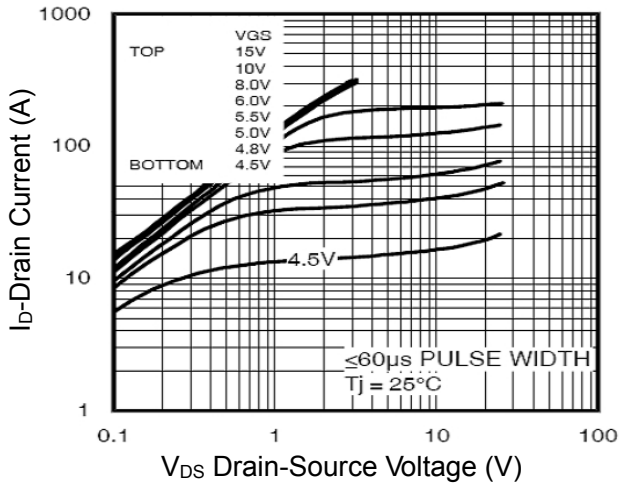

Figure2. Transfer Characteristics

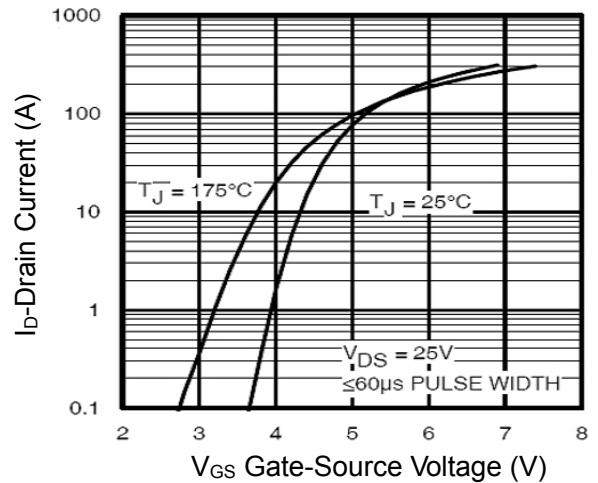

Figure3. Rdson Vs Drain Current

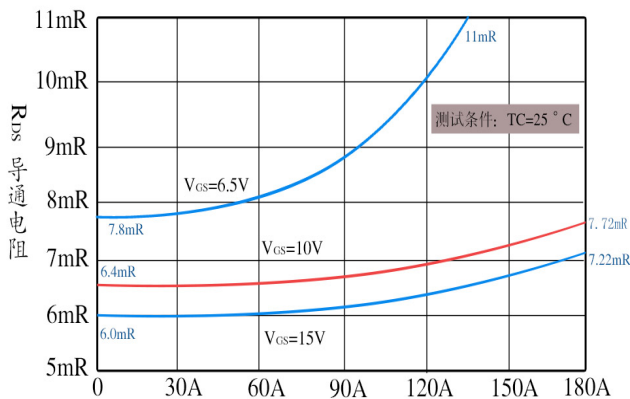

Figure4. Rdson Vs Junction Temperature

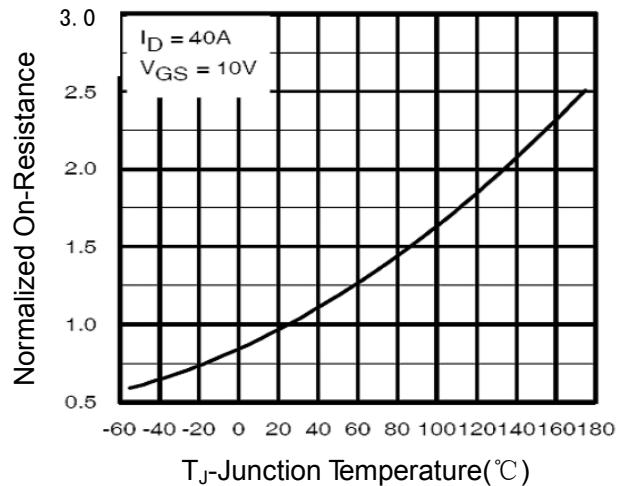

Figure5. Gate Charge

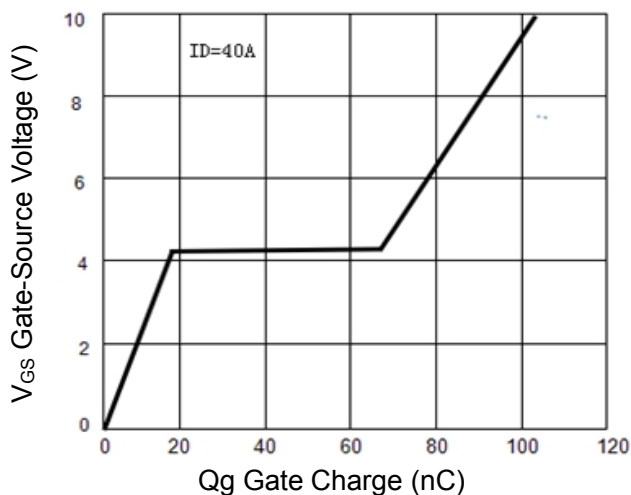

Figure6. Source- Drain Diode Forward

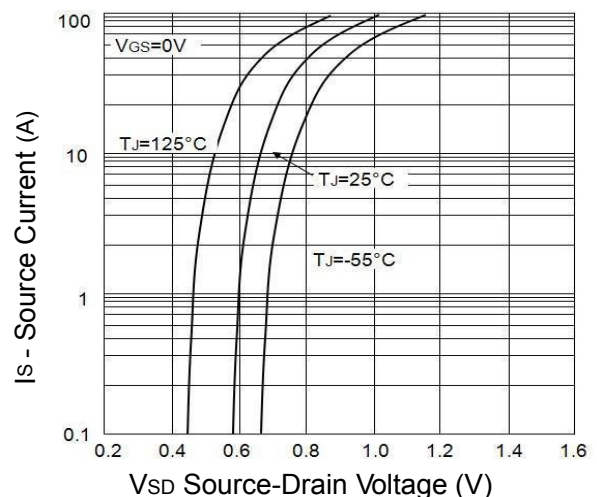
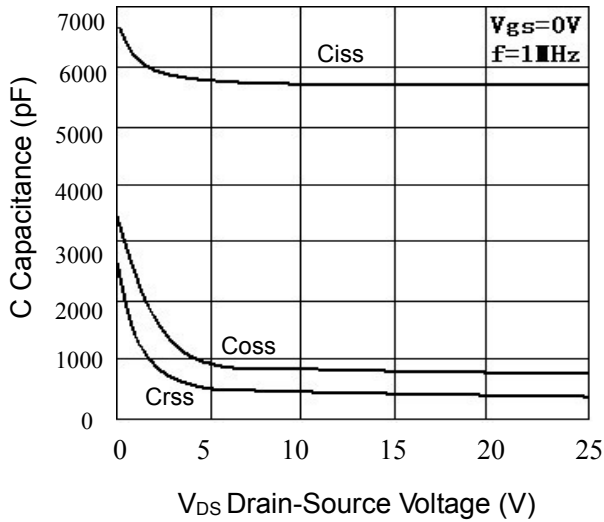
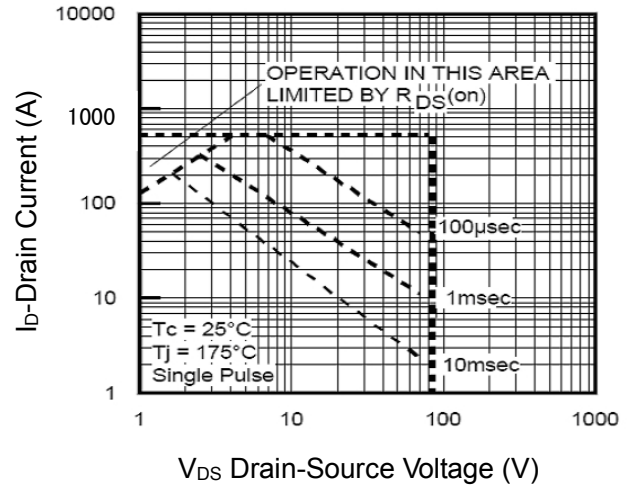
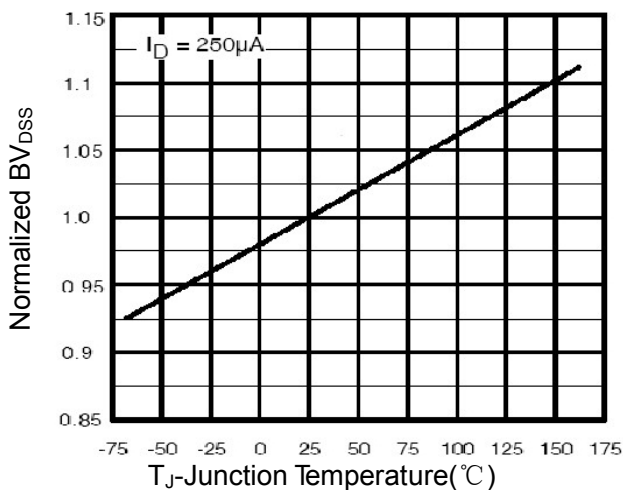
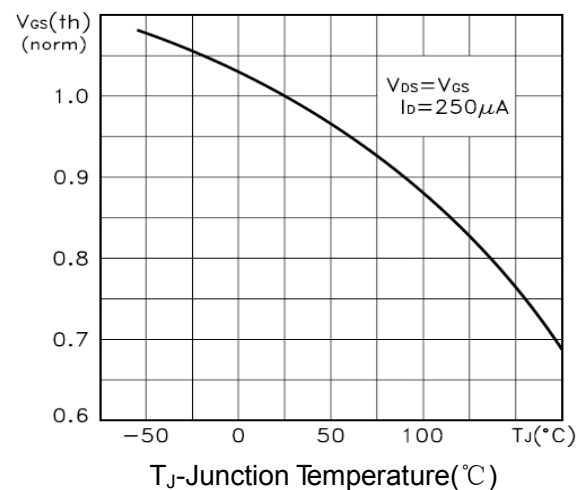
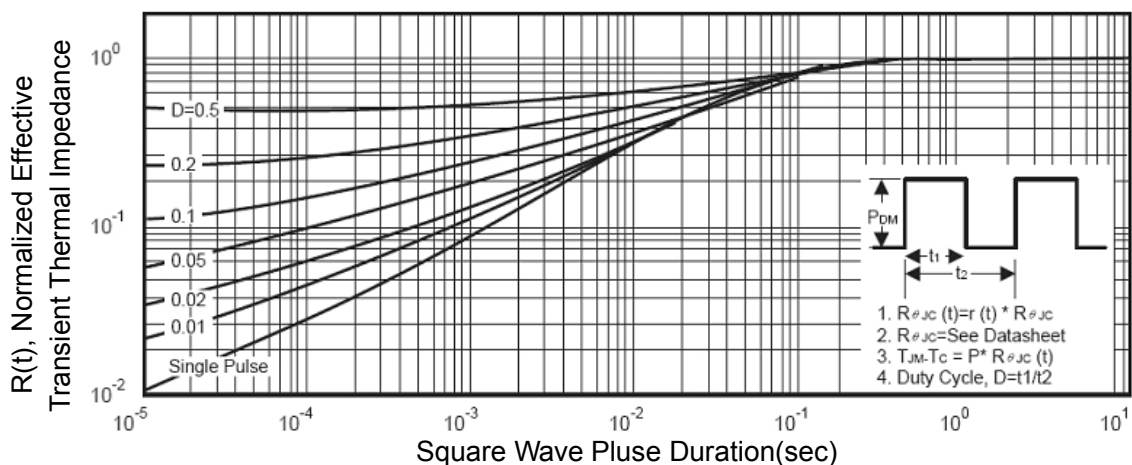
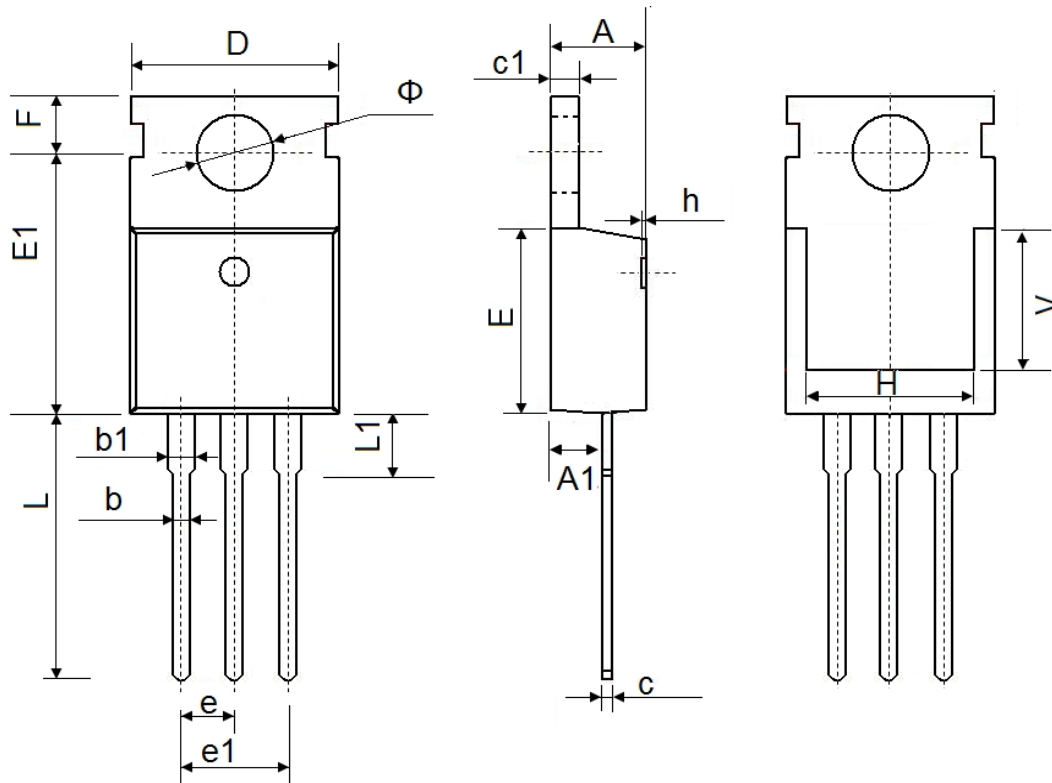

Figure7. Capacitance vs Vds

Figure8. Safe Operation Area

Figure9. BVDS vs Junction Temperature

Figure10. VGS(th) vs Junction Temperature

Figure11. Normalized Maximum Transient Thermal Impedance

TO-220 Package Information



Symbol	Dimensions In Millimeters		Dimensions In Inches	
	Min.	Max.	Min.	Max.
A	4.400	4.600	0.173	0.181
A1	2.250	2.550	0.089	0.100
b	0.710	0.910	0.028	0.036
b1	1.170	1.370	0.046	0.054
c	0.330	0.650	0.013	0.026
c1	1.200	1.400	0.047	0.055
D	9.910	10.250	0.390	0.404
E	8.9500	9.750	0.352	0.384
E1	12.650	12.950	0.498	0.510
e	2.540 TYP.		0.100TYP.	
e1	4.980	5.180	0.196	0.204
F	2.650	2.950	0.104	0.116
H	7.900	8.100	0.311	0.319
h	0.000	0.300	0.000	0.012
L	12.900	13.400	0.508	0.528
L1	2.850	3.250	0.112	0.128
V	7.500 REF.		0.295 REF.	
Φ	3.400	3.800	0.134	0.150