

## Non-Synchronous PWM Boost Controller



### General Description

The FP5207 is boost topology switching regulator for wide operating voltage applications. It provides built-in gate driver pin for driving external N-MOSFET. The non-inverting input of error amplifier connects to a 1.2V precision reference voltage. It has programmable switching frequency set by external resistor, and programmable inductor peak current limit connects a resistor from CS to GND. Current mode control and external compensation network make is easy and flexible to stabilize the system.

The FP5207 is available in the small footprint SOP-8L(EP) package to fit in space-saving PCB layout for application fields.

### Features

- Start-up Voltage: 2.8V
- Wide Supply Voltage Operating Range: 5V to 24V
- Precision Feedback Reference Voltage: 1.2V ( $\pm 2\%$ )
- Shutdown Current:  $< 3\mu\text{A}$
- Programmable Switching Frequency: 100KHz~1000KHz
- Input Under Voltage Protection(UVP)
- Switching MOSFET Over Current Protection (OCP)
- Over Temperature Protection (OTP)
- Package: SOP-8L(EP)

### Applications

- Chargers
- LCD Displays
- Handheld Devices
- Portable Products
- Power Bank

## Typical Application Circuit

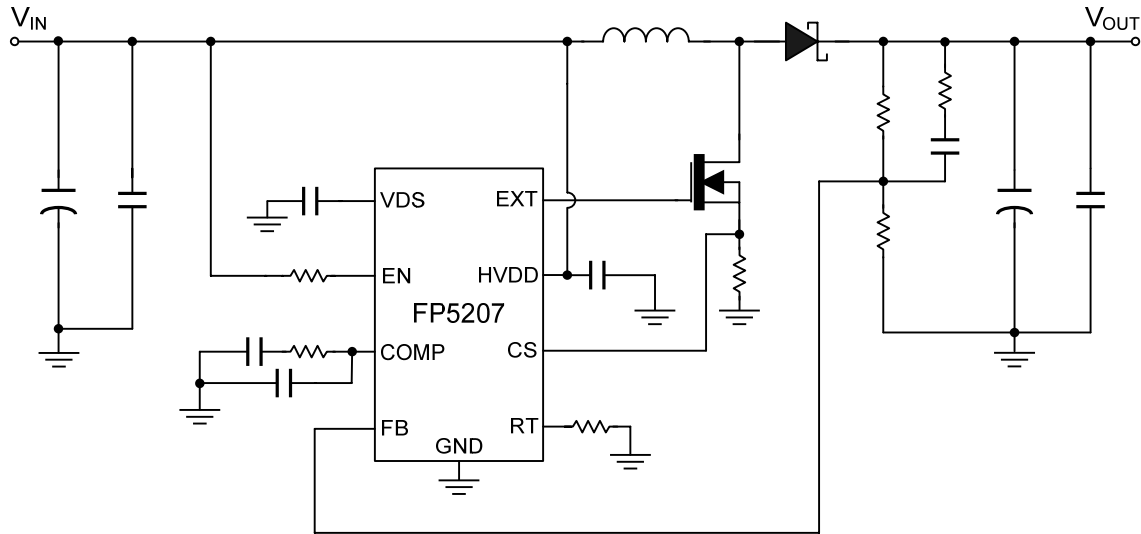

## Function Block Diagram

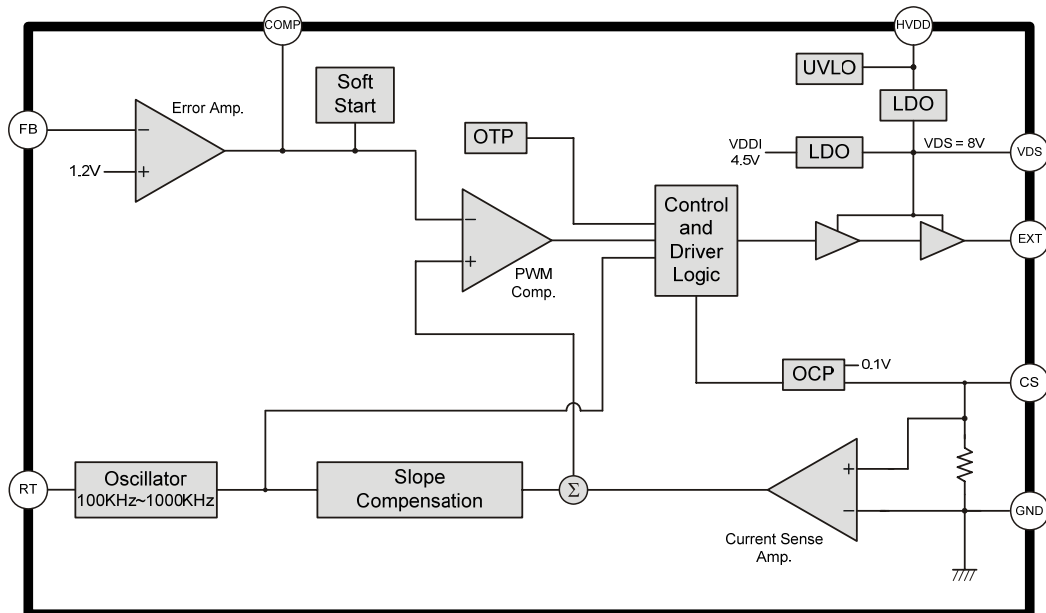

This datasheet contains new product information. Feeling Technology reserves the rights to modify the product specification without notice. No liability is assumed as a result of the use of this product. No rights under any patent accompany the sales of the product.

## Pin Descriptions

### SOP-8L (EP)

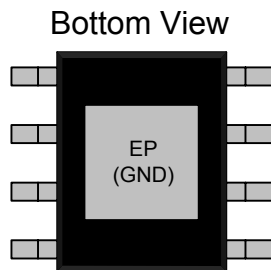
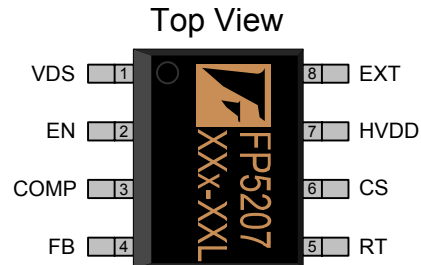

Name	No.	I / O	Description
VDS	1	P	Power Supply for Internal Control Circuits and Gate Drivers
EN	2	I	Enable Control
COMP	3	O	Compensation
FB	4	I	Error Amplifier Inverting Input
RT	5	I	Frequency Programming
CS	6	I	MOSFET Switch Current Sense
HVDD	7	P	IC Power Supply
EXT	8	O	Gate Driver Output
GND	9(EP)	P	IC Ground (Exposed PAD) – Must Connect to Ground

## Marking Information

### SOP-8L(EP)

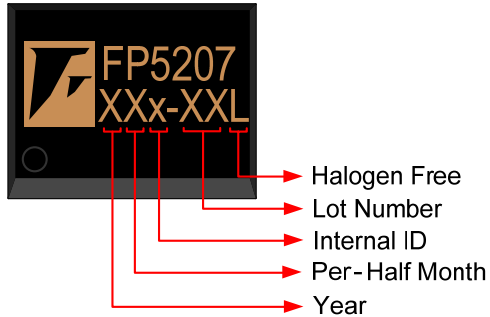

**Halogen Free:** Halogen free product indicator

**Lot Number:** Wafer lot number's last two digits

For Example → Lot : 123456 → XXx-56L

**Internal ID:** Internal Identification Code

**Per-Half Month:** Production period indicator in half month time unit

For Example : A → First Half Month of January

B → Second Half Month of January

C → First Half Month of February

D → Second Half Month of February

**Year:** Production year's last digit

## Ordering Information

Part Number	Operating Temperature	Package	MOQ	Description
FP5207XR-G1	-25°C ~ 85°C	SOP-8L (EP)	2500EA	Tape & Reel

## Absolute Maximum Ratings

Parameter	Symbol	Conditions	Min.	Typ.	Max.	Unit
Supply Voltage	HVDD		-0.3		25	V
VDS,EXT Voltage			-0.3		16	V
Others Pin Voltage			-0.3		6	V
Thermal Resistance (Junction to Ambient)	$\theta_{JA}$	SOP-8L (EP)			+60	°C / W
Thermal Resistance (Junction to Case)	$\theta_{JC}$	SOP-8L (EP)			+10	°C / W
Junction Temperature	$T_J$				+150	°C
Operating Temperature	$T_{OP}$		-25		+85	°C
Storage Temperature	$T_{ST}$		-65		+150	°C
Lead Temperature		(soldering, 10 sec)			+260	°C

## IR Re-flow Soldering Curve

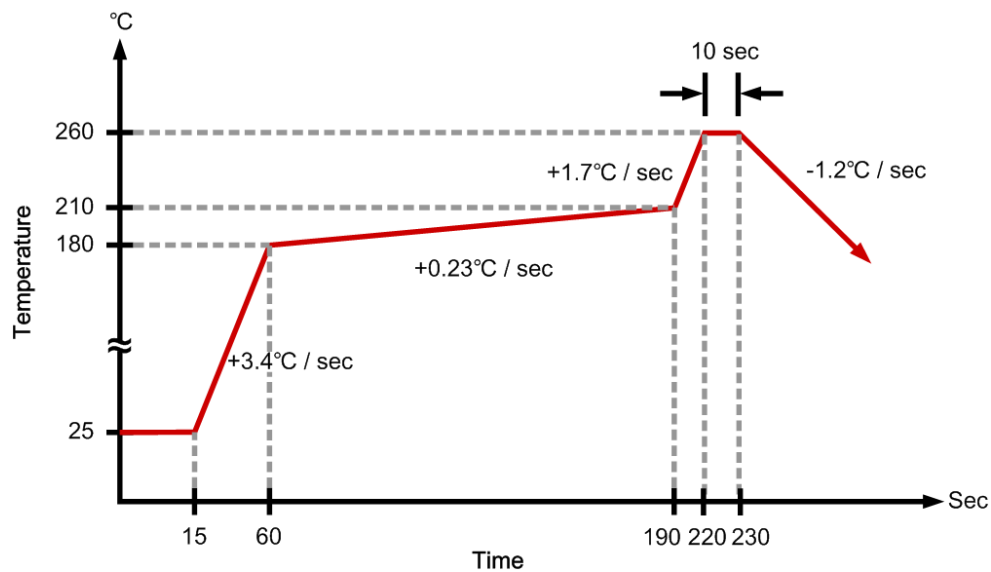

This datasheet contains new product information. Feeling Technology reserves the rights to modify the product specification without notice. No liability is assumed as a result of the use of this product. No rights under any patent accompany the sales of the product.

## Recommended Operating Conditions

Parameter	Symbol	Conditions	Min.	Typ.	Max.	Unit
Supply Voltage	HVDD		5		24	V
Operating Temperature Range	T <sub>A</sub>	Ambient Temperature	-25		+85	°C

## DC Electrical Characteristics (HVDD=12V, T<sub>A</sub>=25°C, unless otherwise specified)

Parameter	Symbol	Conditions	Min.	Typ.	Max.	Unit
<b>System Supply Input</b>						
Start-up Voltage	HVDD				2.8	V
Input Supply Range	HVDD		5		24	V
Under Voltage Lockout	V <sub>UVLO</sub>			2.2		V
UVLO Hysteresis				0.1		V
Average Current	I <sub>CC</sub>	FB=1.0V, Switching		5		mA
Quiescent Current	I <sub>CC</sub>	FB=1.3V, No Switching		700		μA
Shutdown Current	I <sub>CC</sub>	V <sub>EN</sub> =GND			3	μA
Input Supply Voltage	V <sub>DS</sub>	HVDD=12V, I <sub>DS</sub> =0A		8		V
<b>Oscillator</b>						
Operation Frequency	f <sub>OSC</sub>	RT=NC	130	150	170	KHz
		RT=51KΩ		370		KHz
Maximum Duty Ratio	%	FB=1.0V		90		%
<b>Reference Voltage</b>						
Feedback Voltage	V <sub>FB</sub>	HVDD=12V	1.176	1.2	1.224	V
<b>Enable Control</b>						
Enable Voltage	V <sub>EN</sub>			1.5		V
Shutdown Voltage	V <sub>EN</sub>			1.3		V
UVEN Hysteresis				0.2		V
<b>External Transistor Connection current</b>						
EXT Pull-UP Resistance	R <sub>EXTH</sub>	V <sub>DS</sub> =8V		1		Ω
EXT Pull-Down Resistance	R <sub>EXTL</sub>	V <sub>DS</sub> =8V		1		Ω
<b>Current Sense Voltage</b>						
Sense Voltage	V <sub>CS</sub>			100		mV
<b>Thermal Shutdown</b>						
Thermal Shutdown Threshold	T <sub>TS</sub>			+150		°C
Thermal Shutdown Threshold Hysteresis	T <sub>TSH</sub>			30		°C

This datasheet contains new product information. Feeling Technology reserves the rights to modify the product specification without notice. No liability is assumed as a result of the use of this product. No rights under any patent accompany the sales of the product.

## Typical Operating Characteristics

( $T_A=25^{\circ}\text{C}$ , unless otherwise specified)

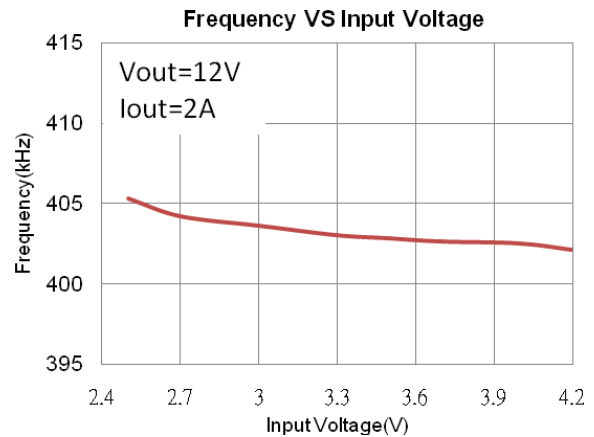
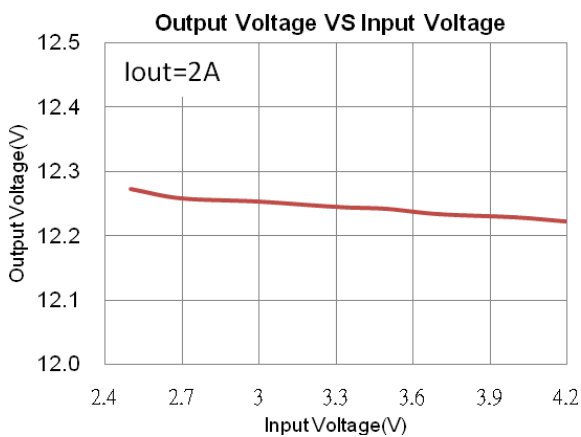
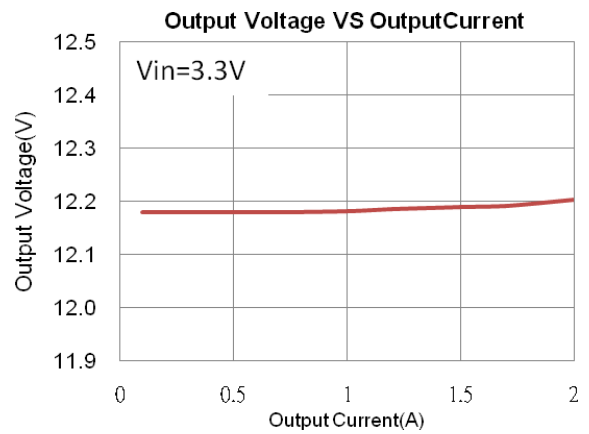
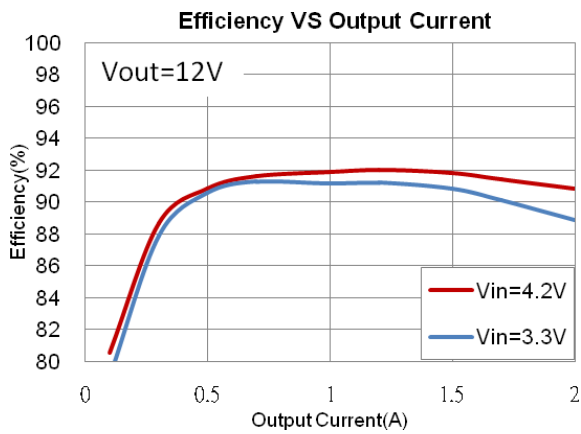
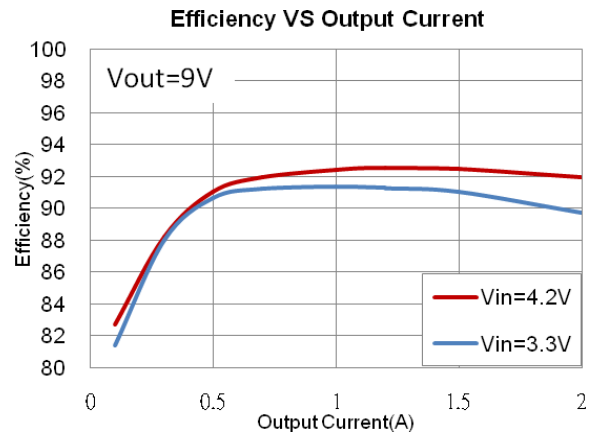
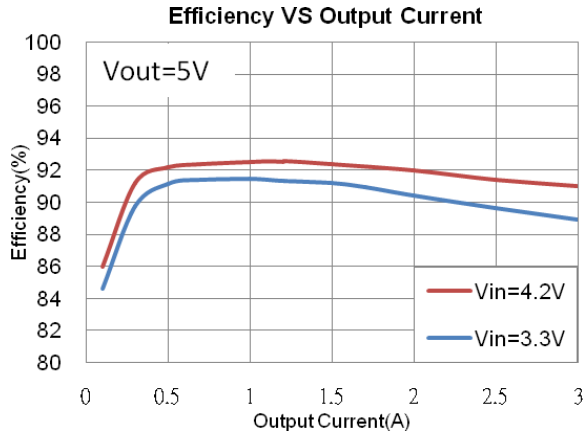

This datasheet contains new product information. Feeling Technology reserves the rights to modify the product specification without notice. No liability is assumed as a result of the use of this product. No rights under any patent accompany the sales of the product.

## Function Description

### Operation

The FP5207 is current mode boost controller. It operates with pulse width modulation (PWM). The internal resistive divider provides 1.2V reference for the error amplifier. It changes to PSM mode when the output is light load. In PSM mode, it can reduce switching lose to raise efficiency, but the output ripple is bigger.

### Soft Start Function

After the IC is enabled, the output of error amplifier is clamped by the internal soft-start function, which causes PWM pulse width increasing slowly and thus reducing input surge current during power on.

### Oscillator

The oscillator frequency can be set from 100KHz to 1000KHz by external resistance. Acceptable resistance values range from 200KΩ to 16KΩ. The frequency is 150KHz when the resistance is unconnected. The relationship between the timing resistance RT and frequency is shown in Figure1. The oscillator frequency can be calculated using formula below.

$$RT(K\Omega) = \frac{17000}{f_{OSC}(KHz) - 25}$$

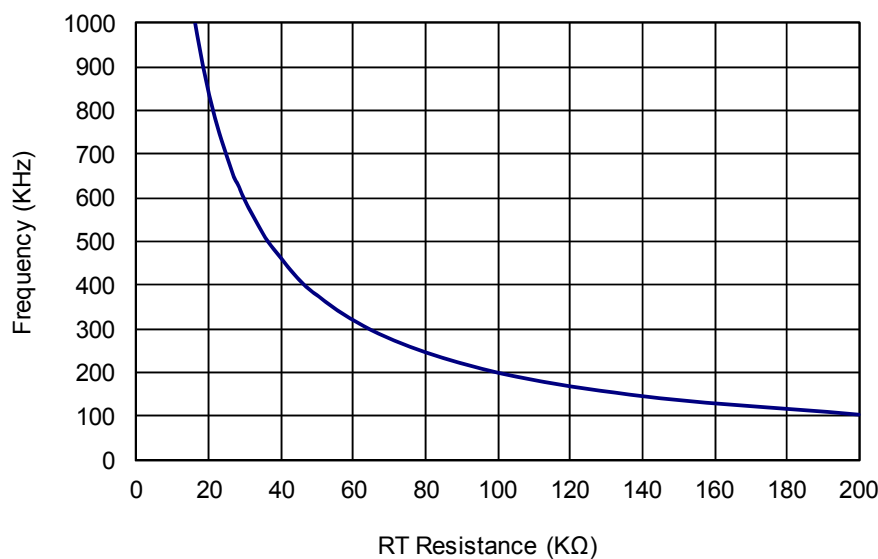

Figure 1. Frequency vs. RT Resistance



### Enable Mode / Shutdown Mode

Input voltage connects to EN pin through a resistive divider to set UVLO threshold. FP7209 is enabled when EN voltage greater than 1.5V. The EN voltage is lower than 1.3V to shutdown it. In shutdown mode, to turn off circuitry includes EXT signal, VDS voltage, and supply current of HVDD reduces less than 3μA. The EN hysteresis voltage is 0.2V. If the applications don't need to set UVLO, the EN connects to input voltage through resistance 200KΩ.

### Current Sense Control

External switching MOSFET is turned on inductor current flows across the current sense resistor to generate  $V_{CS}$ .  $V_{CS}$  provides part of current mode control loop. Internal leading-edge blanking is provided to prevent premature turn off the switching MOSFET in each switching cycle.

### Current Limit Setting Resistor ( $R_{CS}$ )

$R_{CS}$  is connected between CS pin and ground, its calculation formula is as below. Where 0.095V is minimum threshold voltage of current sense,  $I_{Lp}$  is peak inductor current, and the factor 1.3 provides a 30% margin for tolerances.

$$R_{CS} (\Omega) = \frac{0.095V}{I_{Lp}(A) \times 1.3}$$

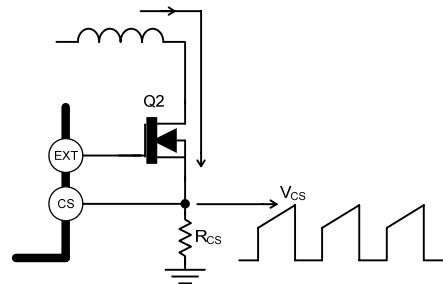

According to following equations calculate the peak inductor current  $I_{Lp}$ . Where  $I_{Lavg}$  is the average inductor current,  $I_{Lpp}$  is the peak-to-peak inductor current,  $V_{out}$  is the LED voltage,  $I_{out(max)}$  is the LED maximum current,  $Eff$  is the efficiency,  $F_s$  is the switching frequency, and the  $L$  is inductance.

$$I_{Lp} = I_{Lavg} + \frac{I_{Lpp}}{2}$$

$$I_{Lavg} = \frac{V_{out} \times I_{out(max)}}{V_{in} \times Eff}$$

$$I_{Lpp} = \left\langle \frac{V_{in}}{V_{out}} \right\rangle^2 \times \left\langle \frac{V_{out} - V_{in}}{F_s \times I_{out(max)}} \right\rangle \times \left\langle \frac{Eff}{L} \right\rangle \times I_{Lavg}$$

## Thermal Shutdown Protection

The IC will shut down automatically when the internal junction temperature exceeds +150°C. The device can restart until the junction temperature drops below +120°C approximately.

## Application Information

### Inductor Selection

The Inductance value is decided based on different condition. 3.3μH to 47uH inductance value is recommended for general application circuit. There are three important inductor specifications, DC resistance, saturation current and core loss. Low DC resistance has better power efficiency. The inductance is calculated using formula. Where  $V_{out}$  is output voltage,  $F_s$  is switching frequency,  $I_{out}$  is output maximum current,  $Eff$  is boost efficiency and  $r$  is the ratio of the inductor peak-to-peak ripple current to the average DC inductor current at full load current.  $r$  is recommended between 0.3 and 0.5.

$$L = \left\langle \frac{V_{in}}{V_{out}} \right\rangle^2 \times \left\langle \frac{V_{out} - V_{in}}{F_s \times I_{out(max)}} \right\rangle \times \left\langle \frac{Eff}{r} \right\rangle$$

### Capacitor Selection

The output capacitor is required to maintain the DC voltage during switching. Low ESR capacitors are preferred to reduce the output voltage ripple. Ceramic capacitor of X5R and X7R are recommended, which have low equivalent series resistance (ESR) and wider operation temperature range.

### Diode Selection

Schottky diodes with fast recovery times and low forward voltages are recommended. Ensure the diode average and peak current rating exceed the average output current and peak inductor current. In addition, the diode's reverse breakdown voltage must exceed the output voltage.

### Output Voltage Programming

The output voltage is set by a resistive voltage divider from the output voltage to FB. The output voltage is:

$$V_{OUT} = 1.2V \times \left\langle 1 + \frac{R11}{R12} \right\rangle$$

### Layout Considerations

1. The power traces, consisting of the GND trace, the MOS drain trace and the  $V_{IN}$  trace should be kept short, direct and wide.
2. Layout switching node MOS drain, inductor and schottky diode connection traces wide and short to reduce EMI.
3. Place C6 nearby HVDD pin as closely as possible to maintain input voltage steady and filter noise.
4. Resistive divider R11 and R12 must be connected to FB and GND pin directly and as closely as possible.
5. FB is a sensitive node. Please keep it away from switching node, MOS drain.
6. The GND of the Q2, C1, C2, C7 and C8 should be connected close and together directly to a ground plane.
7.  $R_{CS}$  must be connected to CS and GND pin directly and as closely as possible.
8. The output capacitor C7 and C8 should be connected close and together directly to the ground of  $R_{CS}$ .

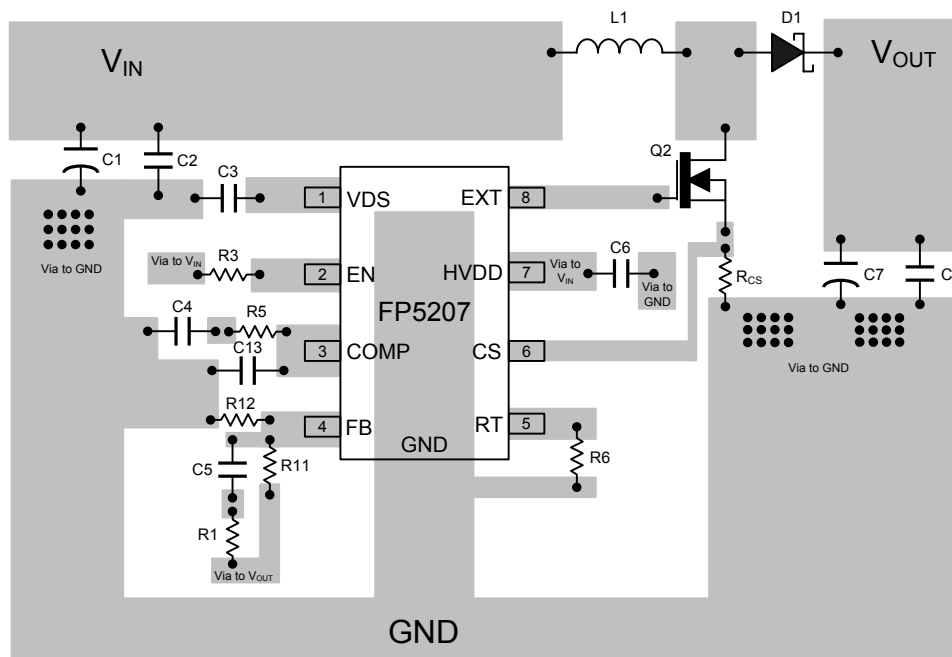

**Suggested Layout**

## Application Information

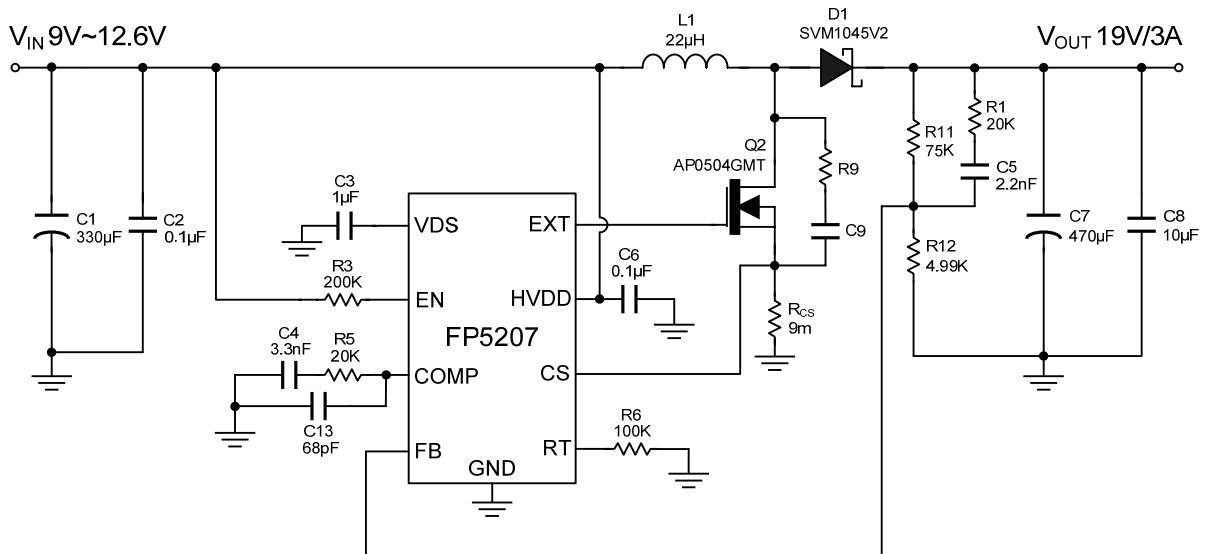
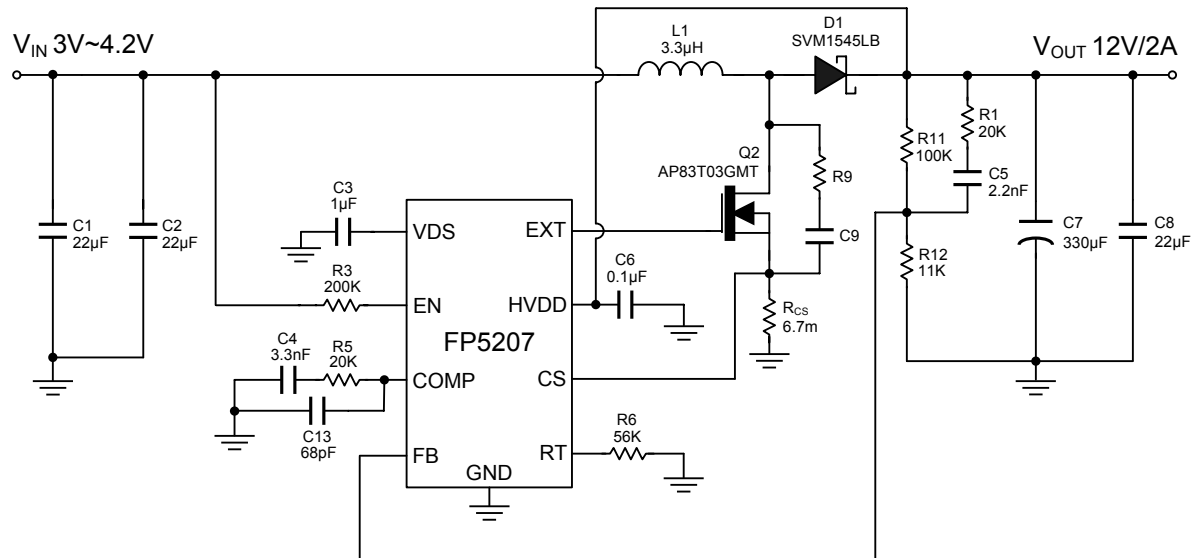

### Note:

1. The X5R and X7R of ceramic capacitors are recommended to choose.
2. R9 and C9 are added for reducing EMI (Electromagnetic Interference).

This datasheet contains new product information. Feeling Technology reserves the rights to modify the product specification without notice. No liability is assumed as a result of the use of this product. No rights under any patent accompany the sales of the product.

## Package Outline

### SOP-8L (EP)

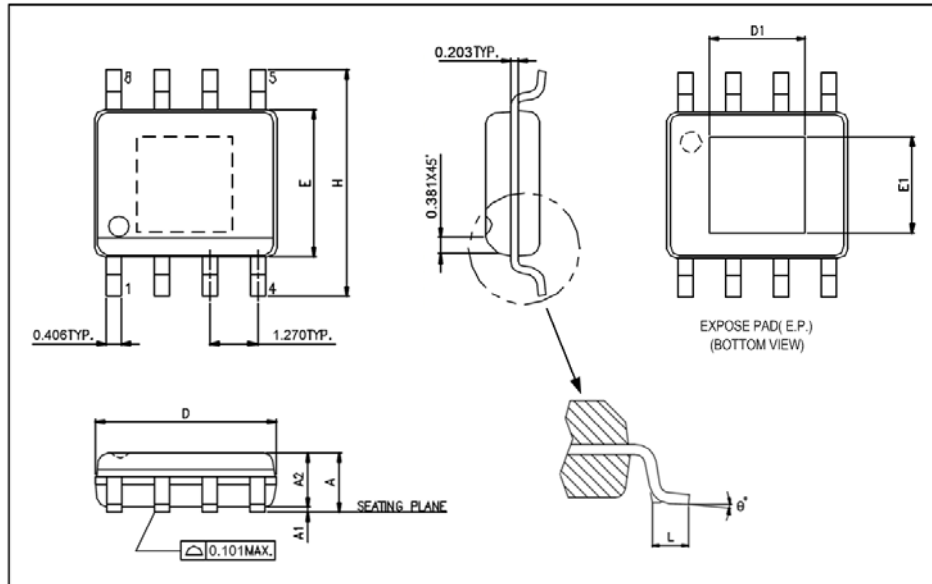

UNIT: mm

Symbols	Min. (mm)	Max. (mm)
A	1.30	1.70
A1	0	0.15
A2	1.25	1.55
D	4.70	5.10
E	3.80	4.00
H	5.80	6.20
L	0.40	1.27

Exposed PAD Dimensions:

Symbols	Min. (mm)	Max. (mm)
D1	2.60	3.45
E1	1.90	2.56

#### Note:

1. Package dimensions are in compliance with JEDEC outline: MS-012 AA.
2. Dimension "D" does not include molding flash, protrusions or gate burrs.
3. Dimension "E" does not include inter-lead flash or protrusions.

This datasheet contains new product information. Feeling Technology reserves the rights to modify the product specification without notice. No liability is assumed as a result of the use of this product. No rights under any patent accompany the sales of the product.