

**DUAL PWM CONTROL IC
WITH SHORT CIRCUIT RESTART FUNCTION****GENERAL DESCRIPTION**

The **FP5453**, a 1-chip composed of totem-pole output stage pulse-width-modulation control circuits with two error amplifiers and dead-time comparators (DTC), the **FP5453** contains a **2.5V** precision voltage reference regulator, under-voltage lockout circuit (UVLO), programmable auto-restart timer for short circuit protection (SCSAR), applied to offer space and low cost in many applications such as the DC/DC converter.

Using few external components, **FP5453**, a high performance integrated IC, is designed for a control circuit. The circuit diagram of the typical application example is as below.

FEATURES

- Fixed Reference Voltage: 2.5V
- Reference Voltage Precision: 2%
- Totem-pole output stage
- Low quiescent supply current under 4mA
- Wide operating voltage range: 3.6~25V
- Variable dead-time control (DTC)
- UVLO protection function
- Short circuit shutdown/auto re-start function (SCSAR)
- Oscillator Frequency: Max. 1.2MHz
- Package: SOP16/PDIP16/SSOP16/SOP16(EP)

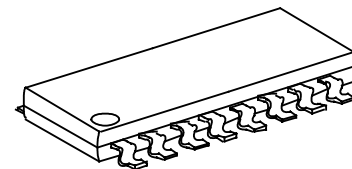
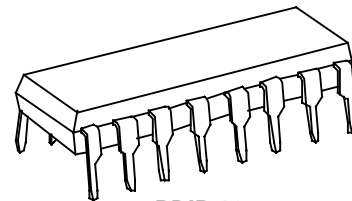
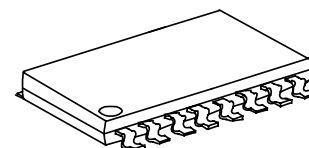
**SOP16****PDIP 16****SSOP 16****TYPICAL APPLICATION**

- HUB/Router
- Set Top Box
- HDD Server
- CATV
-

FUNCTIONAL BLOCK DIAGRAM

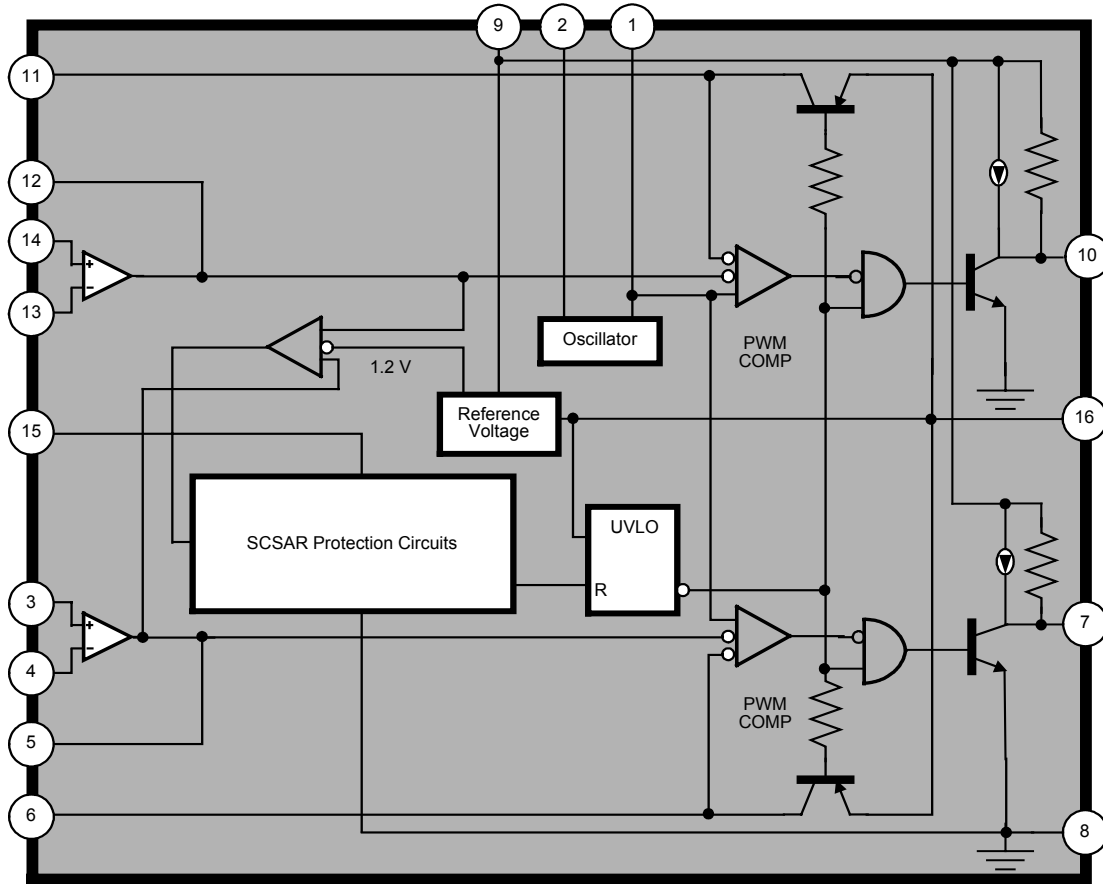

MARK VIEW

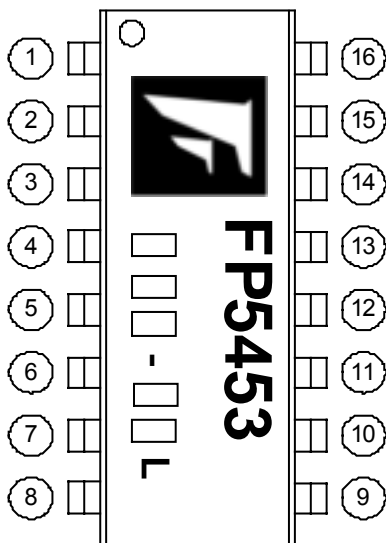

PIN DESCRIPTION

| NAME | NO. | STATUS | DESCRIPTION |
|-------|-----|--------|---------------------------------------|
| CT | 1 | I | Connect a Capacitor for Oscillator |
| RT | 2 | I | Connect a Resistor for Oscillator |
| EA1+ | 3 | I | Error Amplifier 1 Non-inverting Input |
| EA1- | 4 | I | Error Amplifier 1 Inverting Input |
| FB1 | 5 | O | Error Amplifier 1 Feedback Output |
| DTC1 | 6 | I | Output 1 Dead-Time Comparator |
| OUT1 | 7 | O | Totem-pole Output 1 |
| GND | 8 | P | IC Ground |
| VCC | 9 | P | IC Power Supply |
| OUT2 | 10 | O | Totem-pole Output 2 |
| DTC2 | 11 | I | Output 2 Dead-Time Comparator |
| FB2 | 12 | O | Error Amplifier 2 Feedback Output |
| EA2- | 13 | I | Error Amplifier 2 Inverting Input |
| EA2+ | 14 | I | Error Amplifier 2 Non-inverting Input |
| SCSAR | 15 | I | Short Circuit Protection Input |
| VREF | 16 | O | 2.5V Reference Voltage Output |

ORDER INFORMATION

| Part Number | Operating Temperature | Package | Description |
|-------------|-----------------------|-----------|-------------|
| FP5453P-LF | -20°C ~ +85°C | PDIP16 | Tube |
| FP5453D-LF | -20°C ~ +85°C | SOP16 | Tube |
| FP5453DR-LF | -20°C ~ +85°C | SOP16 | Tape & Reel |
| FP5453R-LF | -20°C ~ +85°C | SSOP16 | Tube |
| FP5453RR-LF | -20°C ~ +85°C | SSOP16 | Tape & Reel |
| FP5453X-LF | -20°C ~ +85°C | SOP16(EP) | Tube |
| FP5453XR-LF | -20°C ~ +85°C | SOP16(EP) | Tape & Reel |

IC DATE CODE DISTINGUISH

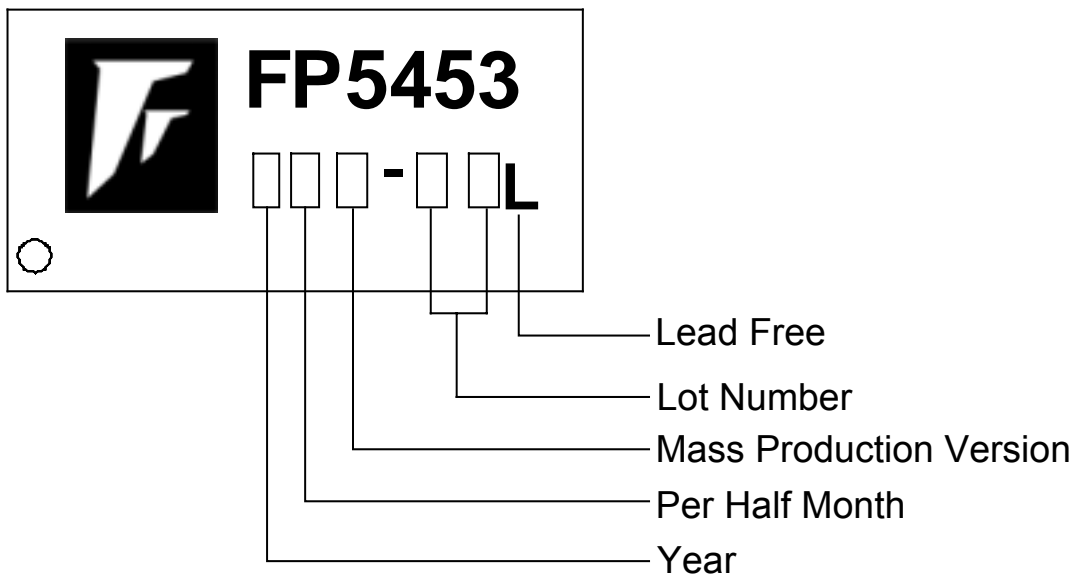

FOR EXAMPLE:

January A (Front Half Month), B (Last Half Month)
 February C, D
 March E, F -----And so on

Lot Number is the last two numbers

For Example:

A3311C**62**
 └───▶ Lot Number

ABSOLUTE MAXIMUM RATINGS

| | | |
|--|-------|-------------|
| Supply Voltage (V _{cc}) | ----- | +25V |
| Differential Input Voltage (V _{id}) | ----- | +3V |
| Output Current (I _o) | ----- | +150mA |
| Maximum Junction Temperature (T _j) | ----- | +150°C |
| Thermal Resistance Junction to Ambient | | |
| PDIP16 package | ----- | 125°C /W |
| SOP16 package | ----- | 150°C /W |
| SSOP16 package | ----- | 220°C /W |
| Power Dissipation | | |
| DIP16 package | | |
| Ta=25 | ----- | 1000mW |
| Ta=70 | ----- | 640mW |
| SOP16 package | | |
| Ta=25 | ----- | 830mW |
| Ta=70 | ----- | 530mW |
| SSOP16 package | | |
| Ta=25 | ----- | 570mW |
| Ta=70 | ----- | 360mW |
| Operating Temperature Range | ----- | -20°C 85°C |
| Storage Temperature Range | ----- | -65°C 150°C |
| Lead Temperature (soldering, 10 sec) | ----- | +260°C |

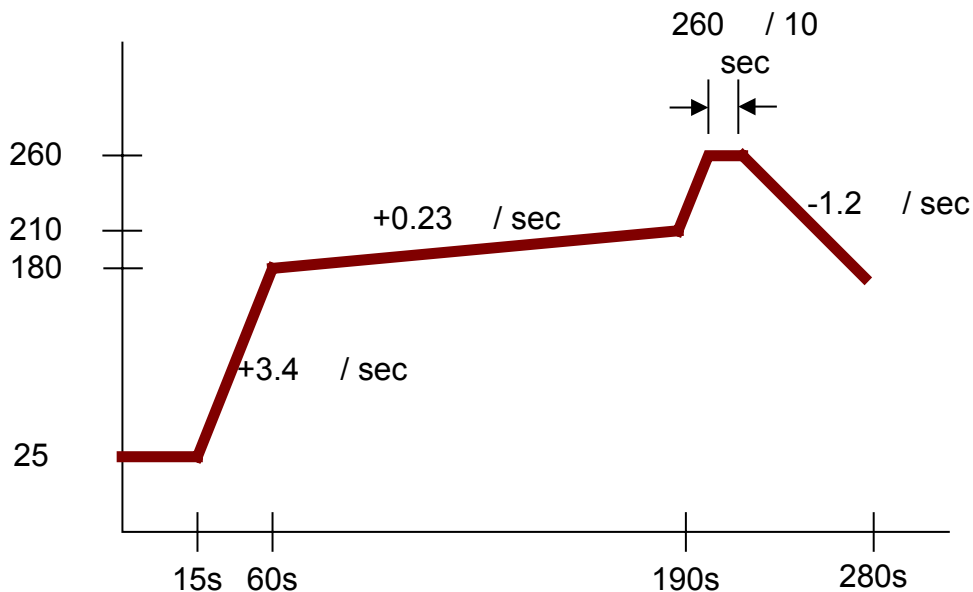

IR Re-flow Soldering Curve

DC ELECTRICAL CHARACTERISTICS

Electrical characteristics over recommended operating free-air temperature range, $V_{CC}=6V$, $f=200kHz$ (unless otherwise noted)

Reference section

| PARAMETER | SYMBOL | TEST CONDITIONS | MIN | TYP | MAX | UNIT |
|--|-------------------|---------------------|------|------|---------|------|
| Output voltage (pin 16) | V_{REF} | $I_O=1mA$ | 2.45 | 2.5 | 2.55 | V |
| Output voltage change with Temperature | | $T_A=-20$ to 25 | | -0.1 | ± 1 | % |
| | | $T_A=25$ to 85 | | -0.2 | ± 1 | |
| Input voltage regulation | V_{REF}/V_{REF} | $V_{CC}=3.6V$ 25V | | 2 | 12.5 | mV |
| Output voltage regulation | V_{REF}/V_{REF} | $I_O=0.1mA$ to 1 mA | | 3 | 8 | mV |
| Short-circuit output current | I_{SHORT} | $V_O=0$ | 3 | 10 | 30 | mA |

Under voltage lockout section

| PARAMETER | SYMBOL | TEST CONDITIONS | MIN | TYP | MAX | UNIT |
|-------------------------------------|-------------|----------------------------------|-----|-----|-----|------|
| Upper threshold voltage(V_{CC}) | V_{UPPER} | $I_{O(REF)}=0.1mA$, $T_A=25$ | | 3.2 | | V |
| Lower threshold voltage(V_{CC}) | V_{LOW} | | | 3.0 | | V |
| Hysteresis (V_{CC}) | V_{HYS} | | 100 | 200 | | mV |

Short-circuit protection control section

| PARAMETER | SYMBOL | TEST CONDITIONS | MIN | TYP | MAX | UNIT |
|------------------------------------|-------------------|-------------------------------|-----|------|-----|---------|
| SCP re-start voltage | V_{RS} | V_{FB1} or $V_{FB2} < 1.5V$ | | 0.5 | | V |
| SCP threshold voltage | V_{TH} | V_{FB1} or $V_{FB2} < 1.5V$ | | 1.0 | | V |
| SCP re-start charge current | I_{RSC} | V_{FB1} or $V_{FB2} < 1.5V$ | | 20 | | μA |
| SCP re-start / hold time | T_{RS}/T_{HOLD} | V_{FB1} or $V_{FB2} < 1.5V$ | | 1/50 | | - |
| SCP comparator 1 threshold voltage | $V_{COMP(TH)}$ | | | 1.2 | | V |

Oscillator section

| PARAMETER | SYMBOL | TEST CONDITIONS | MIN | TYP | MAX | UNIT |
|-----------------------------------|--------|----------------------|-----|------|---------|------|
| Frequency | f | $C_T=330pF, R_T=10K$ | | 200 | | KHz |
| Frequency change with voltage | f/ V | $V_{CC}=3.6V$ to 25V | | 0.2 | | % |
| Frequency change with Temperature | f/ T | $T_A=-20$ to 25 | | -0.4 | ± 2 | % |
| | | $T_A=25$ to 85 | | -0.2 | ± 2 | |

DC ELECTRICAL CHARACTERISTICS (Cont.)

Dead-time control section

| PARAMETER | SYMBOL | TEST CONDITIONS | MIN | TYP | MAX | UNIT |
|--------------------------|------------|--------------------|-----|-----|------|---------|
| Input bias current (DTC) | I_{BIAS} | | | | 1 | μA |
| Input threshold voltage | V_{TH} | Zero duty cycle | | 2.0 | 2.20 | V |
| | | Maximum duty cycle | 1.2 | 1.4 | | |

Error –amplifier section

| PARAMETER | SYMBOL | TEST CONDITIONS | MIN | TYP | MAX | UNIT |
|------------------------------------|--------------|---------------------------|---------------|------|-----------|---------|
| Input offset voltage | V_{IO} | $V_{FB}=1.25V$ | | | ± 6 | mV |
| Input offset current | I_{IO} | $V_{FB}=1.25V$ | | | ± 100 | nA |
| Input bias current | I_{BIAS} | $V_{FB}=1.25V$ | | 160 | 500 | nA |
| Open-loop voltage amplification | A_{VO} | | 70 | 80 | | dB |
| Unity-gain bandwidth | BW | | | 1.5 | | MHz |
| Positive output voltage swing | V_{POS} | | $V_{ref}-0.3$ | | | V |
| Negative output voltage swing | V_{NEG} | | | | 1 | V |
| Output (sink) current (FEEDBACK) | I_{SINK} | $V_{ID}=-0.1V, V_O=1.25V$ | 2 | 3 | | mA |
| Output (source) current (FEEDBACK) | I_{SOURCE} | $V_{ID}=0.1V, V_O=1.25V$ | -100 | -140 | | μA |

Output section

| PARAMETER | SYMBOL | TEST CONDITIONS | MIN | TYP | MAX | UNIT |
|-------------------|----------|------------------------------------|------|------|-----|------|
| Vout Low Voltage | V_{OL} | $I_{SINK}=20mA$ | | 0.18 | 0.2 | V |
| | | $I_{SINK}=130mA$ $V_{CC}=15V$ | | 1.7 | 2.0 | |
| Vout High Voltage | V_{OH} | $I_{SOURCE}=20mA$ | 4.0 | 4.5 | | V |
| | | $I_{SOURCE}=130mA$ $V_{CC}=15V$ | 12.8 | 13.4 | | |
| Rise Time | t_R | $T_J=25, C_L=1nF$ | | 50 | 100 | nS |
| Fall Time | t_F | $T_J=25, C_L=1nF$ | | 50 | 100 | nS |

PWM comparator section

| PARAMETER | SYMBOL | TEST CONDITIONS | MIN | TYP | MAX | UNIT |
|---|----------|--------------------|-----|-----|------|------|
| Input threshold voltage at $f=10kHz$ (FEEDBACK) | V_{TH} | Zero duty cycle | | 2.0 | 2.20 | V |
| | | Maximum duty cycle | 1.2 | 1.4 | | |

Total device

| PARAMETER | SYMBOL | TEST CONDITIONS | MIN | TYP | MAX | UNIT |
|------------------------|---------------|-----------------|-----|-----|-----|------|
| Standby supply current | $I_{STANDBY}$ | Off-state | | 4.0 | 5.5 | mA |
| Average supply current | I_{AVE} | $R_T=10K$ | | 4.5 | 6.0 | mA |

TYPICAL CHATAACTERISTICS

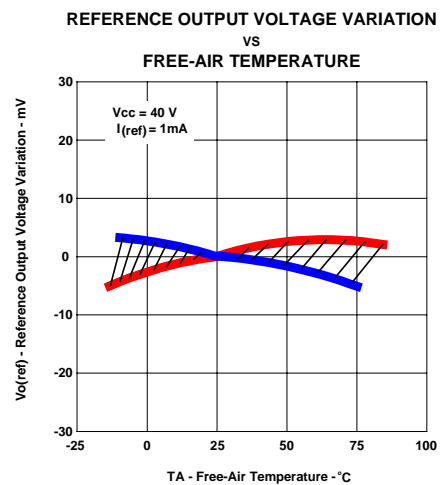
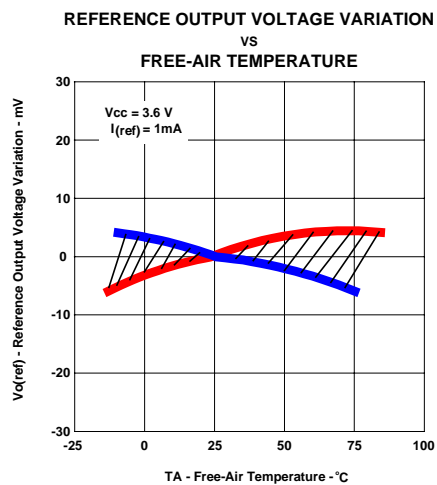
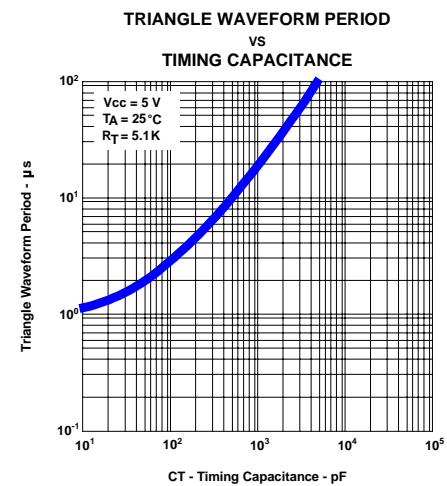
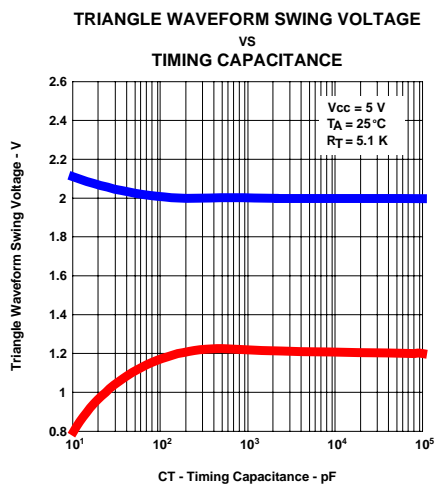
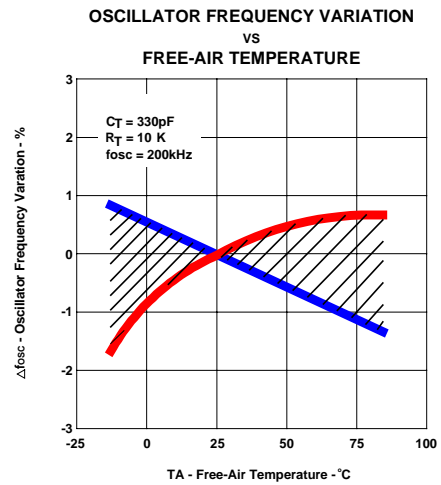
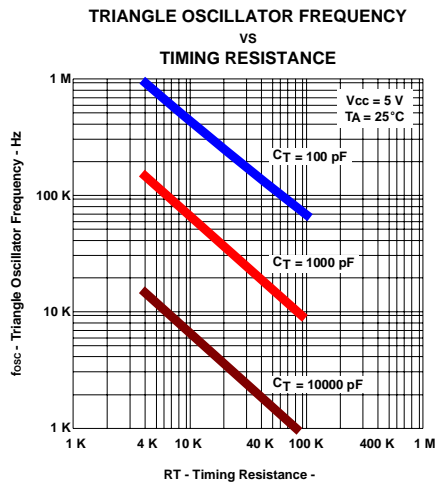

TYPICAL CHATACTERISTICS (Cont.)

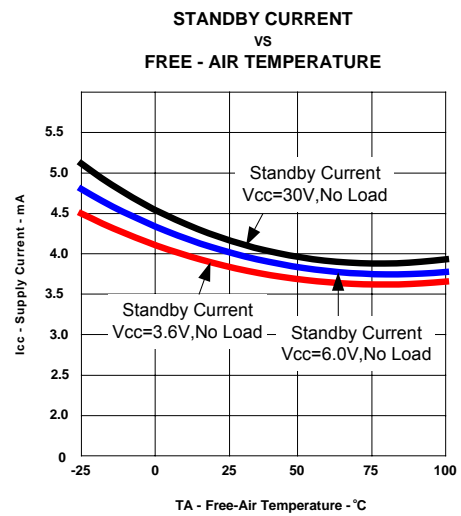
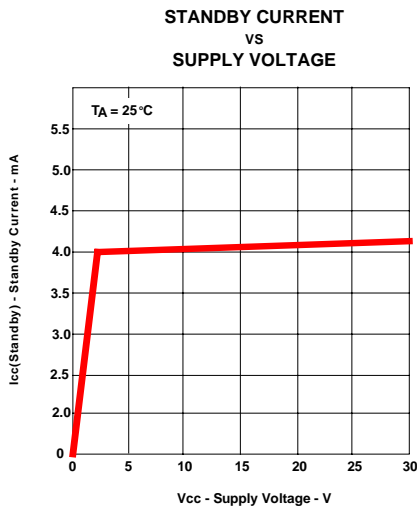
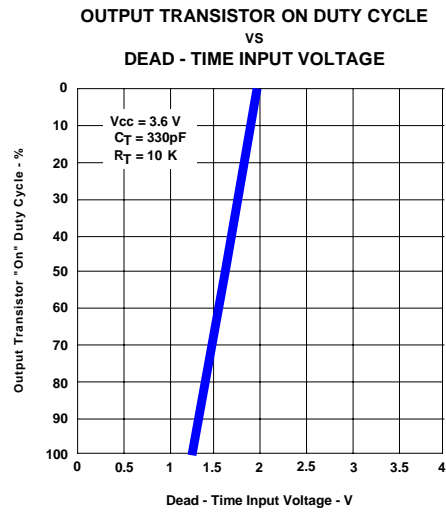
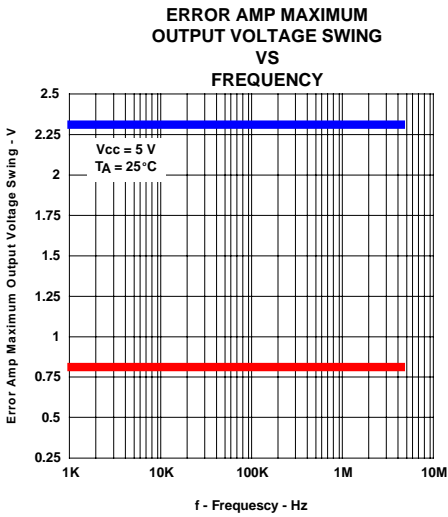
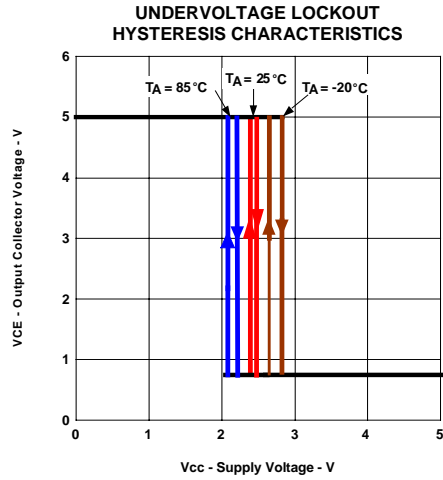
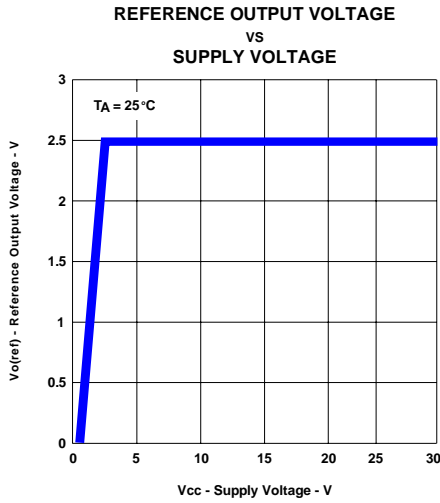

TIMING WAVEFORM

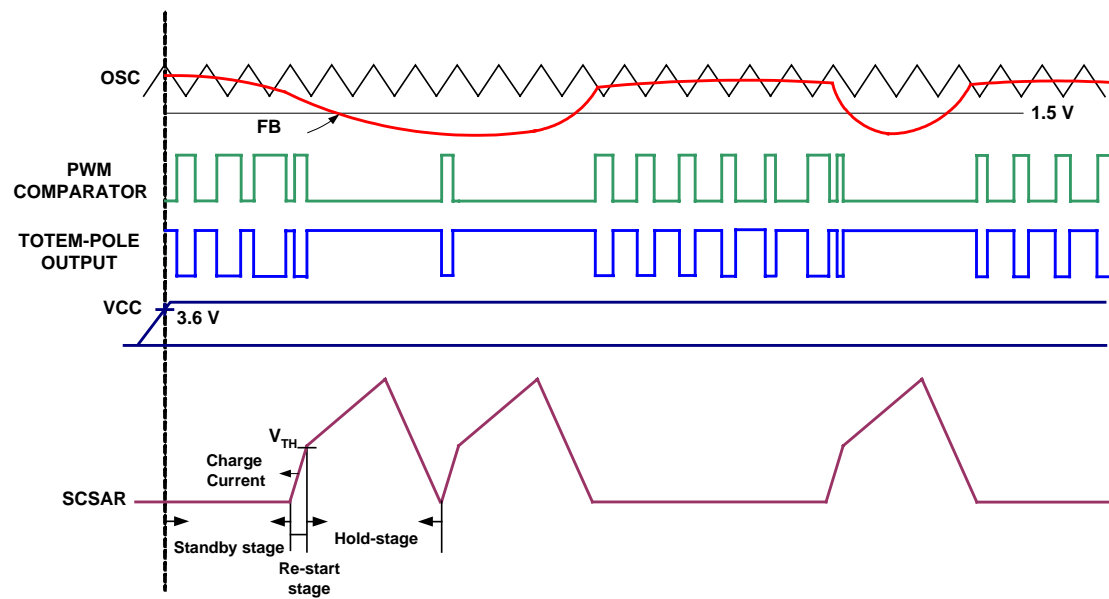

Figure 13. FP5453 Timing Diagram

DETAILED DESCRIPTION

Voltage Reference

FP5453 has an internal 2.5V reference regulator using for the internal circuits' voltage bias, and another function is using with the resistive divider connecting to the IC error amplifier inverting input for output feedback reference(see Fig 14).

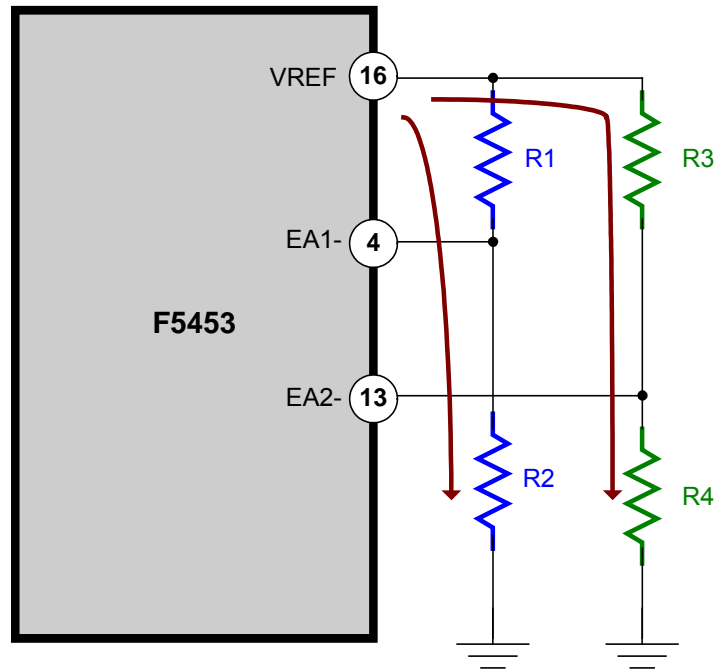

Figure 14. Reference and error amplifiers with resistive dividers

The error amplifier inverting input (EA1- or EA2-) reference voltage formulas are shown as below:

$$V_{EA1-} = VREF(2.5V) \times \frac{R2}{R1 + R2}$$

$$V_{EA2-} = VREF(2.5V) \times \frac{R4}{R3 + R4}$$

And we will discuss both relationship of the output voltage and error amplifier reference voltage next page.

Error Amplifier

The error amplifiers of **FP5453** compare the feedback voltage from the resistive dividers of dc-dc converter output to the reference bias(see Fig 15), and generate the error signal for the PWM comparator, the relation formulas are shown as below:

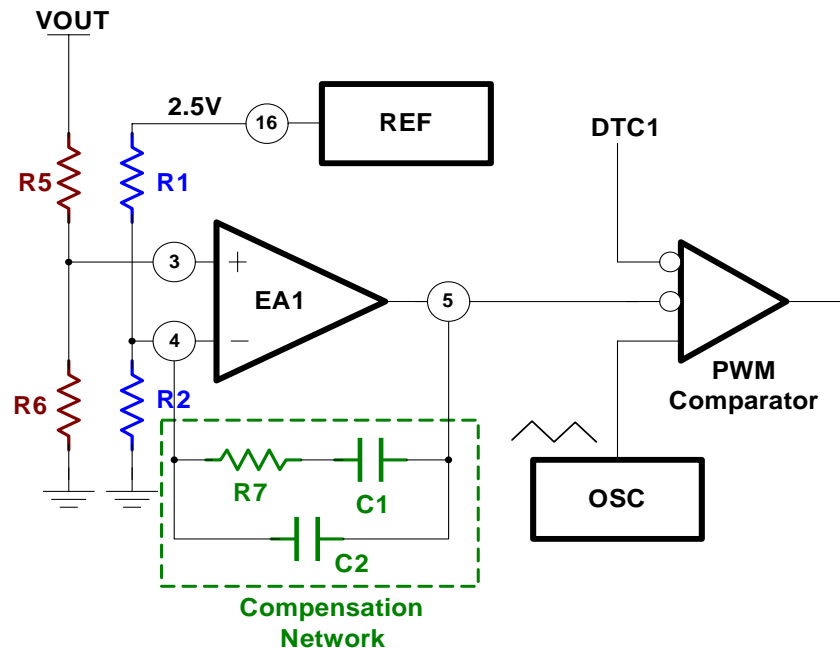

Figure 15. Error amplifier with Feedback/Compensation Circuits

The Buck converter output voltage:

$$V_{OUT} = \left(1 + \frac{R5}{R6}\right) \times \left(\frac{R2}{R1 + R2}\right) \times 2.5V$$

Error Amplifier Gain:

$$A_v = 1 + \frac{1 + sR7C1}{sR_i(C1 + C2)(1 + sR7C2)} \quad , R_i = R1 // R2$$

Error Amplifier Zero and Pole Frequency:

$$F_z = \frac{1}{2\pi R7C1} \quad , \quad F_p = \frac{1}{2\pi R7C2}$$

Oscillator/PWM Comparator

The oscillator frequency can be decided from 20KHz to 1.2MHz by the resistor (RT) and capacitor (CT) which are connected with pin1 and pin2 of **FP5453**, a sawtooth waveform would compare with feedback signal of the error amplifier and dead-time control voltage, the figure 16 is the relationship of oscillator, error amplifier and PWM comparator, and figure 17 is the waveforms of **FP5453**.

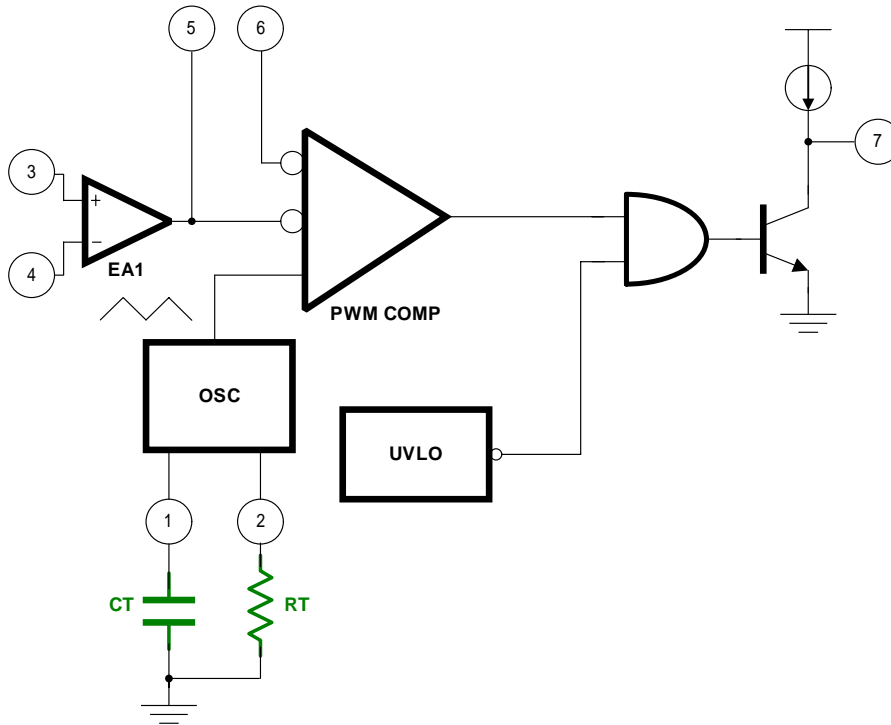

Figure 16. Oscillator/PWM Comparator with Frequency RC circuits

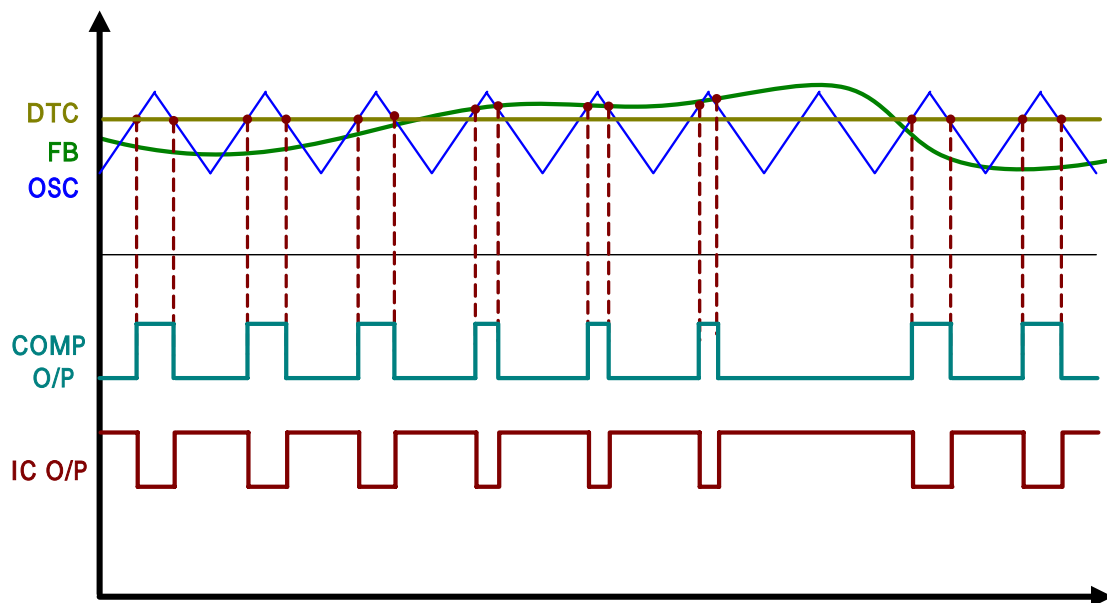

Figure 17. FP5453 Timing Waveforms

The relationship of oscillator waveform and dead-time voltage is shown below (see Fig 18):

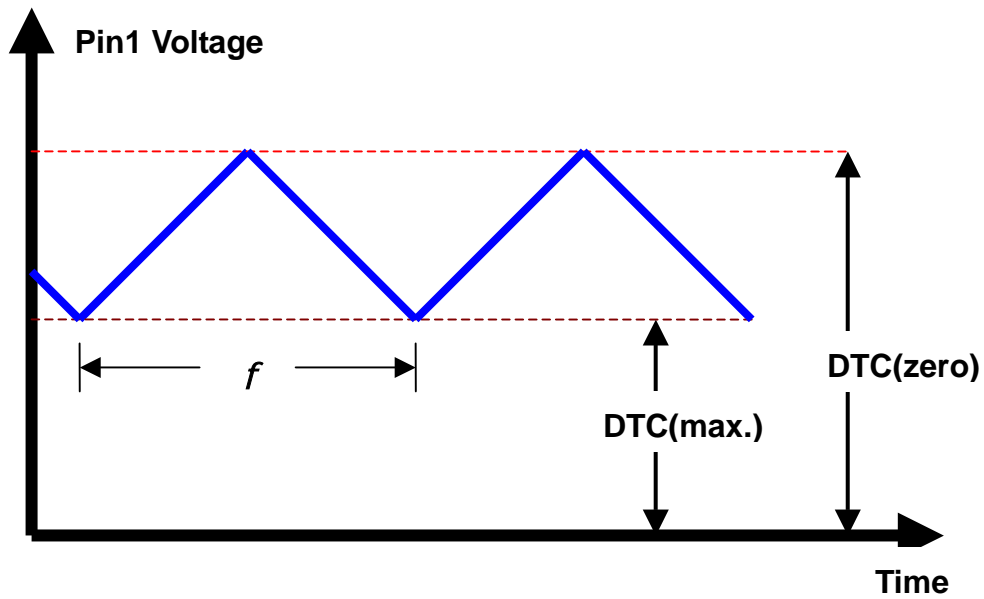

Figure 18. Oscillator Frequency with DTC voltage

The oscillator frequency calculation formula is shown as below:

$$f = \frac{VT}{2 * CT * RT * (V_{zero} - V_{max.})}$$

Dead-Time Control/Soft-Start

The dead-time control (DTC) is a function for the PWM duty cycle limitation, if the DTC voltage is lower than DTC maximum voltage (typ. 1.35V), the PWM duty cycle can change to 100% cycle; and if the DTC voltage is higher than DTC zero voltage (typ. 2.0V), the PWM duty cycle should always turn-off (zero duty).

The system of DC-DC converter can use DTC function with an external RC for Power-On soft-start (see Fig 19) and a simple formula to calculate the soft-start time.

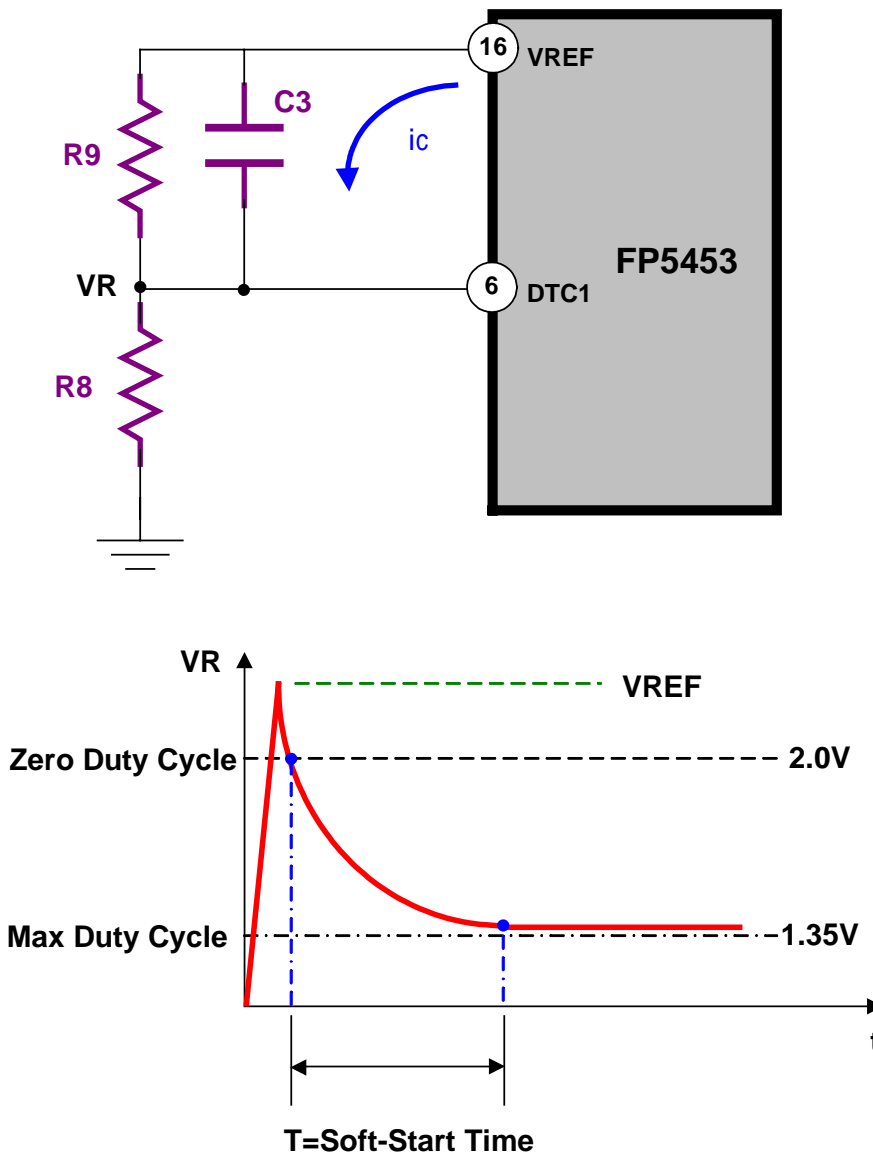

Figure 19. DTC Soft-start RC circuit and waveform

The soft-start time formula:

$$t = 5 * \left(\frac{R9 * R8}{R9 + R8} \right) * C3$$

Short-circuit shutdown and auto re-start protection (SCSAR)

FP5453 includes short-circuit shutdown and auto re-start protection function (see Figure 20), which turns the Power MOS off to prevent damage when the converter output is over loading or short circuit.

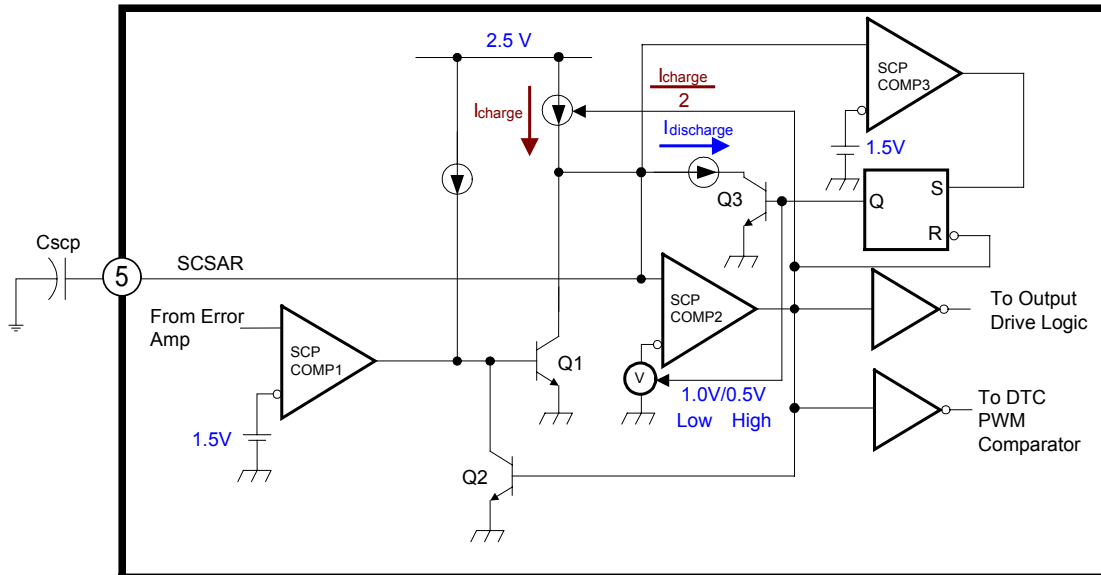

Figure 20. SCSAR Protection Circuit

Generally, error amplifier output voltage is higher than 1.5V, and SCP comparator 1 output keeps a high state and Q1 is turn-on, C_{SCP} cannot be charged. When short circuit occurs, the COMP pin of error-amplifier would under more than 1.50V, SCP comparator 1 output changes to low state and C_{SCP} is charged by I_{CHARGE} current. The SC function of **FP5453** is release because short circuit is removed before Q2 active and SCP comparator 2 is latch. When C_{SCP} is charged until a 1.0V threshold voltage and SCP comparator 2 output changes to high state and Q2 is turn-on to keep Q1 off in latch mode. Meanwhile, the source current of C_{SCP} would change half of original current for the first shutdown phase, **FP5453** output is turn-off and DTC pin is pull-low. When C_{SCP} voltage is greater than 1.5V of SCP comparator 3, the output of S-R Latch would turn on Q3 and change SCP comparator 2 from 1.0V to 0.5V, when SCP comparator 3 is active, C_{SCP} is discharged until SCP comparator 2 is release the latch state, output of **FP5453** is active and DTC pin is working in soft-start state or limitation of duty cycle.

C_{SCP} discharging time from 1.5V to 0.5V is the second shutdown phase which finishes and **FP5453** would be release shutdown state and re-start the normal operation. Figure 21 is a relation description about SCSAR pin and the other pins of **FP5453**.

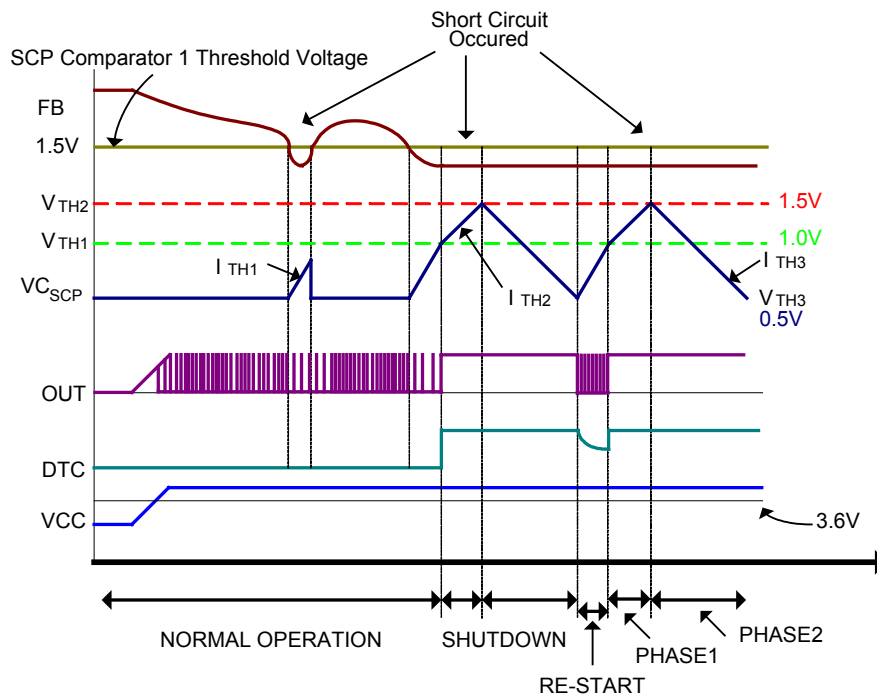

Figure 21. Shutdown and Re-start waveform

The formulas are shown below for shutdown and re-start time calculation:

AUTO RE-START time equation:

$$t_{RE-START} = \frac{V_{TH1} * C_{SCP}}{I_{TH1}}$$

SHUTDOWN time equation:

$$t_{SHUTDOWN} = t_{PHASE1} + t_{PHASE2} = \frac{(V_{TH2} - V_{TH1}) * C_{SCP}}{I_{TH2}} + \frac{(V_{TH2} - V_{TH3}) * C_{SCP}}{I_{TH3}}$$

Output transistors

The output of the **FP5453** is a totem-pole transistor pair, which supplies source and sink current capacity for driving the external MOSFET directly, a basic drive method is shown as figure 22.

When PWM operation frequency is different, the both of on and off time of MOSFET also are different.

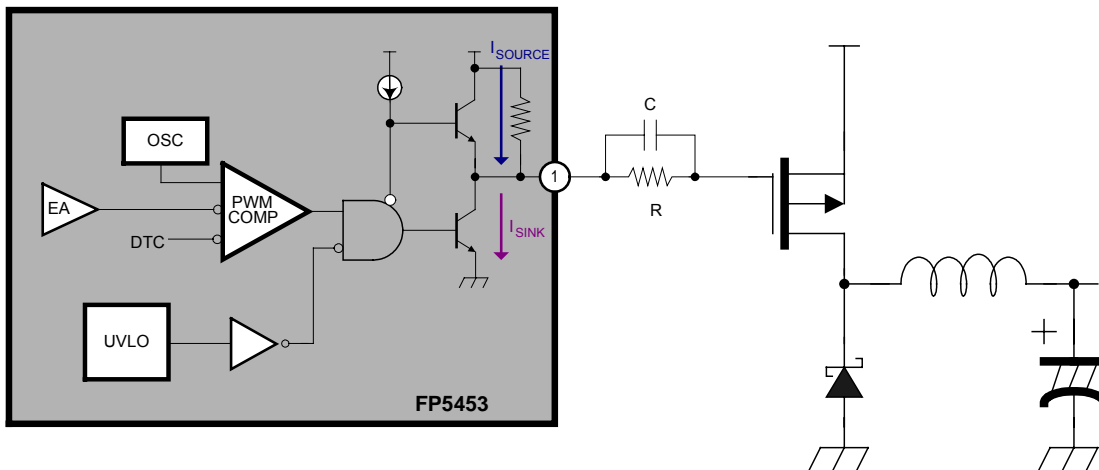

Figure 22. FP5453 MOSFET Output Driving Circuit

Note:

It is very important to choose a suitable MOSFET for high frequency operation. The larger capacitor between gate and source of MOSFET has more switching loss under the same condition as high frequency operation, supply voltage and driving current.

APPLICATION NOTE

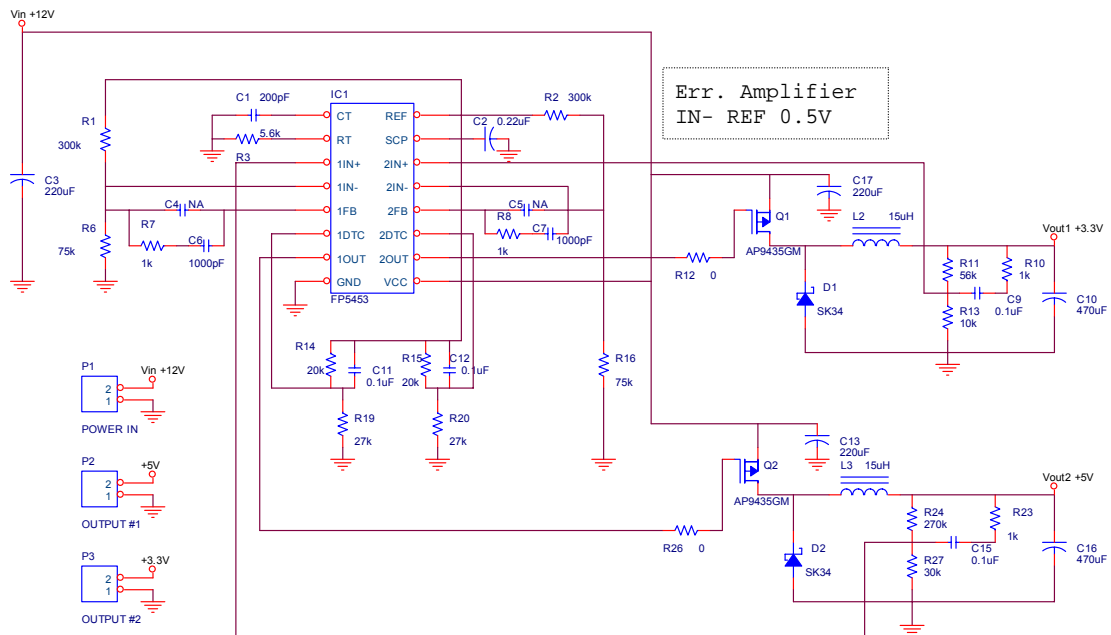

Figure 23. 2-channel dc-dc converter circuit

Note

1. The IN1- and IN2- is 1.25V a half of VREF voltage because $R1=R6$ and $R2=R16$.
2. The R14-R19-C11 and R15-R20-C12 are a DTC circuits for Buck Regulators power-on.
3. The R11-R13 and R24-R27 are the buck regulator output voltage feedback resistances.
4. The R7-C4-C6 is the compensation circuit for error amplifier 1 of FP5453.
5. The R8-C5-C7 is the compensation circuit for error amplifier 2 of FP5453.
6. The R3-C1 is an external RC circuit for FP5453 internal oscillator.
7. The C2 is FP5453 short circuit protection delay time capacitor.

PACKAGE OUTLINE

SOP-16L

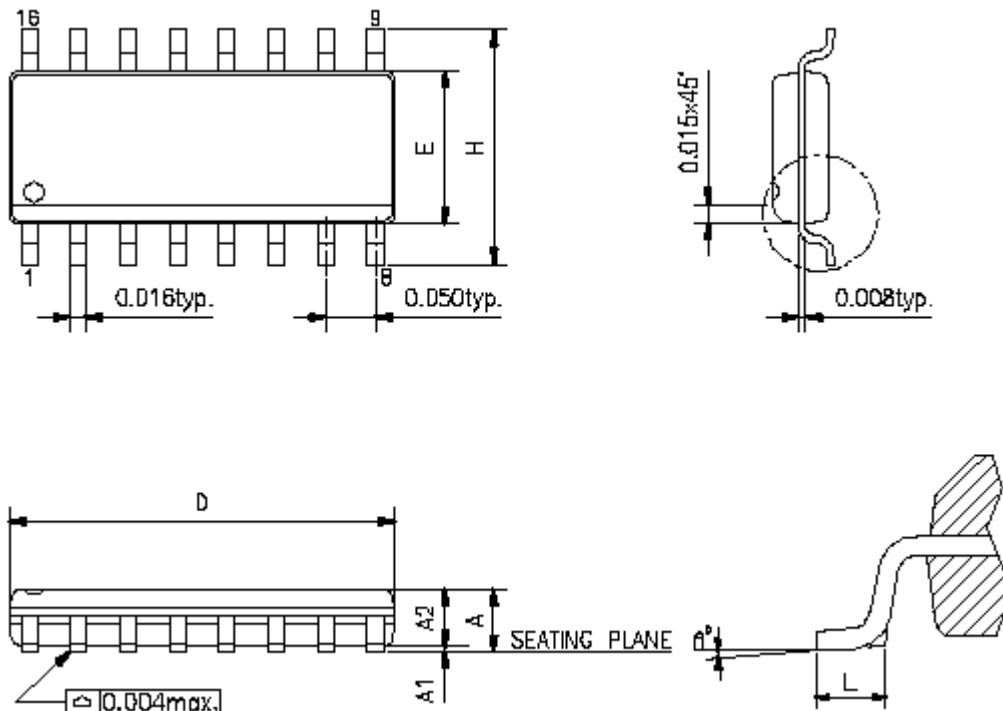

| SYMBOLS | MIN | MAX |
|---------|-------|-------|
| A | 0.053 | 0.069 |
| A1 | 0.004 | 0.010 |
| D | 0.386 | 0.394 |
| E | 0.150 | 0.157 |
| H | 0.228 | 0.244 |
| L | 0.016 | 0.050 |
| ° | 0 | 8 |

UNIT:INCH

NOTE:

- 1.JEDEC OUTLINE:MS-012 AC
- 2.DIMENSIONS "D" DOES NOT INCLUDE MOLD FLASH,PROTRUSIONS OR GATE BURRS.MOLD FLASH,PROTRUSIONS AND GATE BURRS SHALL NOT EXCEED .15mm (.006in) PER SIDE
- 3.DIMENSIONS "E" DOES NOT INCLUDE INTER-LEAD FLASH,OR PROTRUSIONS.
- 4.INTER-LEAD FLASH AND PROTRUSIONS SHALL NOT EXCEED .25mm (.010in) PER SIDE.

PDIP-16L

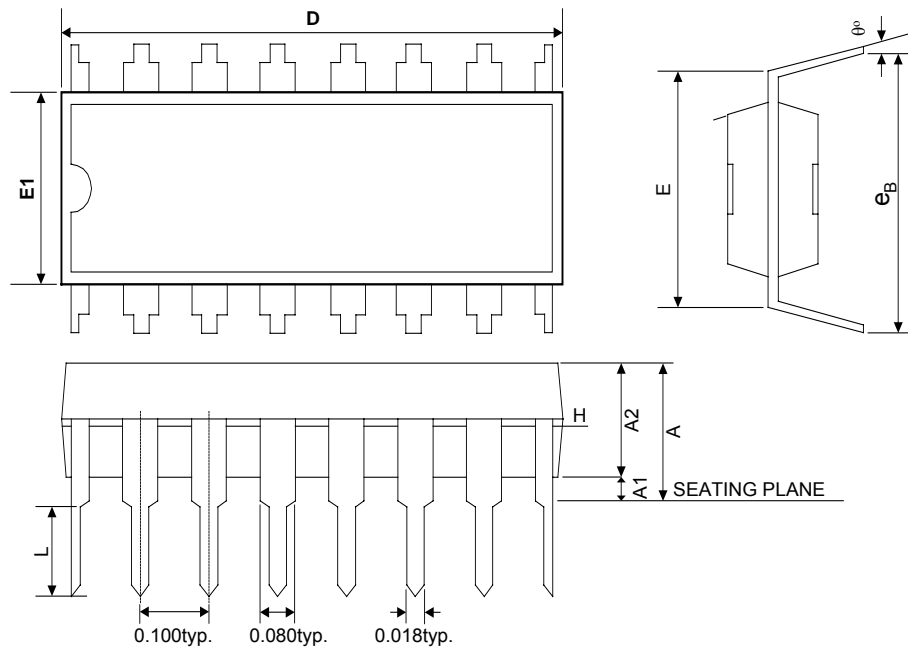

| SYMBOLS | MIN. | NOR. | MAX. |
|----------|------------|-------|-------|
| A | — | — | 0.210 |
| A1 | 0.015 | — | — |
| A2 | 0.125 | 0.130 | 0.135 |
| D | 0.735 | 0.755 | 0.775 |
| E | 0.300 BSC. | | |
| E1 | 0.245 | 0.250 | 0.255 |
| L | 0.115 | 0.130 | 0.150 |
| e_B | 0.335 | 0.355 | 0.375 |
| $^\circ$ | 0 | 7 | 15 |

UNIT:INCH

NOTES:

1. JEDEC OUTLINE: MS-001 BB
2. "D", "E1" DIMENSIONS DO NOT INCLUDE MOLD FLASH OR PROTRUSIONS. MOLD FLASH OR PROTRUSIONS SHALL NOT EXCEED .010 INCH.
 e_B IS MEASURED AT THE LEAD TIPS WITH THE LEADS UNCONSTRAINED.
POINTED OR ROUNDED LEAD TIPS ARE PREFERRED TO EASE INSERTION.
3. DISTANCE BETWEEN LEADS INCLUDING DAM BAR PROTRUSIONS TO BE .005 INCH MINIMUM.
4. DATUM PLANE COINCIDENT WITH THE BOTTOM OF LEAD, WHERE LEAD EXITS BODY.

SSOP-16L

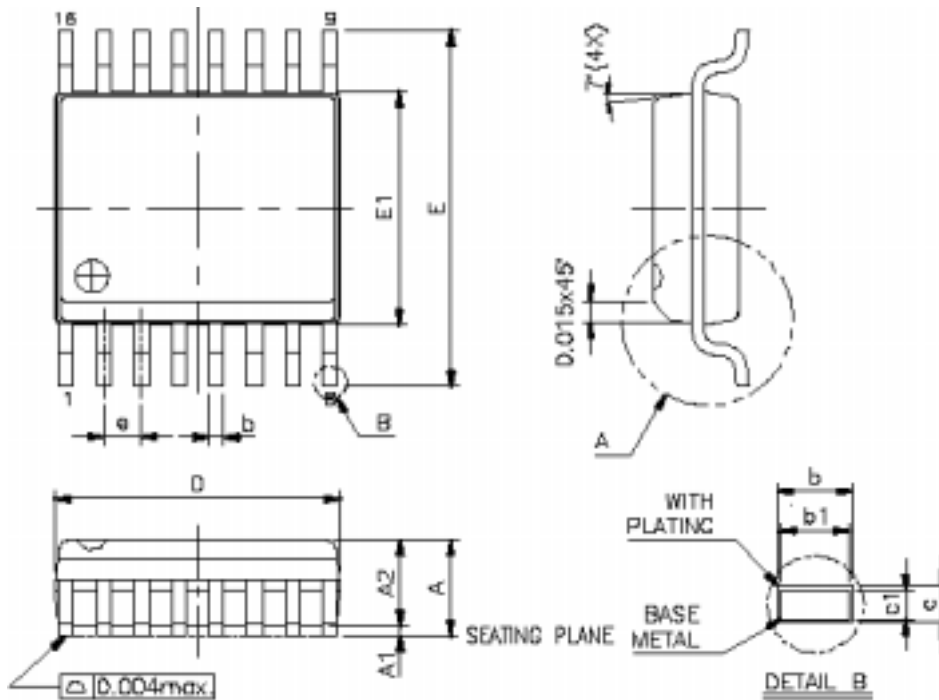

| SYMBOLS | MIN. | MAX. |
|---------|-------------|-------|
| A | 0.053 | 0.069 |
| A1 | 0.004 | 0.010 |
| A2 | - | 0.059 |
| b | 0.008 | 0.012 |
| b1 | 0.008 | 0.011 |
| c | 0.007 | 0.010 |
| c1 | 0.007 | 0.009 |
| D | 0.189 | 0.197 |
| E | 0.228 | 0.244 |
| E1 | 0.150 | 0.157 |
| L | 0.016 | 0.050 |
| e | 0.025 Basic | |
| ° | 0 | 8 |

UNIT: INCH

NOTES:

1. JEDEC OUTLINE: MO-137 AB
2. "D", DIMENSIONS DO NOT INCLUDE MOLD FLASH OR PROTRUSIONS. MOLD FLASH OR PROTRUSIONS SHALL NOT EXCEED .15mm(006in).
3. "E", DIMENSIONS DO NOT INCLUDE MOLD FLASH OR PROTRUSIONS. MOLD FLASH OR PROTRUSIONS SHALL NOT EXCEED .25mm(010in) PER SIDE.
4. DATUM PLANE COINCIDENT WITH THE BOTTOM OF LEAD, WHERE LEAD EXITS BODY.

SOP16-L(EP)

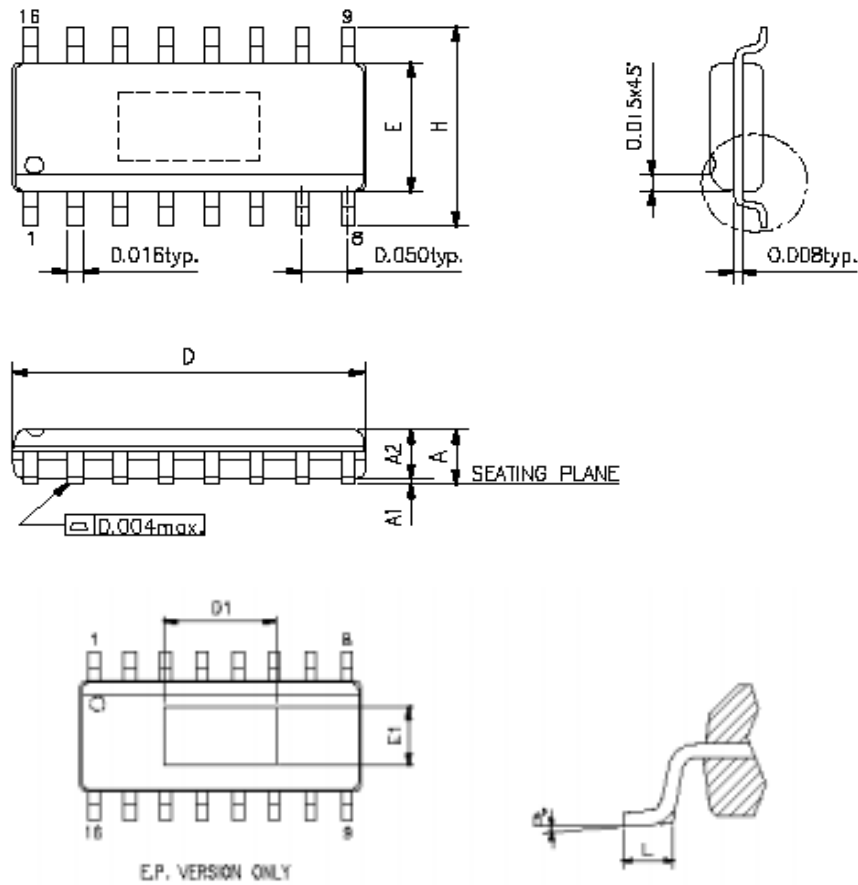

| SYMBOLS | MIN | MAX |
|---------|-------|-------|
| A | 0.053 | 0.069 |
| A1 | 0.004 | 0.010 |
| D | 0.386 | 0.394 |
| E | 0.150 | 0.157 |
| H | 0.228 | 0.244 |
| L | 0.016 | 0.050 |
| ° | 0 | 8 |

| PAD SIZE | E1 | D1 |
|----------|-----------|-----------|
| A | 0.086 REF | 0.162 REF |

UNIT:INCH

NOTE:

1. DIMENSIONS "D" DOES NOT INCLUDE MOLD FLASH,PROTRUSIONS OR GATE BURRS.MOLD FLASH,PROTRUSIONS AND GATE BURRS SHALL NOT EXCEED .15mm (.006in) PER SIDE
2. DIMENSIONS "E" DOES NOT INCLUDE INTER-LEAD FLASH,OR PROTRUSIONS.
3. NTER-LEAD FLASH AND PROTRUSIONS SHALL NOT EXCEED .25mm (.0.10in) PER SIDE.

PACKING SPECIFICATIONS

BOX DIMENSION

TUBE INSIDE BOX AND CARTON

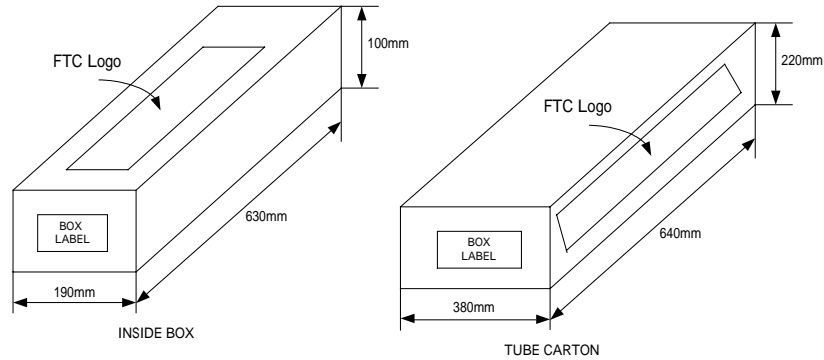

TAPE AND REEL INSIDE BOX AND CARTON

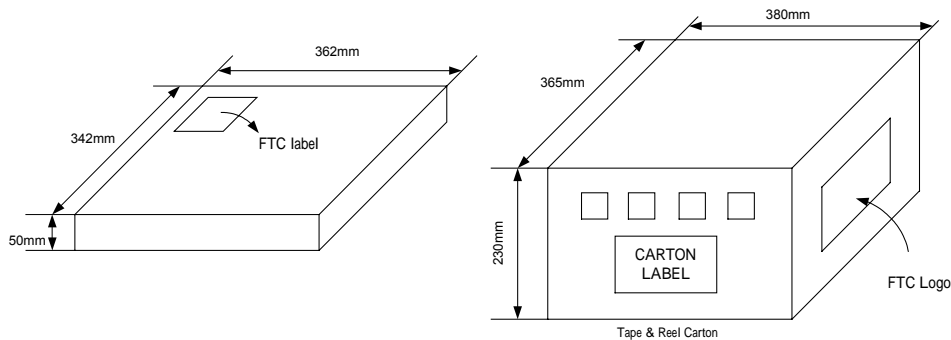

PACKING QUANTITY SPECIFICATIONS

| | |
|-------------------------|-------------------------|
| 50 EA/TUBE | 2500 EA / REEL |
| 50 TUBES / INSIDE BOX | 4 INSIDE BOXES / CARTON |
| 4 INSIDE BOXES / CARTON | |

LABEL SPECIFICATIONS

TAPPING & REEL

| | |
|--|-------------|
| Feeling Technology Corp. | |
| Product | FP5453DR-LF |
| Lot No | A3311C62-L |
| D/C | 4Xx-XXL |
| Q'ty | |
| <div style="border: 1px solid black; padding: 2px; display: inline-block;"> 無鉛 Lead Free </div> | |

CARTON

| | |
|--|--|
| Feeling Technology Corp. | |
| Product Type: FP5453DR-LF | |
| Lot No: A3311C62-L | |
| Date Code: 4Xx-XXL | |
| Package Type: SOP-8L | |
| Marking Type: Laser | |
| Total Q'ty: 10,000 | |
| <div style="border: 1px solid black; padding: 2px; display: inline-block;"> 無鉛 Lead Free </div> | |

SSOP16

CARRIER TAPE DIMENSIONS

| APPLICATION | W | P | E | F | D | D ₁ |
|-------------|----------|---------|----------|----------|---------------------|----------------------|
| SSOP16 | 12.0±0.3 | 8.0±0.1 | 1.75±0.1 | 5.5±0.05 | 1.5 ^{+0.1} | 1.5 ^{+0.25} |

| APPLICATION | P ₀ | P ₁ | A ₀ | B ₀ | K ₀ | t |
|-------------|----------------|----------------|----------------|----------------|----------------|-----------|
| SSOP16 | 4.0±0.1 | 2.0±0.05 | 6.5±0.1 | 10.3±0.1 | 2.1±0.1 | 0.30±0.05 |

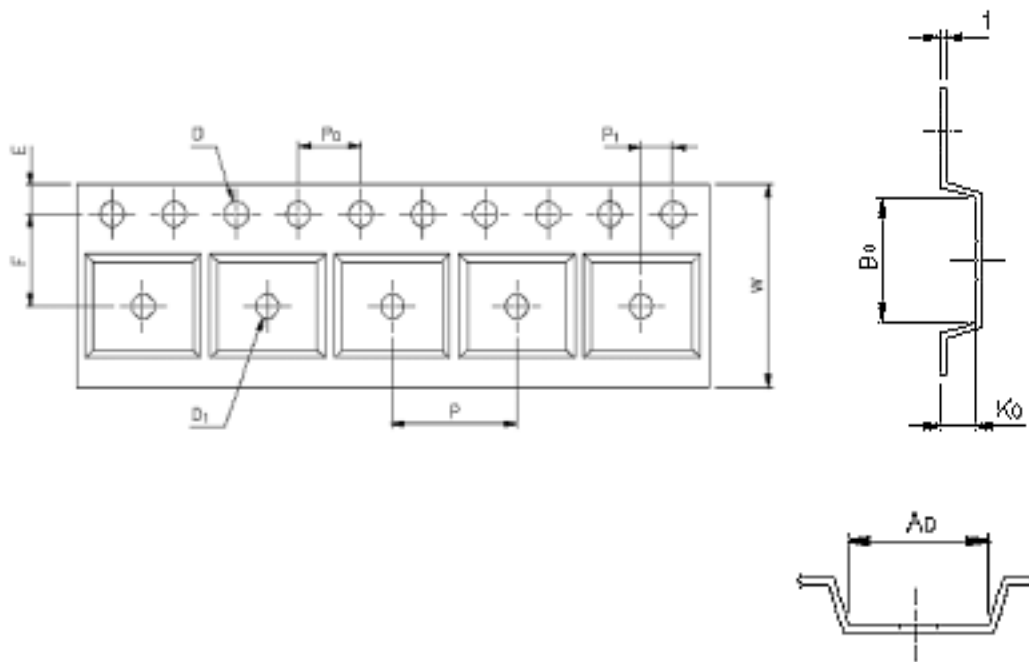

REEL DIMENSIONS

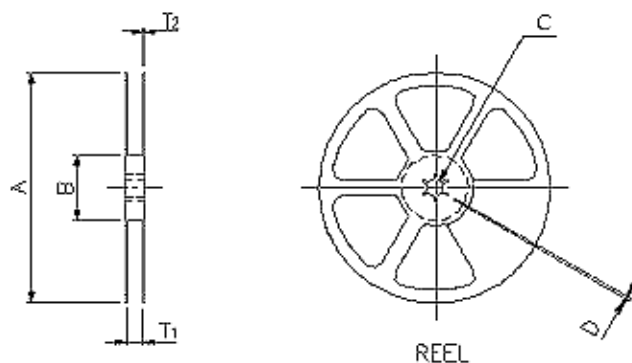

| APPLICATION | MATERIAL | A | B | C | D | T1 | T2 |
|-------------|--------------|-----|----|------------------------|----------|------|------|
| SSOP16 | PLASTIC REEL | 330 | 62 | 12.75 ^{+0.15} | 2.0±0.15 | 12.4 | 16.8 |