

**BUCK/BOOST PWM CONTROL IC
WITH SCP/DTC FUNCTION****GENERAL DESCRIPTION**

The **FP5462**, a 1-chip composed of totem-pole output stage pulse-width-modulation control circuits with two error amplifiers and dead-time comparators (DTC), the **FP5462** contains a 2.5V precision voltage reference regulator, under-voltage lockout circuit (UVLO), short circuit protection circuit (SCP), applied to offer space and low cost in many applications such as the DC/DC converter.

Using few external components, **FP5462**, a high performance integrated IC, is designed for a control circuit. The circuit diagram of the typical application example is as below.

FEATURES

- Fixed Reference Voltage: 2.5V
- Reference Voltage Precision: 1%
- Totem-pole output stage
- Low quiescent supply current under 3.5mA
- Wide operating voltage range: 3.6~40V
- Variable dead-time control (DTC)
- UVLO protection function
- SCP protection function (threshold voltage: 1.3V)
- Oscillator Frequency: Max. 500KHz
- Package: PDIP16/SOP16/SSOP16

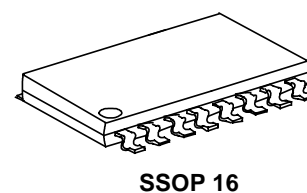
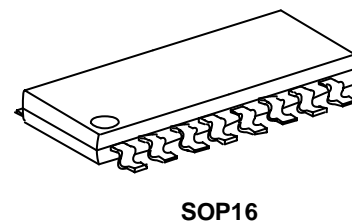
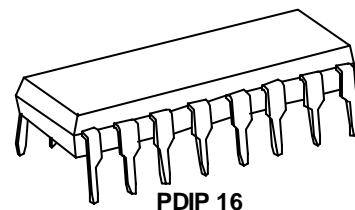
**TYPICAL APPLICATION**

- DC/DC converters for video cameras and TFT LCD monitor etc.
- 1-ch Boost/1-ch Buck Topology Converter

FUNCTIONAL BLOCK DIAGRAM

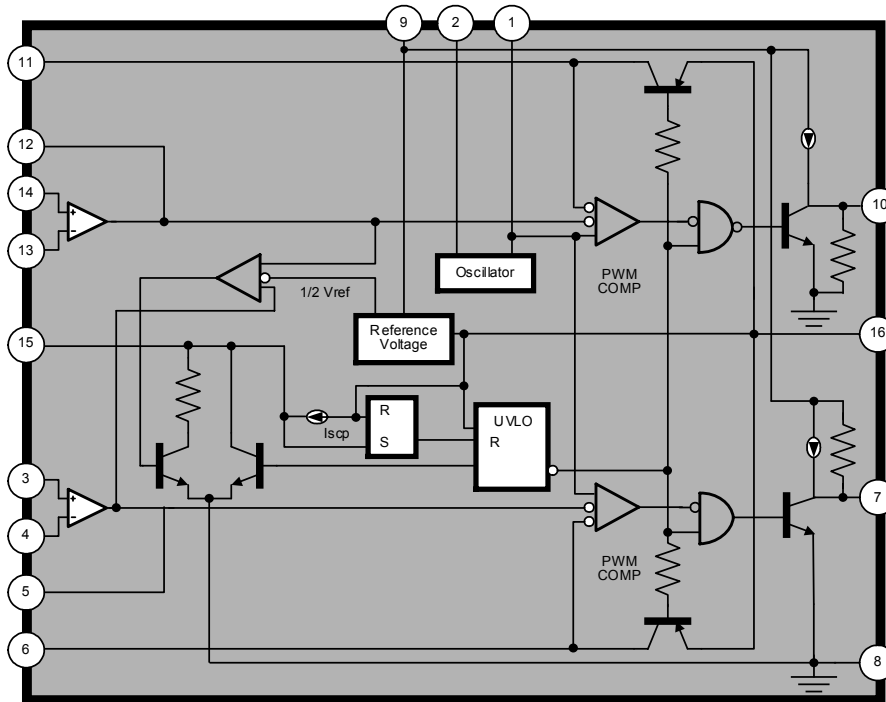

MARK VIEW

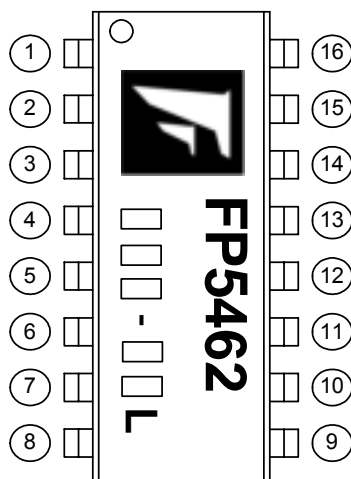

PIN DESCRIPTION

NAME	NO.	STATUS	DESCRIPTION
CT	1	I	Connect a Capacitor for Oscillator
RT	2	I	Connect a Resistor for Oscillator
EA1+	3	I	Error Amplifier 1 Non-inverting Input
EA1-	4	I	Error Amplifier 1 Inverting Input
FB1	5	O	Error Amplifier 1 Feedback Output
DTC1	6	I	Output 1 Dead-Time Comparator
OUT1	7	O	Totem-pole Output 1
GND	8	P	IC Ground
VCC	9	P	IC Power Supply
OUT2	10	O	Totem-pole Output 2
DTC2	11	I	Output 2 Dead-Time Comparator
FB2	12	O	Error Amplifier 2 Feedback Output
EA2-	13	I	Error Amplifier 2 Inverting Input
EA2+	14	I	Error Amplifier 2 Non-inverting Input
SCP	15	I	Short Circuit Protection Input
VREF	16	O	2.5V Reference Voltage Output

ORDER INFORMATION

Part Number	Operating Temperature	Package	Description
FP5462P-LF	-20°C ~ +85°C	PDIP16	Tube
FP5462D-LF	-20°C ~ +85°C	SOP16	Tube
FP5462DR-LF	-20°C ~ +85°C	SOP16	Tape & Reel
FP5462R-LF	-20°C ~ +85°C	SSOP16	Tube
FP5462RR-LF	-20°C ~ +85°C	SSOP16	Tape & Reel

IC DATE CODE DISTINGUISH

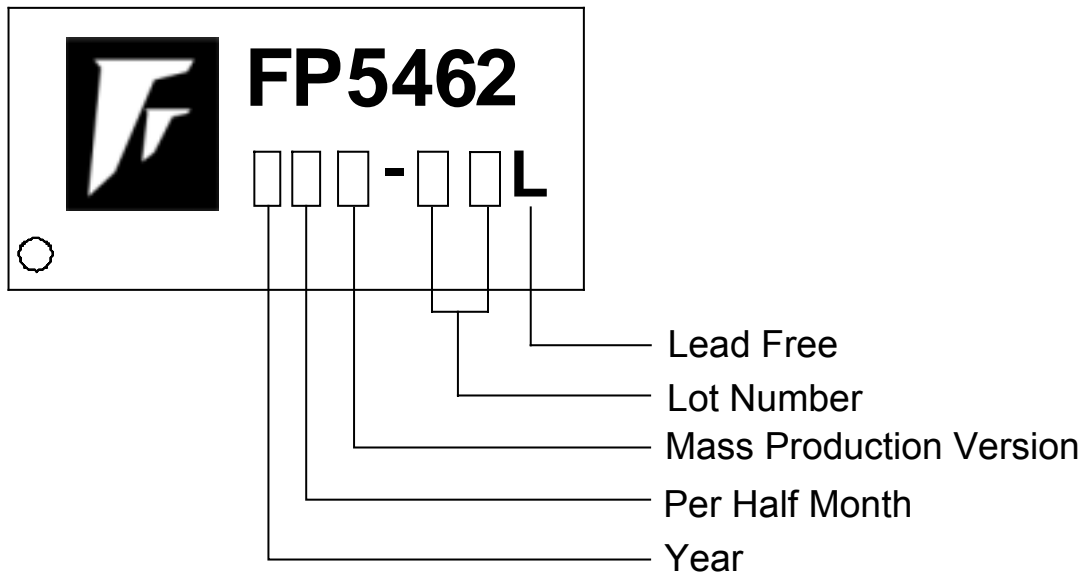

FOR EXAMPLE:

January A (Front Half Month), B (Last Half Month)
 February C, D
 March E, F -----And so on

Lot Number is the last two numbers

For Example:

A3311C62
 ↳ Lot Number

ABSOLUTE MAXIMUM RATINGS

Supply Voltage (Vcc) -----	+35V
Differential Input Voltage (V _{id}) -----	+20V
Output Current (I _o) -----	+150mA
Maximum Junction Temperature (T _j) -----	+150°C
Thermal Resistance Junction to Ambient	
PDIP16 package -----	125°C /W
SOP16 package -----	150°C /W
SSOP16 package -----	220°C /W
Power Dissipation	
DIP16 package	
Ta=25 -----	1000mW
Ta=70 -----	640mW
SOP16 package	
Ta=25 -----	830mW
Ta=70 -----	530mW
SSOP16 package	
Ta=25 -----	570mW
Ta=70 -----	360mW
Operating Temperature Range -----	-20°C 85°C
Storage Temperature Range -----	-65°C 150°C
Lead Temperature (soldering, 10 sec) -----	+260°C

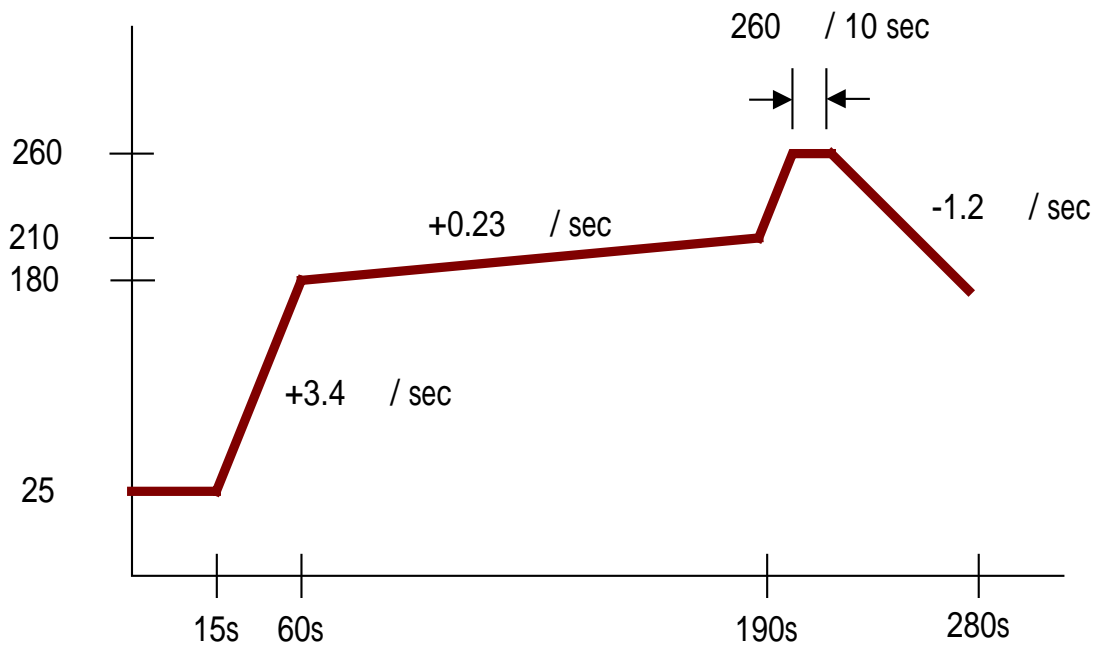

DC ELECTRICAL CHARACTERISTICS

Electrical characteristics over recommended operating free-air temperature range, $V_{CC}=6V$, $f=200KHz$ (unless otherwise noted)

Reference section

PARAMETER	SYMBOL	TEST CONDITIONS	MIN	TYP	MAX	UNIT
Output voltage (pin 16)	V_{REF}	$I_O=1mA$	2.475	2.5	2.525	V
Output voltage change with Temperature		$T_A=-20^{\circ}C$ to $25^{\circ}C$		-0.1%	$\pm 1\%$	
		$T_A=25^{\circ}C$ to $85^{\circ}C$		-0.2%	$\pm 1\%$	
Input voltage regulation	$\Delta V_{REF}/V_{REF}$	$V_{CC}=3.6V \sim 30V$		2	12.5	mV
Output voltage regulation	$\Delta V_{REF}/V_{REF}$	$I_O = 0.1mA$ to $1 mA$		1	7.5	mV
Short-circuit output current	I_{SHORT}	$V_O=0$	3	10	30	mA

Undervoltage lockout section

PARAMETER	SYMBOL	TEST CONDITIONS	MIN	TYP	MAX	UNIT
Upper threshold voltage(V_{CC})	V_{UPPER}	$I_{O(REF)} = 0.1 mA$, $T_A=25^{\circ}C$		2.72		V
Lower threshold voltage(V_{CC})	V_{LOW}			2.6		V
Hysteresis (V_{CC})	V_{HYS}		80	120		mV
Reset threshold voltage(V_{CC})	V_{RESET}		1.5	1.9		V

Short-circuit protection control section

PARAMETER	SYMBOL	TEST CONDITIONS	MIN	TYP	MAX	UNIT
Input threshold voltage (SCP)	V_{TH}	$T_A = 25^{\circ}C$	1.2	1.3	1.5	V
Standby voltage (SCP)	$V_{STANDBY}$	No pullup	220	265	300	mV
Latched input voltage (SCP)	V_{LATCH}	No pullup		220	280	mV
Input (source) current	I_{SOURCE}	$V_I=0.7V$, $T_A=25^{\circ}C$	-1.	-2.0	-2.5	μA
Comparator threshold voltage (FEEDBACK)	$V_{COMP(TH)}$			1.30		V

Oscillator section

PARAMETER	SYMBOL	TEST CONDITIONS	MIN	TYP	MAX	UNIT
Frequency	f	$C_T=330pF, R_T=10K$		200		KHz
Standard deviation of frequency	Δf	$C_T=330pF, R_T=10K$		10%		
Frequency change with voltage	$\Delta f/\Delta V$	$V_{CC}=3.6V$ to $30V$		1%		
Frequency change with Temperature	$\Delta f/\Delta T$	$T_A=-20^{\circ}C$ to $25^{\circ}C$		-0.4%	$\pm 2\%$	
		$T_A=25^{\circ}C$ to $85^{\circ}C$		-0.2%	$\pm 2\%$	

DC ELECTRICAL CHARACTERISTICS (Cont.)

Electrical characteristics over recommended operating free-air temperature range, $V_{CC}=6V$, $f=200KHz$ (unless otherwise noted)

Dead-time control section

PARAMETER	SYMBOL	TEST CONDITIONS	MIN	TYP	MAX	UNIT
Input bias current (DTC)	I_{BIAS}				1	μA
Latch mode (source) current(DTC)	I_{SOURCE}	$T_A=25^{\circ}C$	-80	-200		μA
Latched input voltage (DTC)	V_{LATCH}	$I_O=40\mu A$	2.3			V
Input threshold voltage at $f=10kHz$ (DTC)	V_{TH}	Zero duty cycle		2.05	2.25	V
		Maximum duty cycle	1.2	1.45		

Error amplifier section

PARAMETER	SYMBOL	TEST CONDITIONS	MIN	TYP	MAX	UNIT
Input offset voltage	V_{IO}	$V_O(FeEDBACK)=1.25V$			± 6	mV
Input offset current	I_{IO}	$V_O(FeEDBACK)=1.25V$			± 100	nA
Input bias current	I_{BIAS}	$V_O(FeEDBACK)=1.25V$		160	500	nA
Common-mode input voltage range	V_{ICM}	$V_{CC}=3.6V$ to 30 V	0.3		1.6	V
Open-loop voltage amplification	A_{VO}	$R_F=200K\Omega$	70	80		dB
Unity-gain bandwidth	BW			1.5		MHz
Common-mode rejection ratio	CMRR		60	80		dB
Positive output voltage swing	V_{POS}		$V_{ref}-0.3$			V
Negative output voltage swing	V_{NEG}				1	V
Output (sink) current (FEEDBACK)	I_{SINK}	$V_{ID}=-0.1V, V_O=1.25V$	1	4.0		mA
Output (source) current (FEEDBACK)	I_{SOURCE}	$V_{ID}=0.1V, V_O=1.25V$	-45	-90		μA

DC ELECTRICAL CHARACTERISTICS (Cont.)

Electrical characteristics over recommended operating free-air temperature range, $V_{CC}=6V$, $f=200KHz$ (unless otherwise noted)

Output section

PARAMETER	SYMBOL	TEST CONDITIONS	MIN	TYP	MAX	UNIT
Vout Low Voltage	V_{OL}	$I_{SINK}=20mA$		0.8	1.2	V
		$I_{SINK}=130mA$ $V_{CC}=15V$		1.6	2.2	
Vout High Voltage	V_{OH}	$I_{SOURCE}=20mA$	4	4.5		V
		$I_{SOURCE}=130mA$ $V_{CC}=15V$	13	13.5		
Rise Time	t_R	$T_J=25^{\circ}C, C_L=1nF$		80	120	nS
Fall Time	t_F	$T_J=25^{\circ}C, C_L=1nF$		30	60	nS

PWM comparator section

PARAMETER	SYMBOL	TEST CONDITIONS	MIN	TYP	MAX	UNIT
Input threshold voltage at $f=10kHz$ (FEEDBACK)	V_{TH}	Zero duty cycle		2.05	2.25	V
		Maximum duty cycle	1.2	1.45		

Total device

PARAMETER	SYMBOL	TEST CONDITIONS	MIN	TYP	MAX	UNIT
Standby supply current	$I_{STANDBY}$	Off-state		2.3	3.0	mA
Average supply current	I_{AVE}	$R_T=10K$		2.8	3.5	mA

TYPICAL CHATAACTERISTICS

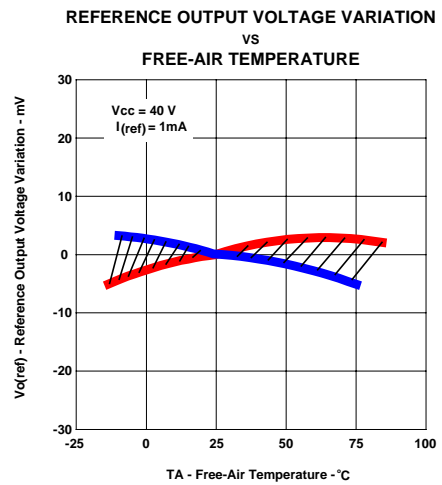
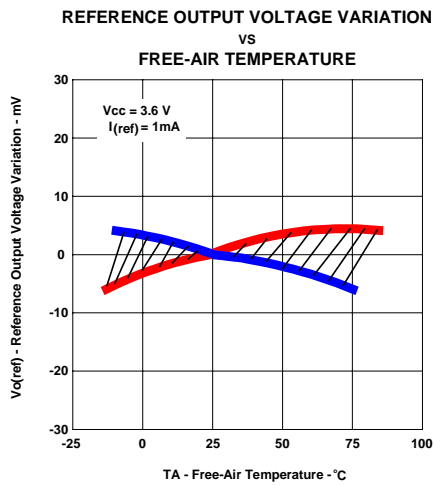
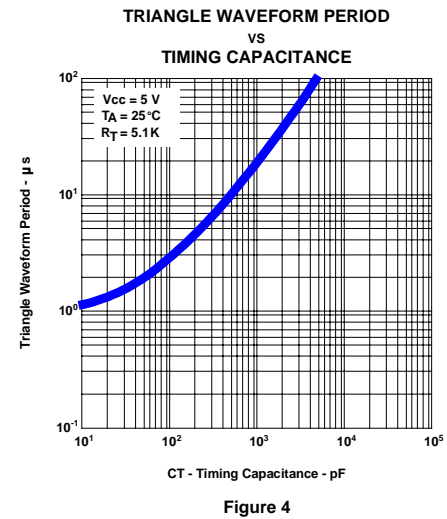
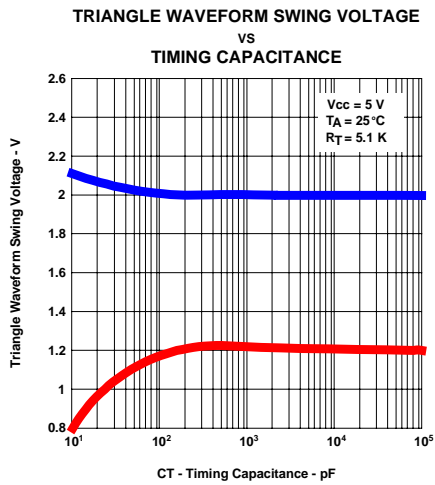
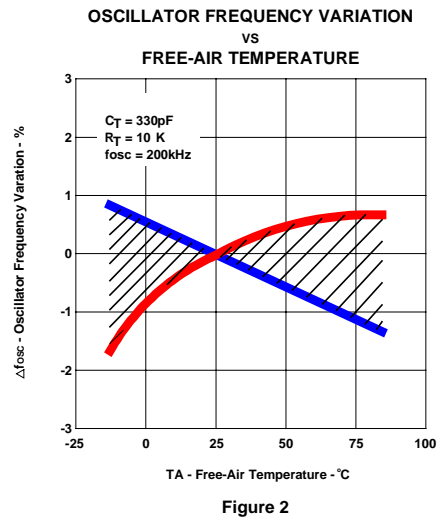
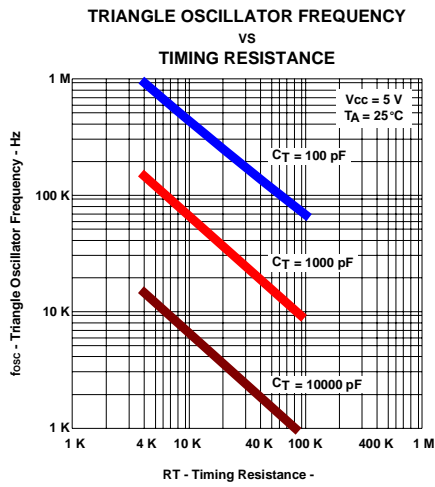

TYPICAL CHATACTERISTICS (Cont.)

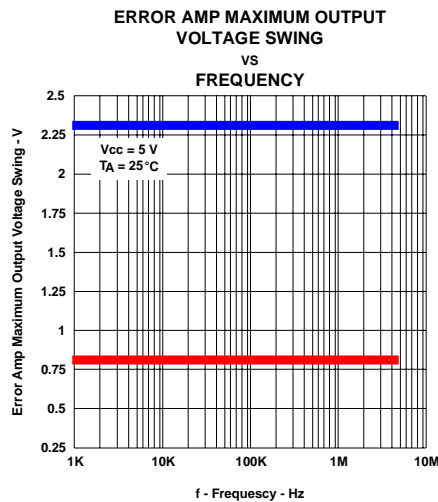
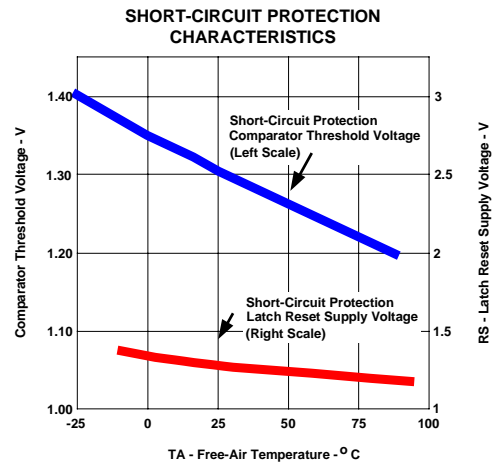
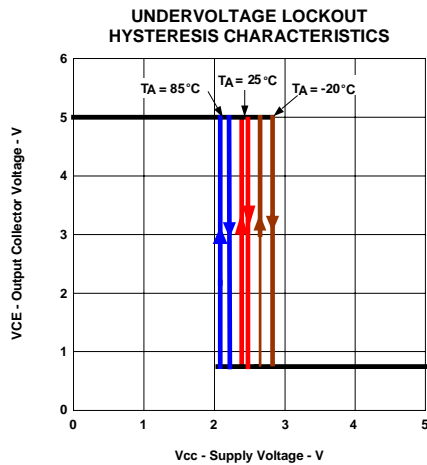
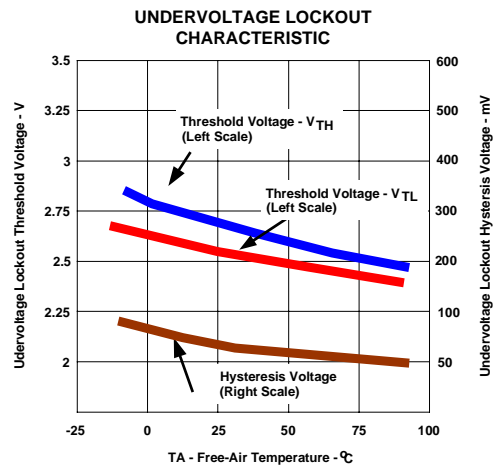
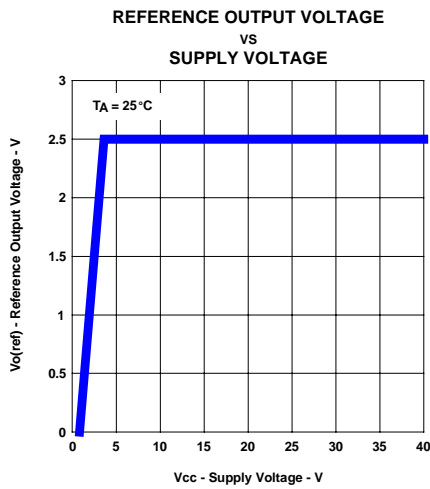

TYPICAL CHATACTERISTICS (Cont.)

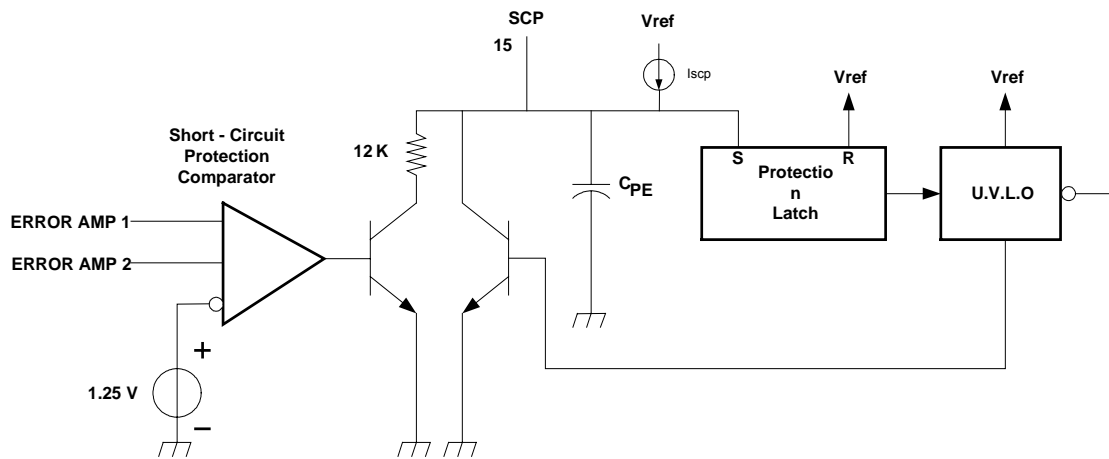
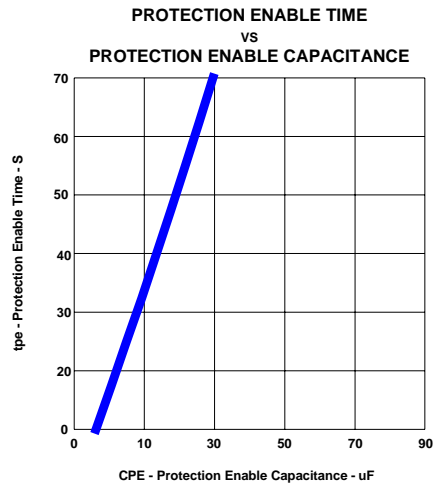
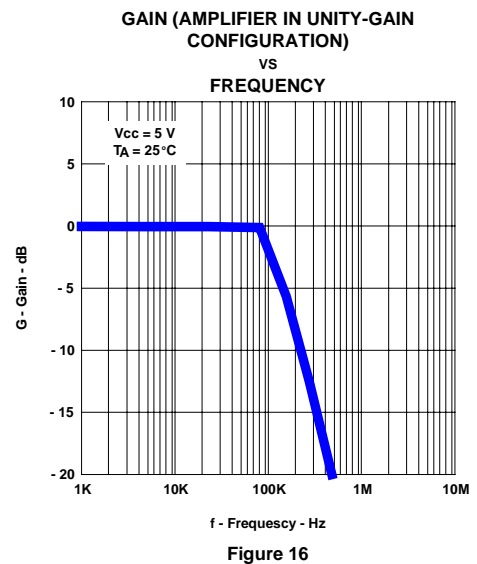
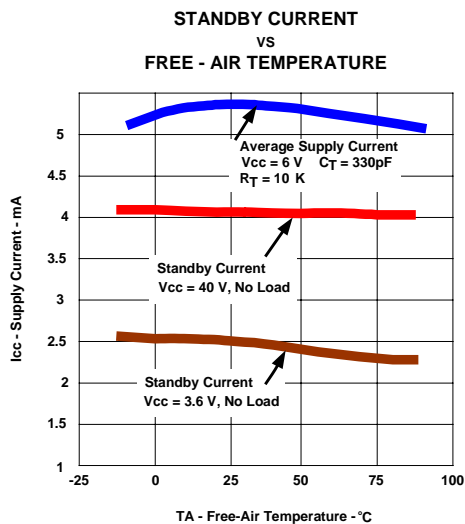
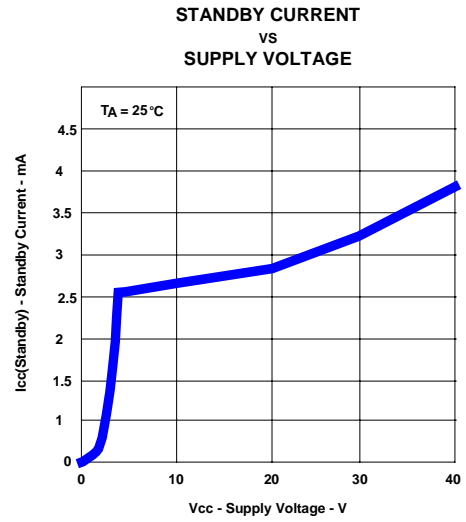
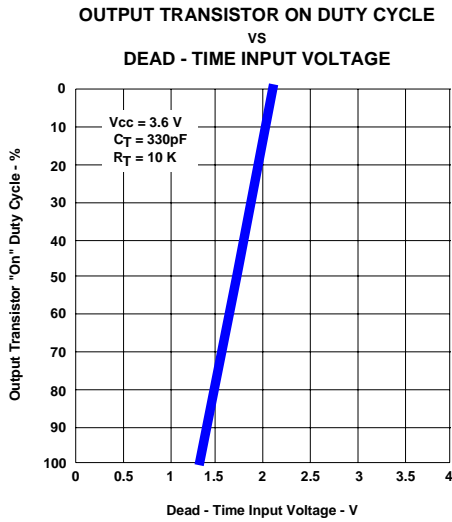

Figure 12

TYPICAL CHATACTERISTICS (Cont.)



FP5462 TIMING WAVEFORM

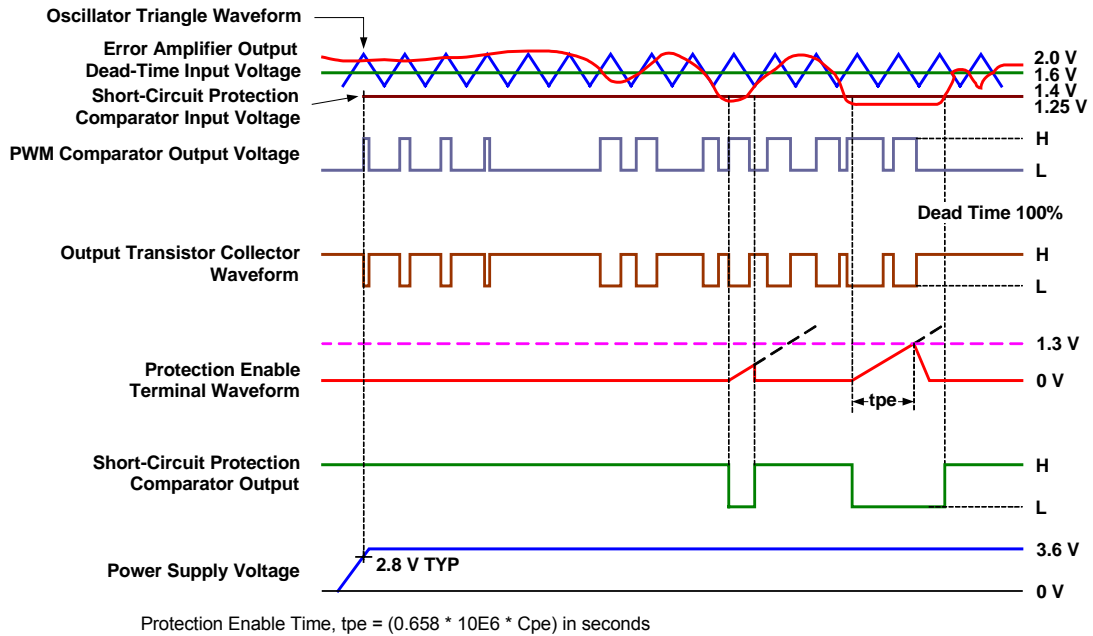

Figure 17 FP5462 CH1 Timing Diagram

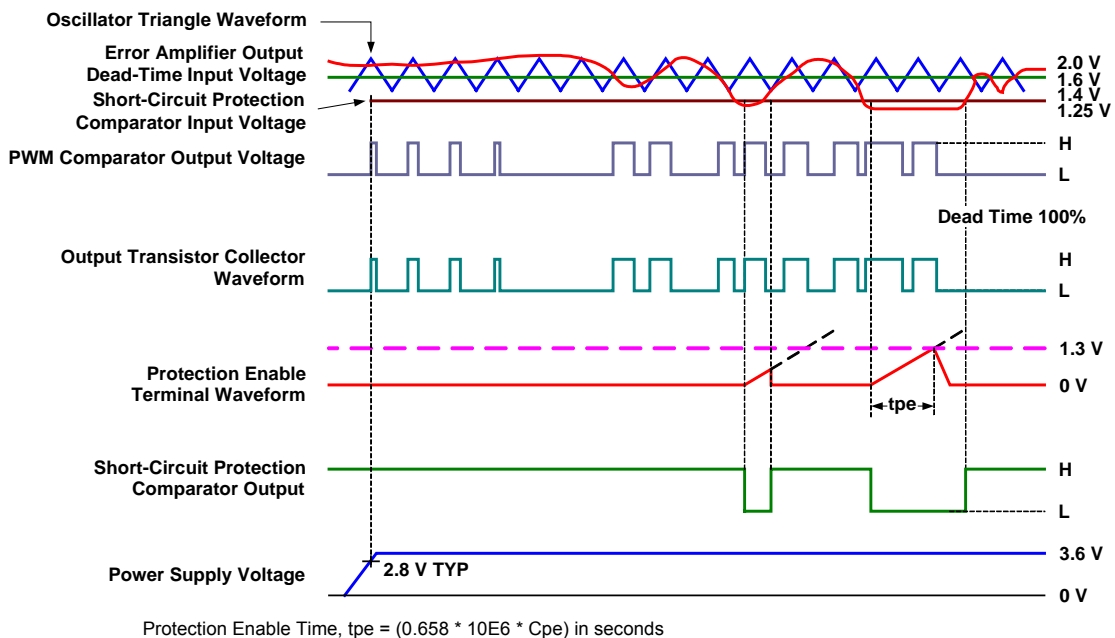

Figure 18 FP5462 CH2 Timing Diagram

DETAILED DESCRIPTION

Voltage Reference

FP5462 has an internal 2.5V reference regulator using for the internal circuits' voltage bias, and another function is using with the resistive divider connecting to the IC error amplifier inverting input for output feedback reference(see Fig 19).

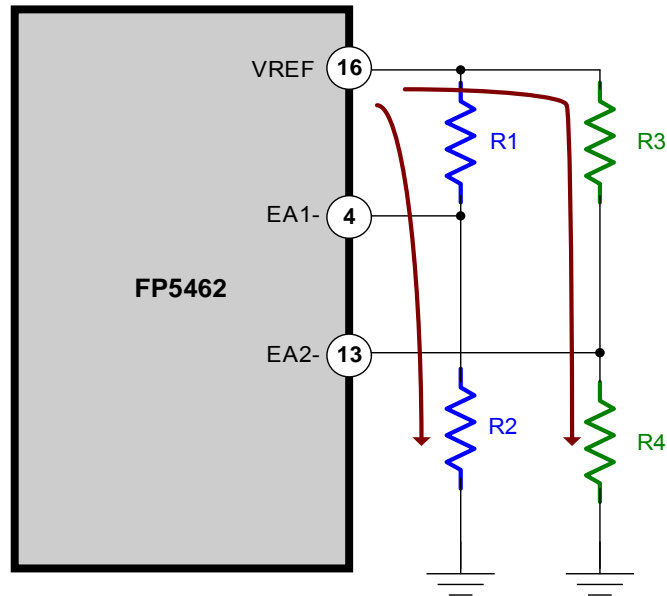

Figure 19 Reference and error amplifiers with resistive dividers

The error amplifier inverting input (EA1- or EA2-) reference voltage formulas are shown as below:

$$V_{EA1-} = VREF(2.5V) \times \frac{R2}{R1 + R2}$$

$$V_{EA2-} = VREF(2.5V) \times \frac{R4}{R3 + R4}$$

And we will discuss both relationship of the output voltage and error amplifier reference voltage next page.

Error Amplifier

The error amplifiers of **FP5462** compare the feedback voltage from the resistive dividers of dc-dc converter output to the reference bias(see Fig 20), and generate the error signal for the PWM comparator, the relation formulas are shown as below:

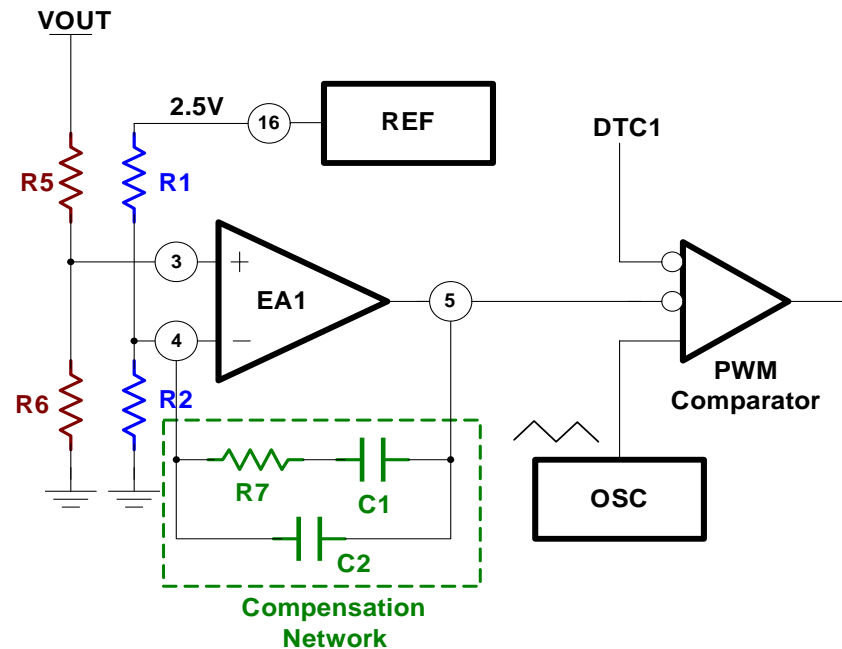

Figure 20 Error amplifier with Feedback/Compensation Circuits

The Buck converter output voltage:

$$V_{OUT} = \left(1 + \frac{R5}{R6}\right) \times \left(\frac{R2}{R1 + R2}\right) \times 2.5V$$

Error Amplifier Gain:

$$A_v = 1 + \frac{1 + sR7C1}{sRi(C1 + C2)(1 + sR7C2)} \quad , Ri = R1 // R2$$

Error Amplifier Zero and Pole Frequency:

$$F_z = \frac{1}{2\pi R7C1} \quad , \quad F_p = \frac{1}{2\pi R7C2}$$

Oscillator/PWM Comparator

The oscillator frequency can be decided from 20KHz to 500KHz by the resistor (RT) and capacitor (CT) which are connected with pin1 and pin2 of **FP5462**, a sawtooth waveform would compare with feedback signal of the error amplifier and dead-time control voltage, the figure 21 is the relationship of oscillator, error amplifier and PWM comparator, and figure 22 is the waveforms of **FP5462**.

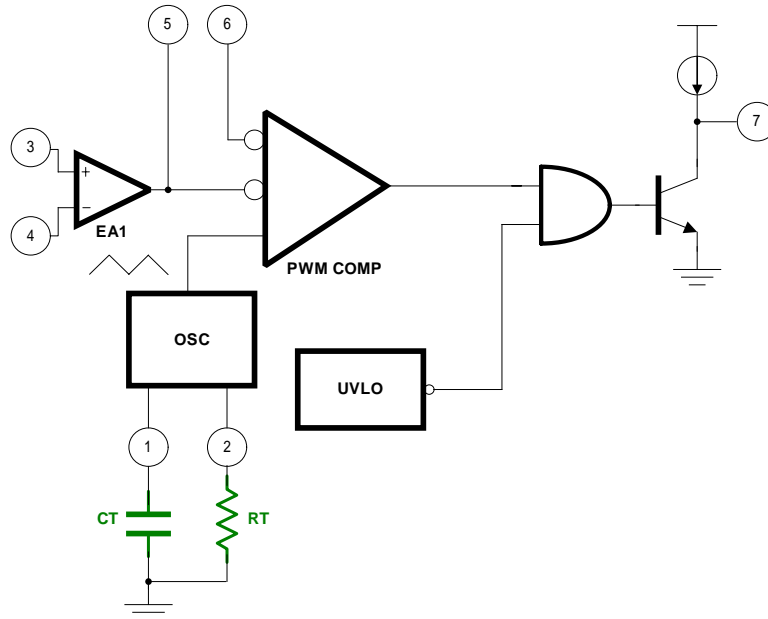

Figure 21 Oscillator/PWM Comparator with Frequency RC circuits

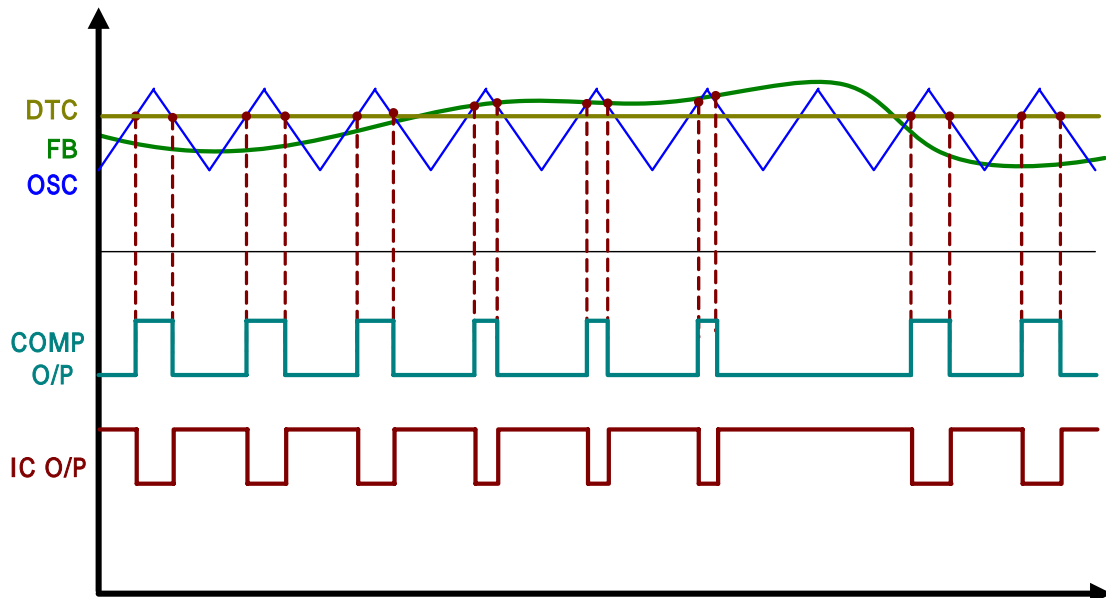

Figure 22 FP5462 Timing Waveforms

The relationship of oscillator waveform and dead-time voltage is shown below (see Fig 23):

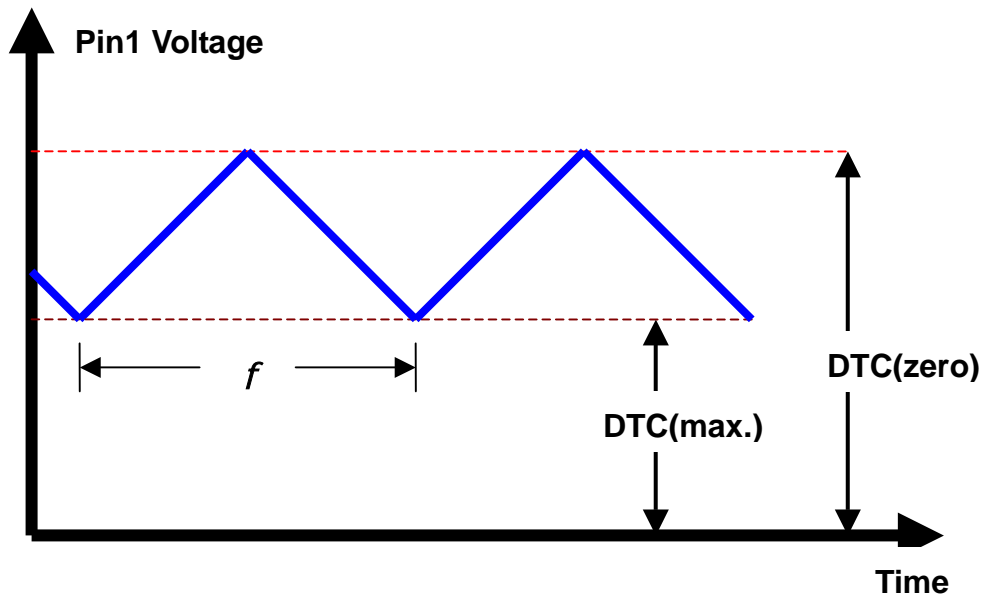

Figure 23 Oscillator Frequency with DTC voltage

The oscillator frequency calculation formula is shown as below:

$$f = \frac{VT}{2 * CT * RT * (V_{zero} - V_{max.})}$$

Dead-Time Control/Soft-Start

The dead-time control (DTC) is a function for the PWM duty cycle limitation, if the DTC voltage is lower than DTC maximum voltage (typ. 1.35V), the PWM duty cycle can change to 100% cycle; and if the DTC voltage is higher than DTC zero voltage (typ. 2.05V), the PWM duty cycle should always turn-off (zero duty).

The system of DC-DC converter can use DTC function with an external RC for Power-On soft-start (see Fig 24) and a simple formula to calculate the soft-start time.

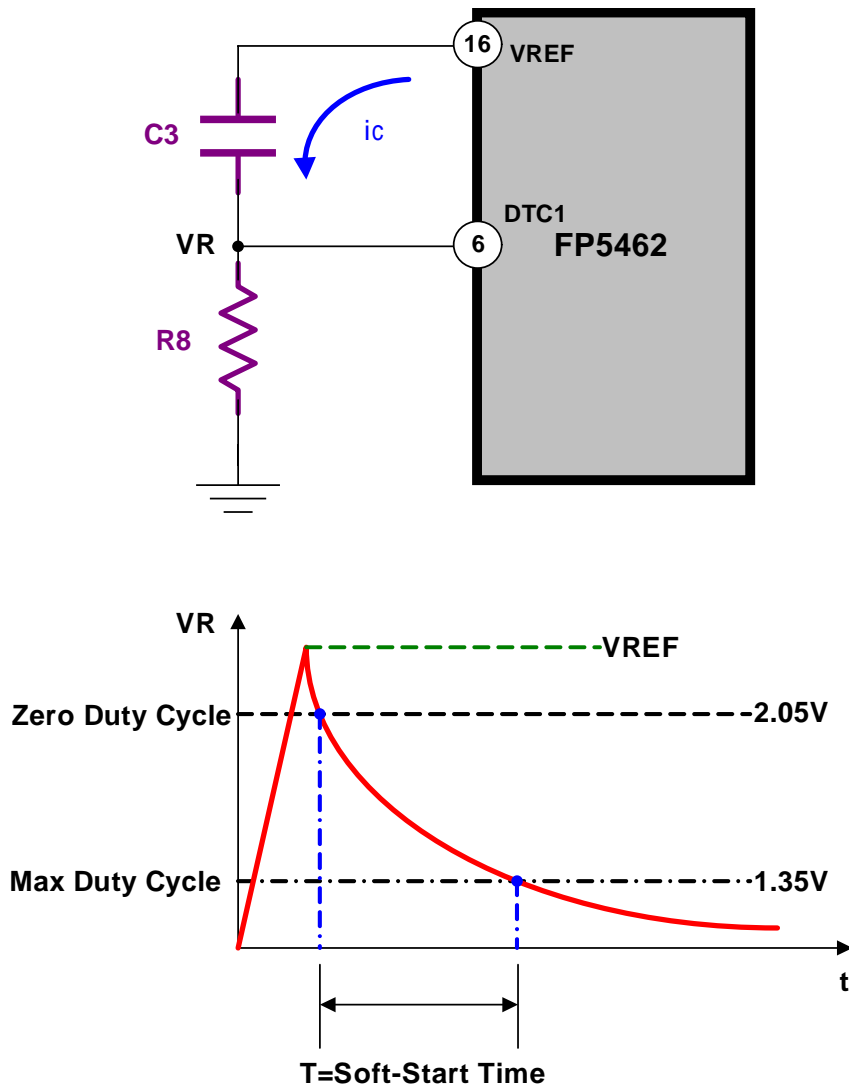

Figure 24 DTC Soft-start RC circuit and waveform

The soft-start time formula:

$$t = 0.616 * R8C3$$

Short Circuit Protection

FP5462 has a protection function when short circuit is occurred, when the DC-DC converter feedback voltage is drop a very low voltage, the error amplifier IN+ pin would also have a low feedback voltage, the output of error amplifier will generate a low voltage state to compare a 1.25V of the SCP comparator, and SCP comparator should turn-off the transistor Q1 and SCP capacitor is charged to a threshold voltage (typ. 1.3V) for latched the off state of PWM output and source the DTC current to bias a zero duty condition and reset the SCP pin voltage by Q2 transistor (see Fig 25).

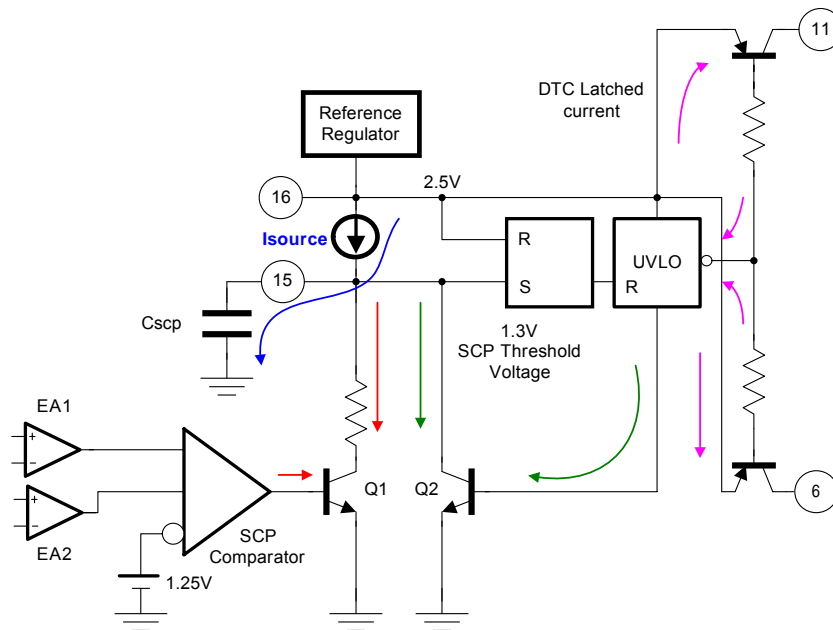

Figure 25 Internal SCP Detection/Control Circuits

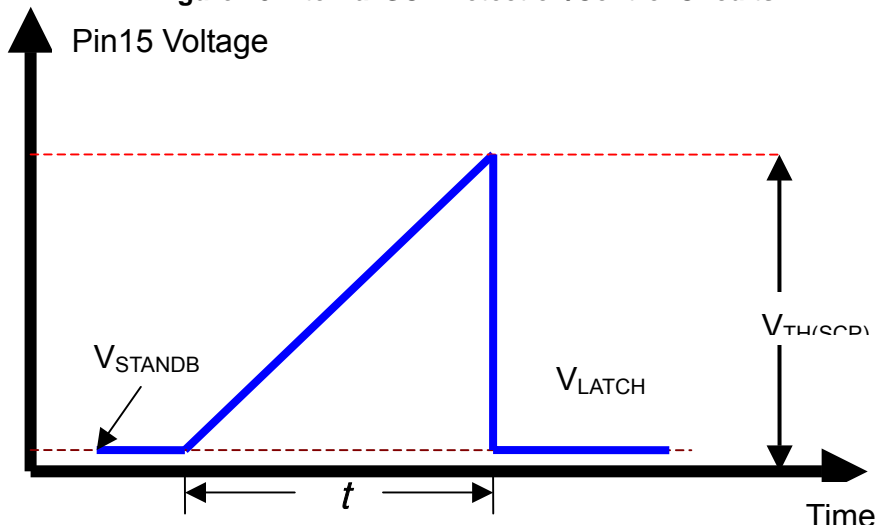

Figure 26 SCP waveform (SCP active)

The SCP time formula is:

$$t = \frac{C_{SCP} * (V_{th(scp)} - V_{sb})}{I_{source}}$$

APPLICATION NOTE

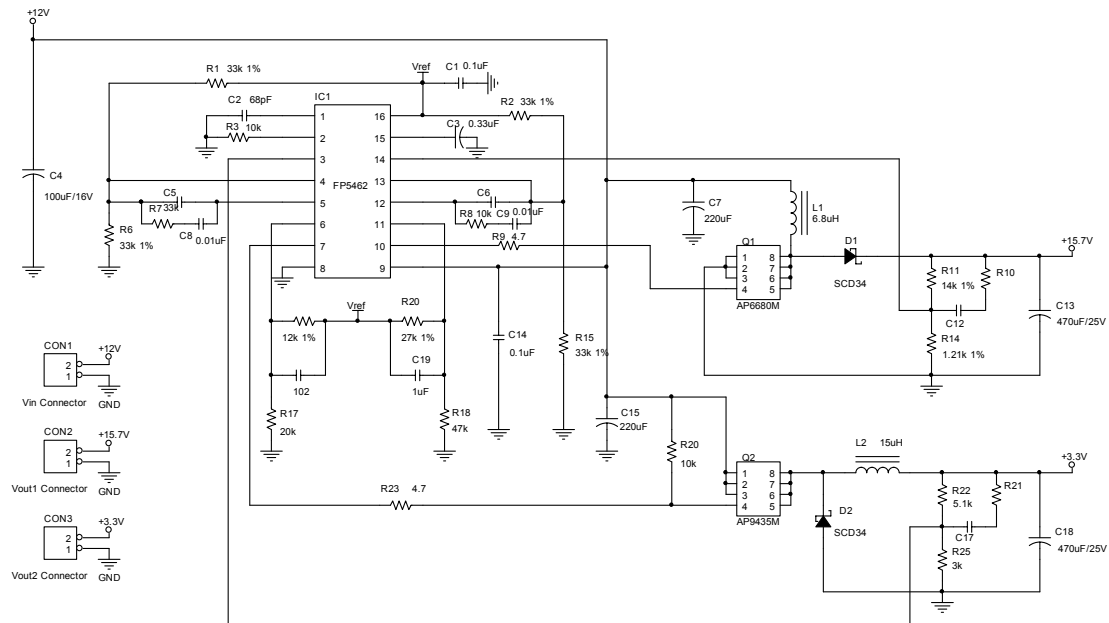

Figure 27 FP5462 Buck/Boost Regulators Application Circuits

Note

- The IN1- and IN2- is 1.25V a half of VREF voltage because R1=R6 and R2=R15.
- The R18-R20-C19 is a DTC circuits for Boost Regulator power-on.
- The R11-R14 is the boost regulator output voltage feedback resistances.
- The R22-R25 is the buck regulator output voltage feedback resistances.
- The R7-C5-C8 is the compensation circuit for error amplifier 1 of **FP5462**.
- The R8-C6-C9 is the compensation circuit for error amplifier 2 of **FP5462**.
- The R3-C2 is an external RC circuit for **FP5462** internal oscillator.
- The C3 is **FP5462** short circuit protection delay time capacitor.

PACKAGE OUTLINE

SOP16

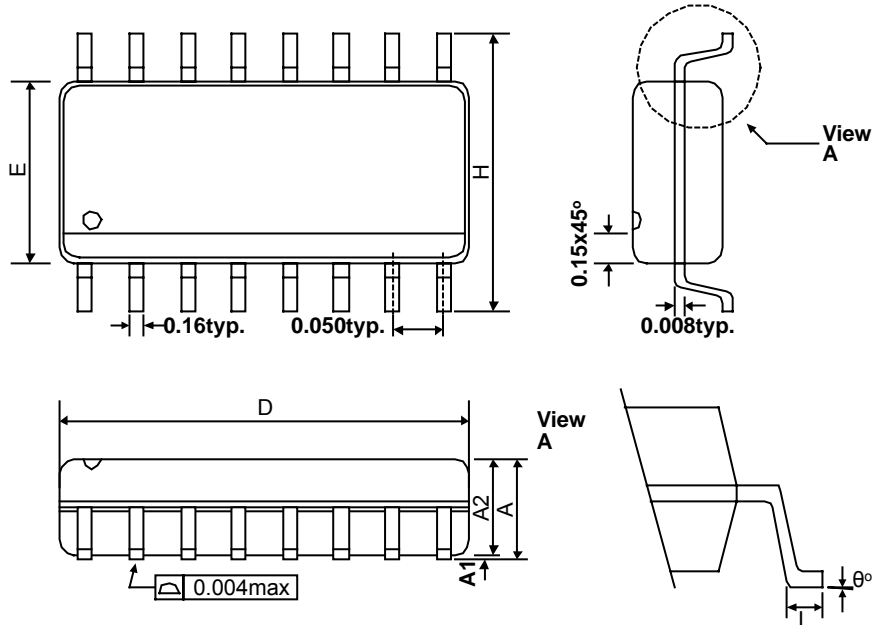

SYMBOLS	MIN	MAX
A	0.053	0.069
A1	0.004	0.010
D	0.386	0.394
E	0.150	0.157
H	0.228	0.244
L	0.016	0.050
°	0	8

NOTE:

JEDEC OUTLINE:MS-012 AC

DIMENSIONS "D" DOES NOT INCLUDE MOLD FLASH,PROTRUSIONS OR GATE BURRS.MOLD FLASH,PROTRUSIONS AND GATE BURRS SHALL NOT EXCEED .15mm (.006in) PER SIDE

DIMENSIONS "E" DOES NOT INCLUDE INTER-LEAD FLASH,OR PROTRUSIONS. INTER-LEAD FLASH AND PROTRUSIONS SHALL NOT EXCEED .25mm (.010in) PER SIDE.

PDIP16

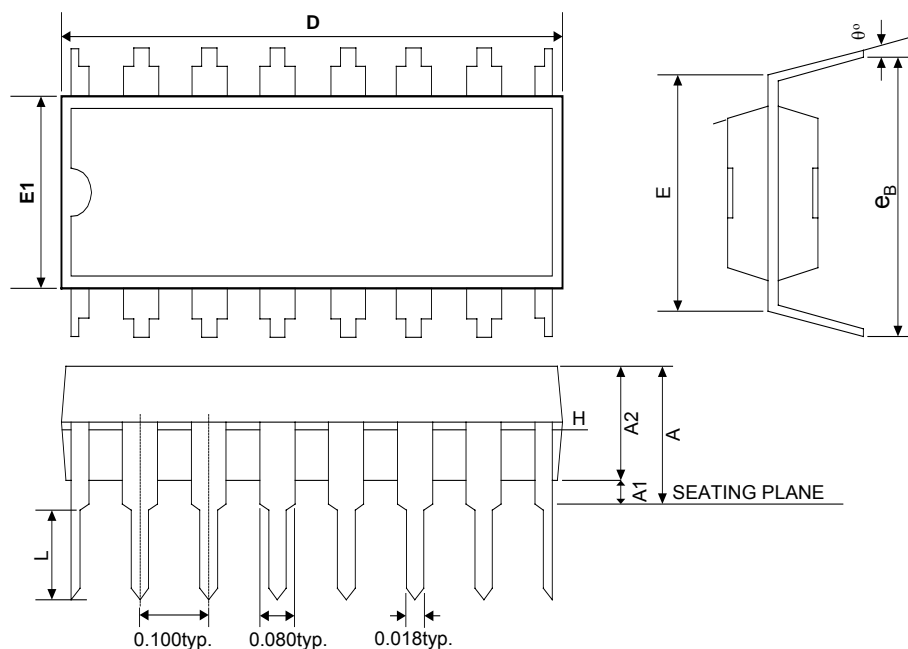

SYMBOLS	MIN.	NOR.	MAX.
A	—	—	0.210
A1	0.015	—	—
A2	0.125	0.130	0.135
D	0.735	0.755	0.775
E	0.300 BSC.		
E1	0.245	0.250	0.255
L	0.115	0.130	0.150
e _θ	0.335	0.355	0.375
°	0	7	15

NOTES:

1. JEDEC OUTLINE: MS-001 BB
2. "D", "E1" DIMENSIONS DO NOT INCLUDE MOLD FLASH OR PROTRUSIONS. MOLD FLASH OR PROTRUSIONS SHALL NOT EXCEED .010 INCH.
3. e_B IS MEASURED AT THE LEAD TIPS WITH THE LEADS UNCONSTRAINED.
4. POINTED OR ROUNDED LEAD TIPS ARE PREFERRED TO EASE INSERTION.
5. DISTANCE BETWEEN LEADS INCLUDING DAM BAR PROTRUSIONS TO BE .005 INCH MINIMUM.
6. DATUM PLANE COINCIDENT WITH THE BOTTOM OF LEAD, WHERE LEAD EXITS BODY.

SSOP16

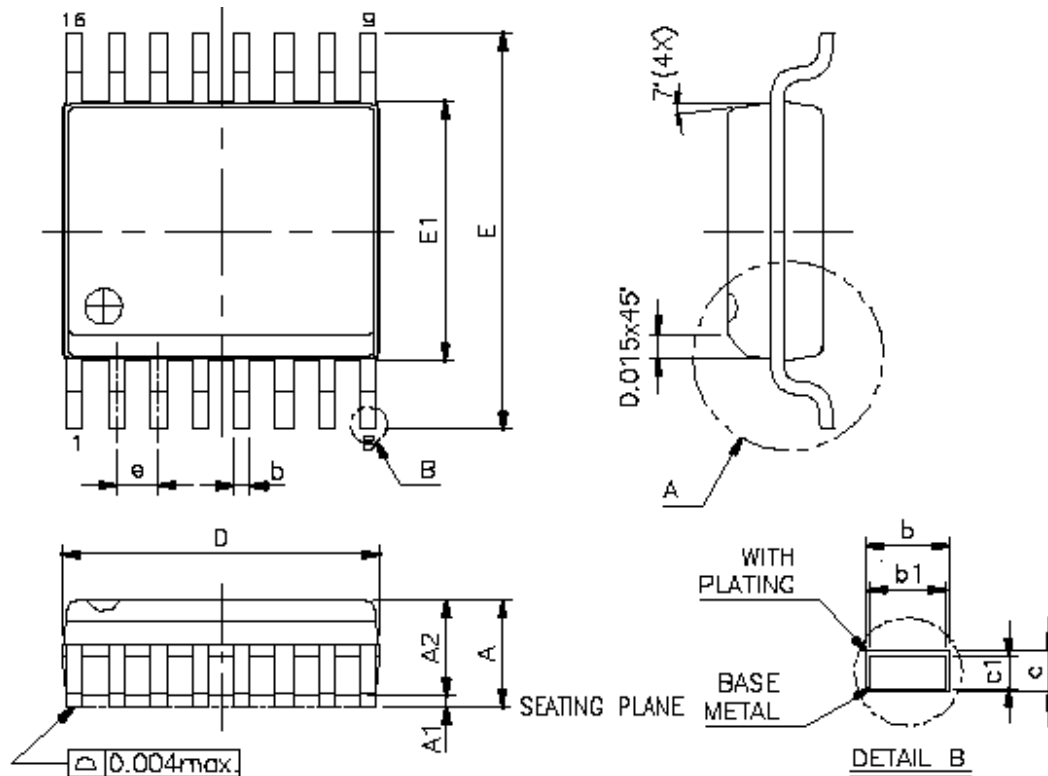

SYMBOLS	MIN.	MAX.
A	0.053	0.069
A1	0.004	0.010
A2	-	0.059
b	0.008	0.012
b1	0.008	0.011
c	0.007	0.010
c1	0.007	0.009
D	0.189	0.197
E	0.228	0.244
E1	0.150	0.157
L	0.016	0.050
e	0.025 Basic	
°	0	8

NOTES:

1. JEDEC OUTLINE: MO - 137 AB
2. DIMENSIONS "D" DOES NOT INCLUDE MOLD FLASH, PROTRUSIONS OR GATE BURRS. MOLD FLASH, PROTRUSIONS AND GATE BURRS SHALL NOT EXCEED .15mm(.006in) PER SIDE
3. DIMENSIONS "E" DOES NOT INCLUDE INTER-LEAD FLASH OR PROTRUSIONS. INTER-LEAD FLASH AND PROTRUSIONS SHALL NOT EXCEED .25mm(.010in) PER SIDE

PACKING SPECIFICATIONS

BOX DIMENSION

TUBE INSIDE BOX AND CARTON

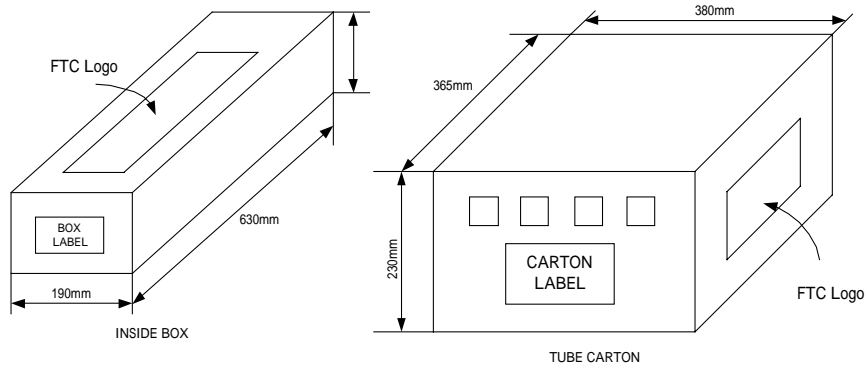

TAPE AND REEL INSIDE BOX AND CARTON

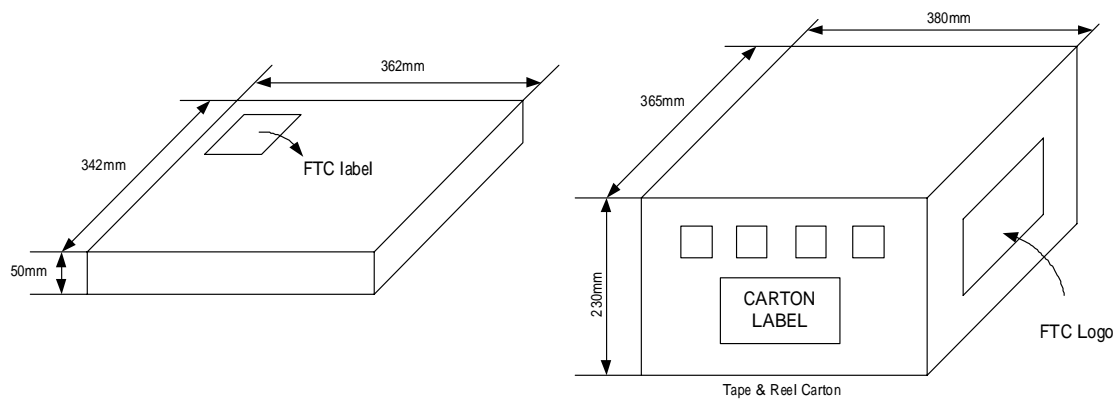

PACKING QUANTITY SPECIFICATIONS

50 EA/TUBE	2500 EA / REEL
50 TUBES / INSIDE BOX	4 INSIDE BOXES / CARTON
4 INSIDE BOXES / CARTON	

LABEL SPECIFICATIONS

TAPPING & REEL

Feeling Technology Corp.
Product FP5462
Lot No A3311C62
D/C 4Xx-XXL
Q'ty
<div style="border: 1px solid black; padding: 2px; display: inline-block;"> 無鉛 Lead Free </div>

CARTON

Feeling Technology Corp.	
Product Type: FP5462	
Lot No: A3311C62	
Date Code: 4Xx-XXL	
Package Type: SOP-16L	
Marking Type: Laser	無鉛 Lead Free
Total Q'ty: 10,000	

CARRIER TAPE DIMENSIONS

SOP16

APPLICATION	W	P	E	F	D	D ₁
SOP16	16.0±0.3	8.0±0.1	1.75±0.1	7.5±0.1	1.55 ^{+0.1}	1.5 ^{+0.25}

APPLICATION	P ₀	P ₁	A ₀	B ₀	K ₀	t
SOP16	4.0±0.1	2.0±0.1	6.5±0.1	10.3±0.1	2.1±0.1	0.30±0.05

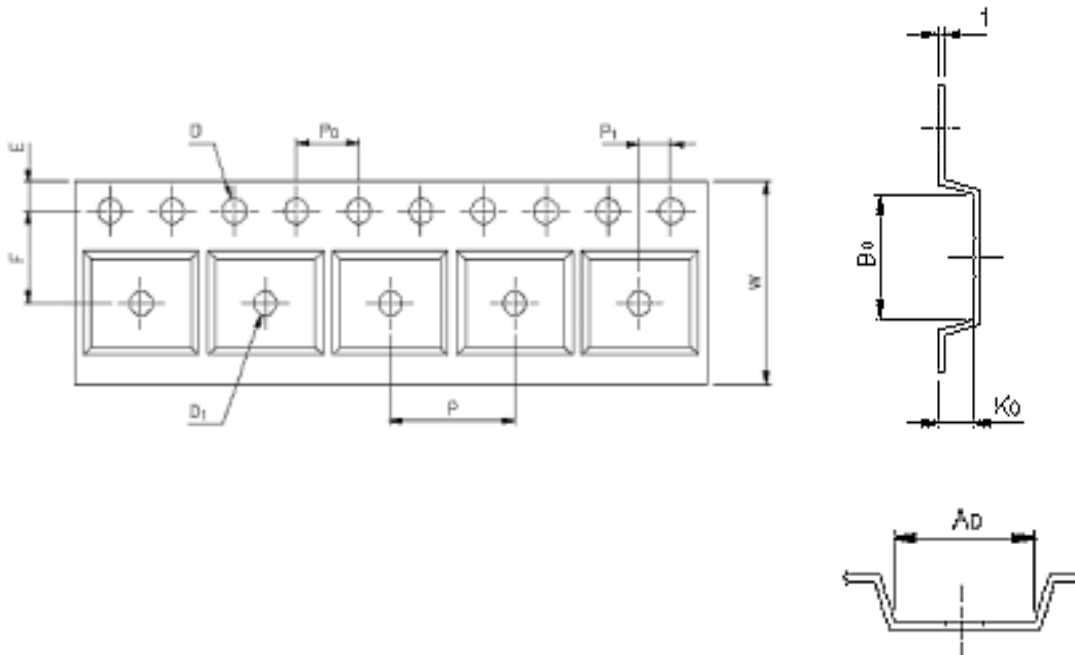

REEL DIMENSIONS

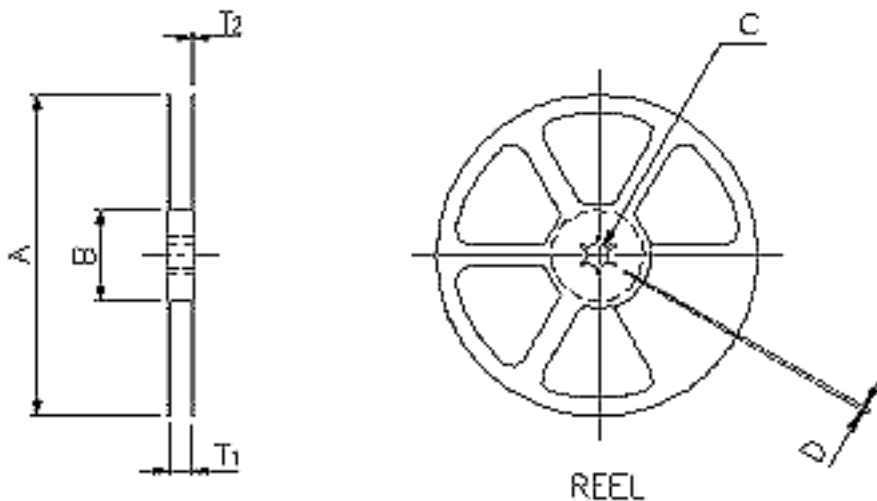

APPLICATION	MATERIAL	A	B	C	D	T1	T2
SOP16	PLASTIC REEL (BLUE)	330±3	100±2.0	13.0±0.5	2.0±0.5	16.4 ^{+0.3} _{-0.2}	2.5±0.5

CARRIER TAPE DIMENSIONS

SSOP16

APPLICATION	W	P	E	F	D	D ₁
SSOP16	12.0±0.3	8.0±0.1	1.75±0.1	5.5±0.05	1.5 ^{+0.1}	1.5 ^{+0.25}

APPLICATION	P ₀	P ₁	A ₀	B ₀	K ₀	t
SSOP16	4.0±0.1	2.0±0.05	6.5±0.1	10.3±0.1	2.1±0.1	0.30±0.05

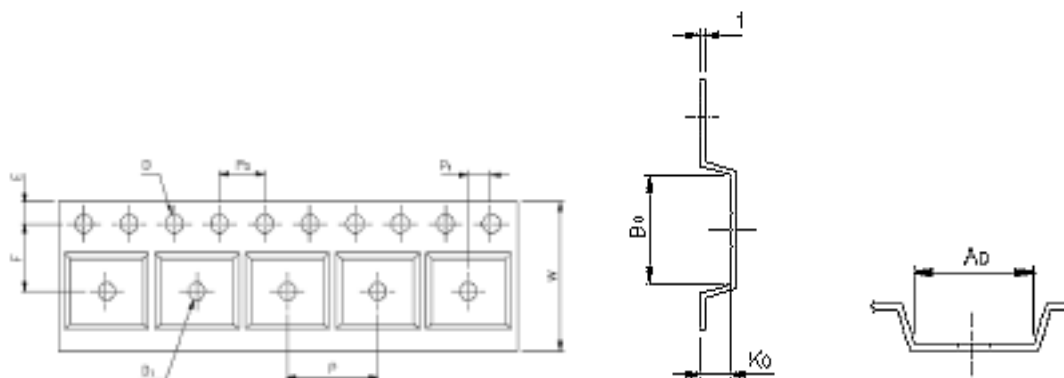

REEL DIMENSIONS

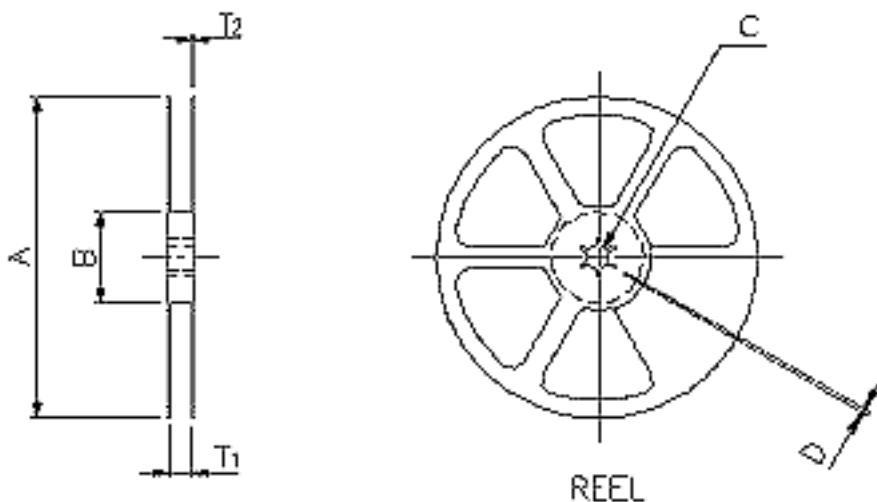

APPLICATION	MATERIAL	A	B	C	D	T1	T2
SSOP16	PLASTIC REEL (BLUE)	330	62	12.75 ^{+0.15}	2.0±0.15	12.4	16.8