

Peak 2A Bus Termination Regulator

Description

The FP6137D linear regulator is designed to provide the transient peaks up to 2A sourcing or sinking capability for DDR SDRAM bus termination application. The output voltage can track half of input power by two external voltage divider resistors.

The FP6137D provides current limiting in both sourcing/sinking mode and thermal shutdown function which protects the excessive heating due to high current and high junction temperature.

The FP6137D is available in the SOP-8 (Exposed Pad) package.

Features

- Peak 2A Source or Sink Current
- Power MOSFET Integrated
- Low Output Voltage Offset
- Current Limiting Protection
- Thermal Shutdown Protection
- Adjusted Output by External Resistors
- Shutdown for Standby or Suspend Mode
- RoHS Compliant

Applications

- DDR-I and DDR-II Bus Termination Voltage
- SSTL-2 and SSTL-3 Termination
- Active Termination Buses

Pin Assignments

SP Package (SOP-8<Exposed Pad>)

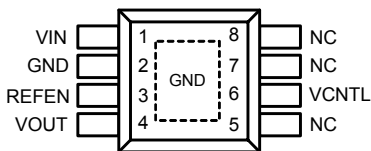
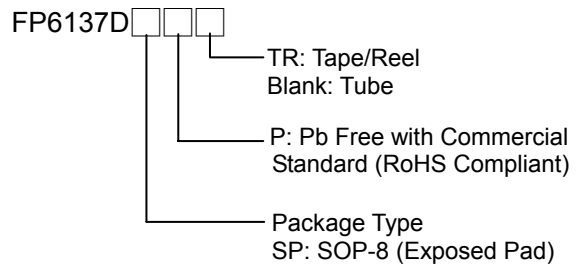

Figure 1. Pin Assignment of FP6137D (Top View)

Ordering Information



Typical Application Circuit

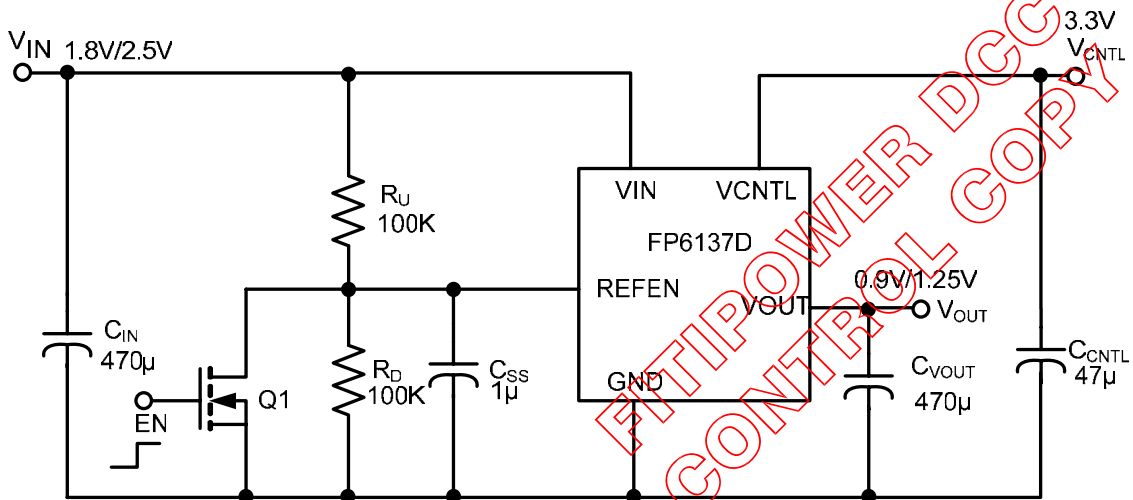

Figure 2. Typical Application Circuit of FP6137D

Functional Pin Description

Pin Name	Pin Function
VIN	Power input pin. VIN is the input power supply used to create the external reference voltage for regulating VOUT. VIN sources current to VOUT by upper NMOS.
GND	Common ground pin. The VOUT sinks current to GND by lower NMOS.
VCNTL	Power input pin. The VCNTL power supplies the internal control circuitry and gate drive voltage.
REFEN	Chip enable, and input reference voltage pin. The reference voltage is half of the VIN power by two external voltage divide resistors.
VOUT	Regulator output pin. VOUT voltage tracks the REFEN voltage and is capable of sourcing or sinking current up to peak 2A.

Block Diagram

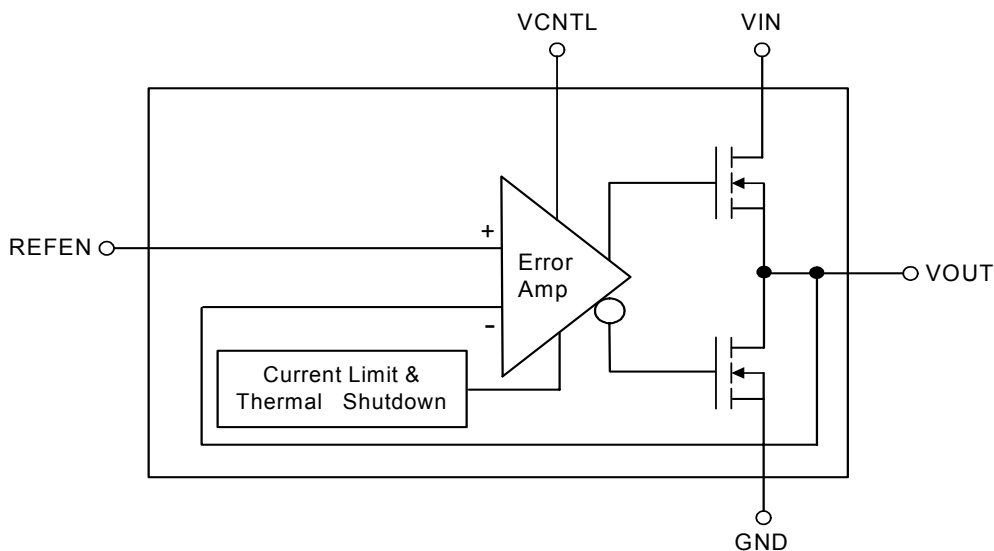

Figure 3. Block Diagram of FP6137D

Absolute Maximum Ratings

- VIN to GND ----- 6V
- VCNTL to GND ----- 6V
- Power Dissipation ----- Internal Limited
- Junction Temperature ----- 150°C
- Storage Temperature Range ----- 65°C to 150°C
- Package Thermal Resistance :
 - SOP-8 (Exposed Pad), θ_{JC} ----- 10.4°C/W
 - SOP-8 (Exposed Pad), θ_{JA} ----- 80°C/W
- Lead Temperature (Soldering, 10sec.) ----- 260°C
- ESD Susceptibility
 - HBM(Human Body Mode) ----- 2KV
 - MM(Machine Mode) ----- 200V

Note : Stresses beyond those listed under "Absolute Maximum Ratings" may cause permanent damage to the device.

Electrical Characteristics

($V_{CNTL}=3.3V$, $V_{IN}=2.5V$, $V_{REFEN}=0.5*V_{IN}$, $C_{OUT}=10\mu F$, $T_A=25^{\circ}C$, unless otherwise specified)

Parameter	Symbol	Test Conditions	Min	Typ	Max	Units
INPUT						
Operation Voltage Range	V_{IN}		1.6	1.8/2.5		V
	V_{CNTL}			3.3	5.5	
V_{CNTL} Quiescent Current	I_{CNTL}	No Load		1.5	3.0	mA
Shutdown Current	I_{SD}	$V_{REFEN}<0.2V$		5	30	μA
OUTPUT VOLTAGE						
Output Offset Voltage	V_{OS}	No Load , ($V_{REFEN}-V_{OUT}$)	-20	0	20	mV
Load Regulation (DDR1 and DDII)	$ \Delta V_{LOAD} $	I_{OUT} : 0 to 1.5A			20	mV
		I_{OUT} : 0 to -1.5A				
PROTECTION						
Current Limit	I_{LIM}		2.0			A
Thermal Shutdown	T_{SD}			170		$^{\circ}C$
Thermal Shutdown Hysteresis	ΔT_{SD}			35		$^{\circ}C$
SHUTDOWN CONTROL						
Minimum Shutdown High Level	V_{IH}		0.6			V
Minimum Shutdown Low Level	V_{IL}				0.2	V

FITIPOWER DCC
CONTROL COPY

Typical Performance Curves

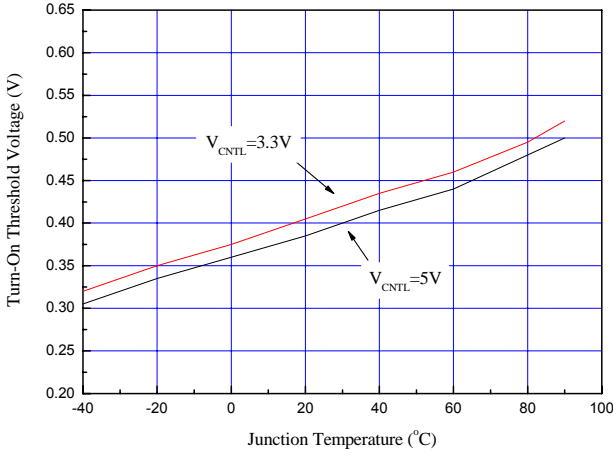

Figure 4. Turn-On Threshold Voltage vs. Junction Temperature

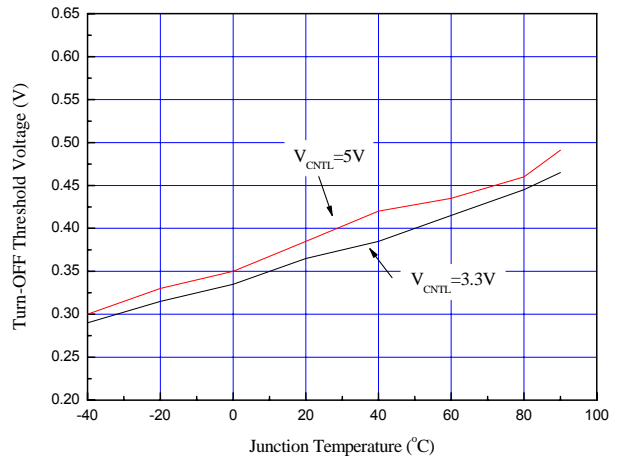

Figure 5. Turn-Off Threshold Voltage vs. Junction Temperature

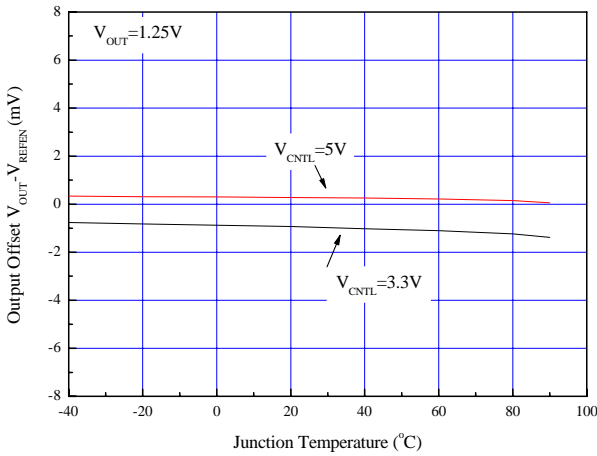

Figure 6. Output offset ($V_{OUT} - V_{REFEN}$) vs. Junction Temperature

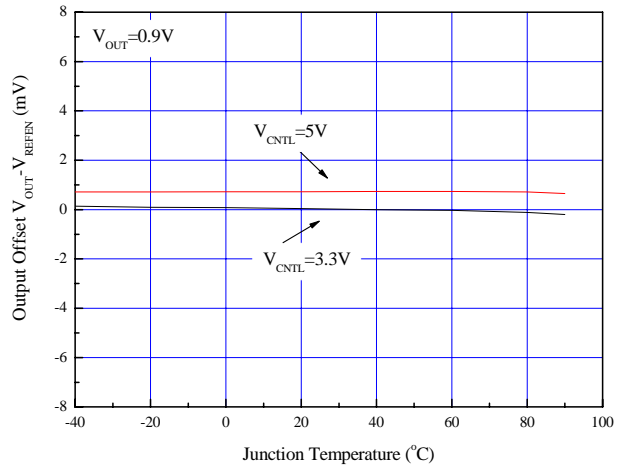

Figure 7. Output offset ($V_{OUT} - V_{REFEN}$) vs. Junction Temperature

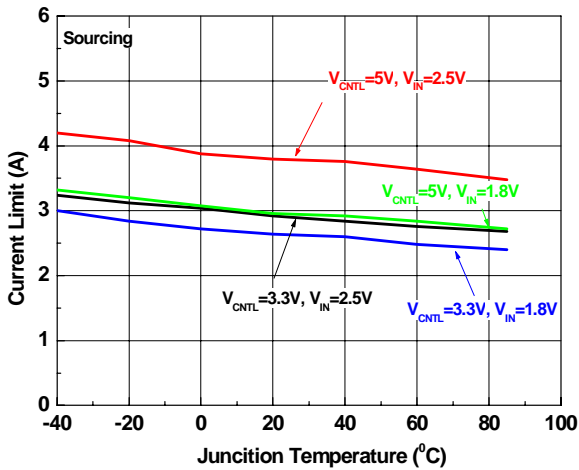

Figure 8. Current Limit vs. Junction Temperature

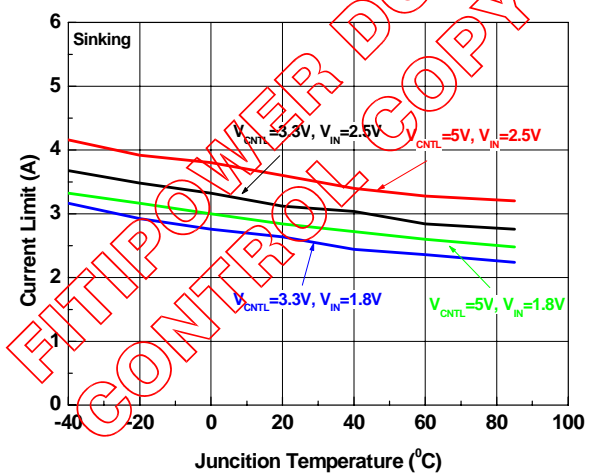

Figure 9. Current Limit vs. Junction Temperature

Typical Performance Curves (Continued)

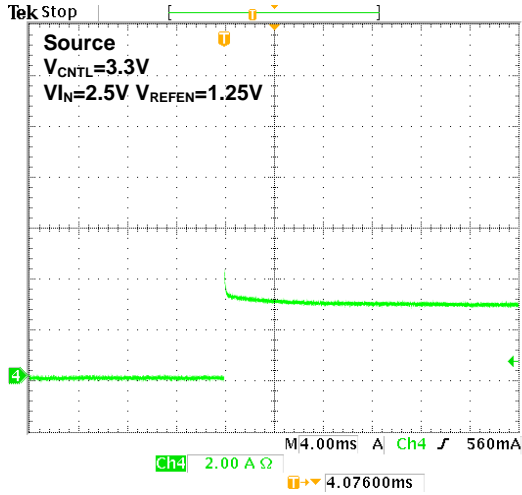

Figure 10. Output Short-Circuit Protection

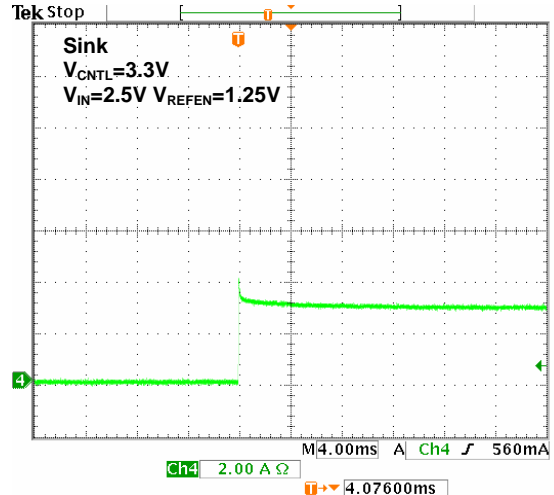

Figure 11. Output Short-Circuit Protection

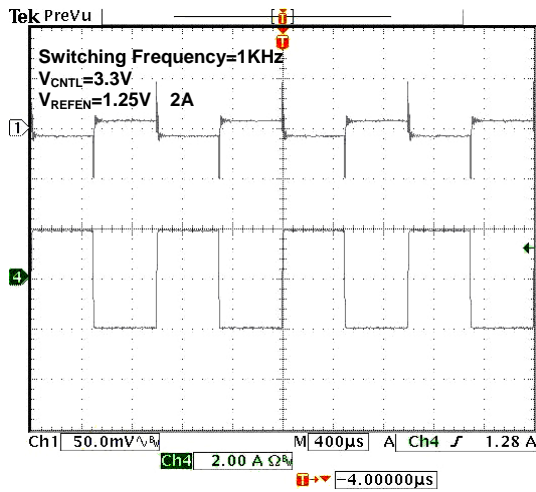

Figure 12. 1.25V_{OUT} @ 2A Transient Response

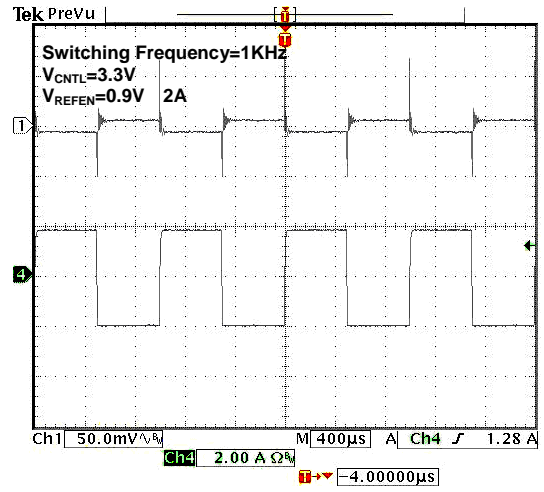
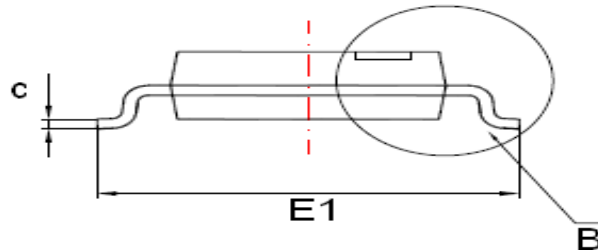
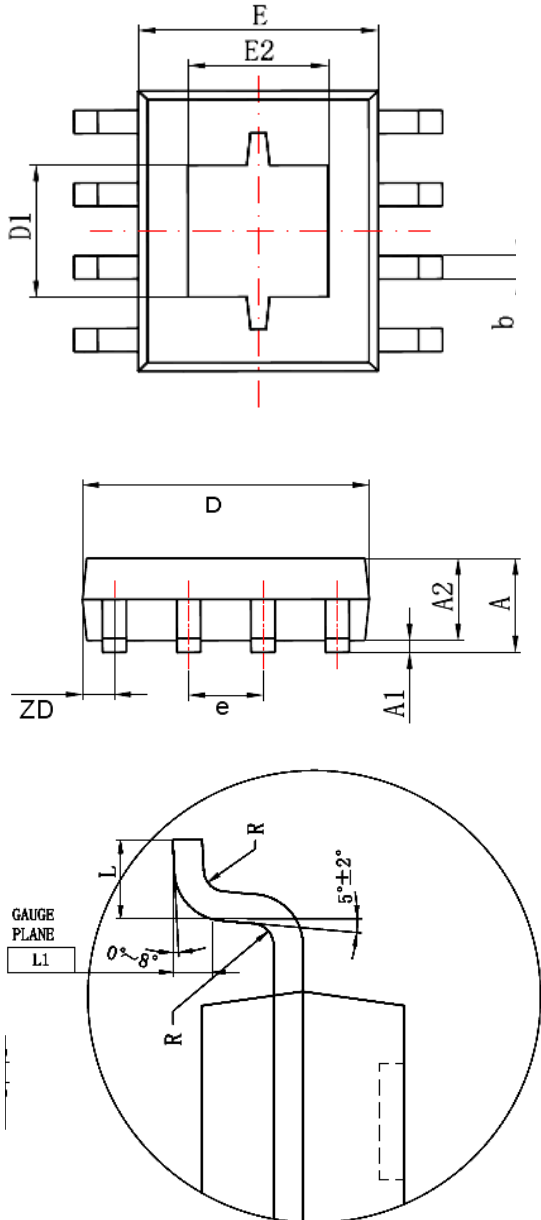

Figure 13. 0.9V_{OUT} @ 2A Transient Response

FITIPOWER DCG
CONTROL COPY

Outline Information

SOP-8 (Exposed Pad) Package (Unit: mm)



SYMBOLS	DIMENSIONS IN MILLIMETER		
	Min	Nom	Max
A			1.70
A1	0.05	---	0.15
A2	1.35	1.45	1.55
c	0.10	---	0.25
E	3.75	3.95	4.15
E1	5.70	6.00	6.30
E2	2.086	2.286	2.486
L	0.30	0.50	0.70
L1	---	0.25 BASIC	---
R	---	0.200 REF	---
b	0.31	0.41	0.51
D	4.72	4.92	5.12
D1	2.086	2.286	2.486
ZD			
e	1.27BASIC		

Note 1 : PACKAGE BODY SIZES EXCLUDE MOLDFLASH AND GATE BURRS

Note 2 : DIMENSION L IS MEASURED IN GAGE PLANE

Note 3 : TOLERANCE 0.10 mm UNLESS OTHERWISE SPECIFIED

Note 4 : CONTROLLING DIMENSION IS MILLIMETER. CONVERTED INCH DIMENSIONS ARE NOT NECESSARILY EXACT.

Note 5 : FOLLOWED FROM JEDEC MS-012

FITIPOWER DCG
CONTROL COPY

Life Support Policy

Fitipower's products are not authorized for use as critical components in life support devices or other medical systems.