

## 3A BUS TERMINATION REGULATOR

### Description

The FP6137F linear regulator is designed to provide the transient peaks up to 3A sourcing or sinking capability for DDR SDRAM bus termination application. The output voltage can track half of input power by two external voltage divider resistors.

The FP6137F provides current limiting in both sourcing/sinking mode and thermal shutdown function which protects the excessive heating due to high current and high junction temperature.

The FP6137F is available in SOP-8 (Exposed Pad) package.

### Features

- Peak 3A Source or Sink Current
- Power MOSFET Integrated
- Low Output Voltage Offset
- Built-in Soft-start
- Current Limiting Protection
- Thermal Shutdown Protection
- Adjustable Output by External Resistors
- Shutdown for Standby or Suspend Mode
- RoHS Compliant

### Applications

- DDR-I, DDR-II, DDR-III ,and DDR-IIIL Bus Termination Voltage
- SSTL-2 and SSTL-3 Termination
- Active Termination Buses

### Pin Assignments

SP Package (SOP-8 Exposed Pad)

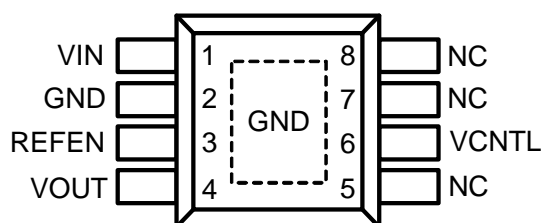
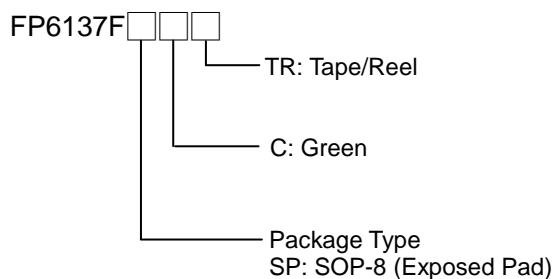

Figure 1. Pin Assignment of FP6137F (Top View)

### Ordering Information



## Typical Application Circuit

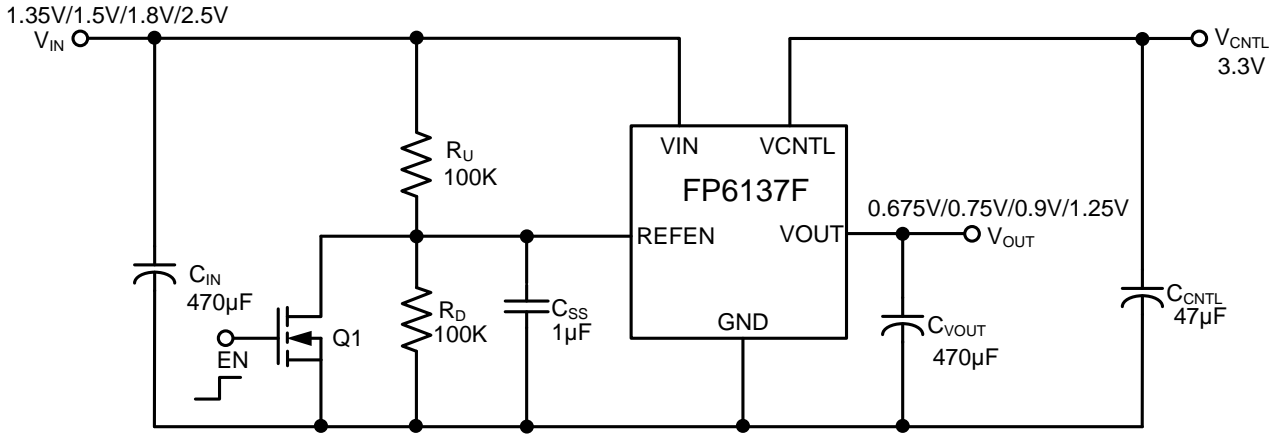
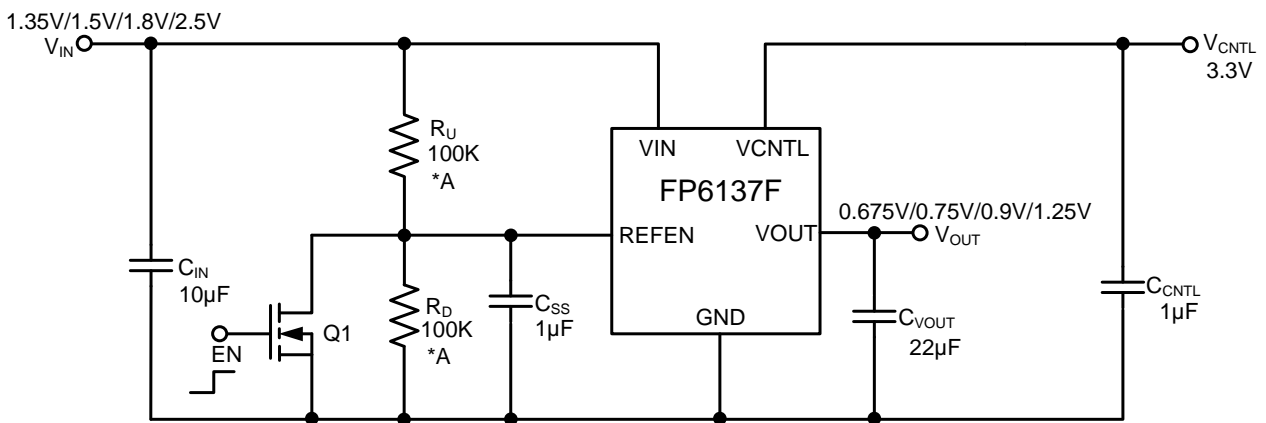

Figure 2. Typical Application Circuit of FP6137F with EC Capacitors



Note A: The recommend value of resistor is 10k~100k

Figure 3. Typical Application Circuit of FP6137F with MLCC Capacitors

## Functional Pin Description

Pin Name	Pin Function
<b>VIN</b>	Power input pin. VIN is the input power supply used to create the external reference voltage for regulating VOUT. VIN sources current to VOUT by upper NMOS.
<b>GND</b>	Common ground pin. The VOUT sinks current to GND by lower NMOS.
<b>VCNTL</b>	Power input pin. The VCNTL power supplies the internal control circuitry and gate drive voltage.
<b>REFEN</b>	Chip enable, and input reference voltage pin. The reference voltage is half of the VIN power by two external voltage divide resistors.
<b>VOUT</b>	Regulator output pin. VOUT voltage tracks the REFEN voltage and is capable of sourcing or sinking current up to peak 3A.

## Block Diagram

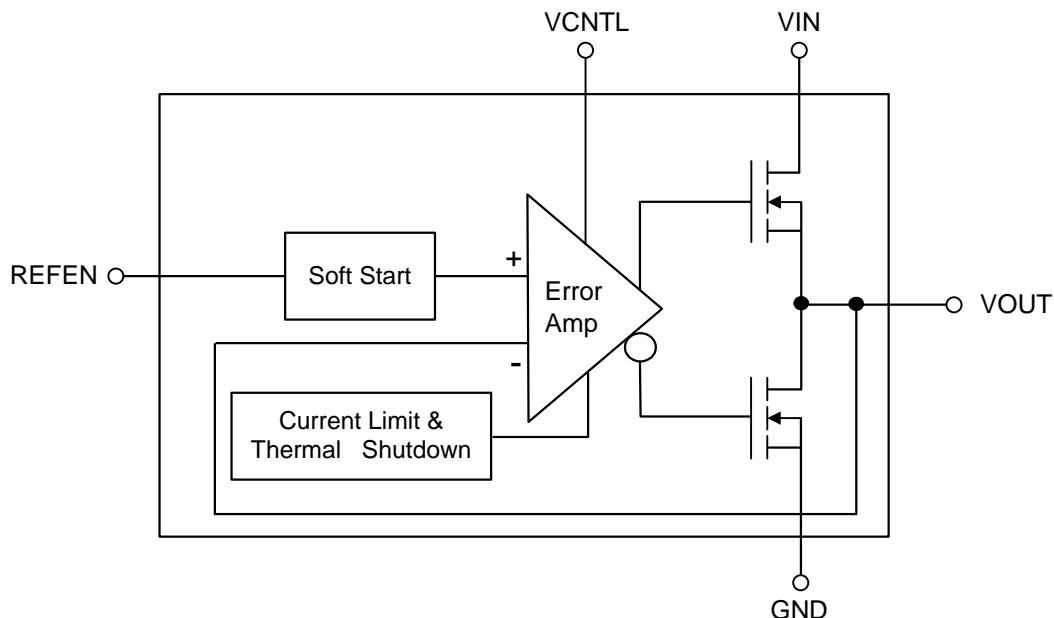

Figure 4. Block Diagram of FP6137F

## Absolute Maximum Ratings

- VIN to GND ----- 6V
- VCNTL to GND ----- 6V
- Power Dissipation @25°C (P<sub>D</sub>) SOP-8 (Exposed Pad) ----- 1.25W
- Package Thermal Resistance (θ<sub>JA</sub>) SOP-8 (Exposed Pad) ----- 80°C/W
- Junction Temperature ----- 150°C
- Storage Temperature Range ----- -65°C to +150°C
- Lead Temperature (Soldering, 10sec.) ----- 260°C

Note 1 : Stresses beyond those listed under "Absolute Maximum Ratings" may cause permanent damage to the device.

## Recommended Operating Conditions

- Input Voltage (V<sub>IN</sub>) ----- (1.35V, 1.5V, 1.8V, 2.5V) ±5%
- Input Voltage (V<sub>CNTL</sub>) ----- (3.3V to 5.5V) ±5%
- Operating Temperature Range (T<sub>OPR</sub>) ----- -40°C to +85°C

## Electrical Characteristics

( $V_{CNTL}=3.3V$ ,  $V_{IN}=1.35V/1.5V/1.8V/2.5V$ ,  $V_{REFEN}=0.5 \cdot V_{IN}$ ,  $C_{OUT}=10\mu F$ ,  $T_A=25^\circ C$ , unless otherwise specified)

Parameter	Symbol	Test Conditions	Min	Typ	Max	Units
<b>INPUT</b>						
Operation Voltage Range (DDR1 /DDII/ DDR-III/ DDR-IIIL)	$V_{CNTL}$			3.3	5.5	V
$V_{CNTL}$ Quiescent Current	$I_{CNTL}$	No Load		1.5	3.0	mA
Shutdown Current	$I_{SD}$	$V_{REFEN}<0.2V$		5	30	$\mu A$
<b>OUTPUT VOLTAGE</b>						
Output Offset Voltage	$V_{OS}$	No Load , ( $V_{REFEN}-V_{OUT}$ )	-20	0	20	mV
Load Regulation (Note2) (DDR1/DDII/DDR-III/ DDR-IIIL)	$ \Delta V_{LOAD} $	$I_{OUT} = 0$ to 2A			20	mV
		$I_{OUT} = 0$ to -2A			20	
Line Regulation		$V_{CC}=3.3V$ to 5.5V, No Load		1	20	mV
<b>PROTECTION</b>						
Soft-Start Time	$T_{SS}$			400		$\mu s$
Current Limit	$I_{LIM}$		3.0	4.0		A
Thermal Shutdown Temperature (Note3)	$T_{SD}$			170		$^\circ C$
	$\Delta T_{SD}$	Hysteresis		35		$^\circ C$
<b>SHUTDOWN CONTROL</b>						
Enable High Level	$V_{REF-H}$		0.6			V
Shutdown Low Level	$V_{REF-L}$				0.2	V

Note 2 : Load regulation is measured at a constant junction temperature by using a 20ms low duty cycle current pulse.

Note 3 : Guarantee by design.

**Typical Performance Curves**

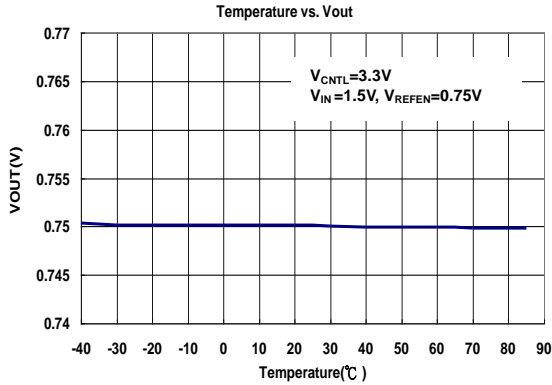

Figure 5. Temperature vs. Vout

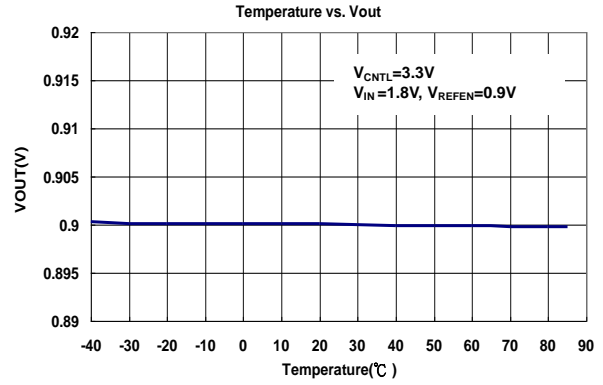

Figure 6. Temperature vs. Vout

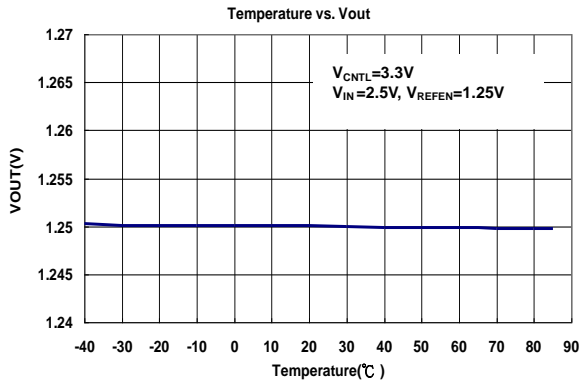

Figure 7. Temperature vs. Vout

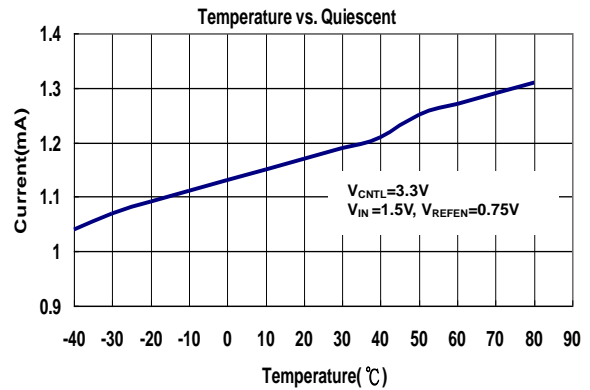

Figure 8. Temperature vs. Quiescent Current

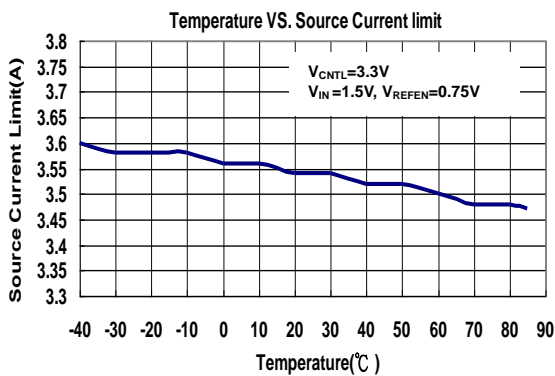

Figure 9. Temperature vs. Source Current Limit

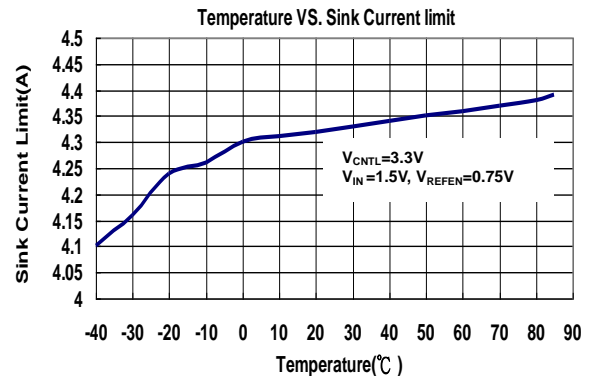

Figure 10. Temperature vs. Sink Current Limit

**Typical Performance Curves (Continued)**

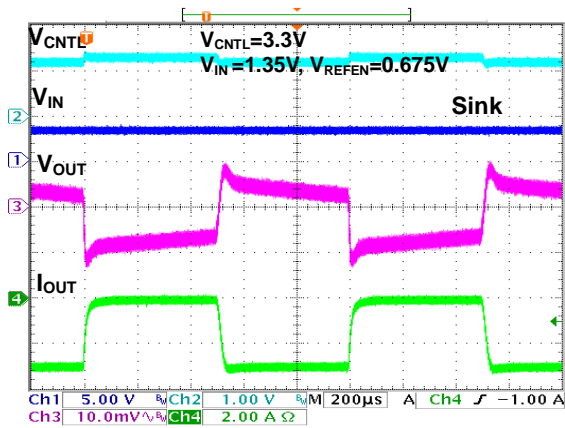

Figure11. Output Transient Response

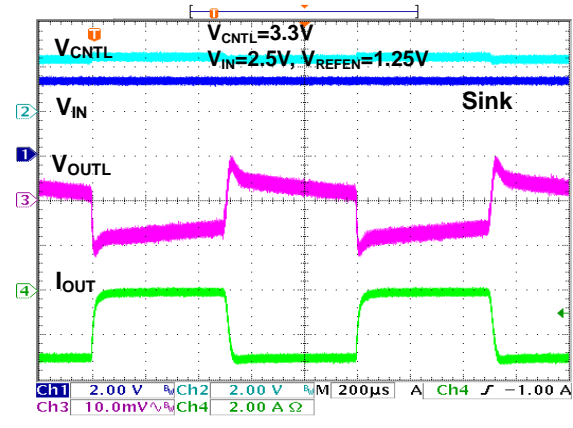

Figure12. Output Transient Response

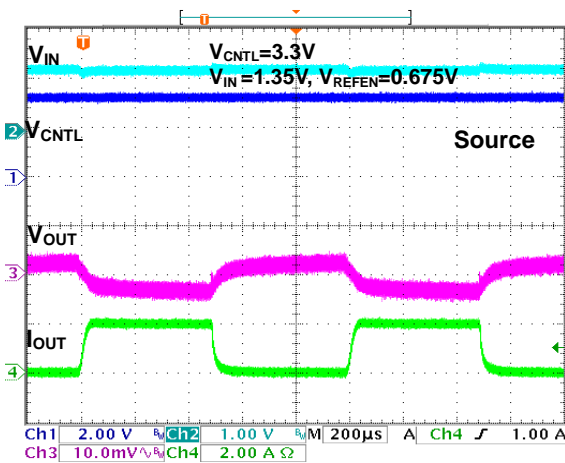

Figure13. Output Transient Response

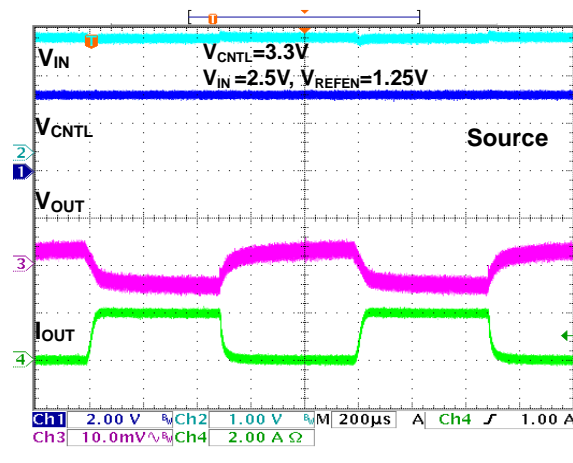

Figure14. Output Transient Response

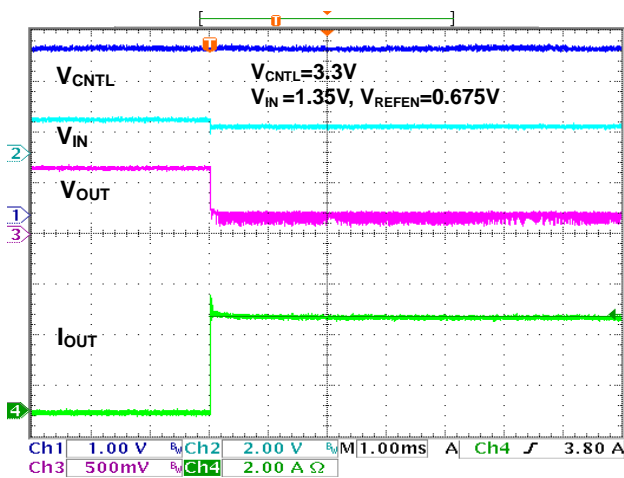

Figure15. Output Short-Circuit Protection

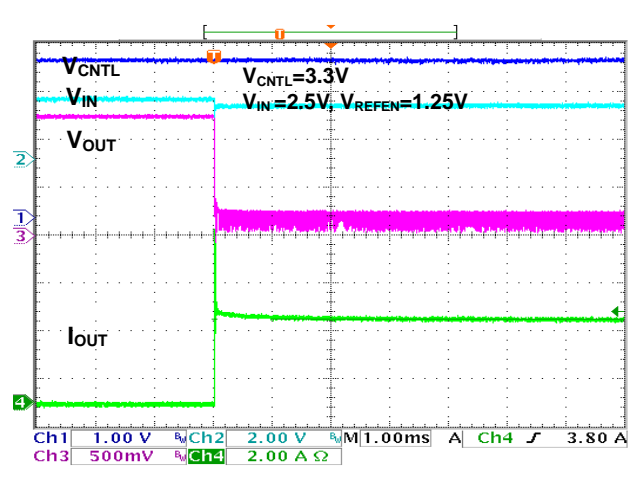
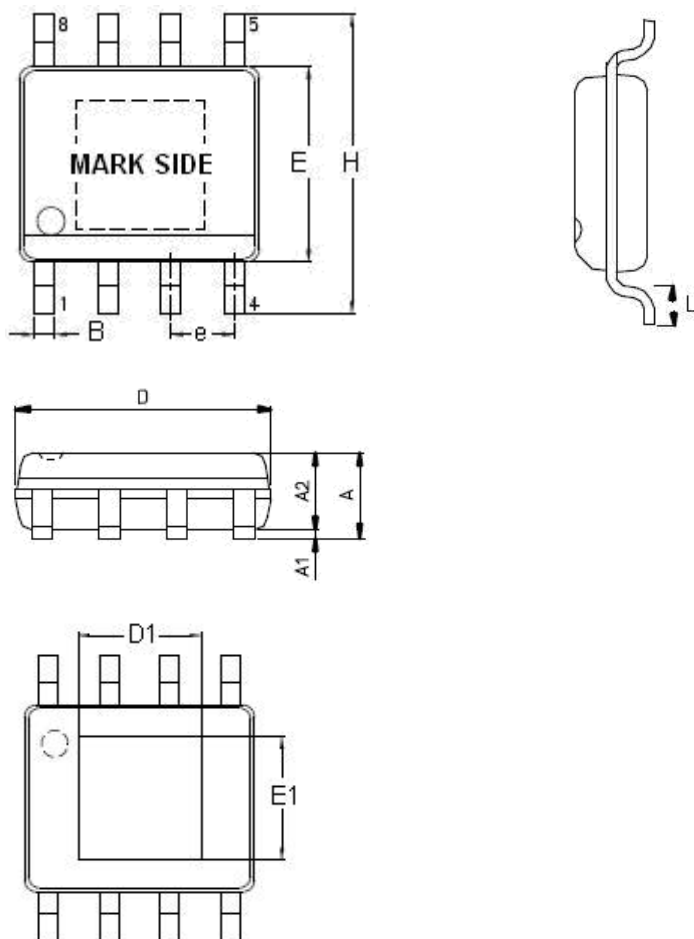

Figure16. Output Short-Circuit Protection

**Outline Information**

**SOP-8 (Exposed Pad) Package (Unit: mm)**



SYMBOLS UNIT	DIMENSION IN MILLIMETER	
	MIN	MAX
A	1.25	1.70
A1	0.00	0.15
A2	1.25	1.55
B	0.31	0.51
D	4.80	5.00
D1	3.04	3.50
E	3.80	4.00
e	1.20	1.34
H	5.80	6.20
L	0.40	1.27

Note : Followed From JEDEC MO-012-E.

**Carrier dimensions**

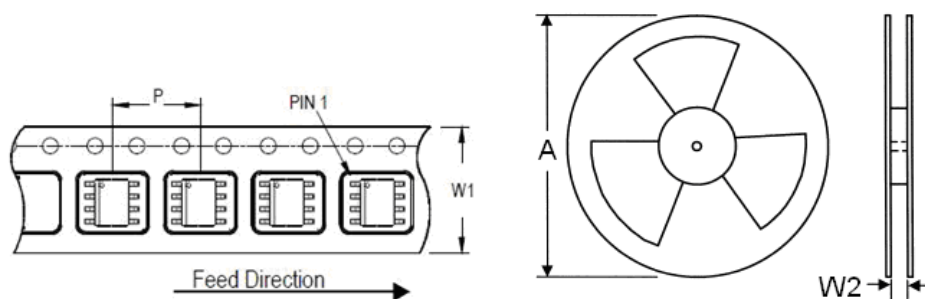

Tape Size (W1) mm	Pocket Pitch (P) mm	Reel Size (A)		Reel Width (W2) mm	Empty Cavity Length mm	Units per Reel
		in	mm			
12	8	13	330	12.4	400~1000	2,500

**Life Support Policy**

Fitipower's products are not authorized for use as critical components in life support devices or other medical systems.