

1.5MHz, 800mA Synchronous Step-Down Regulator



General Description

The FP6160 is a high efficiency current mode synchronous buck PWM DC-DC regulator. The internal generated 0.6V precision feedback reference voltage is designed for low output voltage. Low $R_{DS(ON)}$ synchronous switch dramatically reduces conduction loss. To extend battery life for portable application, 100% duty cycle is supported for low-dropout operation. Shutdown mode also helps saving the current consumption. The FP6160 is packaged in SOT23-5L, and TSOT23-5L to reduce PCB space.

Features

- Input Voltage Range: 2.5 to 5.5V
- Precision Feedback Reference Voltage: 0.6V ($\pm 2\%$)
- Output Current: 0.8A (Max.)
- Duty Cycle: 0~100%
- Internal Fixed PWM Frequency: 1.5MHz
- Low Quiescent Current: 100 μ A
- No Schottky Diode Required
- Built-in Soft Start
- Current Mode Operation
- Over Temperature Protection
- Package: SOT23-5L, TSOT23-5L

Applications

- Cellular Phones
- Wireless and DSL Modems
- Digital Still Cameras
- Portable Products
- MP3 Players

Typical Application Circuit

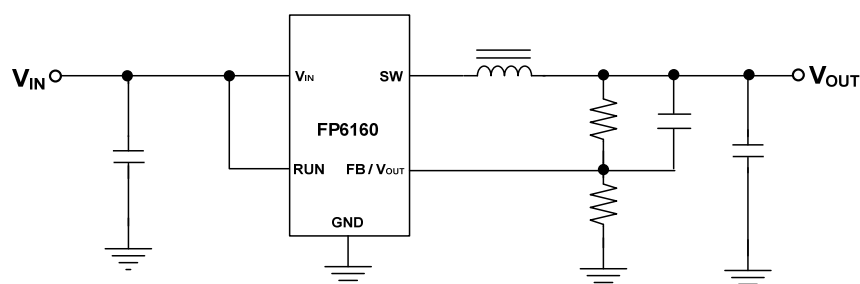

This datasheet contains new product information. Feeling Technology reserves the rights to modify the product specification without notice. No liability is assumed as a result of the use of this product. No rights under any patent accompany the sales of the product.

Function Block Diagram

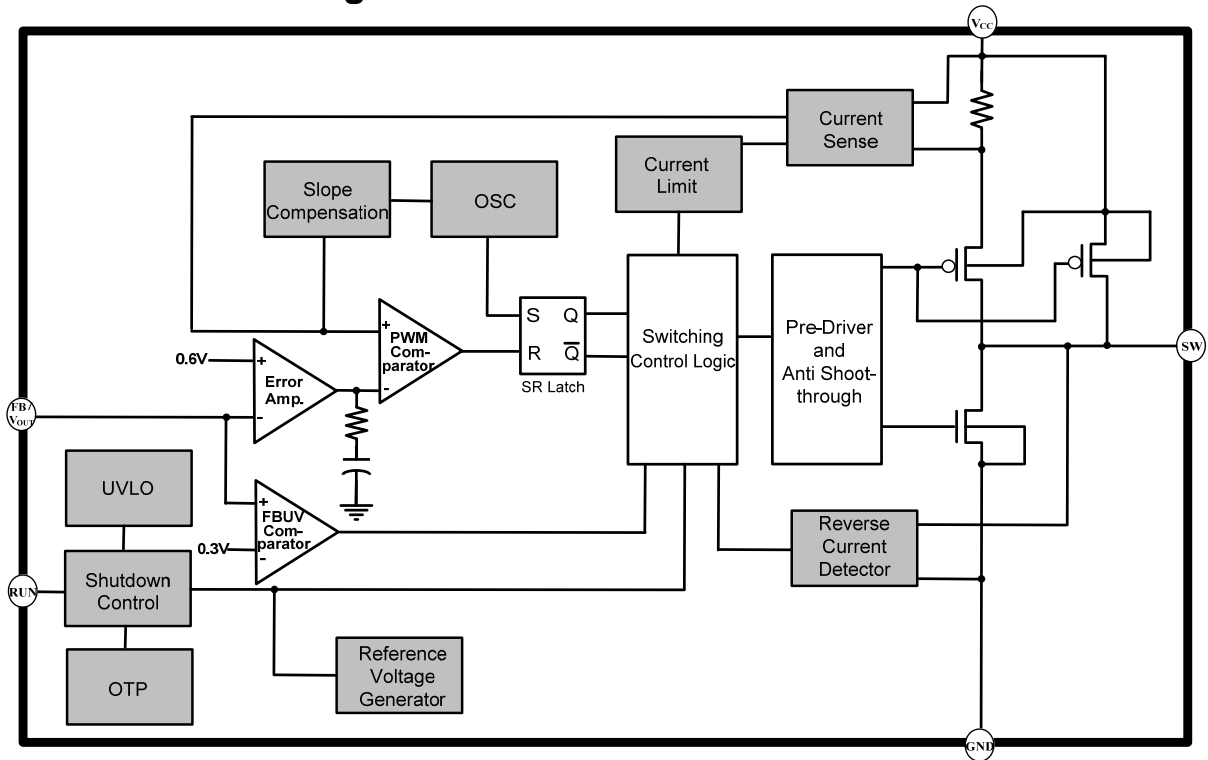

Pin Descriptions

SOT23-5L / TSOT23-5L

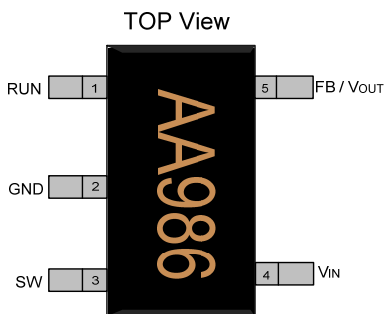

Name	No.	I / O	Description
RUN	1	I	Enable
GND	2	P	Ground
SW	3	O	Switch
V _{IN}	4	P	Power Supply
FB / V _{OUT}	5	I	Feedback

This datasheet contains new product information. Feeling Technology reserves the rights to modify the product specification without notice. No liability is assumed as a result of the use of this product. No rights under any patent accompany the sales of the product.

Website: <http://www.feeling-tech.com.tw>

Rev. 0.66

Marking Information

SOT23-5L / TSOT23-5L

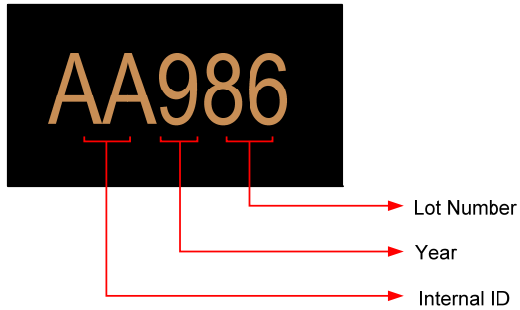

Lot Number: Wafer lot number's last two digits

For Example: 132386TB → 86

Year: Production year's last digit

Internal ID: Internal Identification Code

Ordering Information

Part Number	Code	Operating Temperature	Package	MOQ	Description
FP6160KR-LF-ADJ	AA	-40°C ~ +85°C	SOT23-5L	3000EA	Tape & Reel
FP6160iR-LF-ADJ	AA	-40°C ~ +85°C	TSOT23-5L	3000EA	Tape & Reel

Absolute Maximum Ratings

Parameter	Symbol	Conditions	Min.	Typ.	Max.	Unit
Input Supply Voltage	V_{IN}		-0.3		6	V
RUN, V_{FB} , SW Voltage			-0.3		V_{IN}	V
P-Channel Switch Source Current (DC)					0.8	A
N-Channel Switch Source Current (DC)					0.8	A
Peak SW Switch Sink and Source Current (AC)					1.5	A
Thermal Resistance (Junction to Ambient)	θ_{JA}	SOT23-5L			+250	°C / W
		TSOT23-5L			+250	°C / W
Thermal Resistance (Junction to Case)	θ_{JC}	SOT23-5L			+90	°C / W
		TSOT23-5L			+90	°C / W
Junction Temperature					+150	°C
Storage Temperature			-65		+150	°C
Allowable Power Dissipation	P_D	SOT23-5L			250	mW
		TSOT23-5L			250	mW
Lead Temperature (soldering, 10 sec)					+260	°C

IR Re-flow Soldering Curve

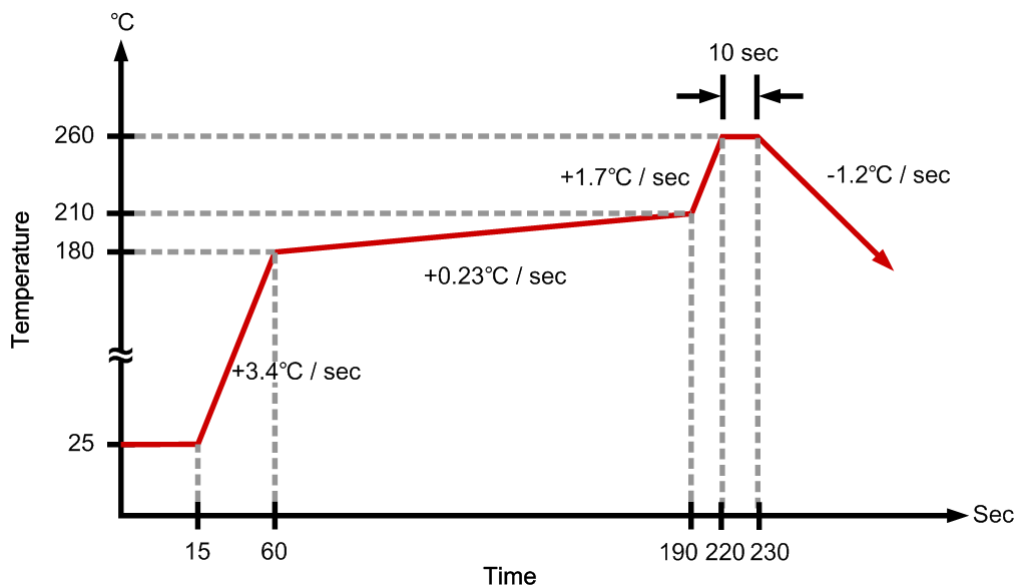

This datasheet contains new product information. Feeling Technology reserves the rights to modify the product specification without notice. No liability is assumed as a result of the use of this product. No rights under any patent accompany the sales of the product.

Recommended Operating Conditions

Parameter	Symbol	Conditions	Min.	Typ.	Max.	Unit
Supply Voltage	V_{IN}		2.5		5.5	V
Operating Temperature			-40		+85	°C

DC Electrical Characteristics ($V_{IN}=3.6V$, $T_A=25^\circ C$, unless otherwise noted)

Parameter	Symbol	Conditions	Min.	Typ.	Max.	Unit
Regulated Feedback Voltage	V_{FB}	$T_A=25^\circ C$	0.588	0.6	0.612	V
		$-40^\circ C \sim +85^\circ C$	0.582	0.6	0.618	V
Line Regulation with V_{REF}	ΔV_{FB}	$V_{IN}=2.5V$ to $5.5V$		0.04	0.4	% / V
Output Voltage Line Regulation	ΔV_{OUT}	$V_{IN}=2.5$ to $5.5V$		0.04	0.4	% / V
$R_{DS(ON)}$ of P-Channel FET	$R_{DS(ON)P}$	$I_{SW}=100mA$		0.3	0.5	Ω
$R_{DS(ON)}$ of N-Channel FET	$R_{DS(ON)N}$	$I_{SW}=-100mA$		0.25	0.45	Ω
SW Leakage	I_{LSW}	$V_{RUN}=0V$, $V_{IN}=5V$		± 0.01	± 1	μA
Peak Inductor Current	I_{PK}	$V_{FB}=0.5V$	1	1.25	1.5	A
Quiescent Current	I_{CC}	Shutdown, $V_{RUN}=0V$		0.1	1	μA
		Active, $V_{FB}=0.5V$, $V_{RUN}=V_{IN}$		100		μA
RUN Threshold	V_{RUN}		0.3	1	1.5	V
RUN Leakage Current	I_{RUN}			± 0.01	± 1	μA
Oscillator Frequency	F_{OSC}	$V_{FB}=0.6V$	1.2	1.5	1.8	MHz

This datasheet contains new product information. Feeling Technology reserves the rights to modify the product specification without notice. No liability is assumed as a result of the use of this product. No rights under any patent accompany the sales of the product.

Typical Operating Characteristics ($T_A = 25^\circ\text{C}$, $V_{IN} = 3.6\text{V}$, unless otherwise noted)

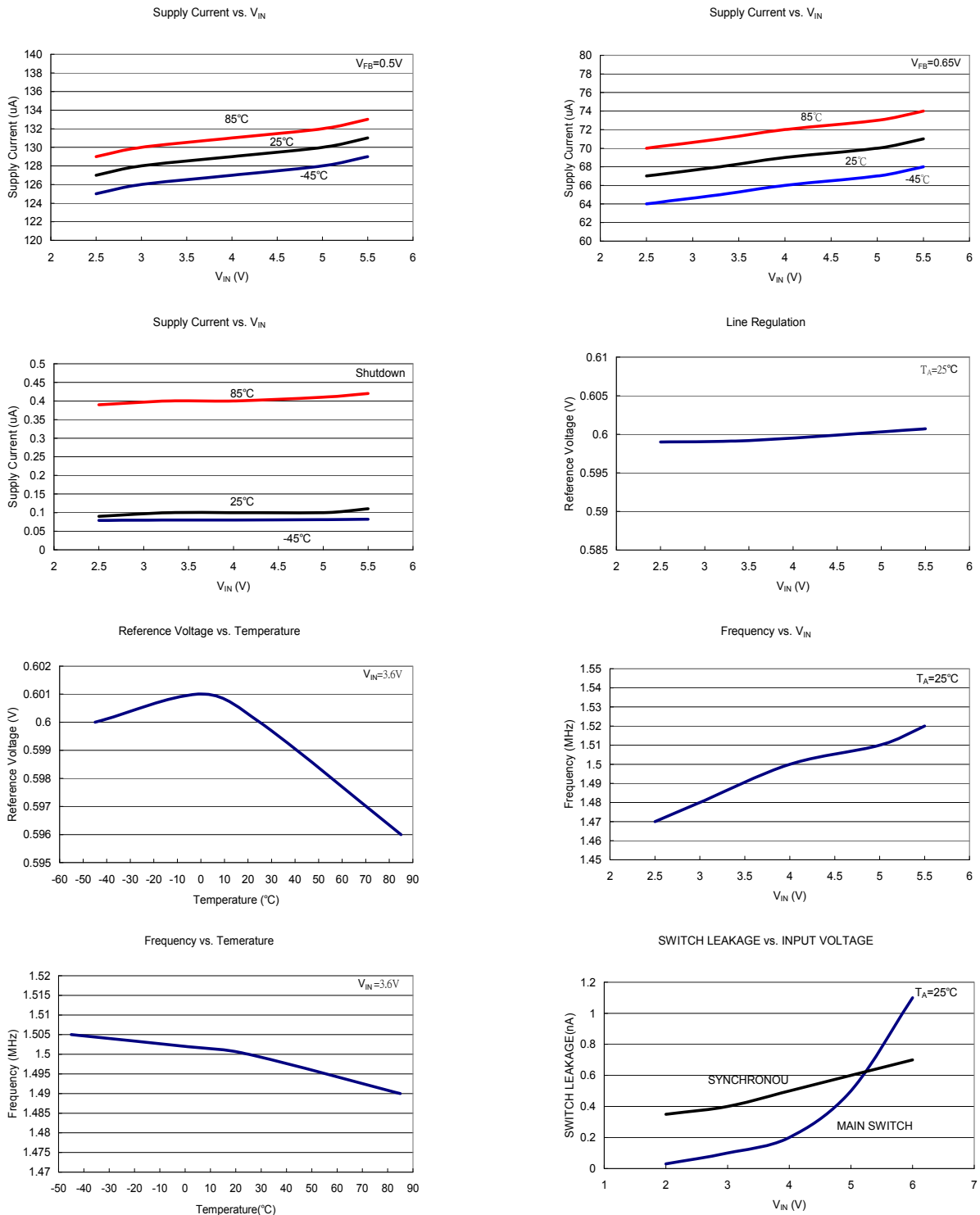

This datasheet contains new product information. Feeling Technology reserves the rights to modify the product specification without notice. No liability is assumed as a result of the use of this product. No rights under any patent accompany the sales of the product.

Function Description

Control Loop

The FP6160 is a high efficiency current mode synchronous buck regulator. Both the main (P-channel MOSFET) and synchronous (N-channel MOSFET) switches are built internally. With current mode operation, the PWM duty is controlled both by the error amplifier output and the peak inductor current. At the beginning of each cycle, the oscillator turn on the P-MOSFET switch to source current from V_{IN} to SW output. Then, the chip starts to compare the inductor current with the error amplifier output. Once the inductor current is larger than the error amplifier output, the P-MOSFET switch is turned off. When the load current increases, the feedback voltage FB will slightly drop. This causes the error amplifier to output a higher current level until the prior mentioned peak inductor current reach the same level. The output voltage then can be sustained at the same.

When the top P-MOSFET switch is off, the bottom synchronous N-MOSFET switch is turned on. Once the inductor current reverses, both top and bottom MOSFET will be turn off to leave the SW pin into high impedance state.

The FP6160's current mode control loop also contains slope compensation to suppress sub-harmonic oscillations at high duty cycles. This slope compensation is achieved by adding a compensation ramp to the inductor current signal.

LDO Mode

The FP6160's maximum duty cycle can reach 100%. That means the driver main switch is turn on through out whole clock cycle. Once the duty reaches 100%, the feedback path no longer controls the output voltage. The output voltage will be the input voltage minus the main switch voltage drop.

Over Current Protection

FP6160 limits the peak main switch current cycle by cycle. When over current happens, chip will turn off the main switch and turn the synchronous switch on until next cycle.

Short Circuit Protection

When the FB pin drops below 300mV, the chip will tri-state the output pin SW automatically. After 300us rest to avoid over heating, chip will re-initiate PWM operation with soft start.

Thermal Protection

FP6160 will shutdown automatically when the internal junction temperature reaches 150°C to protect both the part and the system.

Application Information

Input Capacitor Selection

The input capacitor must be connected to the V_{IN} pin and GND pin of the FP6160 to maintain steady input voltage and filter out the pulsing input current. The voltage rating of input capacitor must be greater than maximum input voltage plus ripple voltage.

In switch mode, the input current is discontinuous in a buck converter. The source current of the high-side MOSFET is a square wave. To prevent large voltage transients, a low ESR input capacitor sized for the maximum RMS current must be used. The RMS value of input capacitor current can be calculated by:

$$I_{RMS} = I_{O(MAX)} \sqrt{\frac{V_O}{V_{IN}} \left(1 - \frac{V_O}{V_{IN}}\right)}$$

It can be seen that when V_O is half of V_{IN} , C_{IN} is under the worst current stress. The worst current stress on C_{IN} is $I_{O(MAX)} / 2$.

Inductor Selection

The value of the inductor is selected based on the desired ripple current. Large inductance gives low inductor ripple current and small inductance result in high ripple current. However, the larger value inductor has a larger physical size, higher series resistance, and / or lower saturation current. In experience, the value is to allow the peak-to-peak ripple current in the inductor to be 10%~20% maximum load current. The inductance value can be calculated by:

$$L = \frac{(V_{IN} - V_O) V_O}{f \times \Delta I_L V_{IN}} = \frac{(V_{IN} - V_O) V_O}{f \times [2 \times (10\% \sim 20\%) I_O] V_{IN}}$$

The inductor ripple current can be calculated by:

$$\Delta I_L = \frac{V_O}{f \times L} \times \left(1 - \frac{V_O}{V_{IN}}\right)$$

Choose an inductor that does not saturate under the worst-case load conditions, which is the load current plus half the peak-to-peak inductor ripple current, even at the highest operating temperature. The peak inductor current is:

$$I_{L_PEAK} = I_O + \frac{\Delta I_L}{2}$$

The inductors in different shape and style are available from manufacturers. Shielded inductors are small and radiate less EMI issue. But they cost more than unshielded inductors. The choice depends on EMI requirement, price and size.

Inductor Value (μH)	Dimensions (mm)	Component Supplier	Model
2.2	4.2×3.7×1.2	FENG-JUI	TP4212-2R2M
2.2	4.4×5.8×1.2	Sumida	CMD4D11 2R2
3.3	4.2×3.7×1.2	FENG-JUI	TP4212-3R3M
4.7	4.2×3.7×1.2	FENG-JUI	TP4212-4R7M
4.7	4.4×5.8×1.2	Sumida	CMD4D11 4R7
4.7	4.9×4.9×1.0	Sumida	CLSD09 4R7

Output Capacitor Selection

The output capacitor is required to maintain the DC output voltage. Low ESR capacitors are preferred to keep the output voltage ripple low. In a buck converter circuit, output ripple voltage is determined by inductor value, switching frequency, output capacitor value and ESR. The output ripple is determined by:

$$\Delta V_O = \Delta I_L \times \left(\text{ESR}_{\text{COUT}} + \frac{1}{8 \times f \times C_{\text{OUT}}} \right)$$

Where f = operating frequency, C_{OUT} = output capacitance and ΔI_L = ripple current in the inductor. For a fixed output voltage, the output ripple is highest at maximum input voltage since ΔI_L increases with input voltage.

Capacitor Value (μF)	Case Size	Component Supplier	Model
4.7	0603	TDK	C1608JB0J475M
10	0805	Taiyo Yuden	JMK212BJ106MG
10	0805	TDK	C12012X5ROJ106K
22	0805 1206	TDK	C2012JB0J226M

Using Ceramic Input and Output Capacitors

Care must be taken when ceramic capacitors are used at the input and the output. When a ceramic capacitor is used at the input and the power is supplied by a wall adapter through long wires, a load step at the output can induce ringing at the input, V_{IN}. At best, this ringing can couple to the output and be mistaken as loop instability. At worst, a sudden inrush of current through the long wires can potentially cause a voltage spike at V_{IN}, large enough to damage the part. When choosing the input and output ceramic capacitors, choose the X5R or X7R dielectric formulations. These dielectrics have the best temperature and voltage characteristics of all the ceramics for a given value and size.

This datasheet contains new product information. Feeling Technology reserves the rights to modify the product specification without notice. No liability is assumed as a result of the use of this product. No rights under any patent accompany the sales of the product.

Output Voltage Programming

In the adjustable version, the output voltage is set using a resistive voltage divider from the output voltage to FB. The output voltage is:

$$V_O = 0.6V \left(1 + \frac{R_1}{R_2} \right)$$

The recommended resistor value is summarized below:

V_{OUT} (V)	R_1 (Ω)	R_2 (Ω)
0.6	200k	Not Used
1.2	200k	200k
1.5	300k	200k
1.8	200k	100k
2.5	270k	85k
3.3	306k	68k

PC Board Layout Checklist

1. The power traces, consisting of the GND trace, the SW trace and the V_{IN} trace should be kept short, direct and wide.
2. Place C_{IN} near V_{IN} Pin as closely as possible. To maintain input voltage steady and filter out the pulsing input current.
3. The resistive divider R_1 and R_2 must be connected to FB pin directly as closely as possible.
4. FB is a sensitive node. Please keep it away from switching node, SW. A good approach is to route the feedback trace on another layer and to have a ground plane between the top layer and the layer on which the feedback trace is routed. This reduces EMI radiation on to the DC-DC converter's own voltage feedback trace.
5. Keep the GND plates of C_{IN} and C_{OUT} as close as possible. Then connect this to the ground-plane (if one is used) with several vias. This reduces ground plane noise by preventing the switching currents from circulating through the ground plane. It also reduces ground bounce at the FP6160 by giving it a low impedance ground connection.

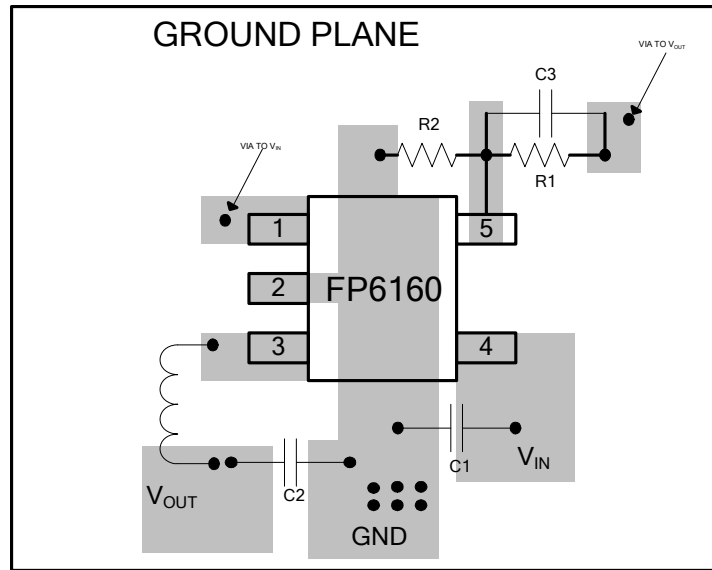

Suggested Layout

Typical Application

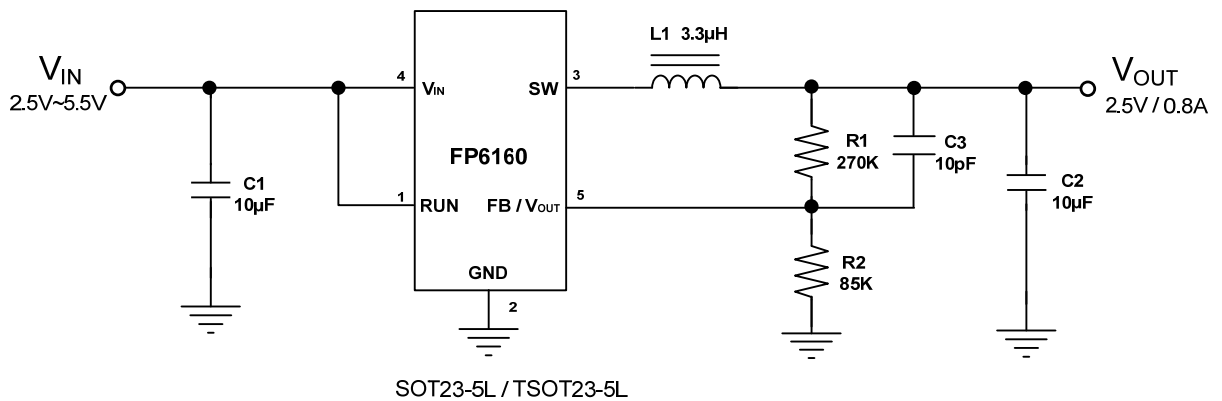

This datasheet contains new product information. Feeling Technology reserves the rights to modify the product specification without notice. No liability is assumed as a result of the use of this product. No rights under any patent accompany the sales of the product.

I_{LOAD} : 80mA~800mA

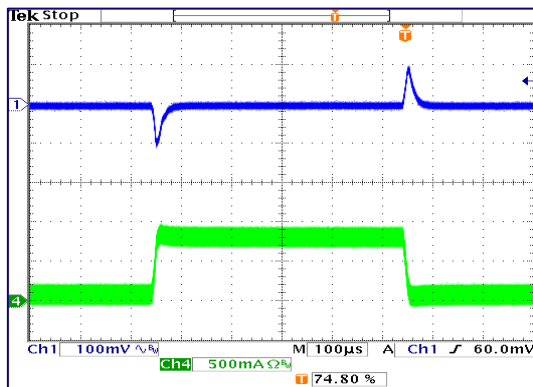

Ch1: V_{OUT} Ch2: I_{SW}

I_{LOAD} : 200mA~800mA

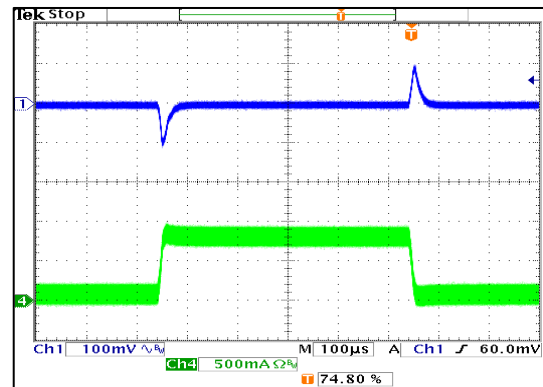

Ch1: V_{OUT} Ch2: I_{SW}

EN on waveform (V_{OUT} : 2.5V)

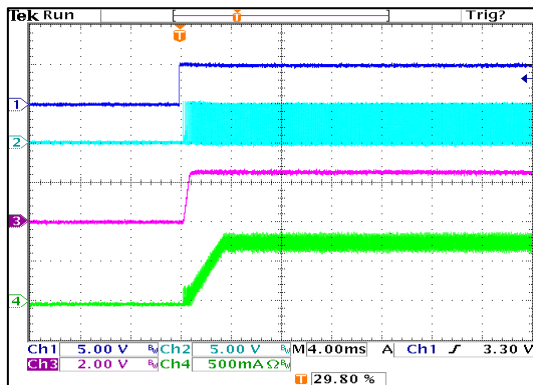

Ch1: EN Ch2: SW Ch3: V_{OUT} Ch4: I_{SW}

Efficiency (V_{OUT} : 2.5V)

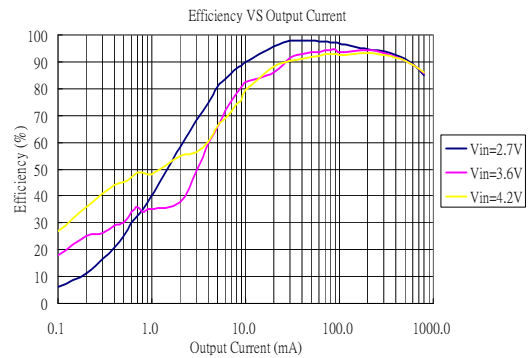

Efficiency (V_{IN} : 5.3V)

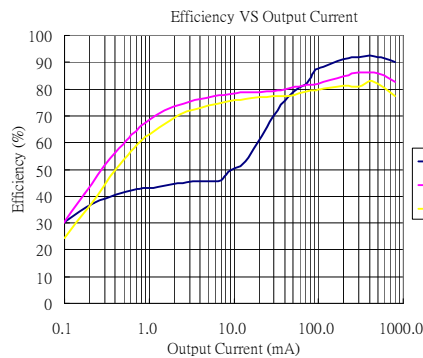

This datasheet contains new product information. Feeling Technology reserves the rights to modify the product specification without notice. No liability is assumed as a result of the use of this product. No rights under any patent accompany the sales of the product.

Package Outline

SOT23-5L

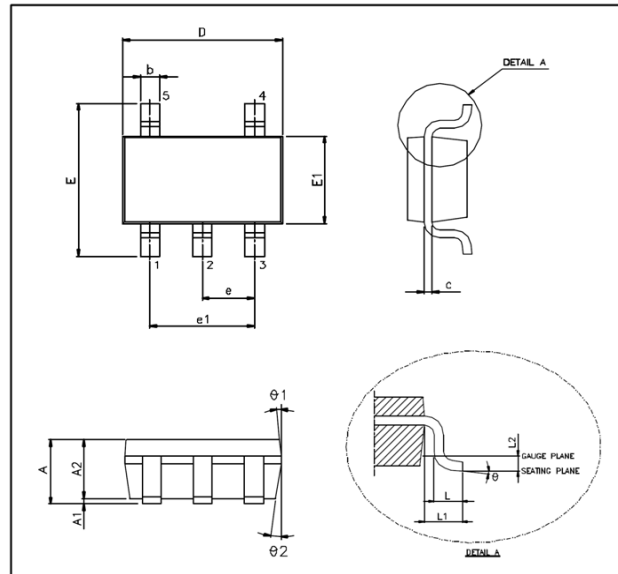

UNIT: mm

Symbols	Min. (mm)	Max.(mm)
A	1.050	1.350
A1	0.050	0.150
A2	1.000	1.200
b	0.250	0.500
c	0.080	0.200
D	2.700	3.000
E	2.600	3.000
E1	1.500	1.700
e	0.950 BSC	
e1	1.900 BSC	
L	0.300	0.550
L1	0.600 REF	
L2	0.250 BSC	
θ°	0°	10°
θ1°	3°	7°
θ2°	6°	10°

Note:

1. Package dimensions are in compliance with JEDEC outline: MO-178 AA.
2. Dimension "D" does not include molding flash, protrusions or gate burrs.
3. Dimension "E1" does not include inter-lead flash or protrusions.

This datasheet contains new product information. Feeling Technology reserves the rights to modify the product specification without notice. No liability is assumed as a result of the use of this product. No rights under any patent accompany the sales of the product.

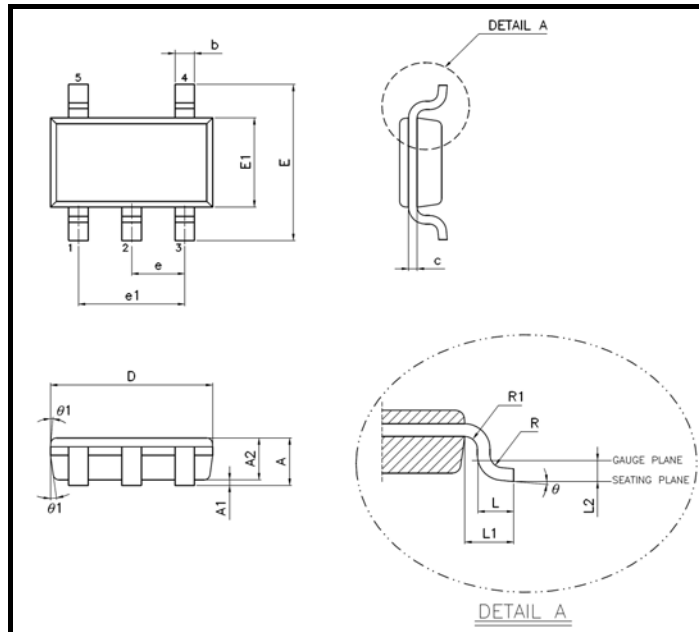
TSOT23-5L

Unit: mm

Symbols	Min. (mm)	Max. (mm)
A	0.750	0.800
A1	0.000	0.050
A2	0.700	0.775
b	0.350	0.500
c	0.100	0.200
D	2.800	3.000
E	2.600	3.000
E1	1.500	1.700
e	0.950 BSC	
e1	1.900 BSC	
L	0.370	0.600
L1	0.600 REF	
L2	0.250 BSC	
R	0.100	
R1	0.100	0.250
θ°	0°	8°
θ_1	4°	12°

Note:

1. Dimension “D” does not include molding flash, protrusions or gate burrs.
2. Dimension “E1” does not include inter-lead flash or protrusions.

This datasheet contains new product information. Feeling Technology reserves the rights to modify the product specification without notice. No liability is assumed as a result of the use of this product. No rights under any patent accompany the sales of the product.