

## Dual 1.5MHz, 1A Synchronous Step-Down Regulator



### General Description

The FP6166 is a high efficiency current mode dual synchronous buck PWM DC-DC regulator. The internal generated 0.6V precision feedback reference voltage is designed for low output voltage. Low  $R_{DS(ON)}$  synchronous switch dramatically reduces conduction loss. To extend battery life for portable application, 100% duty cycle is supported for low-dropout operation. Shutdown mode also helps saving the current consumption. The FP6166 is packaged in MSOP-10L (EP) and DFN-10L (EP) to reduce PCB space.

### Features

- Input Voltage Range: 2.5 to 5.5V
- Adjustable Output Voltage From 0.6V to  $V_{IN}$
- Precision Feedback Reference Voltage: 0.6V ( $\pm 2\%$ )
- Output Current: 1A (Max.) each channel
- Duty Cycle: 0~100%
- Internal Fixed PWM Frequency: 1.5MHz
- Low Quiescent Current: 190 $\mu$ A
- No Schottky Diode Required
- Built-in Soft Start
- Current Mode Operation
- Over temperature Protection
- Package: MSOP-10L (EP), DFN-10L (EP)

### Applications

- Cellular Telephone
- Wireless and DSL Modems
- Digital Still Cameras
- Portable Products
- MP3 Players

---

This datasheet contains new product information. Feeling Technology reserves the rights to modify the product specification without notice. No liability is assumed as a result of the use of this product. No rights under any patent accompany the sales of the product.

### Typical Application Circuit

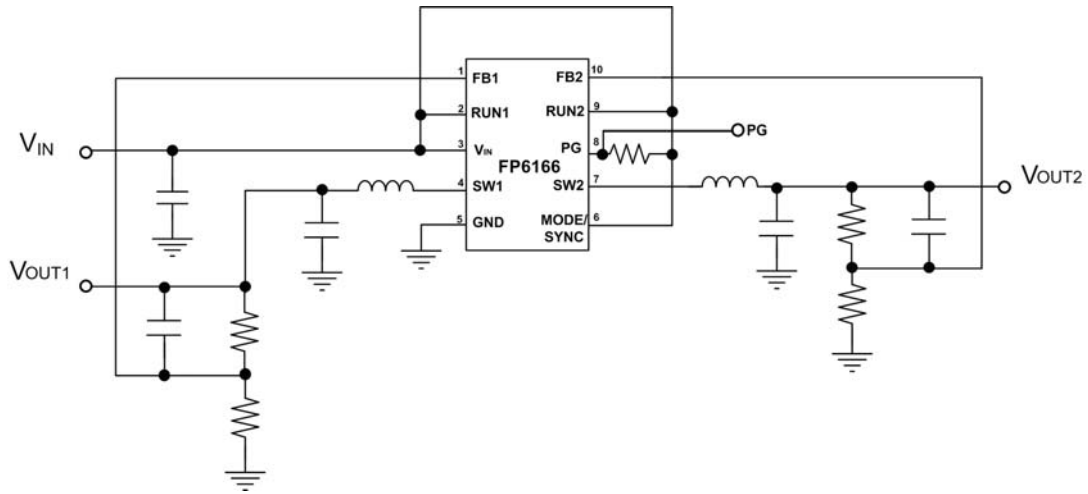

### Function Block Diagram

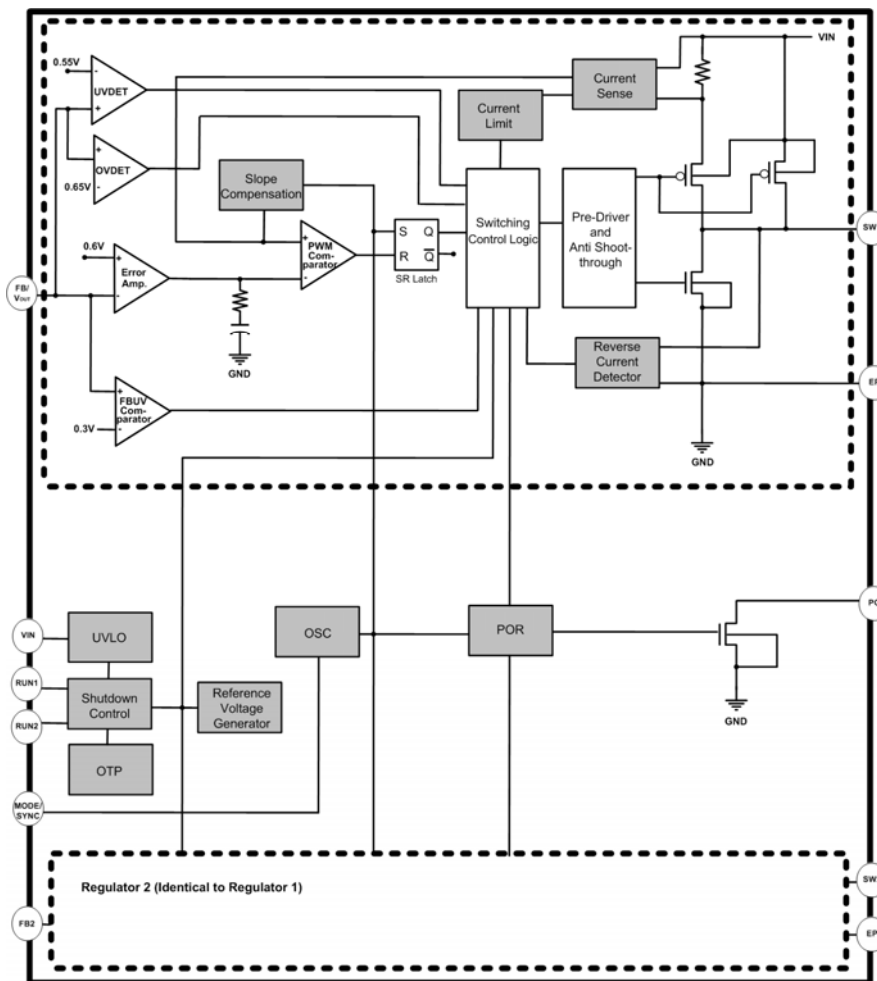

This datasheet contains new product information. Feeling Technology reserves the rights to modify the product specification without notice. No liability is assumed as a result of the use of this product. No rights under any patent accompany the sales of the product.

## Pin Descriptions

### MSOP-10L (EP)

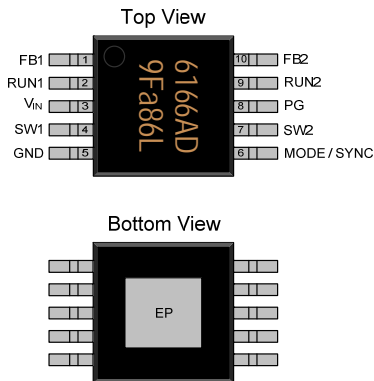

Name	No.	I / O	Description
FB1	1	I	First Channel Feedback
RUN1	2	I	First Channel Enable
V <sub>IN</sub>	3	P	IC Power Supply
SW1	4	O	First Channel Switch Output
GND	5	P	Ground
MODE / SYNC	6	I	Mode Selection, Oscillator Synchronization
SW2	7	O	Second Channel Switch Output
PG	8	O	Power Good
RUN2	9	I	Second Channel Enable
FB2	10	I	Second Channel Feedback
EP	11	P	Exposed PAD – connect to Ground

### DFN-10L(EP)

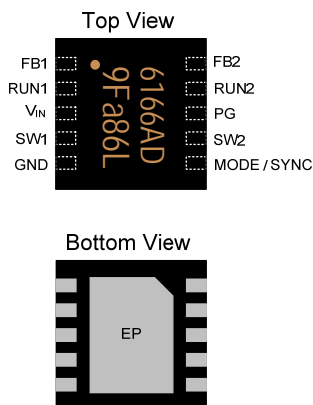

Name	No.	I / O	Description
FB1	1	I	First Channel Feedback
RUN1	2	I	First Channel Enable
V <sub>IN</sub>	3	P	IC Power Supply
SW1	4	O	First Channel Switch Output
GND	5	P	Ground
MODE / SYNC	6	I	Mode Selection, Oscillator Synchronization
SW2	7	O	Second Channel Switch Output
PG	8	O	Power Good
RUN2	9	I	Second Channel Enable
FB2	10	I	Second Channel Feedback
EP	11	P	Exposed PAD – connect to Ground

This datasheet contains new product information. Feeling Technology reserves the rights to modify the product specification without notice. No liability is assumed as a result of the use of this product. No rights under any patent accompany the sales of the product.

## Marking Information

### MSOP-10L(EP)

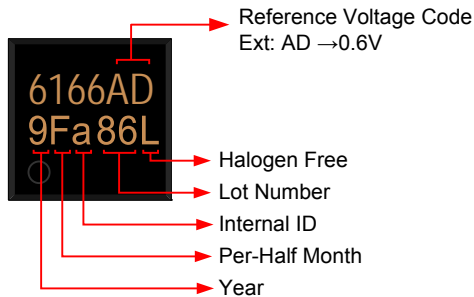

### DFN-10L(EP)

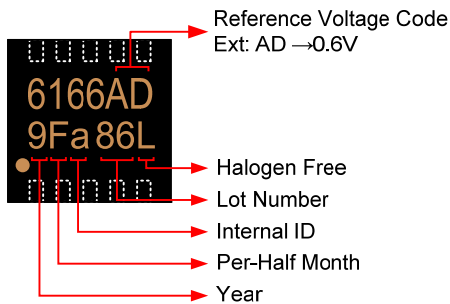

**Halogen Free:** Halogen free product indicator

**Lot Number:** Wafer lot number's last two digits

For Example: 132386TB → 86

**Internal ID:** Internal Identification Code

**Per-Half Month:** Production period indicated in half month time unit

For Example: January → A (Front Half Month), B (Last Half Month)

February → C (Front Half Month), D (Last Half Month)

**Year:** Production year's last digit

## Ordering Information

Part Number	Operating Temperature	Package	MOQ	Description
FP6166ADgR-G1	-40°C ~ +85°C	MSOP-10L (EP)	3000EA	Tape & Reel
FP6166ADdR-G1	-40°C ~ +85°C	DFN-10L (EP)	2500EA	Tape & Reel

## Absolute Maximum Ratings

Parameter	Symbol	Conditions	Min.	Typ.	Max.	Unit
Input Supply Voltage	$V_{IN}$		-0.3		6	V
RUN, $V_{FB}$ , SW Voltage			-0.3		$V_{IN}$	V
P-Channel Switch Source Current (DC)					1	A
N-Channel Switch Source Current (DC)					1	A
Peak SW Switch Sink and Source Current (AC)					2	A
Thermal Resistance (Junction to Ambient)	$\theta_{JA}$	MSOP-10L			+70	°C / W
		DFN-10L			+65	°C / W
Thermal Resistance (Junction to Case)	$\theta_{JC}$	MSOP-10L			+10	°C / W
		DFN-10L			+10	°C / W
Operating Temperature			-40		+85	°C
Junction Temperature					+150	°C
Storage temperature			-65		+150	°C
Lead Temperature (soldering, 10 sec)		MSOP-10L			+260	°C
		DFN-10L			+260	°C

This datasheet contains new product information. Feeling Technology reserves the rights to modify the product specification without notice. No liability is assumed as a result of the use of this product. No rights under any patent accompany the sales of the product.

**IR Re-flow Soldering Curve**

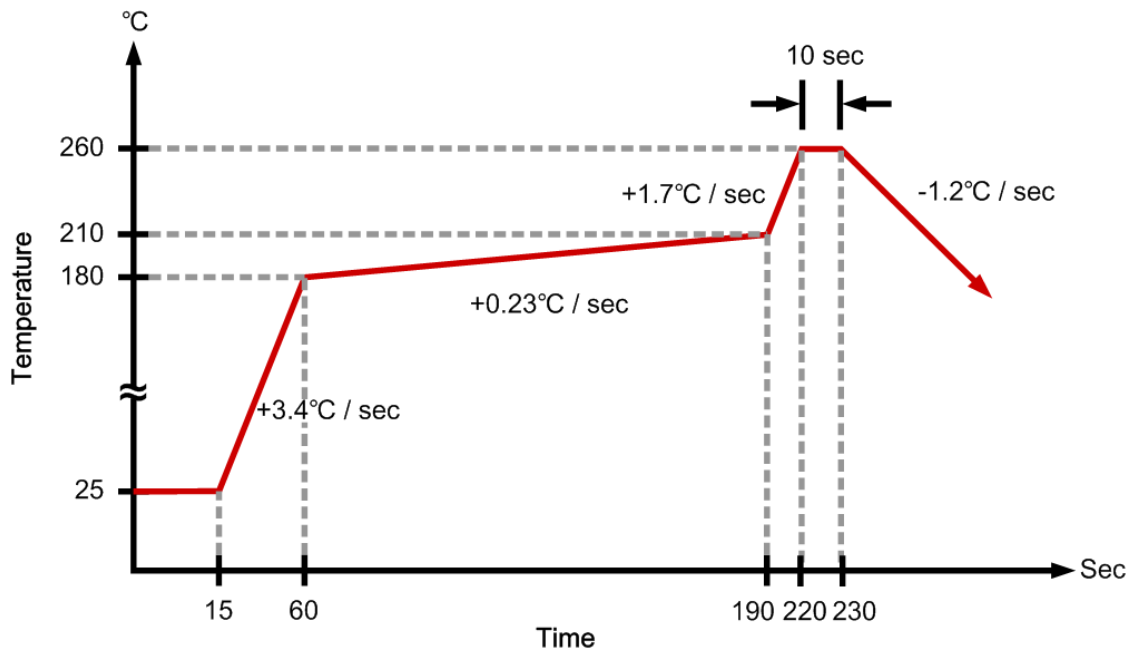

This datasheet contains new product information. Feeling Technology reserves the rights to modify the product specification without notice. No liability is assumed as a result of the use of this product. No rights under any patent accompany the sales of the product.

## Recommended Operating Conditions

Parameter	Symbol	Conditions	Min.	Typ.	Max.	Unit
Supply Voltage	$V_{IN}$		2.5		5.5	V
Operating Temperature			-40		+85	°C

## DC Electrical Characteristics ( $V_{IN}=3.6V$ , $T_A=25^{\circ}C$ , unless otherwise noted)

Parameter	Symbol	Conditions	Min.	Typ.	Max.	Unit
Regulated Feedback Voltage	$V_{FB}$	$T_A=25^{\circ}C$	0.588	0.6	0.612	V
		$-40^{\circ}C \sim +85^{\circ}C$	0.582	0.6	0.618	V
Line Regulation with $V_{REF}$	$\Delta V_{FB}$	$V_{IN}=2.5V$ to $5.5V$		0.04	0.4	% / V
Output Voltage Line Regulation	$\Delta V_{OUT}$	$V_{IN}=2.5$ to $5.5V$		0.04	0.4	% / V
RDS (ON) of P-Channel FET	$R_{DS(ON)P}$	$I_{SW}=100mA$		0.28	0.35	$\Omega$
RDS (ON) of N-Channel FET	$R_{DS(ON)N}$	$I_{SW}=-100mA$		0.25	0.32	$\Omega$
SW Leakage	$I_{LSW}$	$V_{RUN}=0V$ , $V_{IN}=5V$		$\pm 0.01$	$\pm 1$	$\mu A$
Peak Inductor Current	$I_{PK}$	$V_{FB}=0.5V$	1.125	1.5	1.875	A
Input Voltage Range	$V_{IN}$		2.5		5.5	V
Quiescent Current	$I_{CC}$	Shutdown, $V_{RUN}=0V$		0.1	1	$\mu A$
		Active, $V_{FB}=0.5V$ , $V_{RUN}=V_{IN}$		190		$\mu A$
		PFM, $V_{FB}=0.7V$ , $V_{RUN}=V_{IN}$		150		$\mu A$
RUN Threshold	$V_{RUN}$		0.3	1	1.5	V
RUN Leakage Current	$I_{RUN}$			$\pm 0.01$	$\pm 1$	$\mu A$
Oscillator Frequency	$F_{OSC}$	$V_{FB}=0.6V$	1.2	1.5	1.8	MHz

This datasheet contains new product information. Feeling Technology reserves the rights to modify the product specification without notice. No liability is assumed as a result of the use of this product. No rights under any patent accompany the sales of the product.

Typical Operating Characteristics ( $V_{IN}=3.6V, T_A=25^\circ C$ , unless otherwise noted)

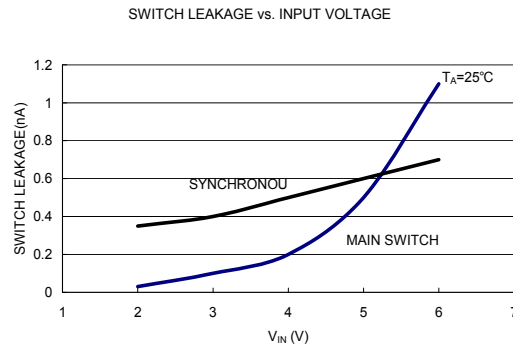
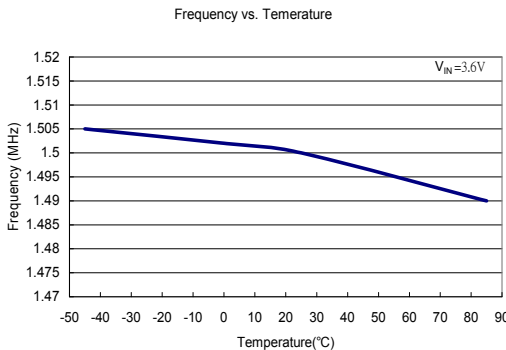
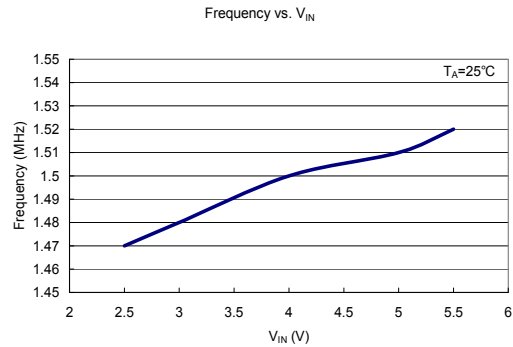
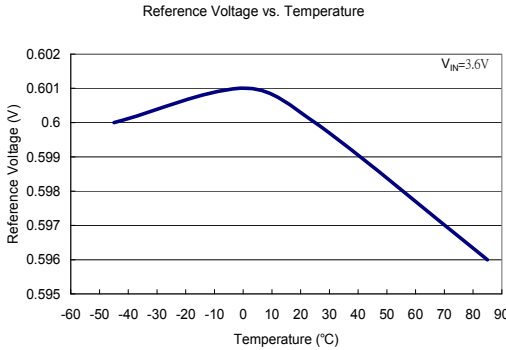
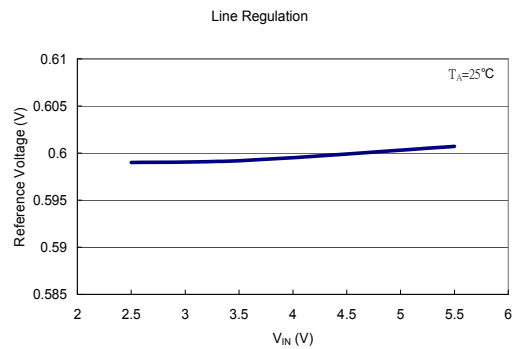
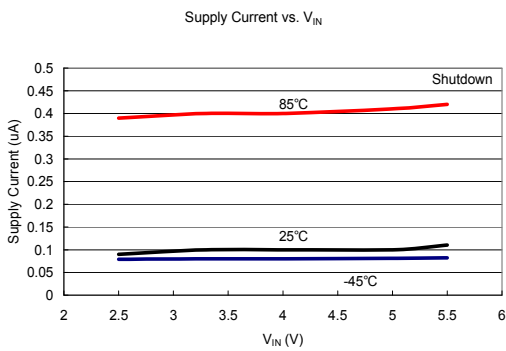
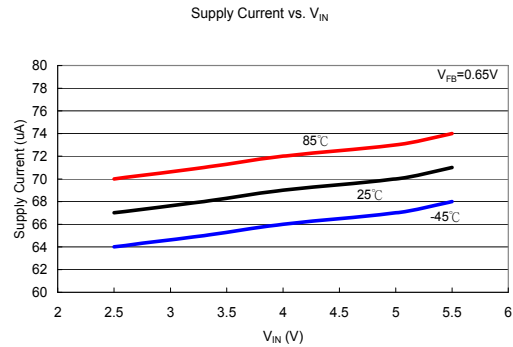
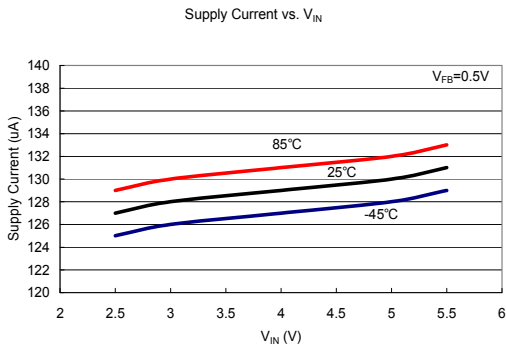

This datasheet contains new product information. Feeling Technology reserves the rights to modify the product specification without notice. No liability is assumed as a result of the use of this product. No rights under any patent accompany the sales of the product.



## Function Description

### Control Loop

The FP6166 is a high efficiency current mode dual synchronous buck regulators. Both the main (P-channel MOSFET) and synchronous (N-channel MOSFET) switches are built internally. With current mode operation, the PWM duty is controlled both by the error amplifier output and the peak inductor current. At the beginning of each cycle, the oscillator turn on the P-MOSFET switch to source current from  $V_{IN}$  to SW output. Then, the chip starts to compare the inductor current with the error amplifier output. Once the inductor current is larger than the error amplifier output, the P-MOSFET switch is turned off. When the load current increases, the feedback voltage FB will slightly drop. This causes the error amplifier to output a higher current level until the prior mentioned peak inductor current reach the same level. The output voltage then can be sustained at the same.

When the top P-MOSFET switch is off, the bottom synchronous N-MOSFET switch is turned on. Once the inductor current reverses, both top and bottom MOSFET will be turn off to leave the SW pin into high impedance state.

The FP6166's current mode control loop also contains slope compensation to suppress sub-harmonic oscillations at high duty cycles. This slope compensation is achieved by adding a compensation ramp to the inductor current signal.

### LDO Mode

The FP6166's maximum duty cycle can reach 100%. That means the driver main switch is turn on through out whole clock cycle. Once the duty reaches 100%, the feedback path no longer controls the output voltage. The output voltage will be the input voltage minus the main switch voltage drop.

### Power Good

A common-drain pin is built into FP6166 to output the power good signal. When the output voltage is not within  $\pm 8.5\%$  of regulation, FP6166 will pull its POR output pin to ground. After both channels' outputs go within regulation, the POR output pin will be released after 175ms.

### Mode Selection

User can select pulse skip mode or pulse frequency modulation operation in light loading by connecting MODE / SYNC pin to  $V_{IN}$  or GND. Pulse frequency modulation provides better conversion efficiency with the penalty of a little larger output ripple, which is around double than the PWM mode's one.

**Synchronous Mode**

When the MODE / SYNC pin is connected to a clock, chip's SW outputs will be synchronized to it automatically. The synchronous range is from 0.5~1.5 time input clock frequency. In this mode, pulse skip mode is selected automatically.

**Over Current Protection**

FP6166 limits the peak main switch current cycle by cycle. When over current happens, chip will turn off the main switch and turn the synchronous switch on until next cycle.

**Short Circuit Protection**

When the FB pin drops below 300mV, the chip will tri-state the output pin SW automatically. After 300us rest to avoid over heating, chip will re-initiate PWM operation with soft start.

**Thermal Protection**

FP6166 will shutdown automatically when the internal junction temperature reaches 150°C to protect both the part and the system.

## Application Information

### Input capacitor Selection

The input capacitor must be connected to the VIN pin and GND pin of the FP6166 to maintain steady input voltage and filter out the pulsing input current. The voltage rating of input capacitor must be greater than maximum input voltage plus ripple voltage.

In switch mode, the input current is discontinuous in a buck converter. The source current of the high-side MOSFET is a square wave. To prevent large voltage transients, a low ESR input capacitor sized for the maximum RMS current must be used. The RMS value of input capacitor current can be calculated by:

$$I_{\text{RMS}} = I_{\text{O\_MAX}} \sqrt{\frac{V_{\text{O}}}{V_{\text{IN}}} \left(1 - \frac{V_{\text{O}}}{V_{\text{IN}}}\right)}$$

It can be seen that when  $V_{\text{O}}$  is half of  $V_{\text{IN}}$ ,  $C_{\text{IN}}$  is under the worst current stress. The worst current stress on  $C_{\text{IN}}$  is  $I_{\text{O\_MAX}}/2$ .

### Inductor Selection

The value of the inductor is selected based on the desired ripple current. Large inductance gives low inductor ripple current and small inductance result in high ripple current. However, the larger value inductor has a larger physical size, higher series resistance, and/or lower saturation current. In experience, the value is to allow the peak-to-peak ripple current in the inductor to be 10%~20% maximum load current. The inductance value can be calculated by:

$$L = \frac{(V_{\text{IN}} - V_{\text{O}}) V_{\text{O}}}{f \times \Delta I_{\text{L}}} = \frac{(V_{\text{IN}} - V_{\text{O}}) V_{\text{O}}}{f \times [2 \times (10\% \sim 20\%) I_{\text{O}}]}$$

The inductor ripple current can be calculated by:

$$\Delta I_{\text{L}} = \frac{V_{\text{O}}}{f \times L} \times \left(1 - \frac{V_{\text{O}}}{V_{\text{IN}}}\right)$$

Choose an inductor that does not saturate under the worst-case load conditions, which is the load current plus half the peak-to-peak inductor ripple current, even at the highest operating temperature. The peak inductor current is:

$$I_{\text{L\_PEAK}} = I_{\text{O}} + \frac{\Delta I_{\text{L}}}{2}$$

The inductors in different shape and style are available from manufacturers. Shielded inductors are small and radiate less EMI issue. But they cost more than unshielded inductors. The choice depends on EMI requirement, price and size.

Inductor Value (μH)	Dimensions (mm)	Component Supplier	Model
2.2	4.2×3.7×1.2	FENG-JUI	TP4212-2R2M
2.2	4.4×5.8×1.2	Sumida	CMD4D11 2R2
3.3	4.2×3.7×1.2	FENG-JUI	TP4212-3R3M
4.7	4.2×3.7×1.2	FENG-JUI	TP4212-4R7M
4.7	4.4×5.8×1.2	Sumida	CMD4D11 4R7
4.7	4.9×4.9×1.0	Sumida	CLSD09 4R7

### Output Capacitor Selection

The output capacitor is required to maintain the DC output voltage. Low ESR capacitors are preferred to keep the output voltage ripple low. In a buck converter circuit, output ripple voltage is determined by inductor value, switching frequency, output capacitor value and ESR. The output ripple is determined by:

$$\Delta V_O = \Delta I_L \times \left( \text{ESR}_{\text{COUT}} + \frac{1}{8 \times f \times C_{\text{OUT}}} \right)$$

Where f = operating frequency, COUT= output capacitance and ΔIL = ripple current in the inductor. For a fixed output voltage, the output ripple is highest at maximum input voltage since ΔIL increases with input voltage.

Capacitor Value	Case Size	Component Supplier	Model
4.7	0603	TDK	C1608JB0J475M
10	0805	Taiyo Yuden	JMK212BJ106MG
10	0805	TDK	C12012X5ROJ106K
22	0805 1206	TDK	C2012JB0J226M

### Using Ceramic Input and Output Capacitors

Care must be taken when ceramic capacitors are used at the input and the output. When a ceramic capacitor is used at the input and the power is supplied by a wall adapter through long wires, a load step at the output can induce ringing at the input,  $V_{IN}$ . At best, this ringing can couple to the output and be mistaken as loop instability. At worst, a sudden inrush of current through the long wires can potentially cause a voltage spike at  $V_{IN}$ , large enough to damage the part. When choosing the input and output ceramic capacitors, choose the X5R or X7R dielectric formulations. These dielectrics have the best temperature and voltage characteristics of all the ceramics for a given value and size.

---

This datasheet contains new product information. Feeling Technology reserves the rights to modify the product specification without notice. No liability is assumed as a result of the use of this product. No rights under any patent accompany the sales of the product.

## Output Voltage Programming

In the adjustable version, the output voltage is set using a resistive voltage divider from the output voltage to FB. The output voltage is:

$$V_O = 0.6V \left( 1 + \frac{R_1}{R_2} \right)$$

The recommended resistor value is summarized below:

$V_{OUT}$ (V)	$R_1$ ( $\Omega$ )	$R_2$ ( $\Omega$ )	$C_3$ (F)
0.6	200k	Not Used	Not Used
1.2	200k	200k	10p
1.5	300k	200k	10p
1.8	200k	100k	10p
2.5	270k	85k	10p
3.3	306k	68k	10p

## PC Board Layout Checklist

1. The power traces, consisting of the GND trace, the SW trace and the  $V_{IN}$  trace should be kept short, direct and wide.
2. Place  $C_{IN}$  near  $V_{IN}$  Pin as closely as possible. To maintain input voltage steady and filter out the pulsing input current.
3. The resistive divider  $R_1$  and  $R_2$  must be connected to FB pin directly as closely as possible.
4. FB is a sensitive node. Please keep it away from switching node, SW. A good approach is to route the feedback trace on another layer and to have a ground plane between the top layer and the layer on which the feedback trace is routed. This reduces EMI radiation on to the DC-DC converter's own voltage feedback trace.
5. Keep the GND plates of  $C_{IN}$  and  $C_{OUT}$  as close as possible. Then connect this to the ground-plane (if one is used) with several vias. This reduces ground plane noise by preventing the switching currents from circulating through the ground plane. It also reduces ground bounce at the FP6166 by giving it a low impedance ground connection.

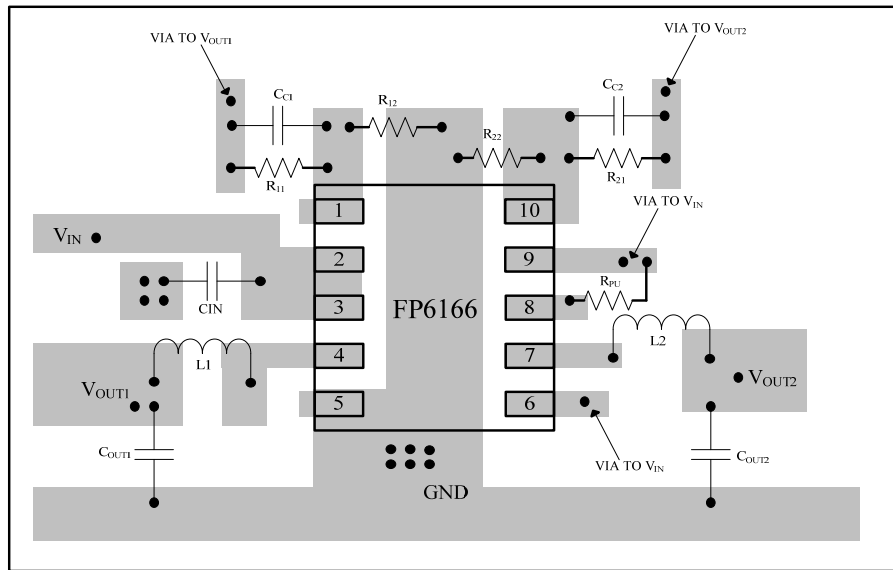

Suggested Layout

This datasheet contains new product information. Feeling Technology reserves the rights to modify the product specification without notice. No liability is assumed as a result of the use of this product. No rights under any patent accompany the sales of the product.

## Typical Application

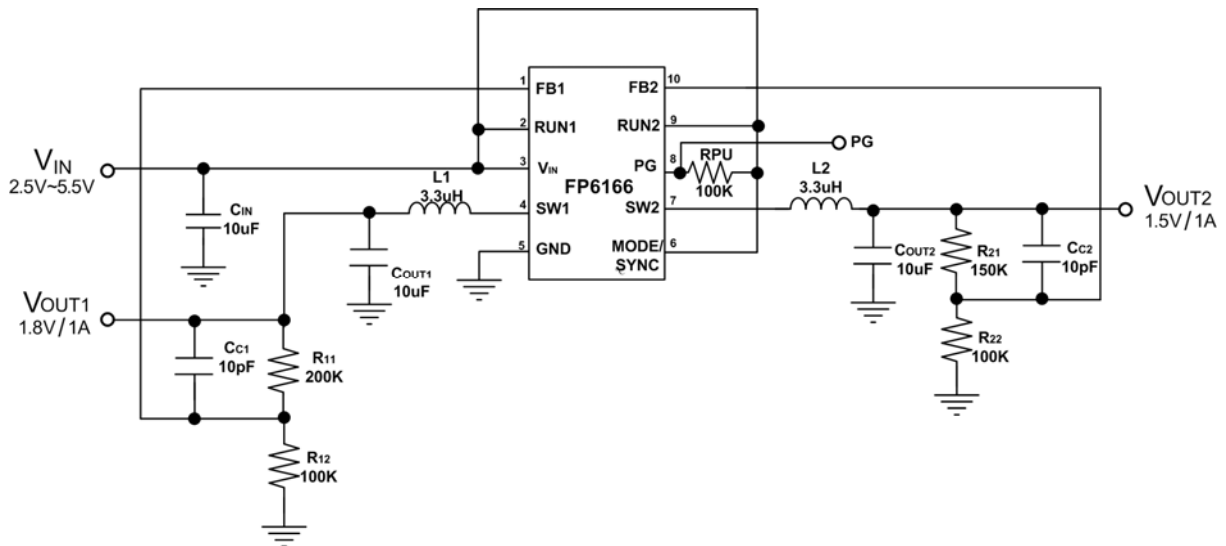

This datasheet contains new product information. Feeling Technology reserves the rights to modify the product specification without notice. No liability is assumed as a result of the use of this product. No rights under any patent accompany the sales of the product.

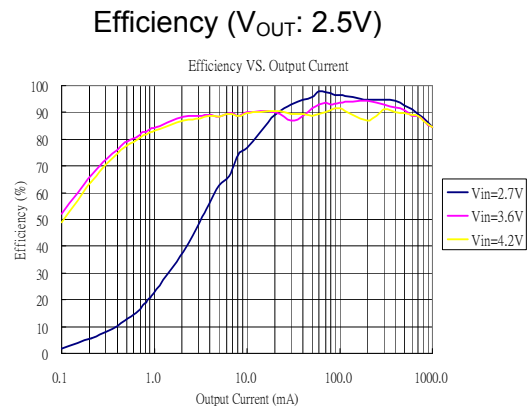
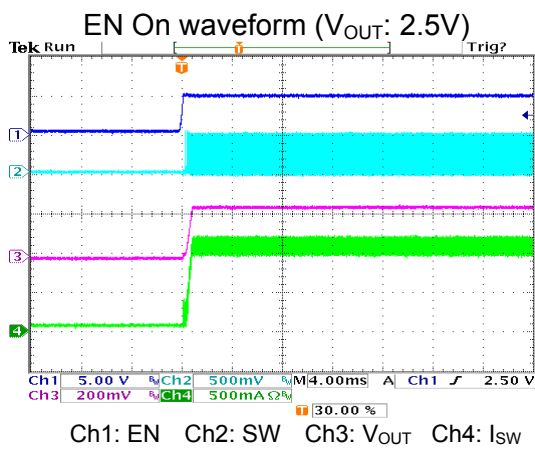
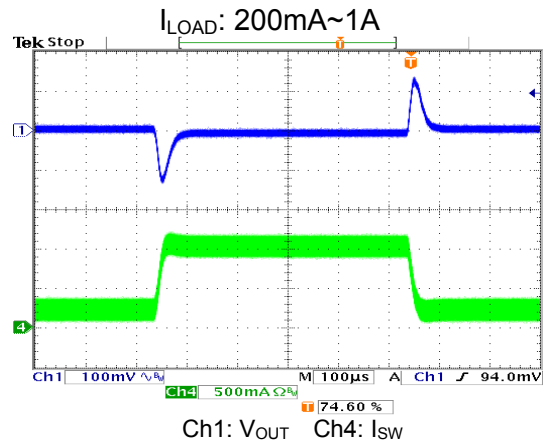
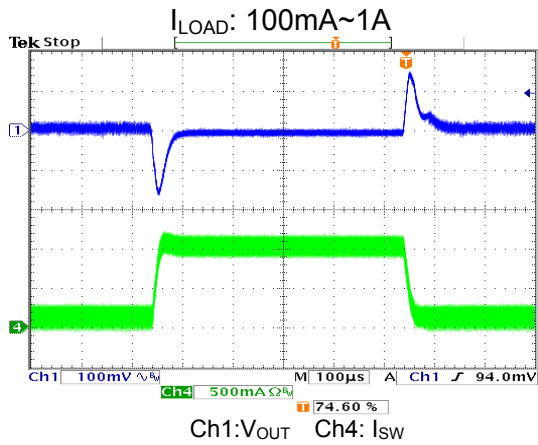

This datasheet contains new product information. Feeling Technology reserves the rights to modify the product specification without notice. No liability is assumed as a result of the use of this product. No rights under any patent accompany the sales of the product.



## Package Outline

### MSOP-10L (EP)

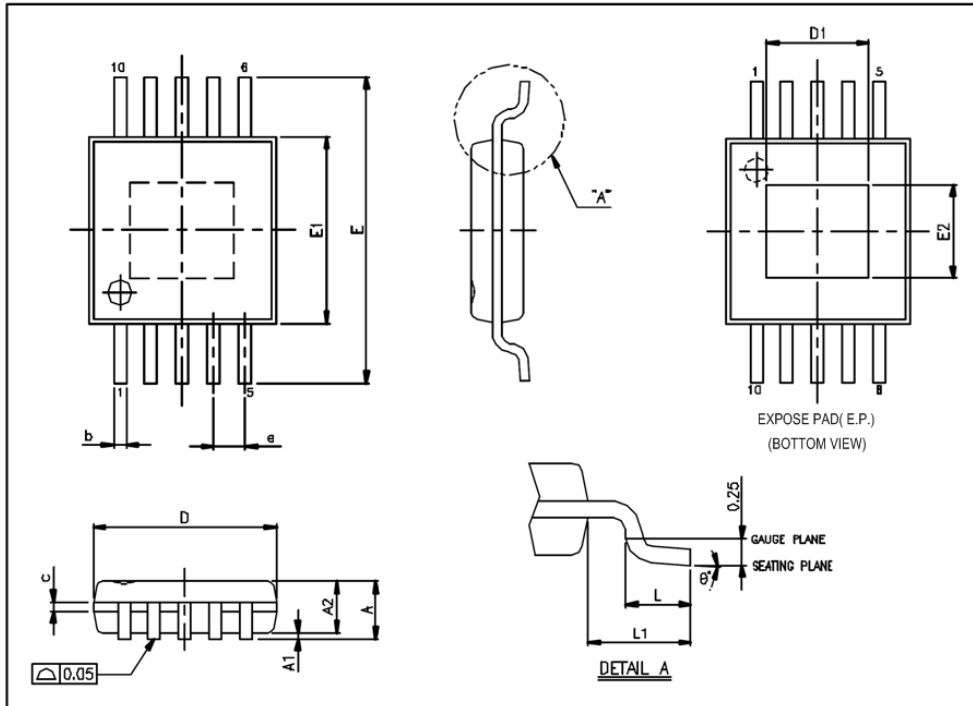
**UNIT: mm**

Symbols	Min. (mm)	Max. (mm)
A		1.100
A1	0.000	0.150
A2	0.750	0.950
b	0.170	0.270
c	0.080	0.230
D	3.000 BSC.	
E	4.900 BSC.	
E1	3.000 BSC.	
e	0.500 BSC.	
L	0.400	0.800
L1	0.950 REF.	
$\theta$	0°	8°

This datasheet contains new product information. Feeling Technology reserves the rights to modify the product specification without notice. No liability is assumed as a result of the use of this product. No rights under any patent accompany the sales of the product.

## MSOP-10L (EP) continued

Exposed PAD Dimensions:

Symbols	Min. (mm)	Max. (mm)
E2		1.715 REF
D1		1.600 REF

**Note:**

1. Package dimensions are in compliance with JEDEC outline: MO-187 BA-T.
2. Dimension “D” does not include molding flash, protrusions or gate burrs.
3. Dimension “E1” does not include inter-lead flash or protrusions.

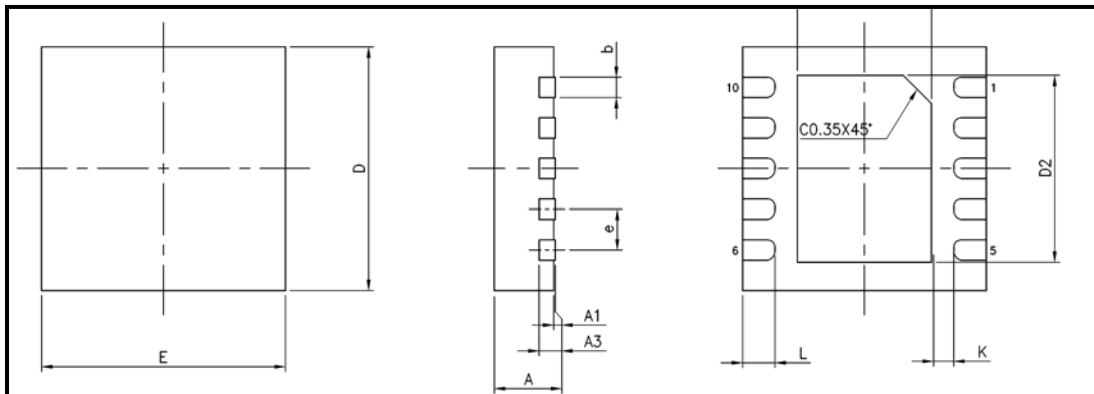
**DFN-10L**

**UNIT: mm**

Symbols	Min. (mm)	Max. (mm)
A	0.700	0.800
A1	0.000	0.050
A3	0.20REF	
b	0.180	0.300
D	3.00	
E	3.00	
D2	2.200	2.700
E2	1.400	1.750
e	0.500	
L	0.300	0.500
K	0.200	

This datasheet contains new product information. Feeling Technology reserves the rights to modify the product specification without notice. No liability is assumed as a result of the use of this product. No rights under any patent accompany the sales of the product.