

3A, 23V, 380KHz Step-Down Converter

Halogen
Free

General Description

The FP6180 is a buck regulator with a built in internal power MOSFET. It achieves 3A continuous output current over a wide input supply range with excellent load and line regulation. Current mode operation provides fast transient response and eases loop stabilization. The device includes cycle-by-cycle current limiting and thermal shutdown protection. Adjustable soft-start reduced the stress on the input source at power-on. The regulator only consumes 20 μ A supply current in shutdown mode. The FP6180 requires a minimum number of readily available external components to complete a 3A buck regulator solution.

Features

- 3A Output Current
- Adjustable Soft-Start
- 0.1 Ω Internal Power MOSFET Switch
- Stable with Low ESR Output Ceramic Capacitors
- Up to 95% Efficiency
- 20 μ A Shutdown Mode Current
- Fixed 380KHz Frequency
- Thermal Shutdown
- Cycle-by-Cycle Over Current Protection
- Wide 4.75 to 23V Operating Input Range
- Output Adjustable From 1.22 to 21V
- Available SOP-8L (EP) Package
- Under Voltage Lockout

Applications

- Distributed Power Systems
- Battery Charger
- Pre-Regulator for Linear Regulators

Typical Application Circuit

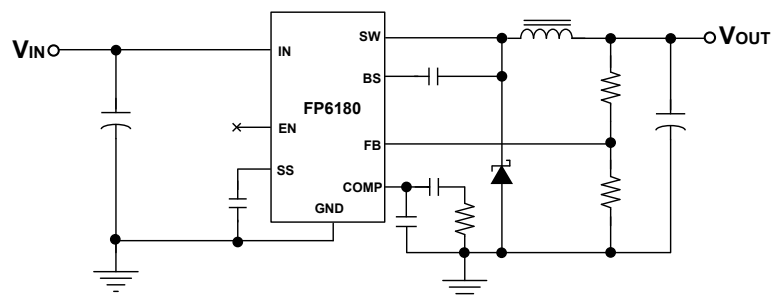

This datasheet contains new product information. Feeling Technology reserves the rights to modify the product specification without notice. No liability is assumed as a result of the use of this product. No rights under any patent accompany the sales of the product.

Function Block Diagram

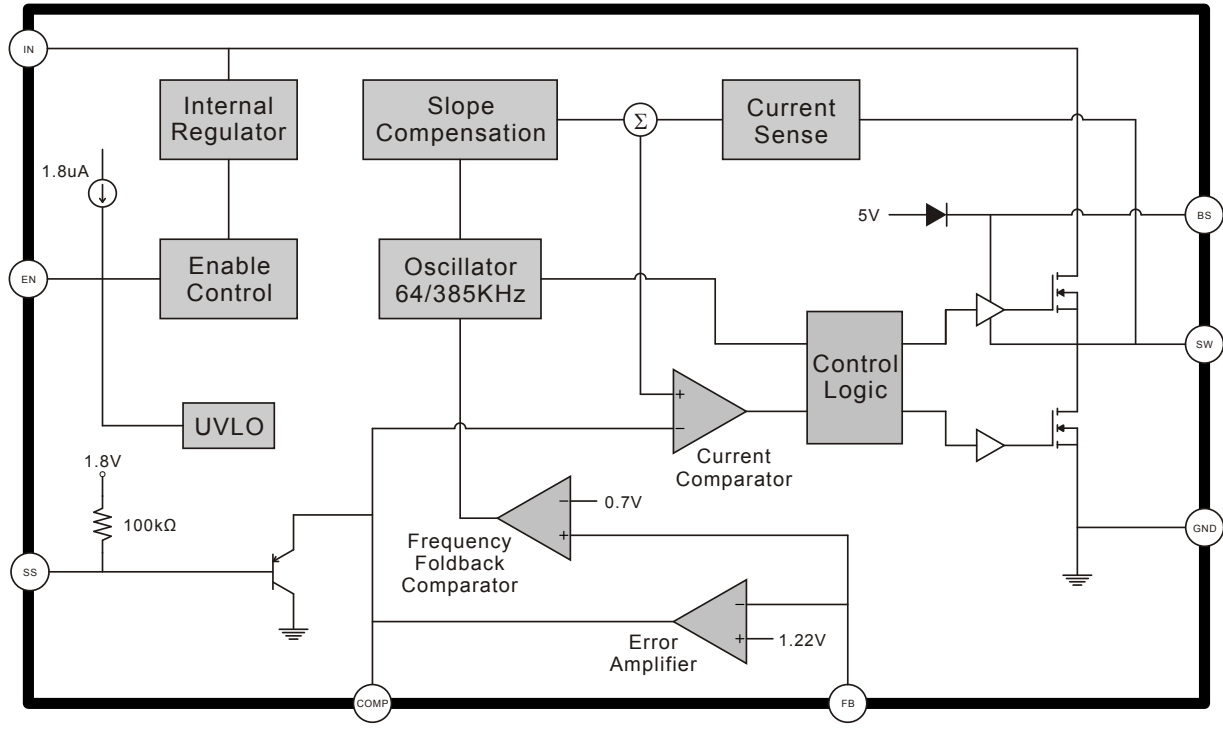

Pin Descriptions

SOP-8L (EP)

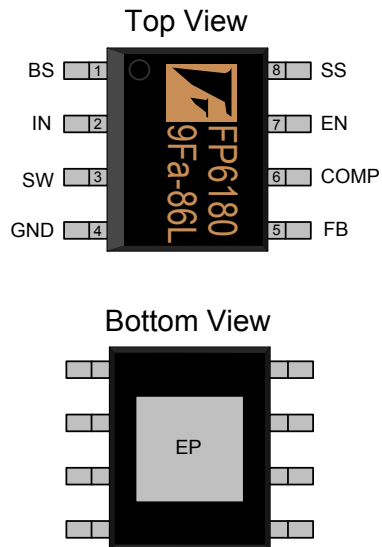

Name	No.	I / O	Description
BS	1	I	Bootstrap
IN	2	P	Supply Voltage
SW	3	O	Switch
GND	4	P	Ground
FB	5	I	Feedback
COMP	6	O	Compensation
EN	7	I	Enable / UVLO
SS	8	I	Programmable Soft Start
EP	9	P	Exposed PAD is GND

This datasheet contains new product information. Feeling Technology reserves the rights to modify the product specification without notice. No liability is assumed as a result of the use of this product. No rights under any patent accompany the sales of the product.

Marking Information

SOP-8L (EP)

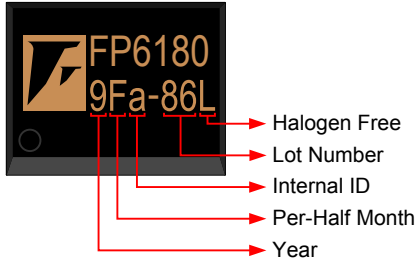

Halogen Free: Halogen free product indicator

Lot Number: Wafer lot number's last two digits

For Example: 132386TB → 86

Internal ID: Internal Identification Code

Per-Half Month: Production period indicated in half month time unit

For Example: January → A (Front Half Month), B (Last Half Month)

February → C (Front Half Month), D (Last Half Month)

Year: Production year's last digit

Ordering Information

Part Number	Operating Temperature	Package	MOQ	Description
FP6180XR-G1	-40°C ~ +85°C	SOP-8L (EP)	2500EA	Tape & Reel

Absolute Maximum Ratings

Parameter	Symbol	Conditions	Min.	Typ.	Max.	Unit
Supply Voltage	V_{IN}		-0.3		24	V
Supply Voltage	V_{SW}		-1		$V_{IN} + 0.3$	V
Boost Voltage	V_{BS}		$V_{SW} - 0.3$		$V_{SW} + 6$	V
All Other Pins			-0.3		6	V
Thermal Resistance, Lead	θ_{JA}	SOP-8L (EP)			60	°C / W
	θ_{JC}	SOP-8L (EP)			10	°C / W
Junction Temperature					150	°C
Storage Temperature			-65		150	°C
Operating Temperature			-40		85	°C
Lead Temperature (soldering, 10 sec)		SOP-8L (EP)			260	°C

IR Re-flow Soldering Curve

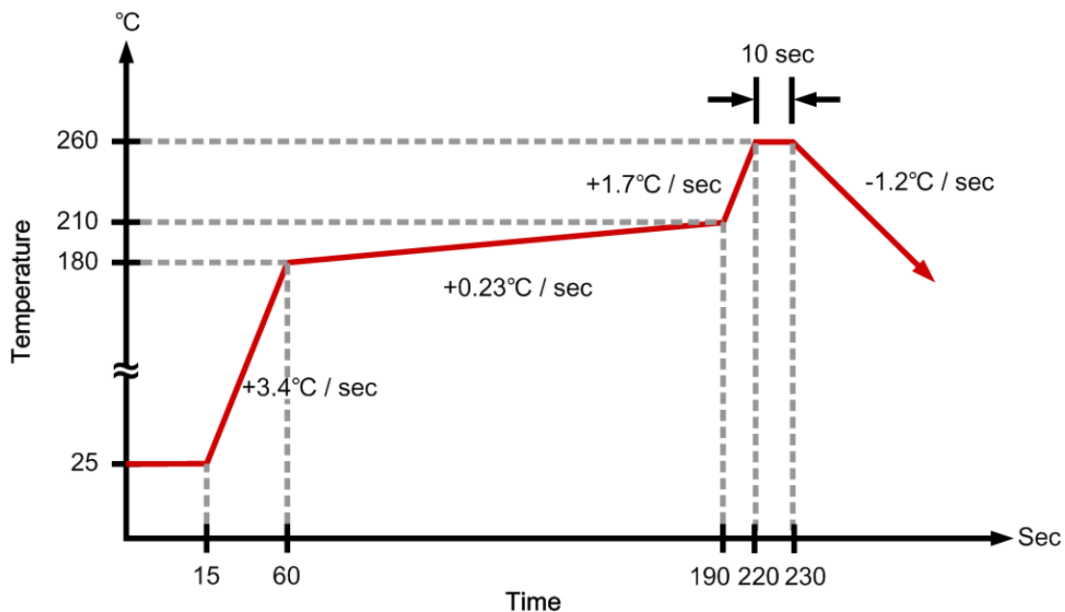

This datasheet contains new product information. Feeling Technology reserves the rights to modify the product specification without notice. No liability is assumed as a result of the use of this product. No rights under any patent accompany the sales of the product.

Recommended Operating Conditions

Parameter	Symbol	Conditions	Min.	Typ.	Max.	Unit
Supply Voltage	V_{IN}		4.75		23	V
Operating Temperature			-40		+85	°C

DC Electrical Characteristics ($V_{IN}=3.6V$, $T_A= 25^{\circ}C$, unless otherwise noted)

Parameter	Symbol	Conditions	Min.	Typ.	Max.	Unit
Shutdown Supply Current	I_{ST}	$V_{EN}=0$		20	30	μA
Supply Current	I_{CC}	$V_{EN}=2.6$, $V_{FB}=1.4$		1	1.2	mA
Feedback Voltage	V_{FB}	$V_{IN}=12V$, $V_{COMP}<2V$	1.194	1.222	1.25	V
Error Amplifier Voltage Gain	G_{EA}			400		V / V
Error Amplifier Tran Conductance		$\Delta IC=\pm 10\mu A$	500	800		$\mu A / V$
High Side Switch ON Resistance	R_{ON-HS}			0.1		
Low Side Switch ON Resistance	R_{ON-LS}			10		
High Side Switch Leakage Current	I_{IL}	$V_{EN}=0$, $V_{SW}=0V$		0.1	10	μA
Current Limit	I_{CL}			5.5		A
Current Sense to COMP Tran Conductance				4.4		A / V
Oscillation Frequency	F_{OSC}		327	385	450	KHz
Short Circuit Oscillation Frequency		$V_{FB}=0V$	40	64	88	KHz
Maximum Duty Cycle		$V_{FB}=1.0V$		90		%
Minimum Duty Cycle		$V_{FB}=1.5V$			0	%
Under Voltage Lockout Threshold	V_{UVLO}	V_{EN} Rising	2.37	2.54	2.71	V
Under Voltage Lockout Threshold Hysteresis	V_{HYS}			210		mV
EN Threshold Voltage	V_{EN}		0.9	1.2	1.5	V
EN Threshold Voltage	I_{EN}	$V_{EN}=0V$	1.1	1.8	3	μA
Soft Start Period	V_{SS}	$C_{SS}=0.1 \mu F$		10		ms
Thermal Shutdown	T_{TS}			150		°C

Typical Operating Characteristics

($V_{IN}=12V$, $T_A=25^{\circ}C$, unless otherwise noted)

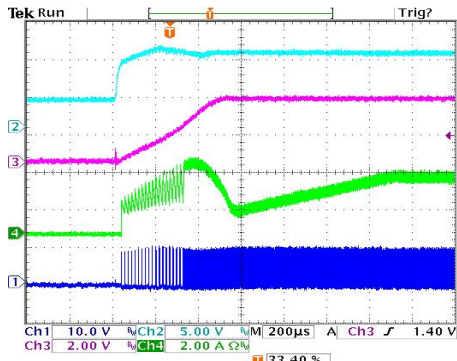

Figure 1: Power on

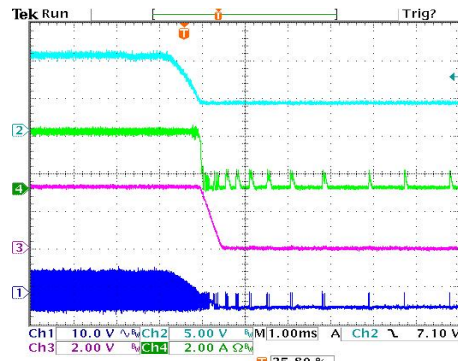

Figure 2: Power off

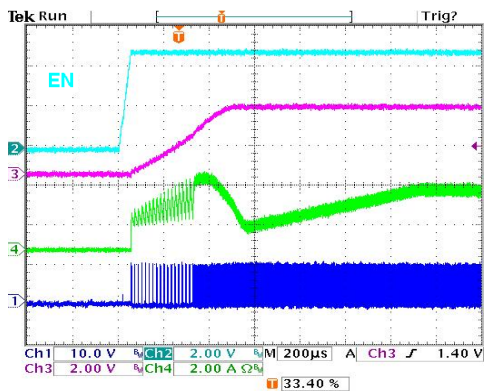

Figure 3: EN Pin Enable

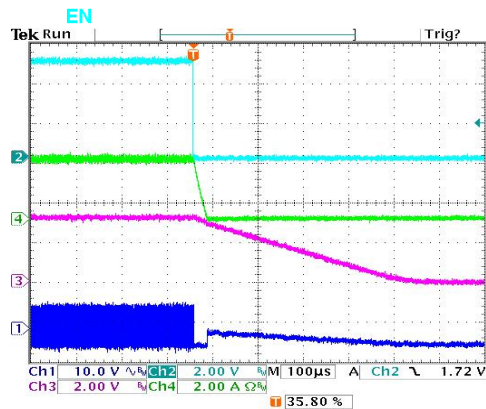

Figure 4: EN Pin Disable

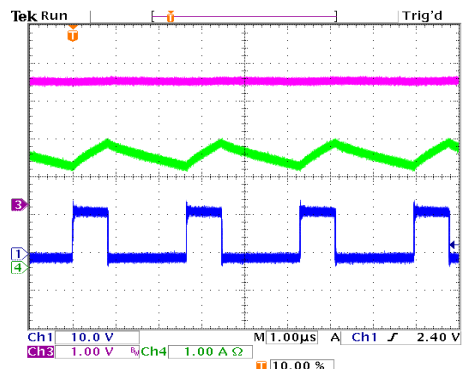

Figure 5: Load 3A

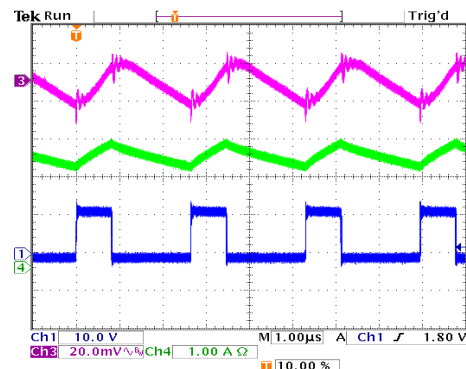

Figure 6: Load 3A Ripple

This datasheet contains new product information. Feeling Technology reserves the rights to modify the product specification without notice. No liability is assumed as a result of the use of this product. No rights under any patent accompany the sales of the product.

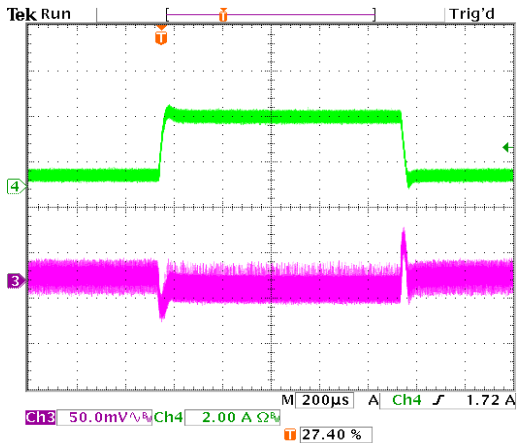

Figure 7: Load Step

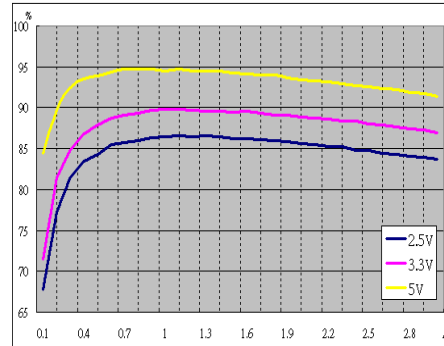

Figure 8: Efficiency vs Load (Vin=7V)

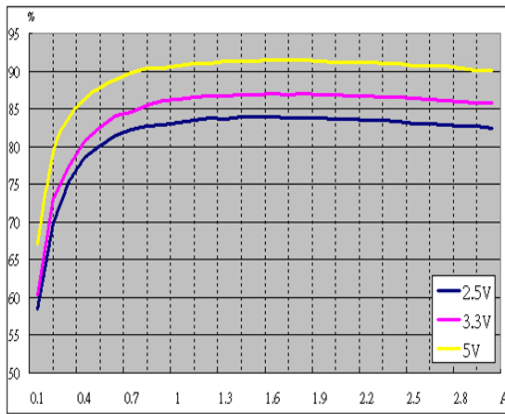

Figure 9: Efficiency vs Load (Vin=10V)

Function Description

The FP6180 is a current-mode buck regulator. It regulates input voltages from 4.75V to 23V down to an output voltage as low as 1.22V, and is able to supply up to 3A of load current. The FP6180 uses current-mode control to regulate the output voltage. The output voltage is measured at FB through a resistive voltage divider and amplified through the internal error amplifier. The output current of the Transconductance error amplifier is presented at COMP where a network compensates the regulation control system. The voltage at COMP is compared to the switch current measured internally to control the output voltage.

The converter uses an internal n-channel MOSFET switch to step-down the input voltage to the regulated output voltage. Since the MOSFET requires a gate voltage greater than the input voltage, a bootstrap capacitor connected between SW and BS drives the gate. The capacitor is internally charged while the switch is off. An internal 10Ω switch from SW to GND is used to insure that SW is pulled to GND when the switch is off to fully charge the BS capacitor.

Output Voltage (V_{OUT})

The output voltage is set using a resistive voltage divider from the output voltage to FB. The voltage divider divides the output voltage down by the ratio:

$$V_{FB} = V_{OUT} \times \frac{R_4}{R_2 + R_4}$$

Thus the output voltage is:

$$V_{OUT} = V_{FB} \times \frac{R_2 + R_4}{R_4}$$

A typical value for R4 can be as high as 100k, but a typical value is 10K.

Shutdown Mode

Drive Enable Pin to ground to shut down the FP6180. Shutdown forces the internal power MOSFET off, turns off all internal circuitry, and reduces the V_{IN} supply current to 20μA (typ). The enable Pin rising threshold is 1.2V (typ). Before any operation begins, the voltage at Enable Pin must exceed 1.2V (typ). The Enable Pin input has 100mV hysteresis.

Boost High-Side Gate Drive (BST)

Since the MOSFET requires a gate voltage greater than the input voltage, connect a flying bootstrap capacitor between SW and BS to provide the gate-drive voltage to the high-side n-channel MOSFET switch. The capacitor is alternately charged from the internally regulated output voltage.

On startup, an internal low-side switch connects SW to ground and charges the BST capacitor to the internally regulated output voltage. Once the BST capacitor is charged, the internal low-side switch is turned off.

off and the BST capacitor voltage provides the necessary enhancement voltage to turn on the high-side switch.

Thermal Shutdown Protection

The FP6180 features integrated thermal shutdown protection. Thermal shutdown protection limits allowable power dissipation (PD) in the device, and protects the device in the event of a fault condition. When the IC junction temperature exceeds +150°C, an internal thermal sensor signals the shutdown logic, turning off the internal power MOSFET and allowing the IC to cool down. The thermal sensor turns the internal power MOSFET back on after the IC junction temperature cools down to +110°C resulting in a pulsed output under continuous thermal overload conditions.

Application Information

Input Capacitor Selection

The input current to the step-down converter is discontinuous, therefore a capacitor is required to supply the AC current to the step-down converter while maintaining the DC input voltage. Use low ESR capacitors for the best performance. Ceramic capacitors are preferred, but tantalum or low-ESR electrolytic capacitors may also suffice.

The input capacitor can be electrolytic, tantalum or ceramic. When using electrolytic or tantalum capacitors, a small, high quality ceramic capacitor, i.e. 0.1µF, should be placed as close to the IC as possible.

When using ceramic capacitors, make sure that they have enough capacitance to provide sufficient charge to prevent excessive voltage ripple at input. The input voltage ripple caused by capacitance can be estimated by

$$C_{IN} = \frac{I_o}{f \times \Delta V_{IN}} \times D(1-D)$$

Inductor Selection

The inductor is required to supply constant current to the output load while being driven by the switched input voltage. A larger value inductor will result in less ripple current that will result in lower output ripple voltage. However, the larger value inductor will have a larger physical size, higher series resistance, and / or lower saturation current. A good rule for determining the inductance to use is to allow the peak-to-peak ripple current in the inductor to be approximately 30% of the maximum switch current limit. Also, make sure that the peak inductor current is below the maximum switch current limit.

This datasheet contains new product information. Feeling Technology reserves the rights to modify the product specification without notice. No liability is assumed as a result of the use of this product. No rights under any patent accompany the sales of the product.

The inductance value can be calculated by

$$L = \frac{V_O + V_D}{I_O \gamma f} (1 - D)$$

Where r is the ripple current ratio

$$\text{RMS current in inductor } I_{L_{\text{rms}}} = I_O \sqrt{1 + \frac{\gamma^2}{12}}$$

Output Capacitor Selection

The output capacitor is required to maintain the DC output voltage. Ceramic, tantalum, or low ESR electrolytic capacitors are recommended. Low ESR capacitors are preferred to keep the output voltage ripple low. The output voltage ripple can be estimated by:

$$\Delta V_{\text{OUT}} = \frac{V_{\text{OUT}} \times (V_{\text{IN}} - V_{\text{OUT}})}{f \times L \times V_{\text{IN}}} \times \left(\text{ESR} + \frac{1}{8 \times f \times C_{\text{OUT}}} \right)$$

In the case of ceramic capacitors, the impedance at the switching frequency is dominated by the capacitance. The output voltage ripple is mainly caused by the capacitance. In the case of tantalum or electrolytic capacitors, the ESR dominates the impedance at the switching frequency.

I .In the case of ceramic capacitors

$$C_{\text{OUT}} = \frac{V_{\text{OUT}}}{8 \times f^2 \times L \times \Delta V_{\text{OUT}}} \times \left(1 - \frac{V_{\text{OUT}}}{V_{\text{IN}}} \right)$$

II .In the case of tantalum or electrolytic capacitors

$$\text{ESR} = \frac{\Delta V_{\text{OUT}} \times f \times L \times V_{\text{IN}}}{V_{\text{OUT}} \times (V_{\text{IN}} - V_{\text{OUT}})}$$

PC Board Layout Checklist

1. The power traces, consisting of the GND trace, the SW trace and the V_{IN} trace should be kept short, direct and wide.
2. Place C_{IN} near IN Pin as closely as possible. To maintain input voltage steady and filter out the pulsing input current.
3. The resistive divider R2and R4 must be connected to FB pin directly as closely as possible.
4. FB is a sensitive node. Please keep it away from switching node, SW. A good approach is to route the feedback trace on another layer and to have a ground plane between the top layer and the layer on which the feedback trace is routed. This reduces EMI radiation on to the DC-DC converter's own voltage feedback trace.

This datasheet contains new product information. Feeling Technology reserves the rights to modify the product specification without notice. No liability is assumed as a result of the use of this product. No rights under any patent accompany the sales of the product.

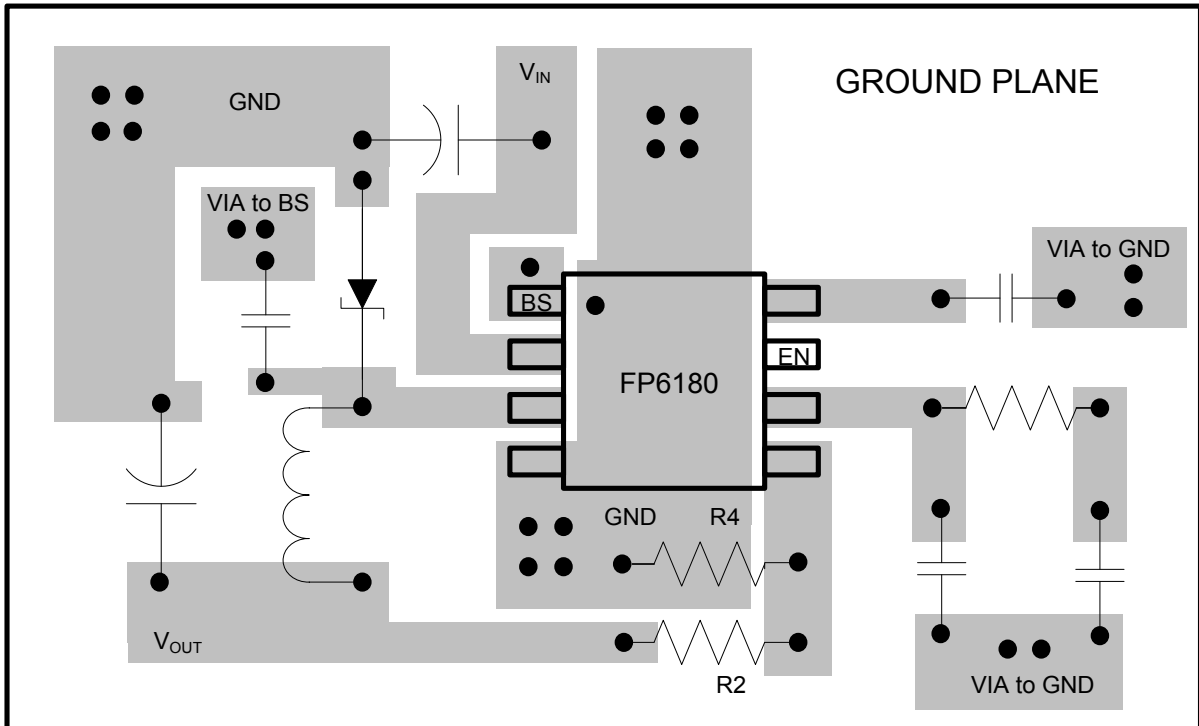

Suggested Layout

Typical Application

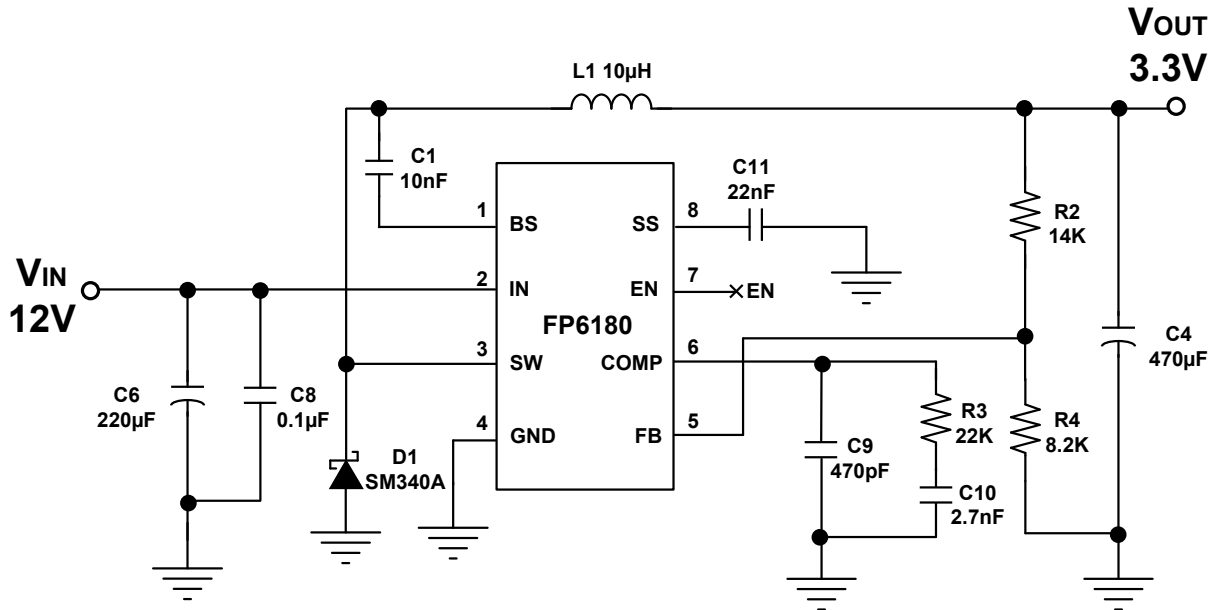

This datasheet contains new product information. Feeling Technology reserves the rights to modify the product specification without notice. No liability is assumed as a result of the use of this product. No rights under any patent accompany the sales of the product.

Package Outline

SOP-8L (EP)

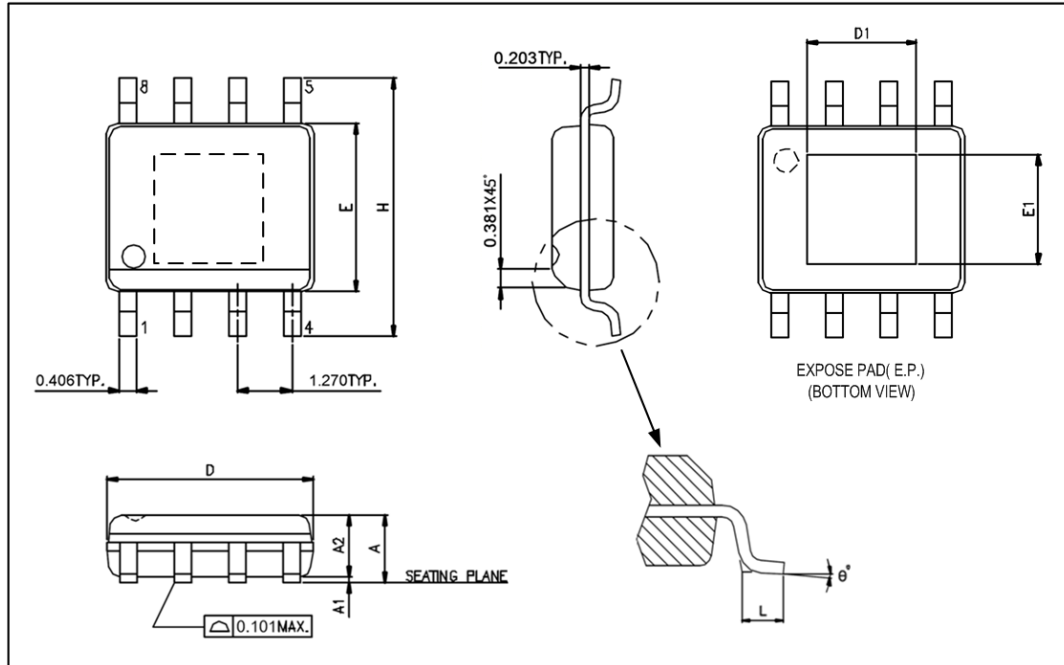

Unit: mm

Symbols	Min. (mm)	Max. (mm)
A	1.346	1.752
A1	0.050	0.152
A2		1.498
D	4.800	4.978
E	3.810	3.987
H	5.791	6.197
L	0.406	1.270
θ°	0°	8°

Exposed PAD Dimensions:

Symbols	Min. (mm)	Max. (mm)
E1		2.184 REF
D1		2.971 REF

Note:

1. Package dimensions are in compliance with JEDEC outline: MS-012 AA.
2. Dimension "D" does not include molding flash, protrusions or gate burrs.
3. Dimension "E" does not include inter-lead flash or protrusions.

This datasheet contains new product information. Feeling Technology reserves the rights to modify the product specification without notice. No liability is assumed as a result of the use of this product. No rights under any patent accompany the sales of the product.