

2A, 23V, 380KHz Step-Down Converter



General Description

The FP6187 is a buck regulator with a built-in internal power MOSFET. It can provide 2A continuous output current over a wide input supply range with excellent load and line regulation. Current mode operation provides fast transient response and eases loop stabilization. The device includes cycle-by-cycle current limiting and thermal shutdown protection. The regulator only consumes 23 μ A supply current in shutdown mode. The FP6187 requires a minimum number of readily available external components to complete a 2A buck regulator solution.

Features

- 2A Output Current
- 0.22 Ω Internal Power MOSFET Switch
- Stable with Low ESR Output Ceramic Capacitors Up to 95% Efficiency
- 23 μ A Shutdown Mode Current
- Fixed 380KHz frequency
- Thermal Shutdown
- Cycle-by-Cycle Over Current Protection
- Wide 4.75 to 23V Operating Input Range
- Output Adjustable From 1.23 to 21V
- Available SOP-8L Package
- Under Voltage Lockout

Applications

- Distributed Power Systems
- Battery Charger Network Cards
- Pre-Regulator for Linear Regulators
- DSL Modems

Typical Application Circuit

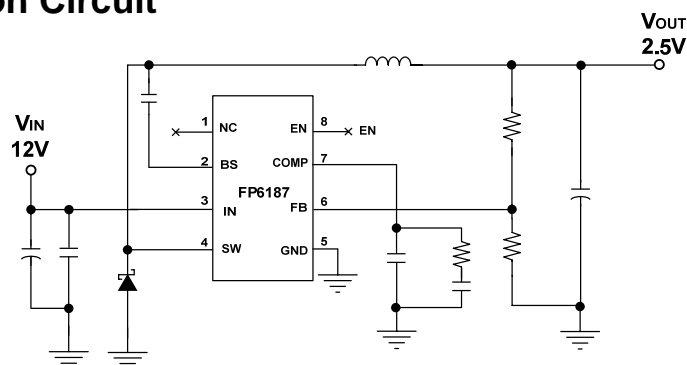

This datasheet contains new product information. Feeling Technology reserves the rights to modify the product specification without notice. No liability is assumed as a result of the use of this product. No rights under any patent accompany the sales of the product.

Function Block Diagram

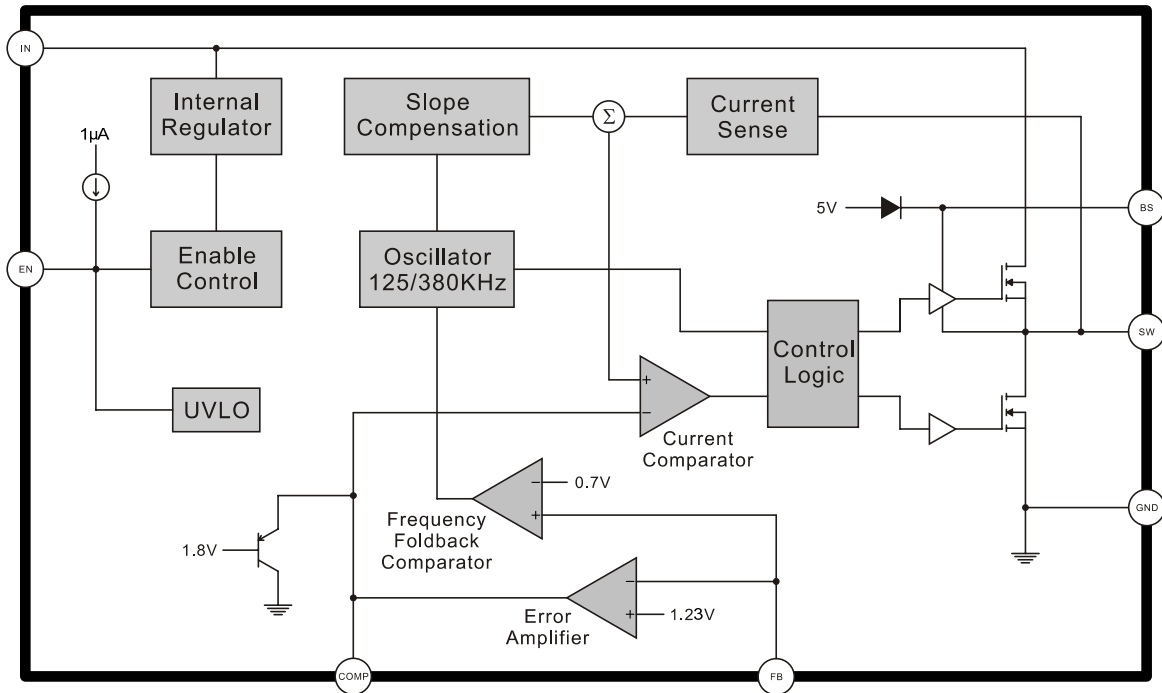

Pin Descriptions

SOP-8L

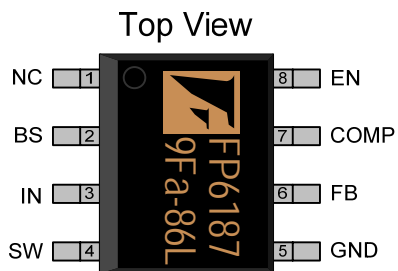

Name	No.	I / O	Description
NC	1		No Internal Connection
BS	2	O	Bootstrap
IN	3	P	Supply Voltage
SW	4	O	Switch
GND	5	P	Ground
FB	6	I	Feedback
COMP	7	O	Compensation
EN	8	I	EN / UVLO

This datasheet contains new product information. Feeling Technology reserves the rights to modify the product specification without notice. No liability is assumed as a result of the use of this product. No rights under any patent accompany the sales of the product.

IC Date Code Identification

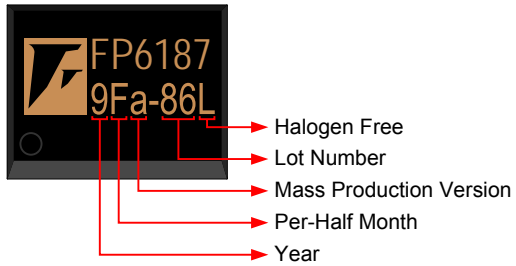

Halogen Free: Halogen free product indicator

Lot Number: Wafer lot number's last two digits

For Example: 132371TB → 71

Mass Production Version: Mass production mask version

Per-Half Month: Production period indicated in half month time unit

For Example: January → A (Front Half Month), B (Last Half Month)

February → C (Front Half Month), D (Last Half Month)

Year: Production year's last digit

Ordering Information

Part Number	Operating Temperature	Package	MOQ	Description
FP6187D-G1	-40°C ~ +85°C	SOP-8L	100EA	Tube
FP6187DR-G1	-40°C ~ +85°C	SOP-8L	2500EA	Tape & Reel

Absolute Maximum Ratings

Parameter	Symbol	Conditions	Min.	Typ.	Max.	Unit
Supply Voltage	V_{IN}		-0.3		24	V
Supply Voltage	V_{sw}		-1		$V_{IN} + 0.3$	V
Bootstrap Voltage	V_{BS}		$V_{sw} - 0.3$		$V_{sw} + 6$	V
All Other Pins			-0.3		6	V
Junction Temperature	T_J				+150	°C
Storage Temperature	T_S		-65		+150	°C
Allowable Power Dissipation		SOP-8L			570	mW
Thermal Resistance	θ_{JA}	SOP-8L		+110		°C / W
	θ_{JC}				+55	°C / W
Lead Temperature (soldering, 10 sec)		SOP 8L		+260		°C

Suggested IR Re-flow Soldering Curve

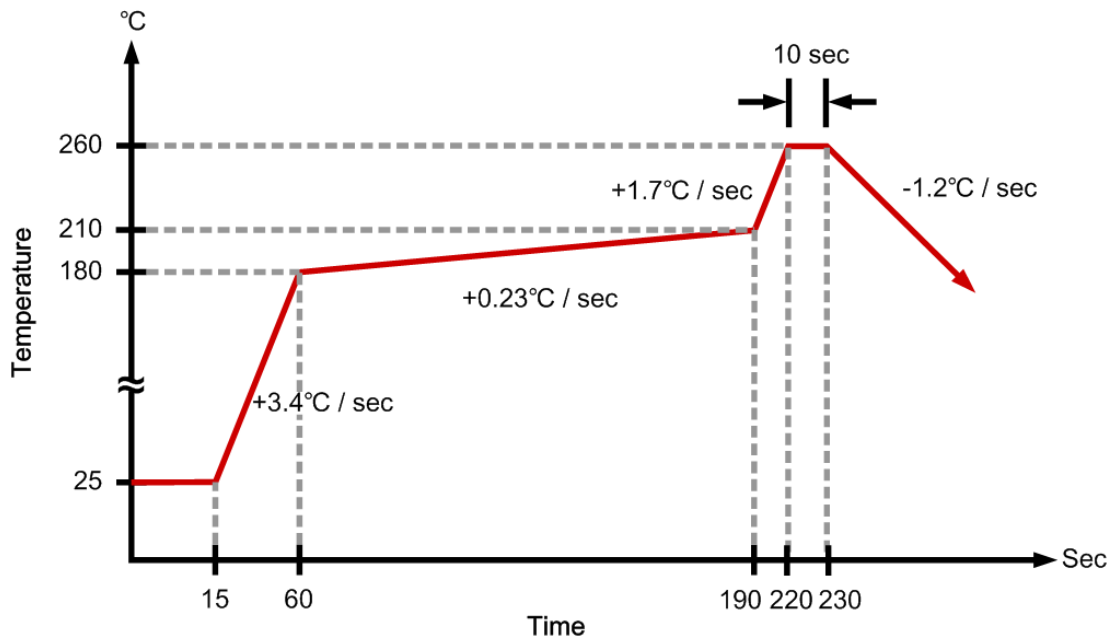

This datasheet contains new product information. Feeling Technology reserves the rights to modify the product specification without notice. No liability is assumed as a result of the use of this product. No rights under any patent accompany the sales of the product.

Recommended Operating Conditions

Parameter	Symbol	Conditions	Min.	Typ.	Max.	Unit
Supply Voltage	V_{IN}		4.75		23	V
Operating Temperature			-40		85	°C

DC Electrical Characteristics ($V_{IN}=12V$, $T_A=25^{\circ}C$, unless otherwise noted)

Parameter	Symbol	Test Conditions	Min.	Typ.	Max.	Unit
Standby Current	I_{SB}	$V_{EN} \geq 3V$, $V_{FB} \geq 1.5V$		1.0	1.5	mA
Shutdown Supply Current	I_{ST}	$V_{EN}=0V$		23	50	μA
Feedback Voltage	V_{FB}	$V_{COMP} < 2V$	1.17	1.23	1.27	V
High Side Switch ON Resistance	R_{ON-HS}			0.22		Ω
Low Side Switch ON Resistance	R_{ON-LS}			10		Ω
High Side Switch Leakage Current	I_{IL}	$V_{EN}=0V$, $V_{SW}=0V$		0.1	10	μA
Current Limit	I_{CL}		2.8	3.4	4.7	A
Oscillation Frequency	f_{OSC}		320	380	460	KHz
Short Circuit Oscillation Frequency	f_{SC}	$V_{FB}=0V$		125		KHz
Maximum Duty Cycle	D_{MAX}	$V_{FB}=1.0V$		90		%
Minimum Duty Cycle	D_{MIN}	$V_{FB}=1.5V$			0	%
Under Voltage Lockout Threshold	V_{UVLO}	V_{EN} Rising	2.0	2.5	3.0	V
Under Voltage Lockout Threshold Hysteresis	V_{HYS}			200		mV
EN Threshold Voltage	V_{EN}	$I_{CC} > 100\mu A$	0.7	1.0	1.3	V
EN Pull Up Current	I_{EN}	$V_{EN}=0V$		1.0		μA
Thermal Shutdown	T_{TS}			+140		°C

This datasheet contains new product information. Feeling Technology reserves the rights to modify the product specification without notice. No liability is assumed as a result of the use of this product. No rights under any patent accompany the sales of the product.

Typical Operating characteristics

($V_{IN}=12V$, $T_A=25^{\circ}C$, $V_{OUT}=3.3V$ unless otherwise noted)

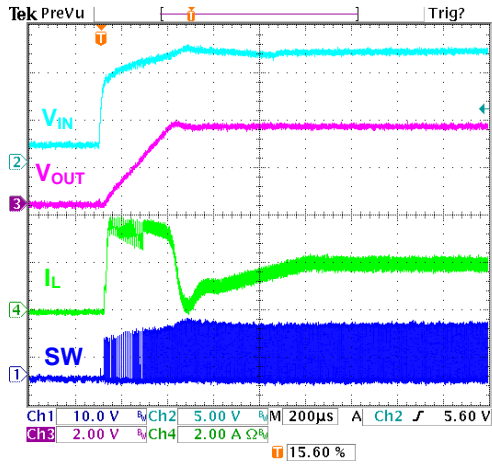

Figure 1 Power on

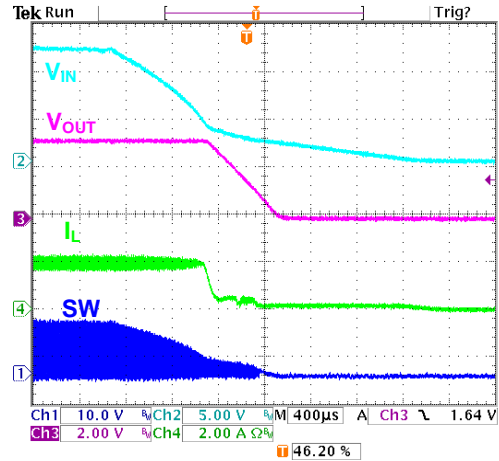

Figure 2 Power off

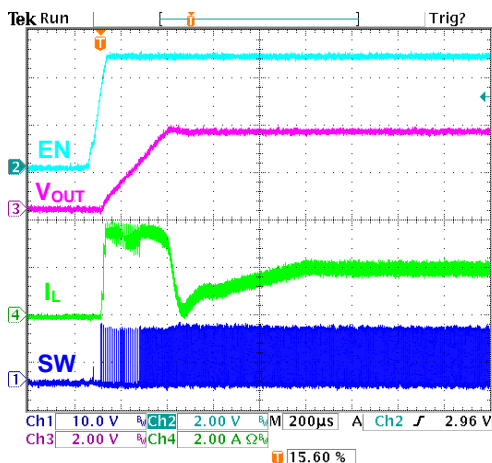

Figure 3 EN pin Enable

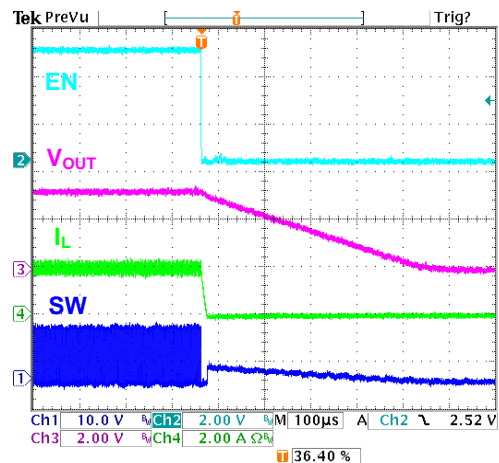

Figure 4 EN pin Disable

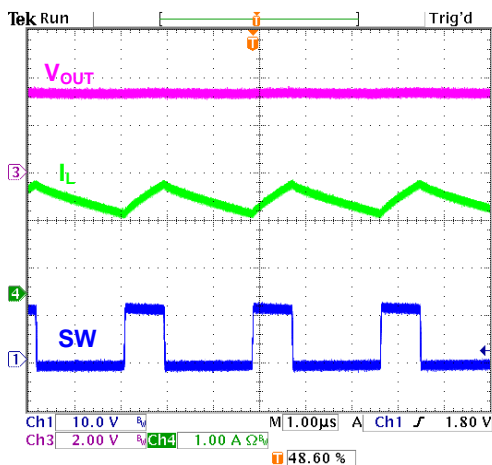

Figure 5 Load 3A

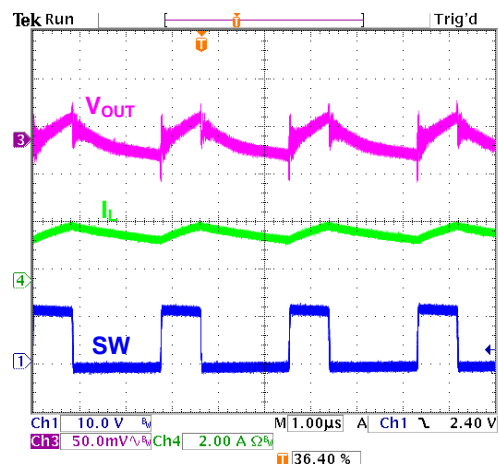

Figure 6 Load Ripple

This datasheet contains new product information. Feeling Technology reserves the rights to modify the product specification without notice. No liability is assumed as a result of the use of this product. No rights under any patent accompany the sales of the product.

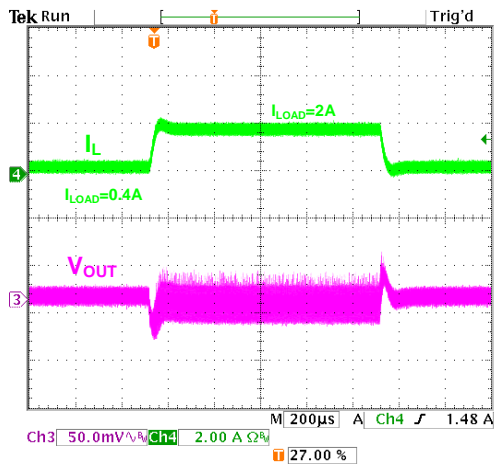

Figure 7 Load Step

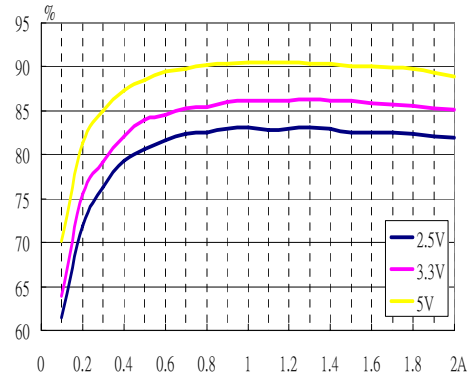

Figure 8 Efficiency ($V_{IN}=10V$)

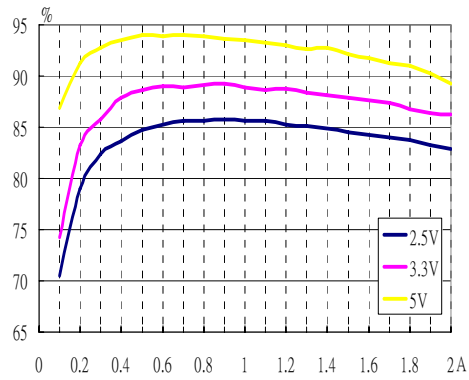

Figure 9 Efficiency ($V_{IN}=7V$)

Function Description

The FP6187 is a current-mode buck regulator. It regulates input voltages from 4.75V to 23V down to an output voltage as low as 1.23V with maximum 2A load current. The FP6187 uses current-mode control to regulate the output voltage. The output voltage is measured at FB pin through a resistive voltage divider and amplified by the internal error amplifier. The output current of the trans-conductance error amplifier is presented at COMP pin where a network compensates the regulation control system. The voltage at COMP pin is compared to the switch current measured internally to control the output voltage. The converter uses an internal n-channel MOSFET switch to step-down the input voltage to the regulated output voltage. Since the MOSFET requires a gate voltage greater than the input voltage, a boost capacitor connected between SW and BS drives the gate. The capacitor is internally charged while the switch is off. Another internal built-in 10Ω switch from SW to GND is used to insure that SW is pulled to GND when the switch is off to fully charge the BS capacitor.

Output Voltage (V_{OUT})

The output voltage is set using a resistive voltage divider from the output voltage to FB. The voltage divider divides the output voltage down by the ratio:

$$V_{FB} = V_{OUT} \times \frac{R_4}{R_2 + R_4}$$

Thus the output voltage is:

$$V_{OUT} = V_{FB} \times \frac{R_2 + R_4}{R_4}$$

A typical value for R_4 can be as high as 100k, but a typical value is 10K.

Enable Mode / Shutdown Mode

Drive EN pin to ground to shut down the FP6187. Shutdown mode forces the internal power MOSFET off, turns off all internal circuitry, and reduces the V_{IN} supply current to 23μA (typ.). The EN Pin rising threshold is 1.0V (typ.). Before any operation begins, the voltage at EN pin must exceed 1.0V (typ.).

The EN pin input has 100mV hysteresis.

Boost High-Side Gate Drive (BST)

Since the MOSFET requires a gate voltage greater than the input voltage, user should connect a flying bootstrap capacitor between SW and BS to provide the gate-drive voltage to the high-side n-channel MOSFET switch. The capacitor is charged by the internally regulator periodically when SW pin is pulled to ground. During startup, an internal low-side switch pulls SW pin to ground and charges

This datasheet contains new product information. Feeling Technology reserves the rights to modify the product specification without notice. No liability is assumed as a result of the use of this product. No rights under any patent accompany the sales of the product.

the BST capacitor to internally regulator output voltage. Once the BST capacitor is charged, the internal low-side switch is turned off and the BST capacitor voltage provides the necessary enhancement voltage to turn on the high-side switch.

Thermal Shutdown Protection

The FP6187 features integrated thermal shutdown protection. Thermal shutdown protection limits allowable power dissipation (P_D) in the device, and protects the device in the event of a fault condition. When the IC junction temperature exceeds $+150^{\circ}\text{C}$, an internal thermal sensor signals the shutdown logic to turn off the internal power MOSFET and allow the IC cooling down. The thermal sensor turns the internal power MOSFET back on after the IC junction temperature cools down to $+110^{\circ}\text{C}$, resulting in a pulsed output under continuous thermal overload conditions.

Application Information

Input Capacitor Selection

The input current to the step-down converter is discontinuous, therefore a capacitor is required to supply the AC current to the step-down converter while maintaining the DC input voltage. Use low ESR capacitors for the best performance. Ceramic capacitors are preferred, but tantalum or low-ESR electrolytic capacitors may also suffice.

The input capacitor can be electrolytic, tantalum or ceramic. When electrolytic or tantalum capacitors are used, a small, high quality 0.1 μ F ceramic capacitor should be placed beside the IC as close as possible.

When using ceramic capacitors, make sure that they have enough capacitance to provide sufficient charge to prevent excessive voltage ripple at converter input. The input voltage ripple can be estimated by

$$C_{IN} = \frac{I_o}{f \times \Delta V_{IN}} \times D(1-D)$$

Inductor Selection

The inductor is required to supply current to the output load while being driven by the switched input voltage. A larger value inductor will result in less ripple current that will result in lower output ripple voltage. However, the larger value inductor will have a larger physical size, higher series resistance, and/or lower saturation current. A good rule for determining the inductance to use is to allow the peak-to-peak ripple current in the inductor to be approximately 30% of the maximum switch current limit. Also, make sure that the peak inductor current is below the maximum switch current limit. The inductance value can be calculated by

$$L = \frac{V_o + V_D}{I_o \gamma f} \times (1-D)$$

Where γ is the ripple current ratio

$$\text{RMS current in inductor } I_{L_{rms}} = I_o \sqrt{1 + \frac{\gamma^2}{12}}$$

Output Capacitor Selection

The output capacitor is required to maintain the DC output voltage. Ceramic, tantalum, or low ESR electrolytic capacitors are recommended. Low ESR capacitors are preferred to keep the output voltage ripple low. The output voltage ripple can be estimated by:

$$\Delta V_{OUT} = \frac{V_{OUT} \times (V_{IN} - V_{OUT})}{f \times L \times V_{IN}} \times \left(ESR + \frac{1}{8 \times f \times C_{OUT}} \right)$$

In the case of ceramic capacitors, the output ripple is dominated by the capacitance value because of its low ESR. In the case of tantalum or electrolytic capacitors, the capacitor high ESR dominates the output ripple. Followings are equations for determining appropriate capacitor parameters.

I . Ceramic capacitors: choose capacitance value

$$C_{OUT} = \frac{V_{OUT}}{8 \times f^2 \times L \times \Delta V_{OUT}} \times \left(1 - \frac{V_{OUT}}{V_{IN}} \right)$$

II . Tantalum or electrolytic capacitors: choose capacitor with ESR value

$$ESR = \frac{\Delta V_{OUT} \times f \times L \times V_{IN}}{V_{OUT} \times (V_{IN} - V_{OUT})}$$

PC Board Layout Checklist

1. The power traces, consisting of the GND, SW and V_{IN} traces, should be kept short, direct and wide.
2. Place C_{IN} near IN pin as closely as possible to maintain input voltage steady and filter out the pulsing input current.
3. The resistive divider R_2 and R_4 must be connected to FB pin directly as closely as possible.
4. FB is a sensitive node. Please keep it away from switching node SW. A good approach is to route the feedback trace on another layer and have a ground plane between the top and feedback trace routing layer. This reduces EMI radiation on to the DC-DC converter's own voltage feedback trace.

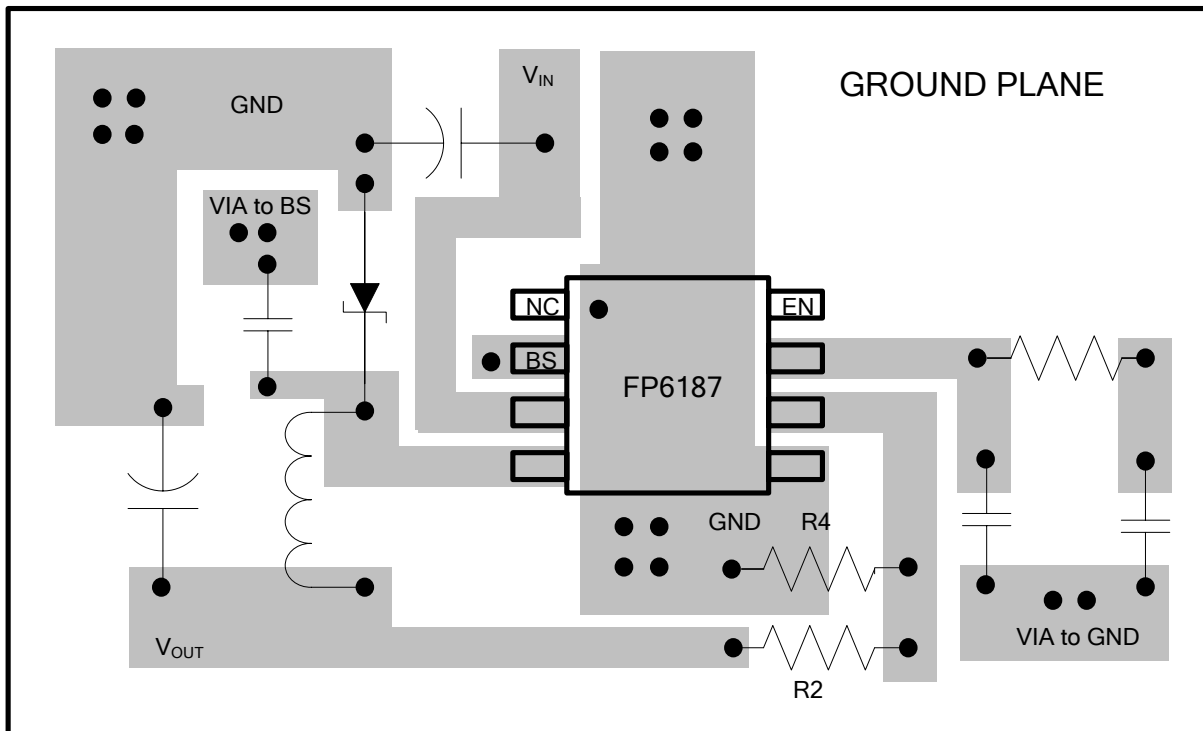

Suggested Layout

Typical Application

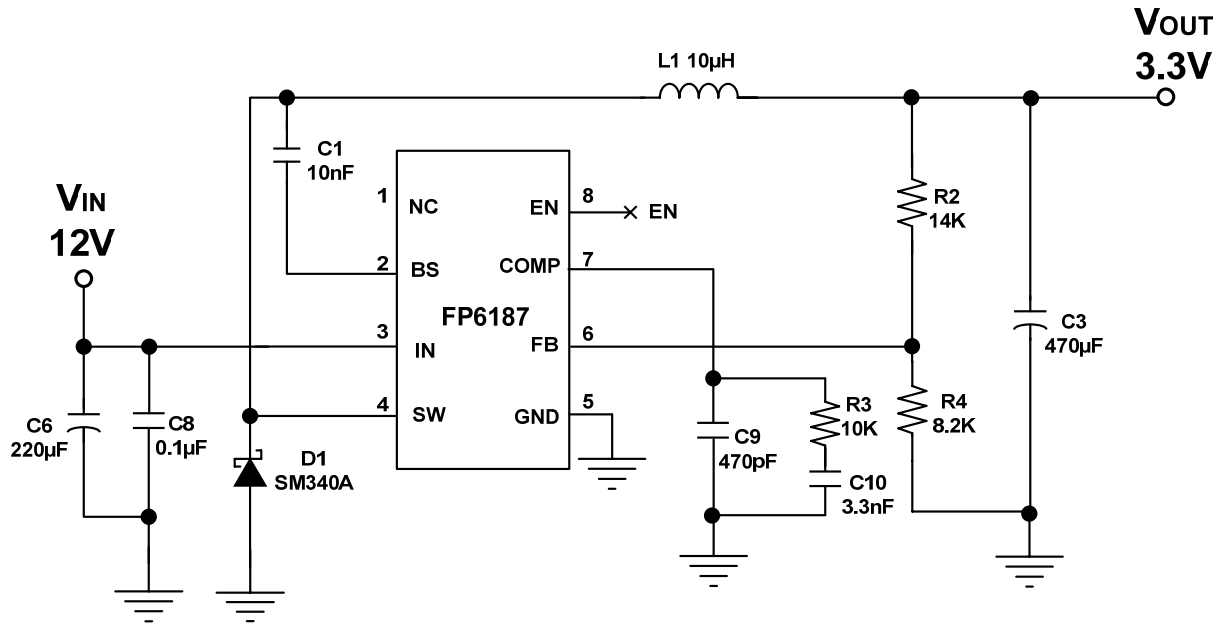

This datasheet contains new product information. Feeling Technology reserves the rights to modify the product specification without notice. No liability is assumed as a result of the use of this product. No rights under any patent accompany the sales of the product.

Package Outline

SOP-8L

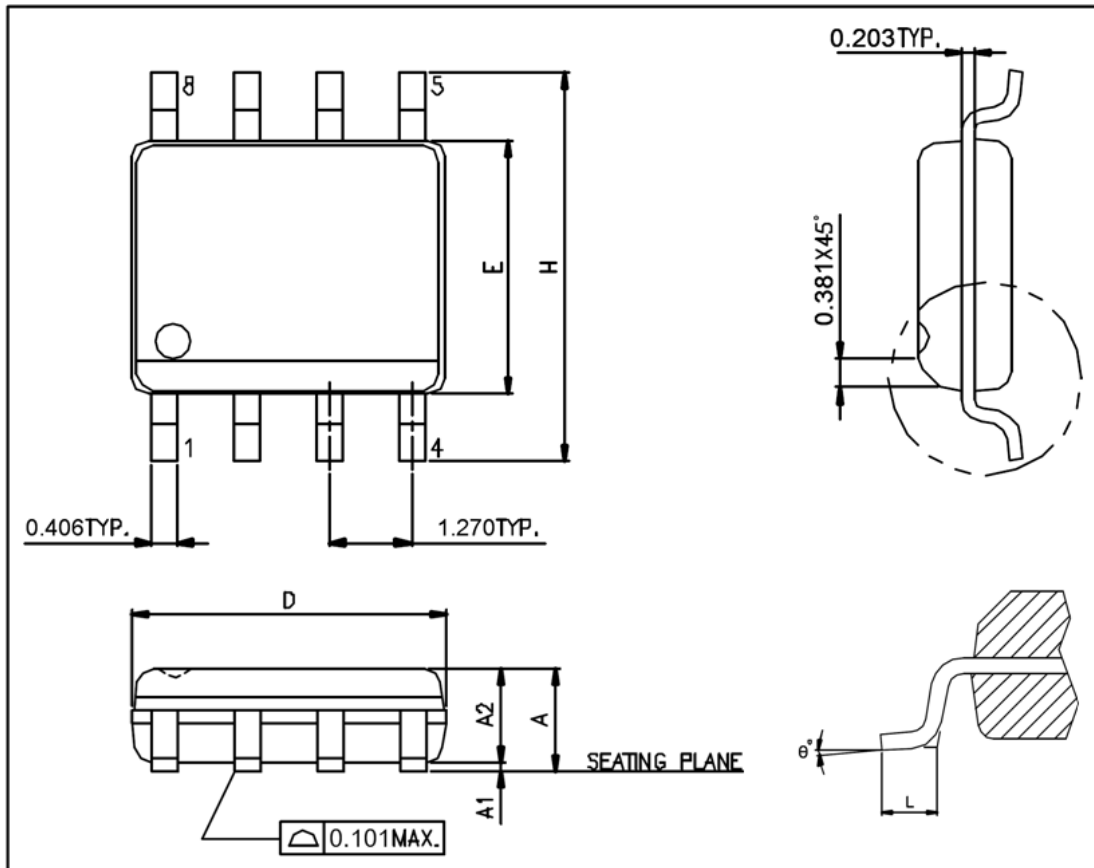

UNIT: mm

Symbols	Min. (mm)	Max. (mm)
A	1.346	1.752
A1	0.101	0.254
A2	1.092	1.498
D	4.800	4.978
E	3.810	3.987
H	5.791	6.197
L	0.406	1.270
θ°	0°	8°

Note:

1. Package dimensions are in compliance with JEDEC outline: MS-012 AA.
2. Dimension "D" does not include molding flash, protrusions or gate burrs.
3. Dimension "E" does not include inter-lead flash or protrusions.

This datasheet contains new product information. Feeling Technology reserves the rights to modify the product specification without notice. No liability is assumed as a result of the use of this product. No rights under any patent accompany the sales of the product.