

60V, 800mA, 480KHz Asynchronous Step-Down Converter



General Description

The FP6195 is a buck regulator with a built-in internal power MOSFET. It can provide 0.8A continuous output current over a wide input supply range with excellent load and line regulation. Current mode operation provides fast transient response and eases loop stabilization. This device includes cycle-by-cycle current limiting and thermal shutdown protection. Internal soft-start reduces the stress on the input source at power-on. The FP6195 requires a minimum number of readily available external components to complete a 0.8A buck regulator solution.

Features

- 0.8A Output Current
- 0.7Ω Internal High Side Power MOSFET Switch
- Stable with Low ESR Output Ceramic Capacitors
- Up to 91% Efficiency
- 1μA Shutdown Mode Current
- Fixed 480KHz Frequency
- Thermal Shutdown
- Cycle-by-Cycle Over Current Protection
- Wide 9V to 60V Operating Input Range
- Output Adjustable From 0.812V to 0.9*V_{IN}
- Max Duty 90%
- Available in SOT23-6L Packages

Applications

- Distributed Power Systems
- Battery Charger
- Pre-Regulator for Linear Regulators
- Power Meters

Typical Application Circuit

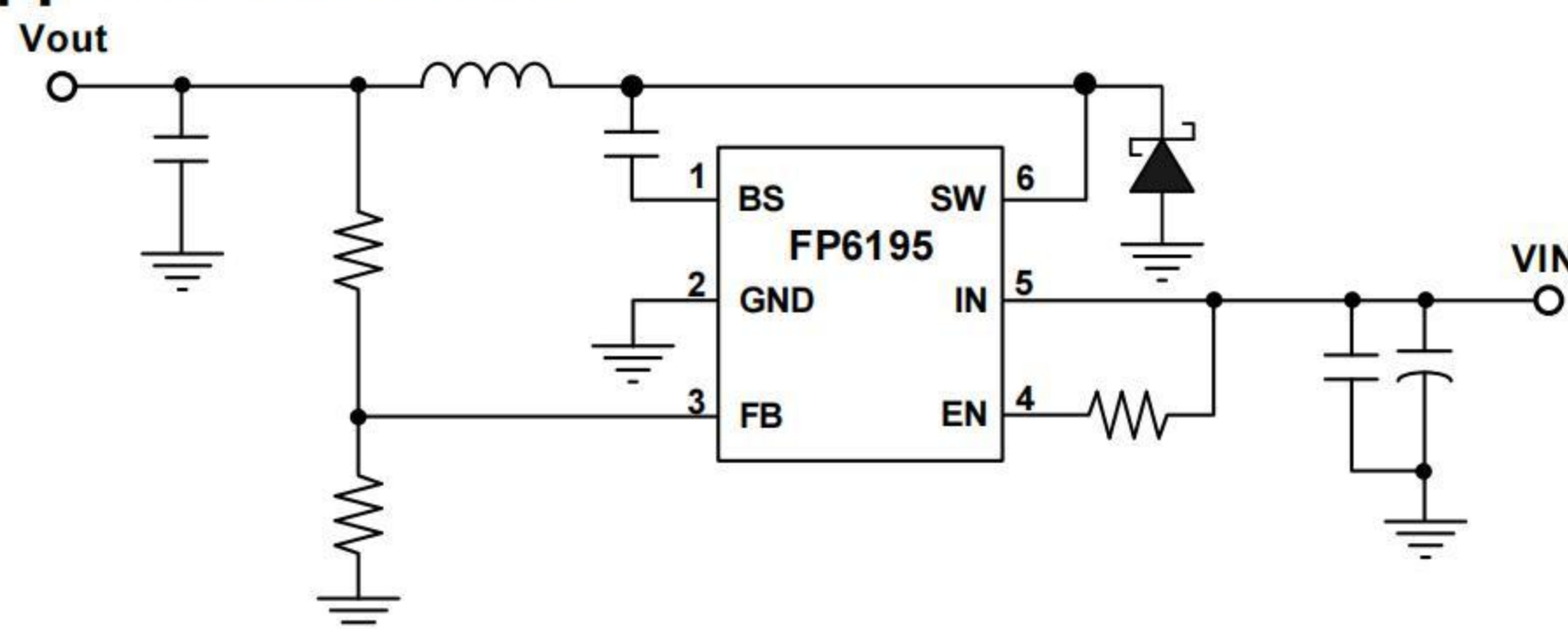

This datasheet contains new product information. Advanced Analog Technology reserves the rights to modify the product specification without notice. No liability is assumed as a result of the use of this product. No rights under any patent accompany the sales of the product.

Rev. 0.60

Function Block Diagram

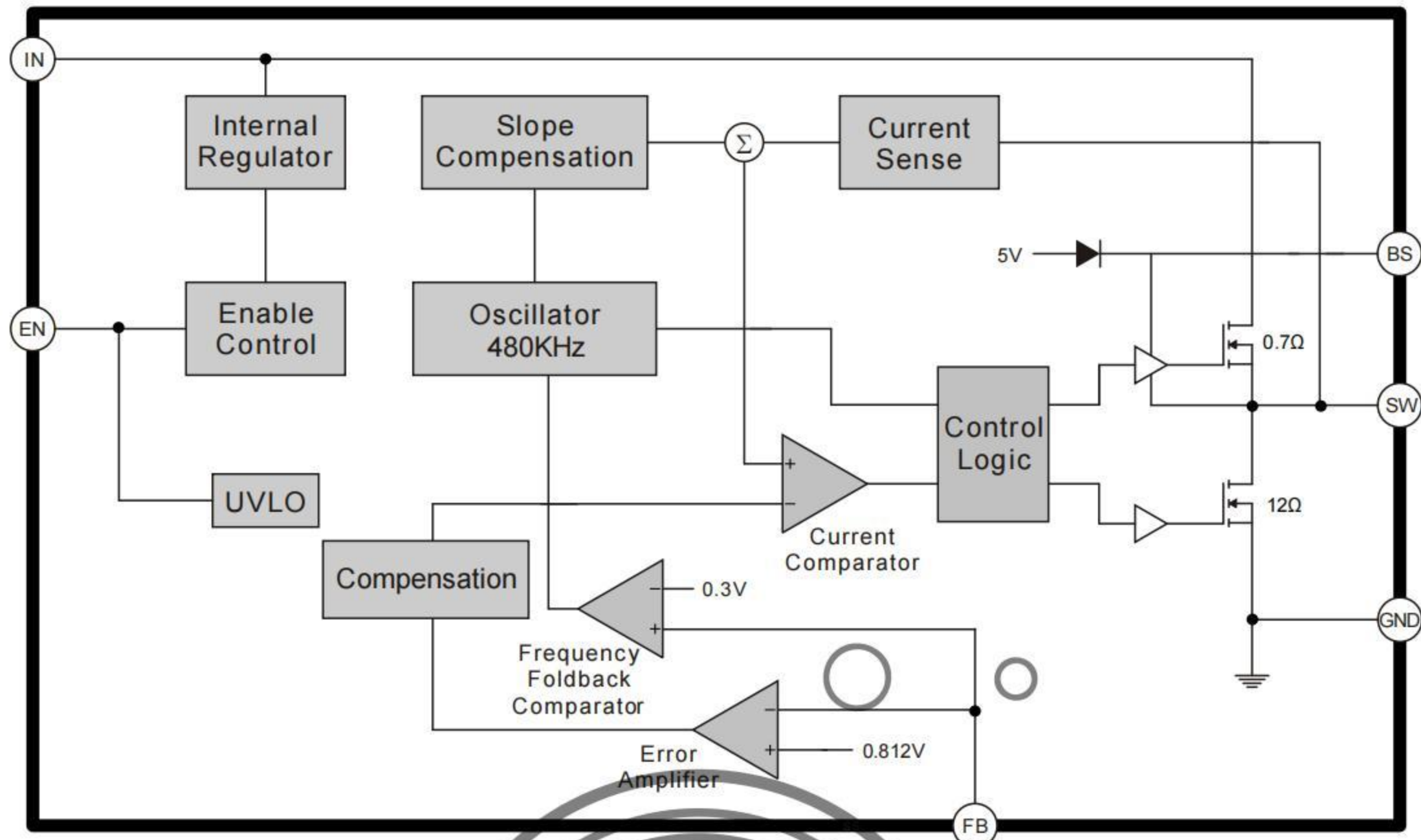

一级代理: 李生 13691661579

Pin Descriptions

SOT23-6L

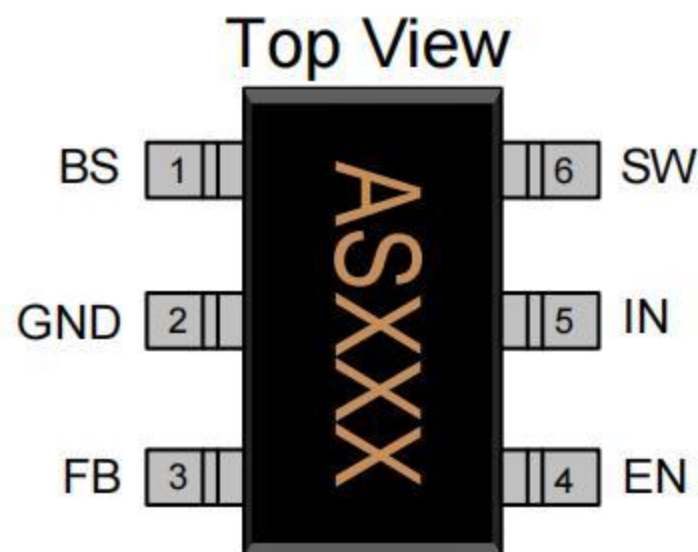

Name	No.	I / O	Description
BS	1	P	Bootstrap
GND	2	P	IC Ground
FB	3	I	Feedback. Sets the output voltage
EN	4	I	Enable Control (For automatic enable, connect to V_{IN} using a 1M Ω resistor.)
IN	5	P	Supply Voltage
SW	6	O	Switch

Marking Information

SOT23-6L

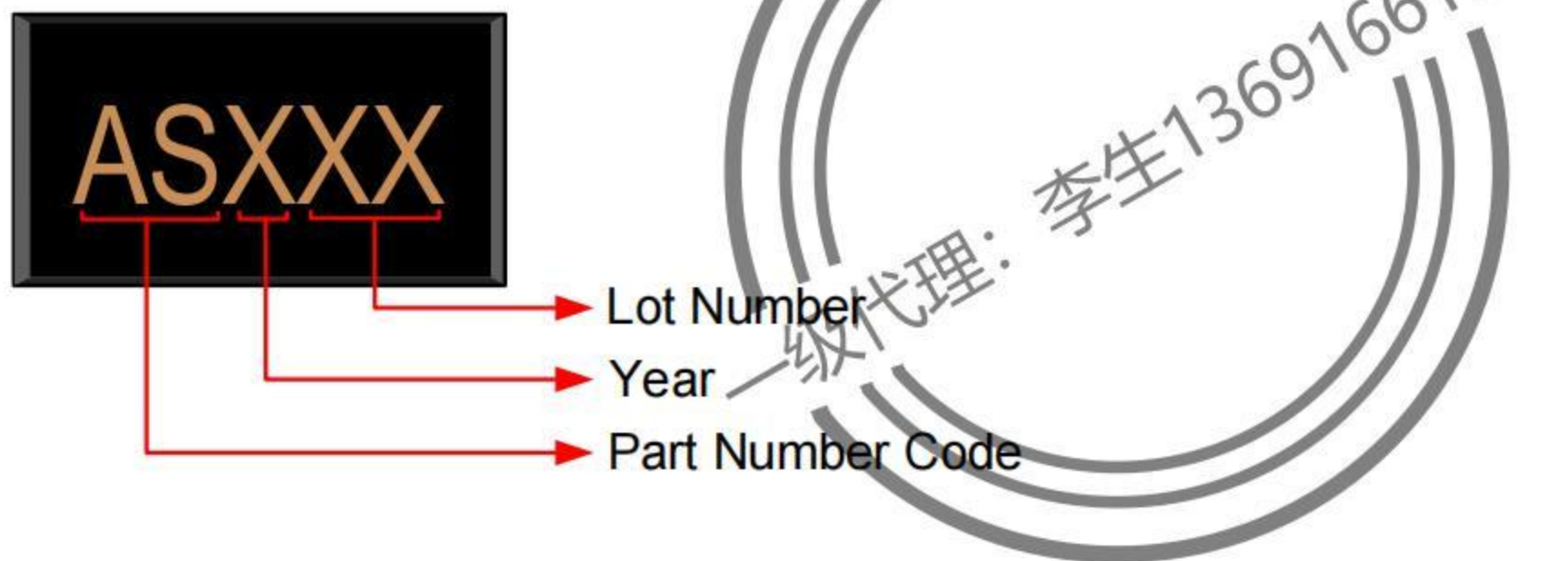

Lot Number: Wafer lot number's code

Year: Production year's last digit

Part Number Code: Part number identification code for this product. It should be always "AS"

Ordering Information

Part Number	Operating Junction Temperature	Package	MOQ	Description
FP6195LR-G1	-40°C ~ +85°C	SOT23-6L	3000EA	Tape & Reel

Absolute Maximum Ratings

Parameter	Symbol	Conditions	Min.	Typ.	Max.	Unit
Supply Voltage	V_{IN}		-0.3		65	V
Switch Voltage	V_{sw}		-0.3		$V_{IN} + 0.3$	V
Bootstrap Voltage	V_{BS}		$V_{sw} - 0.3$		$V_{sw} + 6$	V
All Other Pins			-0.3		6	V
Operating Temperature			-40		+85	°C
Storage Temperature			-55		+150	°C
Junction Temperature	T_J				+150	°C
Allowable Power Dissipation	P_D	$T_A = 25^\circ\text{C}$			455	mW
Junction to Ambient Thermal Resistance	θ_{JA}				+220	°C / W
Junction to Case Thermal Resistance	θ_{JC}				+130	°C / W
Lead Temperature (soldering, 10 sec)					+260	°C

IR Re-flow Soldering Curve

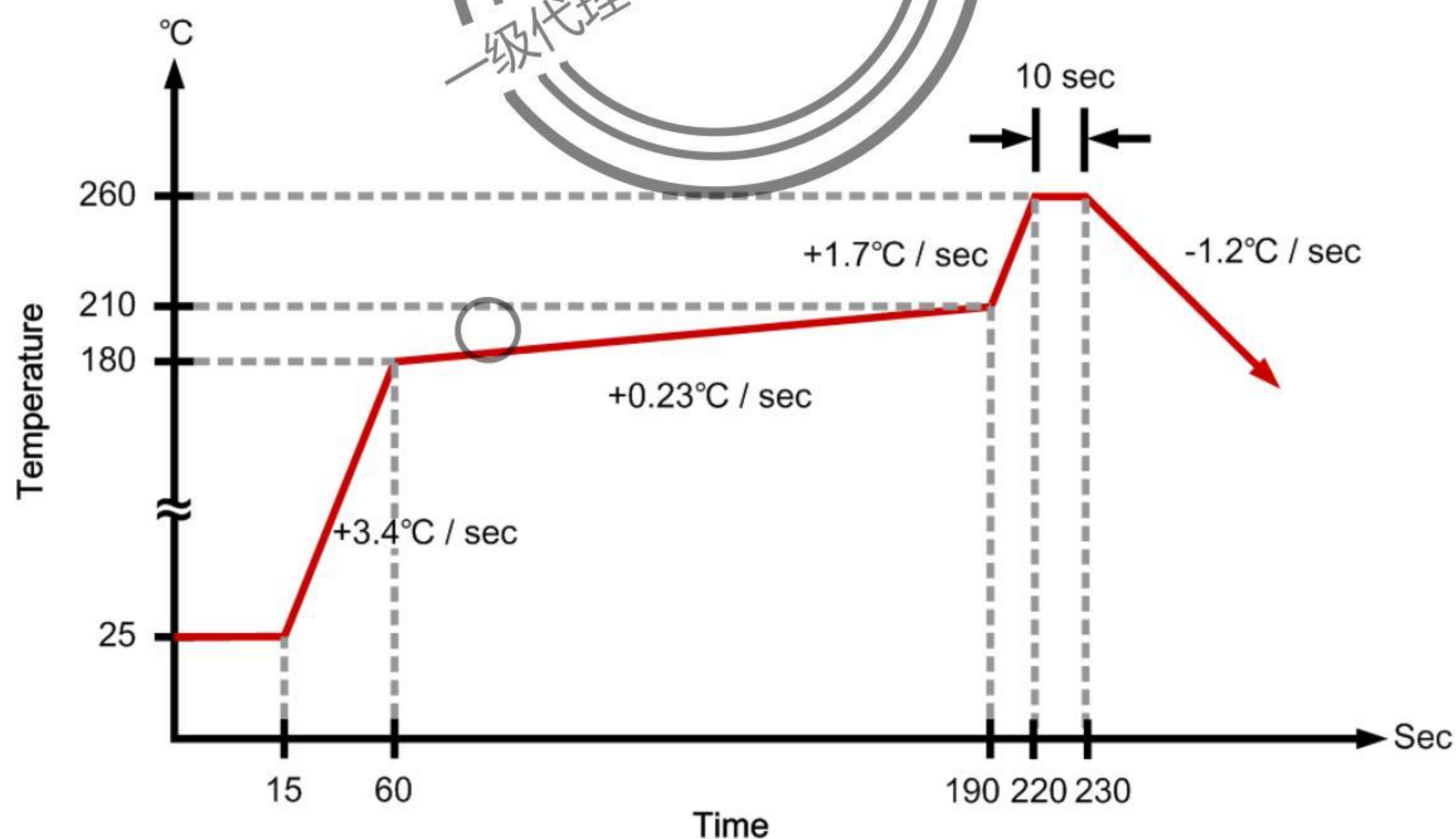

Recommended Operating Conditions

Parameter	Symbol	Conditions	Min.	Typ.	Max.	Unit
Supply Voltage	V_{IN}		9		60	V
Operating Junction Temperature			-40		85	°C

DC Electrical Characteristics ($V_{IN}=12V$, $T_A=25^{\circ}C$, unless otherwise noted)

Parameter	Symbol	Test Conditions	Min.	Typ.	Max.	Unit
Standby Current	I_{SB}	$V_{EN}=2V$, $V_{FB}=1.0V$		4.5		mA
Shutdown Supply Current	I_{ST}	$V_{EN}=0$			1	μA
Feedback Voltage	V_{FB}	$4.5V < V_{IN} < 24V$		0.812		V
Feedback Current	I_{FB}	$V_{FB}=0.85V$		0.1		μA
Switch ON Resistance	R_{ON}			0.7		Ω
Switch Leakage Current	I_{IL}	$V_{EN}=0$, $V_{SW}=0V$			1	μA
Current Limit	I_{CL}			1.6		A
Oscillation Frequency	f_{OSC}			480		KHz
Short Circuit Oscillation Frequency	f_{SC}	$V_{FB}=0V$		60		KHz
Maximum Duty Cycle	D_{MAX}	$V_{FB}=0.6V$		90		%
Minimum On Time	T_{ON}			100		ns
Under Voltage Lockout Threshold	V_{UVLO_R}	V_{IN} Rising		7.5		V
	V_{UVLO_F}	V_{IN} Falling		7		V
Under Voltage Lockout Threshold Hysteresis	V_{HYS}			500		mV
EN Threshold, Rising	V_{EN_R}			1.57		V
EN Threshold, Falling	V_{EN_F}			1.37		V
EN Threshold, Hysteresis	V_{EN_HYS}			200		mV
EN Input Current	I_{EN}	$V_{EN}=2V$		3.1		μA
		$V_{EN}=0V$		0.1		
Thermal Shutdown	T_{TS}			160		°C
Thermal Shutdown Hysteresis	T_{SD_HYS}			40		°C

Function Description

The FP6195 is a current-mode step-down DC / DC converter that provides excellent transient response with no extra external compensation components. It regulates input voltages from 9V to 60V down to an output voltage as low as 0.812V with maximum 0.8A load current. and operates at a high operating frequency to ensure a compact, high-efficiency design with excellent AC and DC performance. The output voltage is measured at FB pin through a resistive voltage divider and amplified by the internal error amplifier. The converter uses an internal n-channel MOSFET switch to step-down the input voltage to the regulated output voltage. Since the n-channel MOSFET requires a gate voltage greater than the input voltage, a boost capacitor connected between SW and BS drives the MOS gate. The capacitor is internally charged while the MOS switch is off.

Output Voltage (V_{OUT})

The output voltage is set using a resistive voltage divider from the output voltage to FB. The voltage divider divides the output voltage down by the ratio:

$$V_{FB} = V_{OUT} \times \frac{R_2}{R_1 + R_2}$$

Thus the output voltage is:

$$V_{OUT} = V_{FB} \times \frac{R_1 + R_2}{R_2}$$

Enable Mode / Shutdown Mode

Drive the EN Pin to ground to shutdown the FP6195. Shutdown forces the internal power MOSFETs off, turns off all internal circuitry. The EN Pin rising threshold is 1.57V (typ), and hysteresis is 200mV. For automatic startup application, pull up the EN pin with 1M Ω resistor.

Boost High-Side Gate Drive (BST)

Since the MOSFET requires a gate voltage greater than the input voltage, user should connect a flying bootstrap capacitor between SW and BS pin to provide the gate-drive voltage to the high-side n-channel MOSFET switch. The capacitor is charged by the internally regulator periodically when SW pin is pulled to ground. During startup, an internal low-side switch pulls SW to ground and charges the BST capacitor to internally regulator output voltage. Once the BST capacitor is charged, the internal low-side switch is turned off and the BST capacitor provides the necessary enhancement voltage to turn on the high-side switch.

Over Current Protection

Over-current limiting is implemented by sensing the drain-to-source voltage across the high-side MOSFET. The drain to source voltage is then compared to a voltage level representing the over-current threshold limit. If the drain-to-source voltage exceeds the over-current threshold limit, the over-current indicator is set true. Once over-current indicator is set true, over-current limiting is triggered. The high-side MOSFET is turned off for the rest of the cycle. The output voltage will start to drop if the output is dead-short to ground, suddenly. Once the FB is lower than 0.3V, the switching frequency of FP6195 is folded back to around $1/8 F_{osc}$.

Thermal Shutdown Protection

The FP6195 features integrated thermal shutdown protection. Thermal shutdown protection limits allowable power dissipation (P_D) in the device and protects the device in the event of a fault condition. When the IC junction temperature exceeds $+160^{\circ}\text{C}$, an internal thermal sensor signals the shutdown logic to turn off the internal power MOSFET and allow the IC cooling down. The thermal sensor turns in a pulsed output under continuous thermal overload conditions.

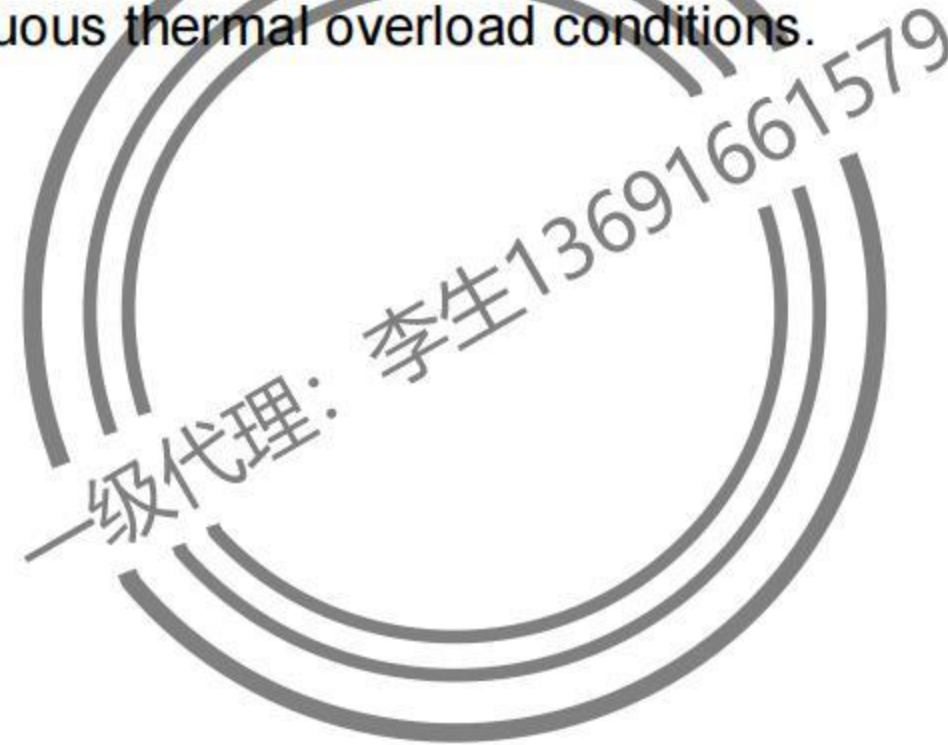

Application Information

Input Capacitor Selection

The input current to the step-down converter is discontinuous, therefore a capacitor is required to supply the AC current to the step-down converter while maintaining the DC input voltage. Use low ESR capacitors for the best performance. Ceramic capacitors are preferred, but tantalum or low-ESR electrolytic capacitors may also suffice.

The input capacitor can be electrolytic, tantalum or ceramic. When electrolytic or tantalum capacitors are used, a small, high quality 0.1µF ceramic capacitor should be placed beside the IC as possible.

When using ceramic capacitors, make sure that they have enough capacitance to provide sufficient charge to prevent excessive voltage ripple at converter input. The input voltage ripple can be estimated by

$$C_{IN} = \frac{I_O}{f \times \Delta V_{IN}} \times D(1 - D)$$

Inductor Selection

The inductor is required to supply constant current to the output load while being driven by the switched input voltage. A larger value inductor will result in less ripple current that will result in lower output ripple voltage. However, the larger value inductor will have a larger physical size, higher series resistance, and/or lower saturation current. A good rule for determining the inductance to use is to allow the peak-to-peak ripple current in the inductor to be approximately 30% of the maximum switch current. Also, make sure that the peak inductor current is below the maximum switch current limit. The inductance value can be calculated by

$$L = \frac{V_O + V_D}{I_O \gamma f} \times (1 - D)$$

Where r is the ripple current ratio

$$\text{RMS current in inductor } I_{L_{rms}} = I_O \sqrt{1 + \frac{\gamma^2}{12}}$$

Output Capacitor Selection

The output capacitor is required to maintain the DC output voltage. Ceramic, tantalum, or low ESR electrolytic capacitors are recommended. Low ESR capacitors are preferred to keep the output voltage ripple low. The output voltage ripple can be estimated by:

$$\Delta V_{OUT} = \frac{V_{OUT} \times (V_{IN} - V_{OUT})}{f \times L \times V_{IN}} \times \left(\text{ESR} + \frac{1}{8 \times f \times C_{OUT}} \right)$$

In the case of ceramic capacitors, the output ripple is dominated by the capacitance value because of its low ESR. In the case of tantalum or electrolytic capacitors, the capacitor high ESR dominates the output ripple. Followings are equations for determining appropriate capacitor parameters.

I . Ceramic capacitors: choose capacitance value

$$C_{OUT} = \frac{V_{OUT}}{8 \times f^2 \times L \times \Delta V_{OUT}} \times \left(1 - \frac{V_{OUT}}{V_{IN}} \right)$$

II . Tantalum or electrolytic capacitors: choose capacitor with ESR value

$$ESR = \frac{\Delta V_{OUT} \times f \times L \times V_{IN}}{V_{OUT} \times (V_{IN} - V_{OUT})}$$



PCB Layout Checklist

1. The power traces, consisting of the GND, SW and V_{IN} traces, should be kept short, direct and wide.
2. Place C_{IN} near IN pin as closely as possible to maintain input voltage steady and filter out the pulsing input current.
3. The resistive divider R_1 and R_2 must be connected directly to FB pin as closely as possible.
4. FB is a sensitive node. Please keep it away from switching node SW. A good approach is to route the feedback trace on another layer and have a ground plane between the top and feedback trace routing layer. This reduces EMI radiation on to the DC-DC converter's own voltage feedback trace.

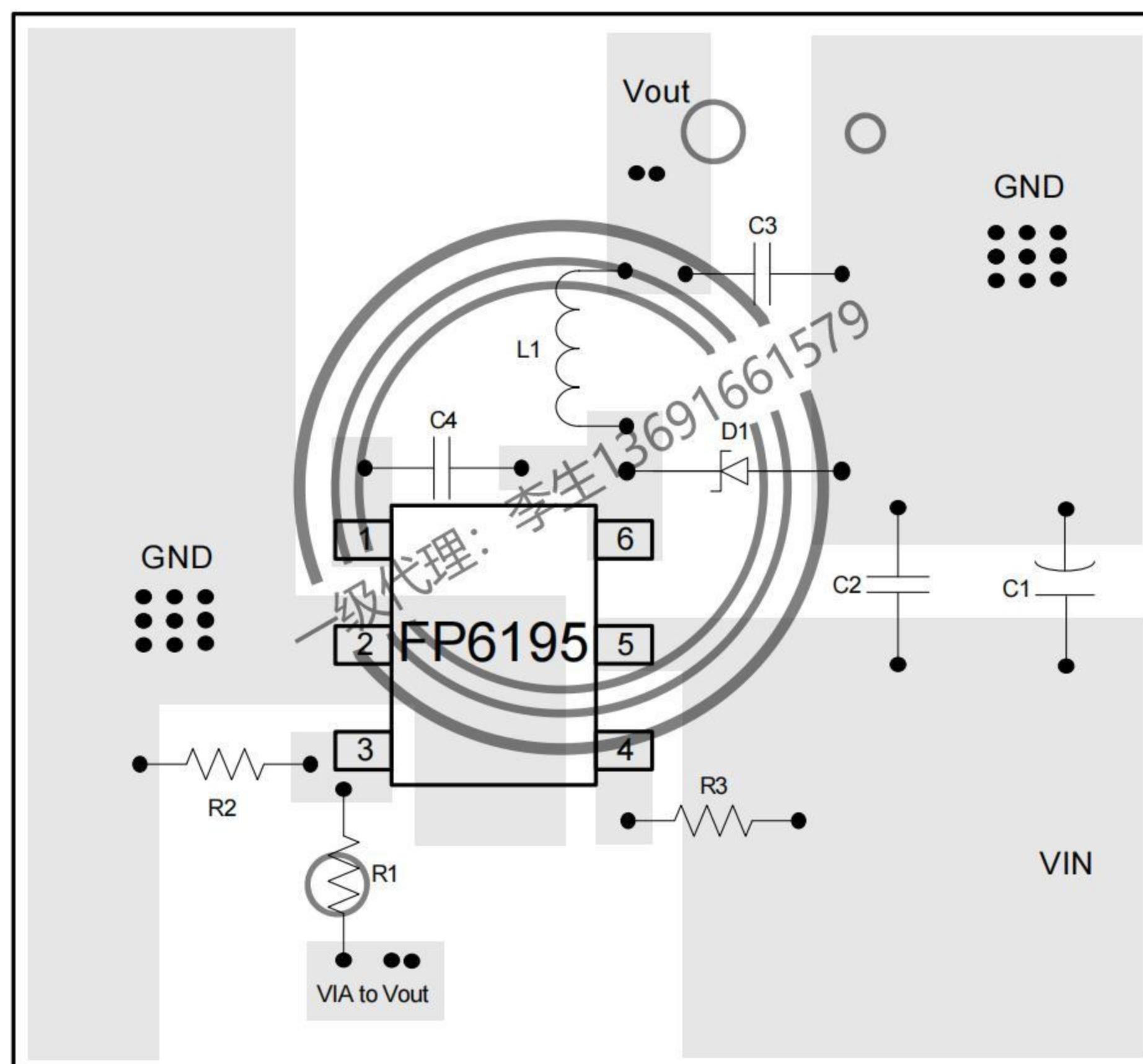

Typical Application

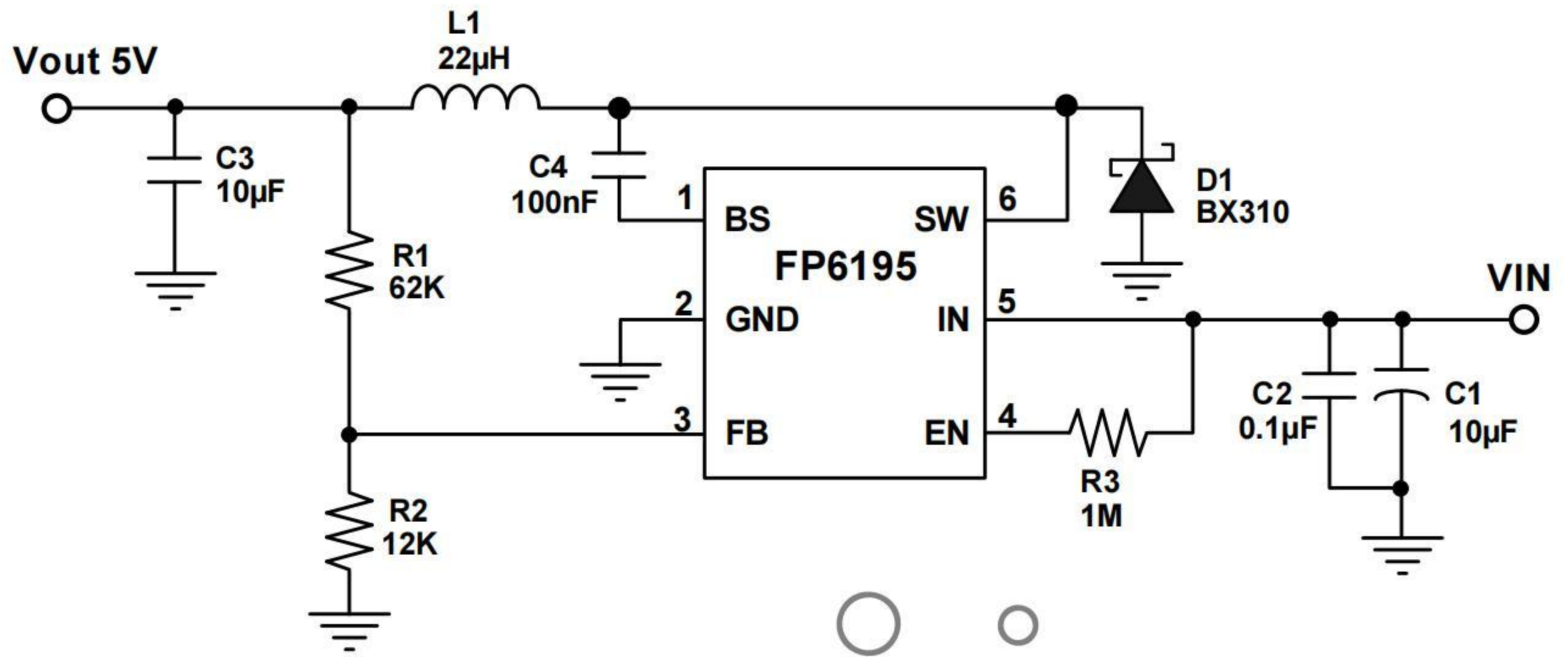

Package Outline

SOT23-6L

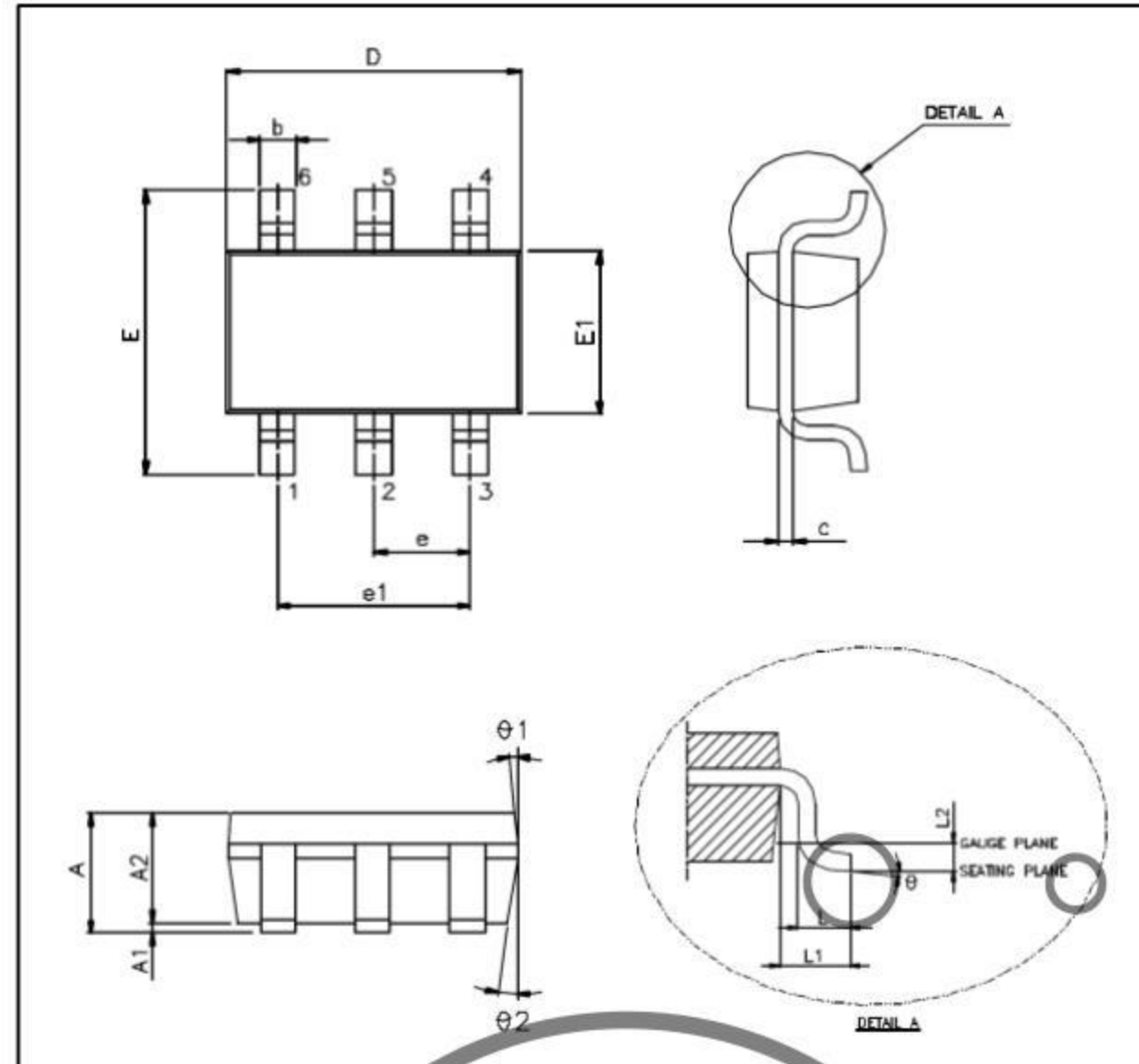

Unit: mm

Symbols	Min. (mm)	Max. (mm)
A	1.050	1.450
A1	0.050	0.150
A2	0.900	1.300
b	0.300	0.500
c	0.080	0.220
D	2.900 BSC	
E	2.800 BSC	
E1	1.600 BSC	
e	0.950 BSC	
e1	1.900 BSC	
L	0.300	0.600
L1	0.600 REF	
L2	0.250 BSC	
θ°	0°	8°
$\theta1^\circ$	3°	7°
$\theta2^\circ$	6°	15°

Note:

1. Package dimensions are in compliance with JEDEC outline: MO-178 AB.
2. Dimension "D" does not include molding flash, protrusions or gate burrs.
Dimension "E1" does not include inter-lead flash or protrusions.

This datasheet contains new product information. Advanced Analog Technology reserves the rights to modify the product specification without notice. No liability is assumed as a result of the use of this product. No rights under any patent accompany the sales of the product.