

## Dual USB Type-A HVDCP Controller With Plug In/Out Auto Detection

### Description

The FP6601AA is a dual ports USB Type-A fast charging protocol controller with plug in/out auto detection for HiSilicon Fast Charging Protocol (FCP) and Qualcomm® Quick Charge™ 2.0/3.0 (QC 2.0/3.0) USB interface. The FP6601AA monitors USB DPx/DNx data line and automatically adjusts the output voltage depending on different portable device requirement. The charging time of portable device is therefore optimized by the FP6601AA.

FP6601AA can support not only USB BC compliant devices, but also Apple / Samsung / HUAWEI devices and automatically detects whether a connected powered device is QC 2.0/3.0 or FCP capable before enabling output voltage adjustment. If a PD is not compliant with QC 2.0/3.0 and FCP, the FP6601AA will disable the adjustment of output voltage and keep the default 5V output voltage for safe operation.

Additionally, the FP6601AA also monitors automatically adjust the output voltage depending on different device requirement. It is capable providing output voltage of 3.6V to 12V.

### Features

- VDD Supply Voltage: 3.2V to 6.8V
- Supports HiSilicon Fast Charging Protocol (FCP)
- Supports Qualcomm® Quick Charge™ 2.0/3.0 Class A
- Automatically Selects FCP and QC2.0/3.0 Protocols
- Supports USB DCP Shorting D+ Line to D- Line per USB Battery Charging Specification, Revision 1.2
- Supports USB DCP Applying 2.7V on D+ Line and 2.7V on D- Line
- USB Type-A Plug In/Out Detection
- Multi-Ports Control Application
- Overvoltage Protection and VBUS Discharge Function
- Overcurrent and Short Circuit Protections
- LED Indicate Function
- CPC-20L Package

### Applications

- Wall-Adapter
- Car Charger
- Power Strip
- USB Power Output Port

### Pin Assignments

P6 Package CPC-20L

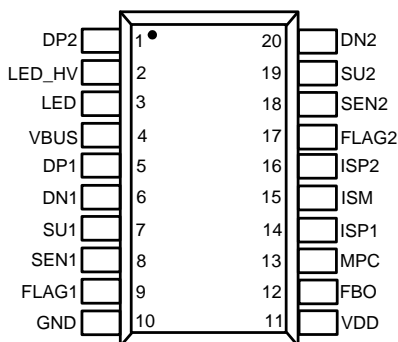

### Ordering Information

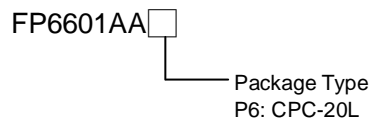

Typical Application Circuit

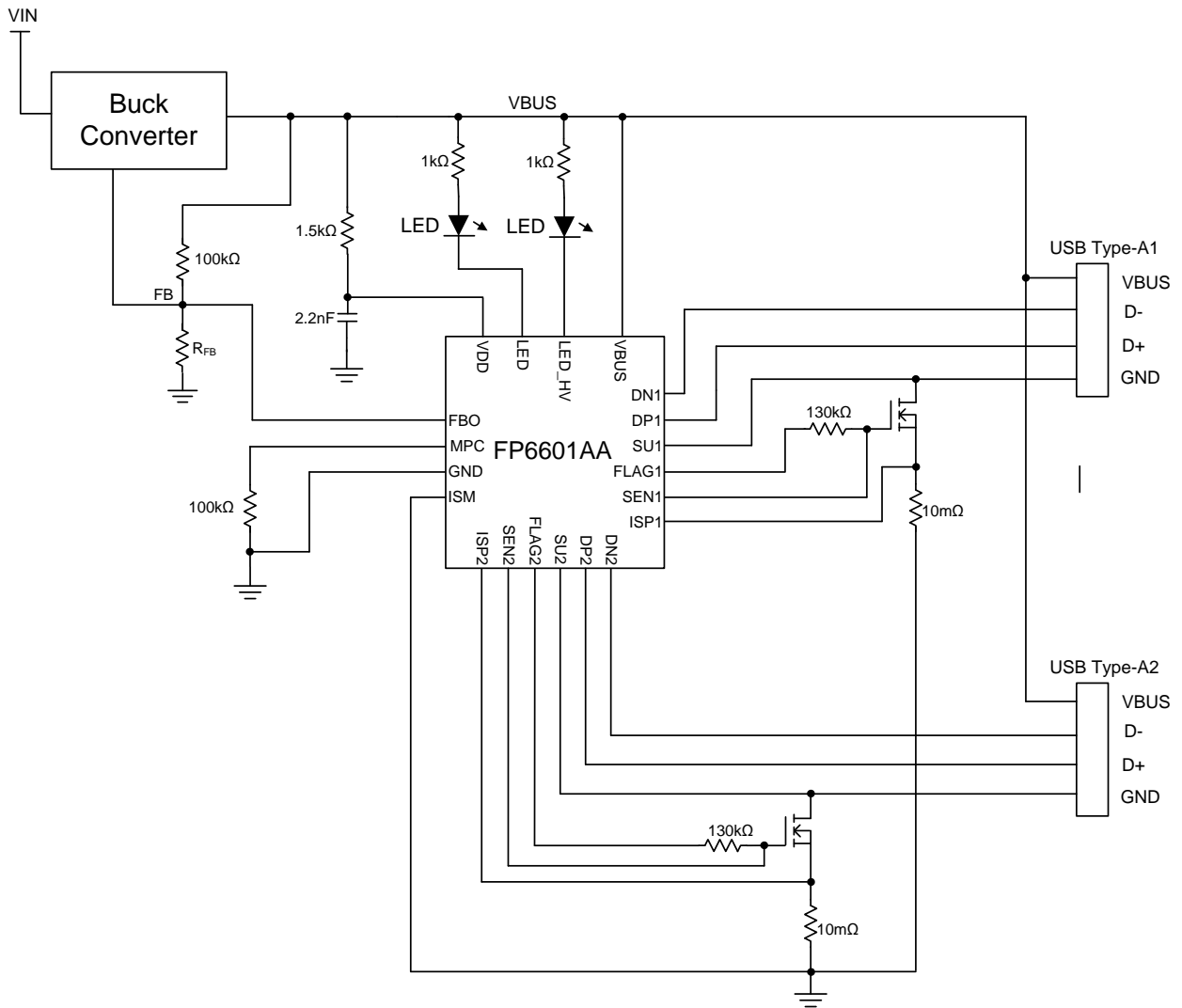

## Functional Pin Description

Pin Name	Pin No.	Pin Function
DP2	1	D+ data line of USB Type-A2. Recommended this pin connect without resistors(open) or with a resistor higher than 1MΩ connect to GND.
LED_HV	2	Indicate Function. If FP6601AA into fast charging mode, the LED_HV will light.
LED	3	Indicate Function. If FP6601AA is power good, the LED will light.
VBUS	4	VBUS voltage detection.
DP1	5	D+ data line of USB Type-A1. Recommended this pin connect without resistors(open) or with a resistor higher than 1MΩ connect to GND.
DN1	6	D- data line of USB Type-A1.
SU1	7	Sense voltage of USB Type-A1 connector plug in.
SEN1	8	Detection function Pin. Detect USB Type-A1 whether is device existence.
FLAG1	9	N-MOSFET gate node control. When USB Type-A1 plug in, FLAG1 will be activated high. Conversely, Type-A1 plug out, FLAG1 will be activated low.
GND	10	Ground pin.
VDD	11	Power supply input pin.
FBO	12	Output voltage control pin. Current sink function for FB node.
MPC	13	Multi-ports control. Connect a 100kΩ resistor to GND.
ISP1	14	Positive input of current sense amplifier of USB Type-A1. Connect to the current sense resistor on the VBUS power path.
ISM	15	Negative input of current sense amplifier of USB Type-A1 and A2. Connect to the current sense resistor on the VBUS power path.
ISP2	16	Positive input of current sense amplifier of USB Type-A2. Connect to the current sense resistor on the VBUS power path.
FLAG2	17	N-MOSFET gate node control. When USB Type-A2 plug in, FLAGA2 will be activated high. Conversely, Type-A2 plug out, FLAG2 will be activated low.
SEN2	18	Detection function Pin. Detect USB Type-A2 whether is device existence.
SU2	19	Sense voltage of USB Type-A2 connector plug in.
DN2	20	D- data line of USB Type-A2 port.

## Absolute Maximum Ratings <sup>(Note 1)</sup>

- Input Supply Voltage VDD----- -0.3V to +7V
- FBO, FLAGX----- -0.3V to +6.5V
- ISP<sub>x</sub>, ISM, MPC----- -0.3V to +6.5V
- DP<sub>x</sub>, DN<sub>x</sub>----- -0.3V to +18V
- VBUS, SU<sub>x</sub>, SEN<sub>x</sub>----- -0.3V to +18V
- HV\_LED, LED----- -0.3V to +18V
- Maximum Junction Temperature (T<sub>J</sub>)----- +150°C
- Storage Temperature (T<sub>S</sub>)----- -65°C to +150°C
- Lead Temperature (Soldering, 10sec.)----- +260°C
- Package Thermal Resistance, (θ<sub>JA</sub>) <sup>(Note 2)</sup>
  - CPC-20L----- TBD
- Package Thermal Resistance, (θ<sub>JC</sub>)
  - CPC-20L----- TBD

Note 1: Stresses beyond this listed under “Absolute Maximum Ratings” may cause permanent damage to the device.

Note 2: θ<sub>JA</sub> is measured at 25°C ambient with the component mounted on a high effective thermal conductivity test board of JEDEC-51-7.

## Recommended Operating Conditions

- Input supply voltage (VDD)----- 3.2V to 6.8V
- Operating temperature range (T<sub>A</sub>)----- -40°C to +125°C
- Junction temperature (T<sub>J</sub>)----- -40°C to +125°C

## Electrical Characteristics

(VDD=5V, T<sub>A</sub>=25°C and the recommended supply voltage range, unless otherwise specified.)

Parameter	Symbol	Conditions	Min	Typ	Max	Unit
<b>Input Power</b>						
VDD Input Voltage Range	V <sub>DD</sub>		3.2		6.8	V
Input UVLO Threshold	V <sub>DD_UVLO</sub>	V <sub>DD</sub> Rising	3.1	3.3	3.5	V
	V <sub>DD_HYS</sub>	V <sub>DD</sub> Falling	2.45	2.6	2.75	V
VDD Supply Current	I <sub>DD_SUP</sub>	V <sub>DD</sub> =5V, Nothing Attach	20	33	45	μA
VDD Shunt Voltage	V <sub>DD_SHDN</sub>		5.9	6.4	6.8	V
<b>VBUS</b>						
VBUS Over Voltage Protection			14.25	15	15.75	V
VBUS Bleed Discharge Resistance	R <sub>Bleed</sub>		8	10	12.5	kΩ
VBUS Discharge Resistance	R <sub>DIS</sub>			400		Ω
<b>USB Type-A</b>						
A_Plug in SUx Threshold	V <sub>TH_USBAIN</sub>		0.57	0.83	1.02	V
A_Plug in De-bounce Time	T <sub>USBAIN-DEB</sub>			200		μs
A_Plug out SUx Threshold	V <sub>TH_USBAOUT</sub>			0.2		V
DPDN OV Threshold	V <sub>DPDNOV</sub>			4		V
<b>High Voltage Dedicated Charging Port (HVDCP)</b>						
Data Detect Voltage	V <sub>DAT(REF)</sub>		0.25	0.325	0.4	V
Output Voltage Selection Reference	V <sub>SEL_REF</sub>		1.8	2.0	2.2	V
DPx High Glitch Filter Time	T <sub>GLITCH(BC)-DPA_H</sub>		1000	1250	1500	ms
DNx Low Glitch Filter Time	T <sub>GLITCH(BC)-DMA_L</sub>			1		ms
Output Voltage Glitch Filter Time	T <sub>GLITCH(V) CHANGE</sub>		20	40	60	ms
DNx Pull-Down Resistance	R <sub>DMA(DWN)</sub>			20		kΩ
Continuous Mode Glitch Filter Time	T <sub>GLITCH-CONT-CHANGE</sub>		100		200	μs
DPx Leakage Resistance	R <sub>DAT-LKG</sub>	V <sub>DD</sub> =3.2 to 6.4V VDPA=0.6-3.6V Switch SW 1=Off	300	500	800	kΩ
Switch SWx On-Resistance	R <sub>DS_ON_N1</sub>	V <sub>DD</sub> =5V, SW 1= 200μA			40	Ω
UP/Down Current Step	I <sub>UP</sub> , I <sub>DOWN</sub>	I <sub>UP</sub> = 0μA (5V), 40μA (9V) 70μA (12V) I <sub>DOWN</sub> = 14μA (3.6V)		2		μA

## Electrical Characteristics (Continued)

(VDD=5V, T<sub>A</sub>=25°C and the recommended supply voltage range, unless otherwise specified.)

Parameter	Symbol	Conditions	Min	Typ	Max	Unit
<b>DCP Charging Mode</b>						
DP <sub>x_0.48V</sub> / DN <sub>x_0.48V</sub> Line Output Voltage			0.44	0.48	0.52	V
DP <sub>x_0.48V</sub> / DN <sub>x_0.48V</sub> Line Output Impedance				900		kΩ
<b>Apple Mode</b>						
DP <sub>x_2.7V</sub> / DN <sub>x_2.7V</sub> Line Output Voltage			2.57	2.7	2.84	V
DP <sub>x_2.7V</sub> / DN <sub>x_2.7V</sub> Line Output Impedance				33.6		kΩ
<b>LED Indicate</b>						
LED		Power Good, VBUS=5V		1		mA
LED_HV		Fast Charge Mode		1		mA
<b>DNx SECTION (FCP)</b>						
DNx FCP Tx Valid Output High	V <sub>TX-VOH</sub>		2.55		3.6	V
DNx FCP Tx Valid Output Low	V <sub>TX-VOL</sub>				0.3	V
DNx FCP Rx Valid Output High	V <sub>RX-VIH</sub>		1.4		3.6	V
DNx FCP Rx Valid Output Low	V <sub>RX-VIL</sub>				1.0	V
DNx Output Pull-Low Resistance	R <sub>PD</sub>		400	500	600	Ω
Unit Interval for FCP PHY Communication	UI	F <sub>CLK</sub> =125kHz	144	160	180	μs
<b>Overcurrent Protection</b>						
Overcurrent Threshold	OCP			4.2		A

## Application Information

### Function Description

The FP6601AA integrates both USB high voltage dedicated charging port interface IC for Qualcomm<sup>®</sup> Quick Charge<sup>™</sup> 2.0/3.0 class A and HiSilicon FCP specification.

The FP6601AA can fast charge most of the handheld devices. It could be treated as the original charging adapter.

The FP6601AA supports BC1.2, Samsung and HUAWEI devices. It also supports output voltage range of C 3.0 Class A (3.6V to 12V) or QC 2.0 Class A (5V, 9V, 12V).

### Overcurrent Protection

FP6601AA could detect the current value with ISPAX and ISM pin to support the overcurrent protection(OCP). When OCP occur, FP6601AA turn off N-MOSFET through FLAGx pin. Protection states is hiccup.

### Quick Charge 2.0/3.0 Interface

When the FP6601AA is powered on, DPx and DNx pin are applied to 2.7V for Apple device. If handheld device has the function of QC 2.0/3.0, DPx pin will be forced between 0.325V and 2V. In the meanwhile, DPx pin will short to DNx pin through the switch SWx for entering BC 1.2. If DPA is continuously applied to the voltage between 0.325V and 2V for 1.25 seconds, the FP6601AA will enter QC 2.0/3.0 or FCP operation mode.

When the voltage of DPx pin and DNx pin simultaneously satisfy these two inequalities  $V_{DAT(REF)} < DPx < V_{SEL\_REF}$  and  $DNx > V_{SEL\_REF}$ , the FP6601AA would enter continuous mode.

In the continuous mode, each voltage pulse on DPx pin generated by powered device is between 1V and 3V. In the meanwhile, the high level of pulse should be keep at least 200 $\mu$ s. If the specified conditions are satisfied, the FBO pin will sink 2uA per pulse. The maximum sink current is 70 $\mu$ A for output voltage 12V.

If the powered device doesn't support QC 2.0, the FP6601AA will remain default output voltage 5V for safe operation. On the other hand, when USB cable is removed, the voltage of DPx pin is therefore lower than  $V_{DAT(REF)}$  and the output default voltage 5V is also applied.

### Shunt Regulator

The VDD of FP6601AA is supplied by the wide output voltage through the external resistor RVDD. The internal Zener-Diode is utilized to clamp the VDD at 6.4V. The recommended value of RVDD and CVDD are 1.5k $\Omega$  and 2.2nF, respectively.

### Multi-Ports Control

Use for single VBUS source and multi USB channel applications. Connect all MPC pins on different Fitipower USB ICs together and connect a 100k $\Omega$  resistor to GND. FP6601AA will auto detect the attachments between all Fitipower USB ICs and will auto decide multi-ports operation is allowed or not.

### Data Line Protection

When DPx/DNx pin is touched by the external power in abnormal situation, the D+/D- pin of both sink device and source device may be damaged. In order to protect the DPx/DNx pin of the devices from damage in abnormal situation, the FP6601AA will return the output voltage to default output voltage 5V when the voltage of DPx/DNx pin is higher than 7.5V.

### Plug in/out Auto Detection

When device plugs in or out , the FP6601AA can auto detect and into standby or operation mode:

1. Plug In detection is used for USB device plug in.  
When device plug in, FLAGx pin alerts active high.
2. Plug Out detection is used for USB device plug out.  
When plug out detected, FLAGx pin active low.

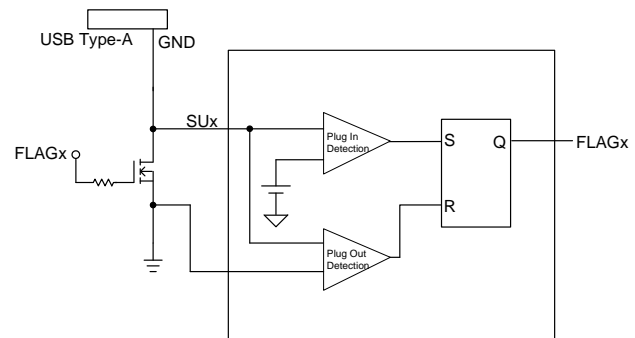

## Outline Information

CPC-20L Package (Unit: mm)

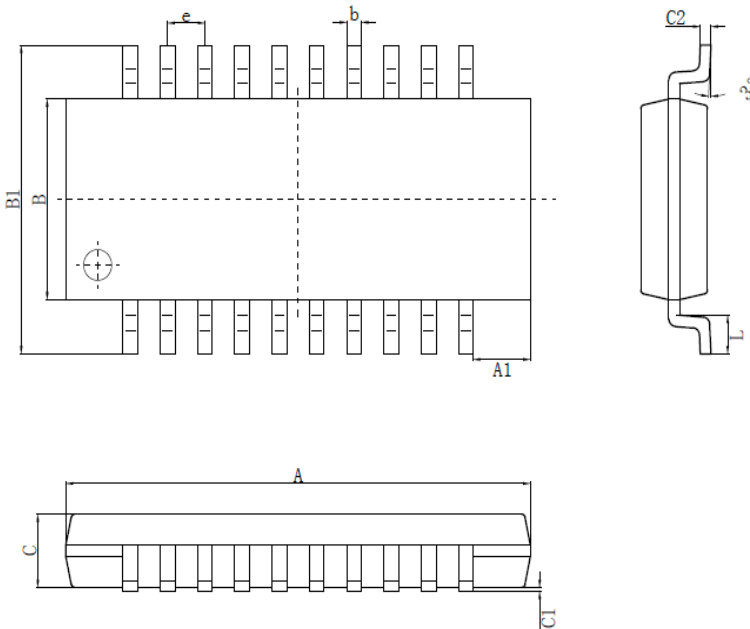

SYMBOLS UNIT	DIMENSION IN MILLIMETER	
	MIN	MAX
A	6.50	6.70
A1	0.76	0.86
B	2.50	2.70
B1	3.85	4.15
C	0.85	1.05
C1	0.00	0.15
C2	0.15	0.18
e	0.53(BSC)	
b	0.16	0.26
L	0.40	0.60

## Carrier dimensions

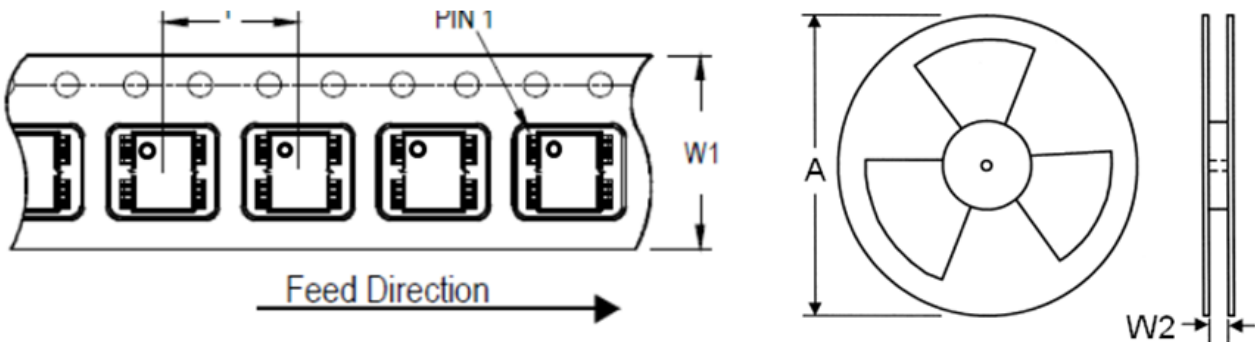

Tape Size (W1) mm	Pocket Pitch (P) mm	Reel Size (A)		Reel Width (W2) mm	Empty Cavity Length mm	Units per Reel
		in	mm			
12	8	15	380	12.5	300~1000	6,000

### Life Support Policy

Fitipower's products are not authorized for use as critical components in life support devices or other medical systems.