

700mA LED Driver with Internal Switch



General Description

The FP7151 is a continuous mode inductive step down converter. It can driving single or multiple series connected LEDs. The FP7151 includes the output switch and a high-side output current sensing circuit, which use an external resistor to set the average output current. Output current can also be adjusted by applying an external signal to the 'ADJ' pin. The ADJ pin will accept either a DC voltage or a PWM waveform. The PWM filter components are contained within the chip. Applying a voltage under 0.2V to the ADJ pin will turn off the output.

The FP7151 is available in the SOT23-5L package and provides space-saving PCB for the application fields.

Features

- 700mA Output Current
- Internal 0.7Ω 26V Power MOSFET Switch
- Wide 7 to 26V Operating Input Range
- 20μA Shutdown Mode Current
- Typical 4% Output Current Accuracy
- Signal pin ON / OFF and Brightness Control
- Adjustable Soft-Start
- Up to 95% Efficiency
- Up to 1MHz Switching Frequency
- Internal Dimming Filter
- Package: SOT23-5L

Applications

- Low Voltage Halogen replacement LEDs
- LED back-up lighting

Typical Application Circuit

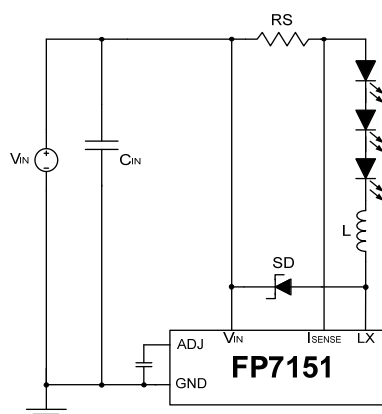

This datasheet contains new product information. Feeling Technology reserves the rights to modify the product specification without notice. No liability is assumed as a result of the use of this product. No rights under any patent accompany the sales of the product.

Function Block Diagram

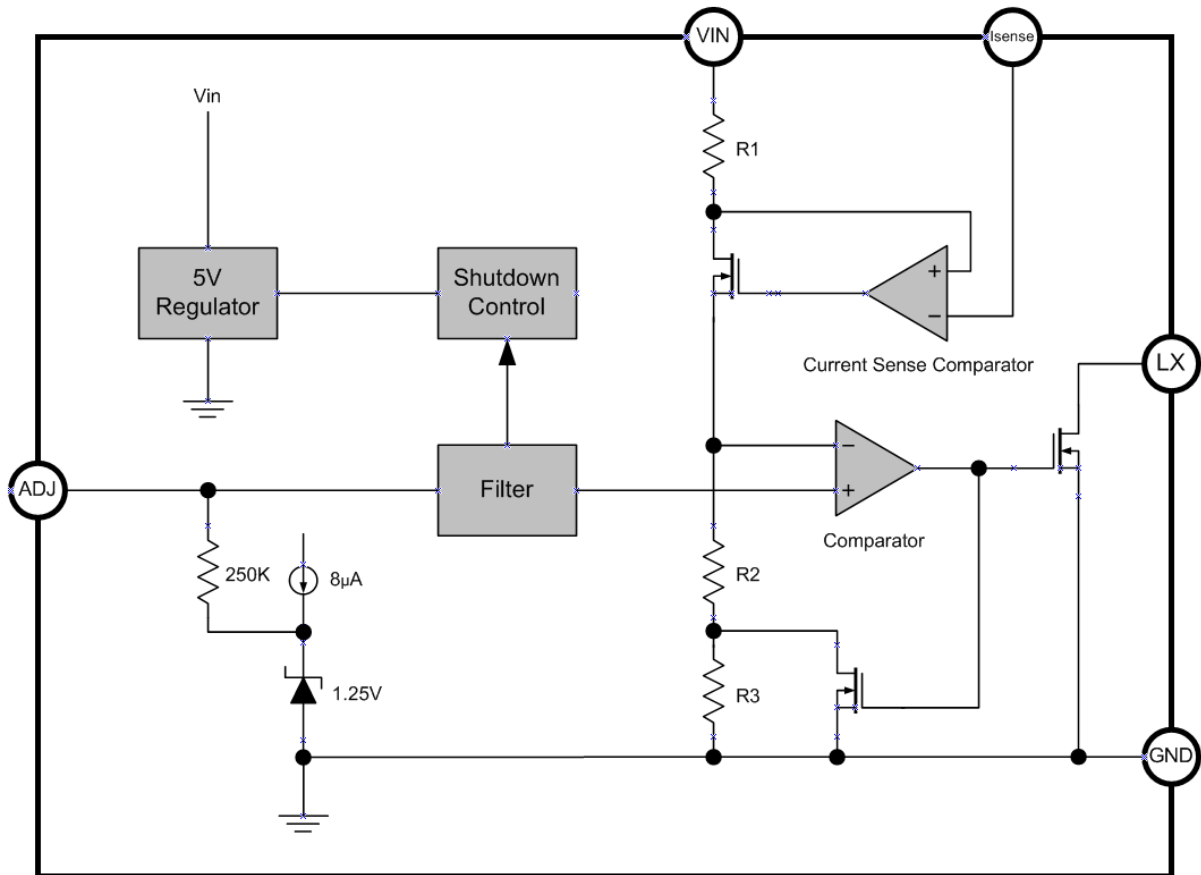

Pin Descriptions

SOT23-5L

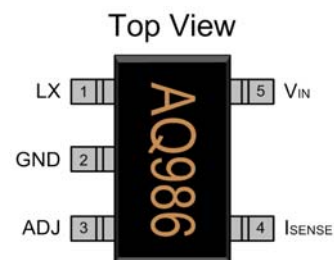

Name	No.	I / O	Description
LX	1	O	Power Switch Output
GND	2	P	IC Ground
ADJ	3	I	Multi Function ON / OFF& Brightness Control
ISENSE	4	I	Current Sense Resistor Connected
V _{IN}	5	P	IC Power Supply

This datasheet contains new product information. Feeling Technology reserves the rights to modify the product specification without notice. No liability is assumed as a result of the use of this product. No rights under any patent accompany the sales of the product.

Marking Information

SOT23-5L

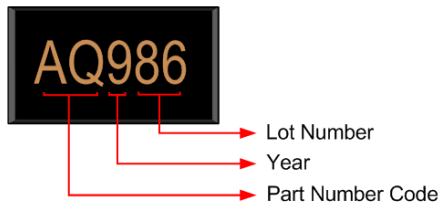

Lot Number: Wafer lot number's last two digits

For Example: 132362TB → 62

Year: Production year's last digit

Part Number Code: Part number identification code for this product. It should be always "AQ".

Ordering Information

Part Number	Code	Operating Temperature	Package	MOQ	Description
FP7151KR-G1	AQ	-40°C ~ 85°C	SOT23-5L	3000EA	Tape & Reel

Absolute Maximum Ratings

Parameter	Symbol	Conditions	Min.	Typ.	Max.	Unit
Supply Voltage	V_{IN}		-0.3		26	V
I_{SENSE} Voltage	V_{SENSE}	Measured with Respect to V_{IN}	+0.3		-5	V
LX Input Voltage	V_{LX}		-0.3		26	V
Adjust Pin Input Voltage	V_{ADJ}		-0.3		6	V
Power Dissipation	P_D	SOT23-5L @ $T_A=25^\circ\text{C}$			570	mW
Thermal Resistance (Note1)	θ_{JA}	SOT23-5L			+220	$^\circ\text{C} / \text{W}$
Junction Temperature	T_J				+150	$^\circ\text{C}$
Operating Temperature	T_{OP}		-40		+85	$^\circ\text{C}$
Storage Temperature	T_{ST}		-65		+150	$^\circ\text{C}$
Lead Temperature		(soldering, 10 sec)			+260	$^\circ\text{C}$

Note1:

θ_{JA} is measured in the natural convection at $T_A=25^\circ\text{C}$ on a low effective thermal conductivity test board of JEDEC 51-3 thermal measurement standard.

IR Re-flow Soldering Curve

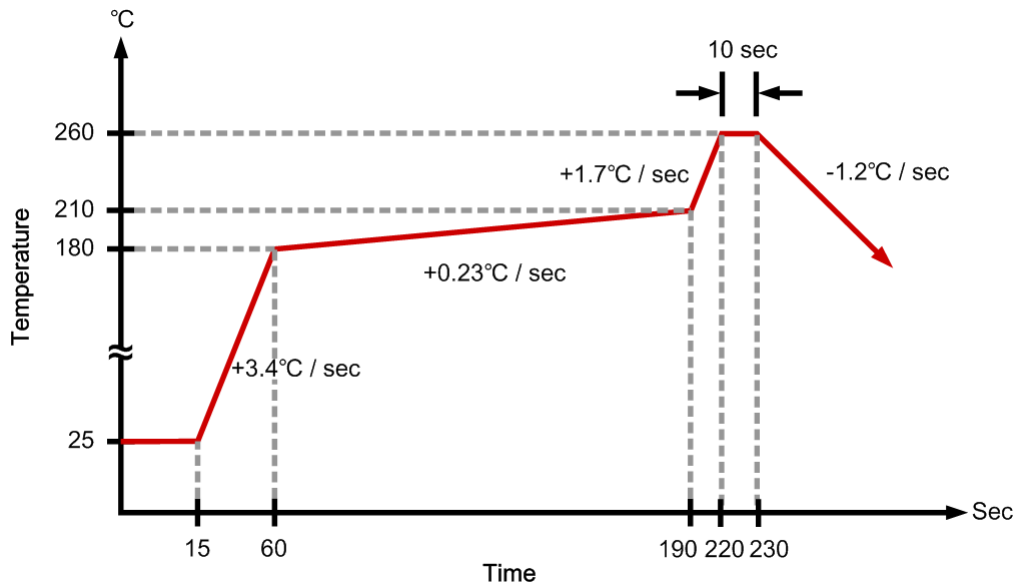

This datasheet contains new product information. Feeling Technology reserves the rights to modify the product specification without notice. No liability is assumed as a result of the use of this product. No rights under any patent accompany the sales of the product.

DC Electrical Characteristics $V_{IN}=12V$, $T_A=25^{\circ}C$ (unless otherwise specified)

Parameter	Symbol	Conditions	Min.	Typ.	Max.	Unit
Input voltage	V_{IN}		7		26	V
Internal Regulator Start-up Threshold	V_{SU}	V_{IN} Rising		4.8		V
Quiescent Supply Current with Output off	I_{INQoff}	ADJ pin Grounded		15	20	μA
Quiescent Supply Current with Output Switching	I_{INQon}	ADJ pin Floating $f=250kHz$		400	800	μA
Mean Current Sense Threshold Voltage (Defines LED Current Setting Accuracy)	V_{SENSE}	Measured on I_{SENSE} pin with Respect to V_{IN} $V_{ADJ}=1.25V$	95	100	105	mV
Sense Threshold Hysteresis	$V_{SENSEHYS}$			± 15		%
I_{SENSE} pin Input Current	I_{SENSE}	$V_{SENSE}=V_{IN}-0.1$		3	10	μA
Internal Reference Voltage	V_{REF}	Measured on ADJ pin with pin Floating	1.21	1.25	1.29	V
Temperature Coefficient of V_{REF}	$\Delta V_{REF} / \Delta T$			50		ppm/ $^{\circ}C$
External Control Voltage Range on ADJ pin for Dc Brightness Control ⁽¹⁾	V_{ADJ}		0.3		2.5	V
DC Voltage on ADJ pin to Switch Device from Active (on) State to Quiescent (off) State	V_{ADJoff}	V_{ADJ} Falling	0.15	0.2	0.25	V
DC Voltage on ADJ pin to Switch Device from Quiescent (off) state to Active (on) State	V_{ADJon}	V_{ADJ} Rising	0.2	0.25	0.3	V
Resistance Between ADJ pin and V_{REF}	R_{ADJ}		135		250	k Ω
Continuous LX Switch Current	I_{LXmean}				0.7	A
LX Switch 'On' Resistance	R_{LX}			0.7	0.9	Ω
LX Switch Leakage Current	$I_{LX(leak)}$				1	μA

This datasheet contains new product information. Feeling Technology reserves the rights to modify the product specification without notice. No liability is assumed as a result of the use of this product. No rights under any patent accompany the sales of the product.

DC Electrical Characteristics (Cont.) $V_{IN}=12V$, $T_A=25^{\circ}C$ (unless otherwise specified)

Parameter	Symbol	Conditions	Min.	Typ.	Max.	Unit
Duty cycle range of PWM signal applied to ADJ pin during low frequency PWM dimming mode	$D_{PWM(LF)}$	PWM frequency <500Hz PWM amplitude= V_{REF} Measured on ADJ pin	0.01		1	
Brightness Control Range						
Duty cycle range of PWM signal applied to ADJ pin during high frequency PWM dimming mode	$D_{PWM(HF)}$	PWM frequency >10kHz PWM amplitude= V_{REF} Measured on ADJ pin	0.16		1	
Brightness Control Range						
Soft Start Time	T_{SS}	Time taken for output current to reach 90% of final Value after voltage on ADJ pin has risen above 0.3V			500	μs
Operating Frequency (See Graphs for more Detail)	f_{LX}	ADJ pin floating $L=100\mu H$ (0.82 Ω) $I_{OUT}=700mA$ @ $V_{LED}=3.4V$ Driving 1 LED			250	KHz
Minimum Switch 'ON' Time	T_{ONmin}	LX switch 'ON'	200			ns
Minimum Switch 'OFF' Time	T_{OFFmin}	LX switch 'OFF'	200			ns
Recommended Maximum Operating Frequency	f_{LXmax}				1	MHz
Recommended Duty Cycle Range of Output Switch at f_{LXmax}	D_{LX}		0.3		0.7	
Internal Comparator Propagation Delay	T_{PD}				50	ns

Notes :

- 100% brightness corresponds to $V_{ADJ} = V_{ADJ}(\text{nom}) = V_{REF}$. Driving the ADJ pin above V_{REF} will increase the V_{SENSE} threshold and output current proportionally.

This datasheet contains new product information. Feeling Technology reserves the rights to modify the product specification without notice. No liability is assumed as a result of the use of this product. No rights under any patent accompany the sales of the product.

Typical Operating Characteristics

($V_{CC}=12V$, Single LED, $T_A=25^\circ C$, $L=100\mu H$, unless otherwise noted)

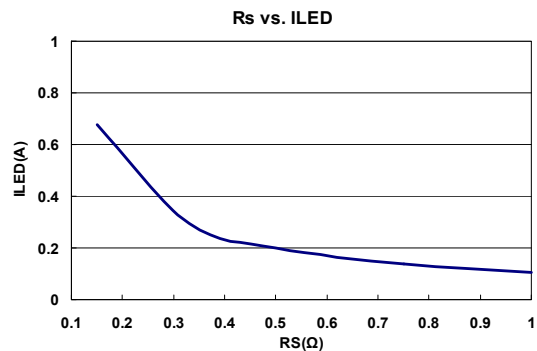
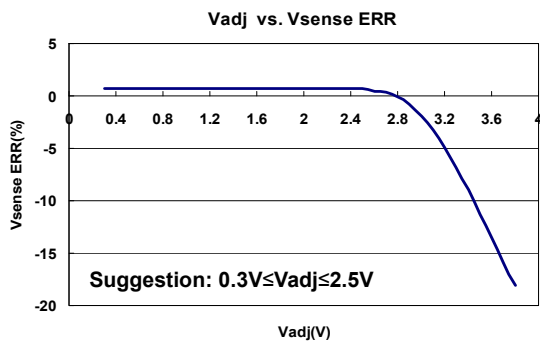
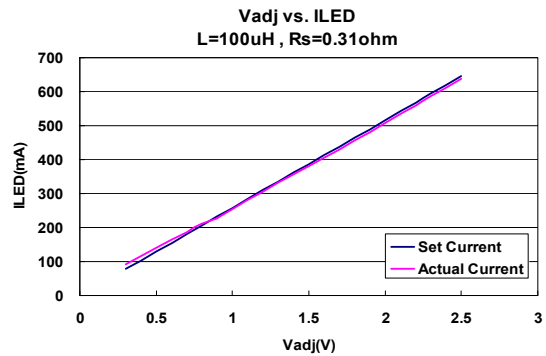
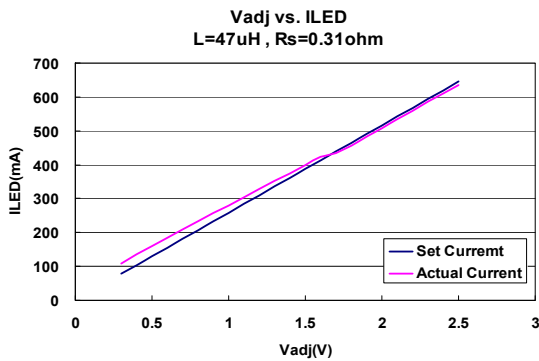
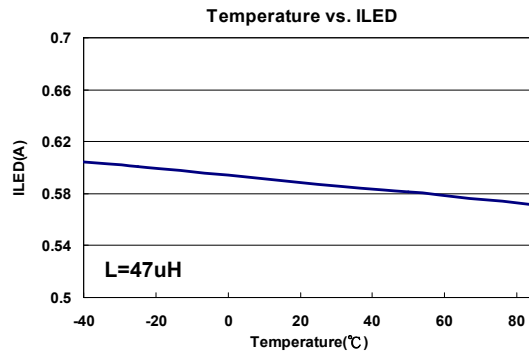
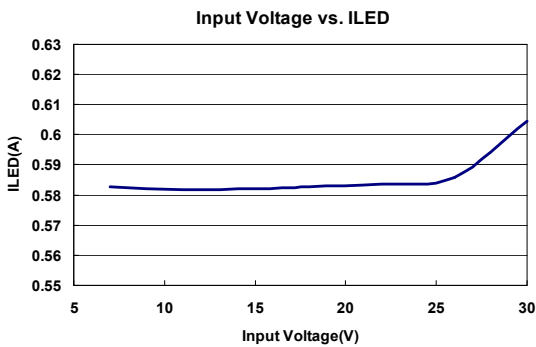
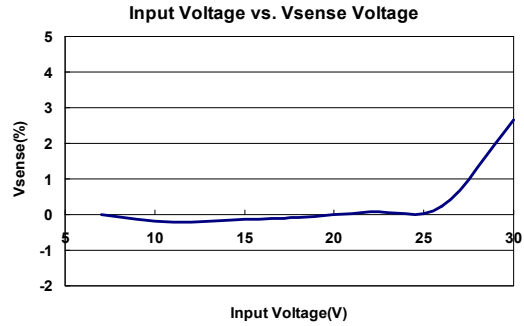
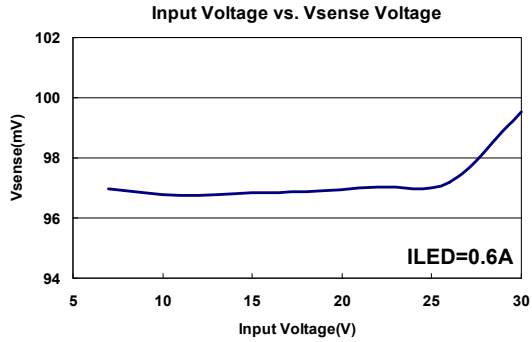

This datasheet contains new product information. Feeling Technology reserves the rights to modify the product specification without notice. No liability is assumed as a result of the use of this product. No rights under any patent accompany the sales of the product.

Function Description

Operation

The FP7151 is a continuous mode inductive step-down converter that is easily to be configured in varies applications ranging from 7V~26V input. The converter employs a high side current sensing resistor RS to detect and regulate the LED current. The voltage across the current sensing resistor is kept measured and regulated in 100mV±15mV range.

The internal 1.25V reference voltage is utilized to provide a 0.25V reference for enabling the part and a 1.25V pulling-up voltage as current reference voltage. When $V_{ADJ} > 0.25V$ the output of the comparator becomes high and the other blocks are enabled.

When input voltage VIN is first applied, the initial current in L1 and RS is zero and there is no output from the current sense circuit. Under this condition, the output of comparator is high. This turns on an internal switch and switches the SW pin low, causing current to flow from VIN to ground, via RS, L1 and the LED(s). The current rises at a rate determined by VIN and L1 to produce a voltage ramp across RS. When $(V_{IN} - V_{SENSE}) > 115mV$, the output of Comparator switches low and the switch turns off. The current flowing on the RS decreases at another rate. When $(V_{IN} - V_{SENSE}) < 85mV$, the switch turns on again and the mean current on the LED is $100mV/R_S$.

Adjusting output current

The device contains a low pass filter between the ADJ pin and the threshold comparator and an internal current limiting resistor (250k nom) between ADJ and the internal reference voltage. This allows the ADJ pin to be overdriven with either DC or pulse signals to change the V_{SENSE} switching threshold and adjust the output current.

Output Shutdown

The output of the low pass filter drives the shutdown circuit. When the input voltage to this circuit falls below the threshold (0.2V nom), the internal regulator and the output switch are turned off. The voltage reference remains powered during shutdown to provide the bias current for the shutdown circuit. Quiescent supply current during shutdown is nominally 15uA and switch leakage is below 1uA.

Dimming Control

The FP7151 provides two dimming methods: PWM dimming and DC analog dimming. To use PWM dimming, apply a square wave to the EN/DIM pin. To used analog dimming, apply a 0.3V~2.5V DC voltage to this pin.

Application Information

Setting the LED Current

The LED current is identical and set by the current setting resistor between the V_{IN} pin and I_{SENSE} pin. To set the LED current according to the following equation:

$$I_{LED} = \frac{0.1}{R_S}$$

For $R_S=0.33\Omega$, the LED current is set to 300mA

Shutdown Mode

Taking the ADJ pin to a voltage below 0.2V will turn off the output and the supply current will fall to a low standby level of 15 μ A nominal.

Soft Start

The voltage on the ADJ pin is the inductor current reference. An external capacitor from the ADJ pin to ground provides a soft-start delay. When V_{IN} starts, internal voltage source charges the capacitor from 0V to 1.25V to fulfill soft-start function.

Capacitor selection

A low ESR capacitor should be used for input decoupling, as the ESR of this capacitor appears in series with the supply source impedance and lowers overall efficiency. This capacitor has to supply the relatively high peak current to the coil and smooth the current ripple on the input supply. A minimum value of 4.7 μ F is acceptable if the input source is close to the device, but higher values will improve performance at lower input voltages, especially when the source impedance is high. The input capacitor should be placed as close as possible to the IC.

For maximum stability over temperature and voltage, capacitors with X7R, X5R, or better dielectric are recommended. Capacitors with Y5V dielectric are not suitable for decoupling in this application and should not be used.

Reducing output ripple

Peak to peak ripple current in the LED(s) can be reduced, if required, by shunting a capacitor C_{LED} across the LED(s)

Inductor selection

Recommended inductor values for the FP7151 are in the range 47uH to 100uH. Higher values of inductance are recommended at higher supply voltages in order to minimize errors due to switching delays, which result in increased ripple and lower efficiency. Higher values of inductance also result in a smaller change in output current over the supply voltage range. The inductor should be mounted as close to the device as possible with low resistance connections to the LX and VIN pins. The chosen coil should have a saturation current higher than the peak output current and a continuous current rating above the required mean output current.

DC Dimming

$I_{OUTDC} = 0.08 \cdot V_{ADJ} / R_S$ [for $0.3 < V_{ADJ} < 2.5V$]. The ADJ pin can be driven by an external DC voltage (V_{ADJ}), to adjust the output current to a value below the nominal average value defined by R_S . The LED current decreases linearly with the V_{ADJ} when $0.3V \leq V_{ADJ} \leq 2.5V$, R_S must be increased in proportion to prevent I_{OUTDC} exceeding 700mA maximum. When the V_{ADJ} falls below the threshold, 0.2V, the output switch is turned off which allows PWM dimming.

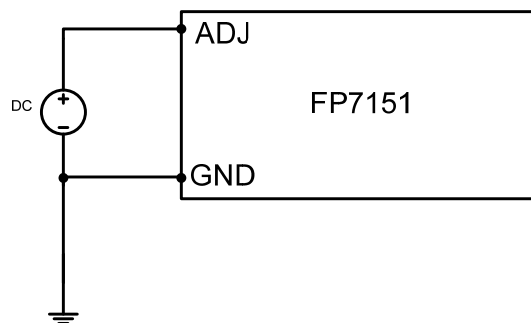

PWM Dimming

A Pulse Width Modulated (PWM) signal with duty cycle D_{PWM} can be applied to the ADJ pin, The PWM signal is recommended above 50kHz. As shown below, to adjust the output current to a value above or below the nominal average value set by resistor R_S :

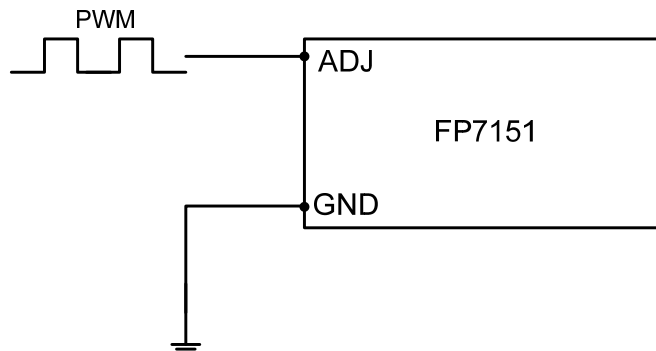

PC Board Layout Checklist

1. the capacitor C1 has to be placed as close as possible to V_{IN}
2. The sense resistor RS has to be placed as close as possible to V_{IN} and I_{SENSE}
3. The D1 anode, the SW pin and the inductor L1 have to be placed as close as possible to avoid ringing

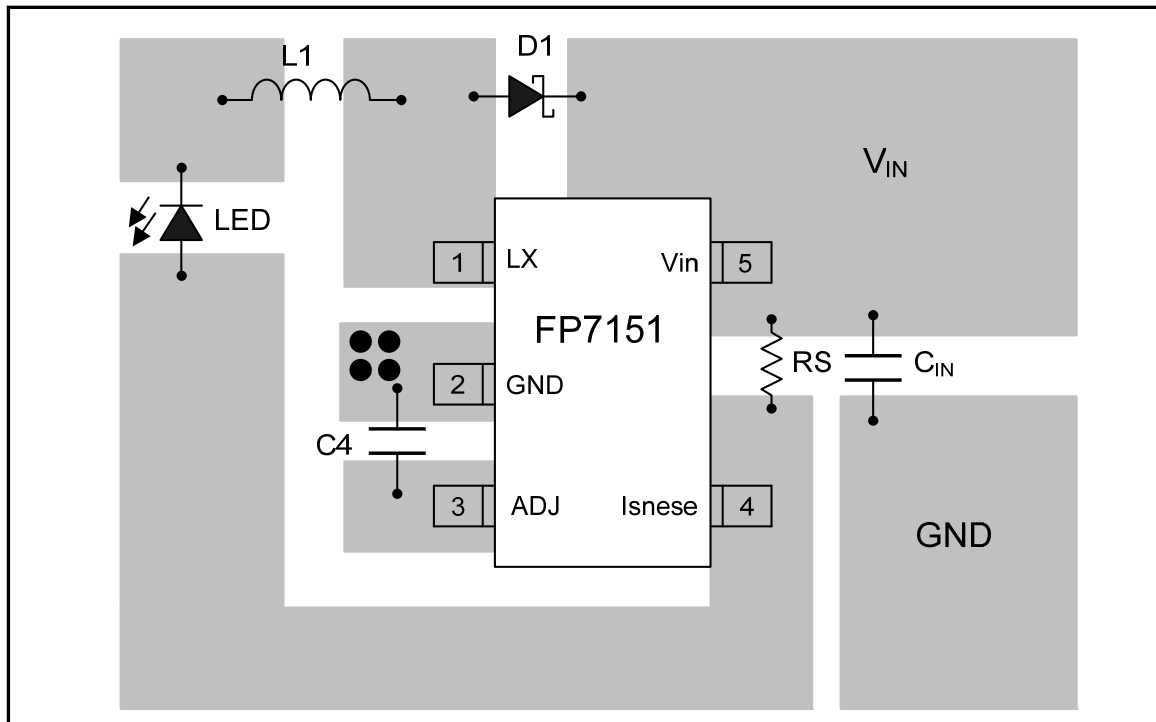
Suggested Layout

Typical Application

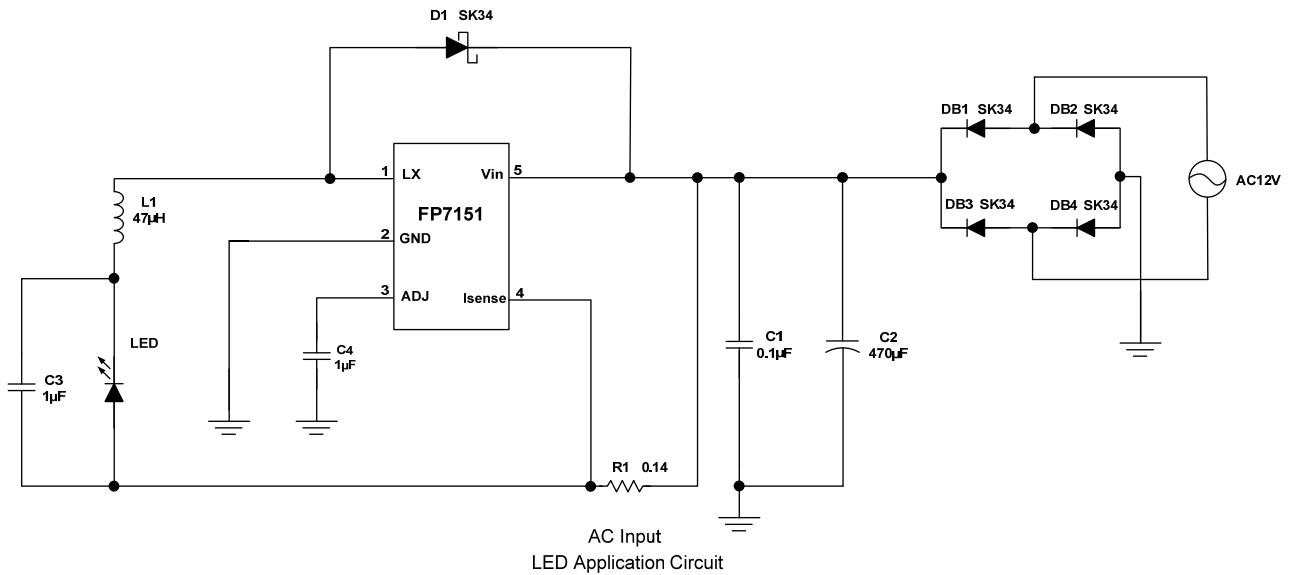
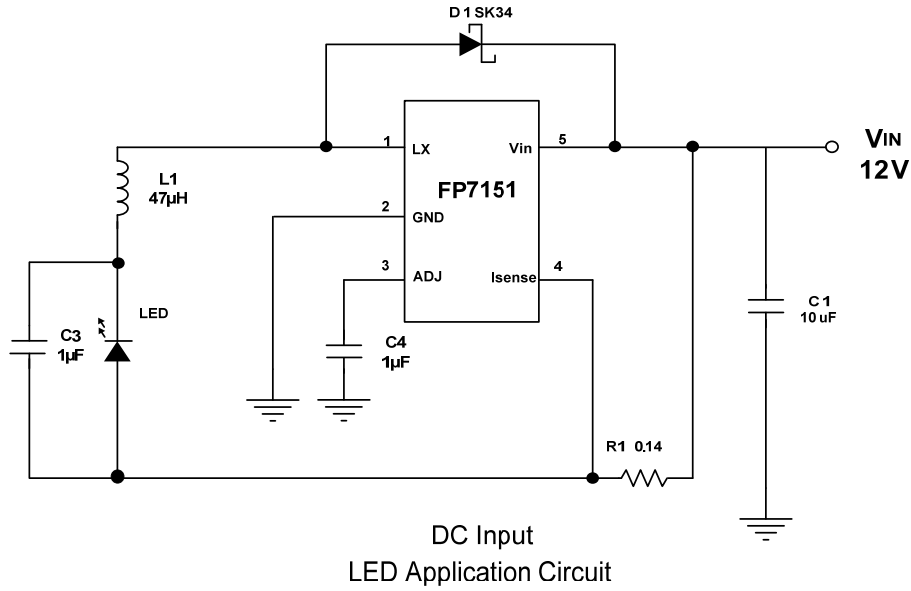

This datasheet contains new product information. Feeling Technology reserves the rights to modify the product specification without notice. No liability is assumed as a result of the use of this product. No rights under any patent accompany the sales of the product.

Package Outline

SOT23-5L

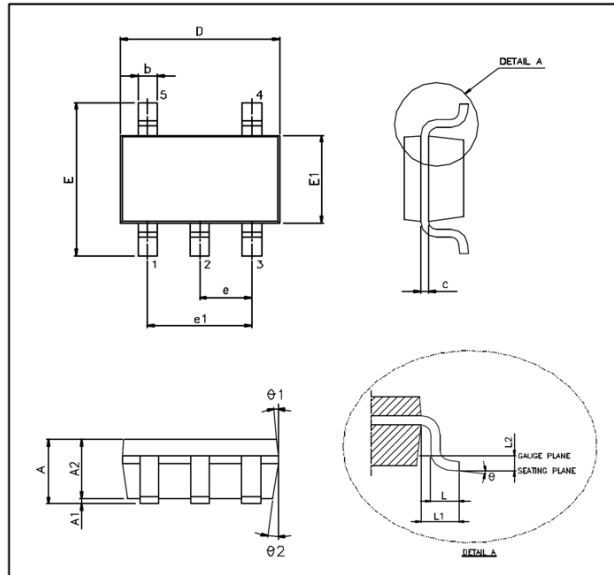
UNIT: mm

Symbols	Min. (mm)	Max.(mm)
A	1.050	1.350
A1	0.050	0.150
A2	1.000	1.200
b	0.250	0.500
c	0.080	0.200
D	2.700	3.000
E	2.600	3.000
E1	1.500	1.700
e	0.950 BSC	
e1	1.900 BSC	
L	0.300	0.550
L1	0.600 REF	
L2	0.250 BSC	
θ°	0°	10°
$\theta1^\circ$	3°	7°
$\theta2^\circ$	6°	10°

Note:

1. Package dimensions are in compliance with JEDEC outline: MO-178 AA.
2. Dimension “D” does not include molding flash, protrusions or gate burrs.
3. Dimension “E1” does not include inter-lead flash or protrusions.

This datasheet contains new product information. Feeling Technology reserves the rights to modify the product specification without notice. No liability is assumed as a result of the use of this product. No rights under any patent accompany the sales of the product.