

## Constant Current Switching Regulator for White LED



### General Description

The FP7201 is a Boost DC-DC converter specifically designed to drive white LEDs with constant current. The device can support 2 to 7 white LEDs for backlighting and camera flashing. This high efficient regulator and internal compensation network minimizes as 5 external component counts. Optimized operation frequency can meet the requirement of small LC filters value and low operation current with high efficiency. The non-inverting input of error amplifier connects to a 0.25V precision reference voltage and internal soft-start function can reduce the inrush current.

The FP7201 is available in the TSOT23-6L package and provides space-saving PCB for diverse application fields.

### Features

- Precision Feedback Reference Voltage: 0.25V (4%)
- Under Voltage Lockout Protection
- Over Voltage Protection
- Over Temperature Protection
- Wide Frequency Range and Dimming with Zero-Inrush Current
- Internal Soft-Start
- Zero Shutdown Current
- Adjustable Output up to 26V
- Package: TSOT23-6L

### Applications

- Smart Phone LED Backlights
- Digital Cameras
- Camcorders
- PDA LED Backlights

### Typical Application Circuit

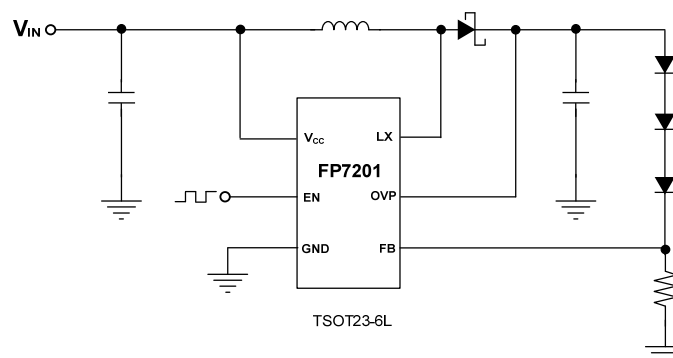

This datasheet contains new product information. Feeling Technology reserves the rights to modify the product specification without notice. No liability is assumed as a result of the use of this product. No rights under any patent accompany the sales of the product.

## Function Block Diagram

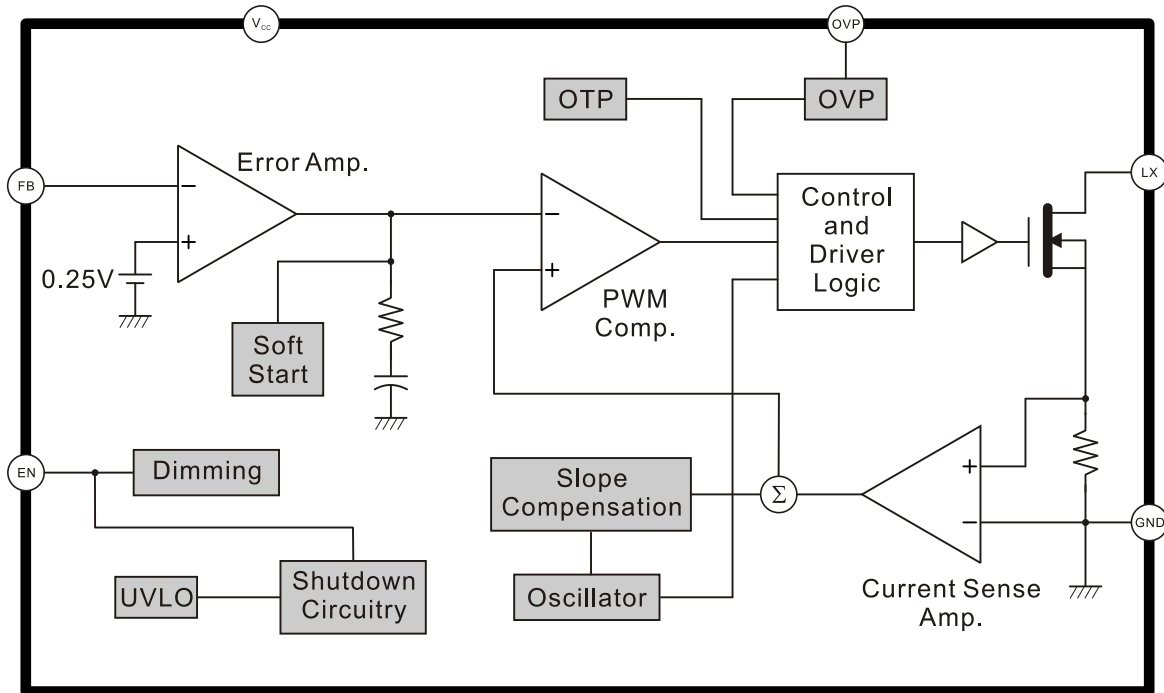

## Pin Descriptions

### TSOT23-6L

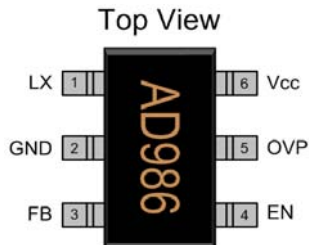

Name	No.	I / O	Description
LX	1	O	Power Switch Output
GND	2	P	Ground
FB	3	I	Error Amplifier Inverting Input
EN	4	I	Enable Control (Active High)
OVP	5	O	Over Voltage Protection
V <sub>CC</sub>	6	P	IC Power Supply

This datasheet contains new product information. Feeling Technology reserves the rights to modify the product specification without notice. No liability is assumed as a result of the use of this product. No rights under any patent accompany the sales of the product.

## Marking Information

TSOT23-6L

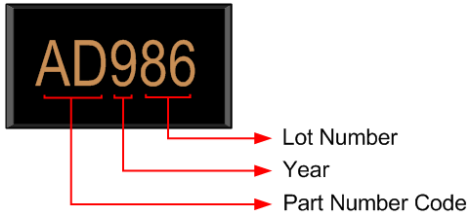

**Lot Number:** Wafer lot number's last two digits

For Example: 132386TB → 86

**Year:** Production year's last digit

**Part Number Code:** Part number identification code for this product. It should be always "AD".

### Ordering Information

Part Number	Part Number Code	Operating Temperature	Package	MOQ	Description
FP7201hR-G1	AD	-40°C ~ +85°C	TSOT23-6L	3000EA	Tape & Reel

### Absolute Maximum Ratings

Parameter	Symbol	Conditions	Min.	Typ.	Max.	Unit
Supply Voltage	$V_{CC}$				6	V
OVP Voltage					28	V
LX Input Voltage			-0.3		28	V
EN, FB Voltage			-0.3		6	V
Allowable Power Dissipation		$T_A \leq +25^\circ\text{C}$			455	mW
Thermal Resistance	$\theta_{JA}$				+220	$^\circ\text{C} / \text{W}$
Junction Temperature					+150	$^\circ\text{C}$
Operating Temperature			-40		+85	$^\circ\text{C}$
Storage Temperature			-65		+150	$^\circ\text{C}$
TSOT23-6L Lead Temperature		(soldering, 10 sec)			+260	$^\circ\text{C}$

### IR Re-flow Soldering Curve

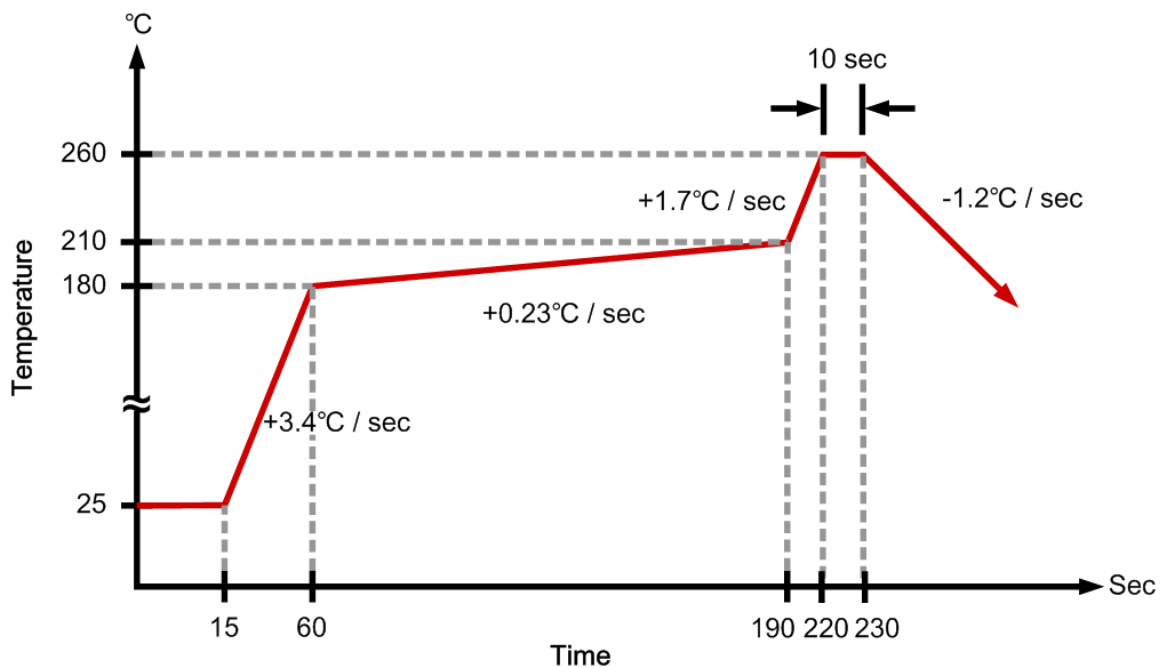

This datasheet contains new product information. Feeling Technology reserves the rights to modify the product specification without notice. No liability is assumed as a result of the use of this product. No rights under any patent accompany the sales of the product.

## Recommended Operating Conditions

Parameter	Symbol	Conditions	Min.	Typ.	Max.	Unit
Junction Temperature Range			-40		+125	°C
Ambient Temperature Range			-40		+85	°C

## DC Electrical Characteristics ( $V_{CC}=3.7V$ , $T_A=25^\circ$ , unless otherwise specified)

Parameter	Symbol	Conditions	Min.	Typ.	Max.	Unit
<b>System Supply Input</b>						
Input Supply Range	$V_{CC}$		2.7		5.5	V
Under Voltage Lockout	$V_{UVLO}$			2.2		V
Quiescent Current	$I_{CC}$	$V_{FB}=0.3V$ , No switching		0.3		mA
Average Supply Current	$I_{CC}$	$V_{FB}=0V$ , Switching		0.5		mA
Shutdown Supply Current	$I_{CC}$	$V_{EN}=GND$		0.1		$\mu A$
<b>Oscillator</b>						
Operation Frequency	$F_{OSC}$	$V_{FB}=1.0V$	0.9	1.2	1.5	MHz
Frequency Change with Voltage	$\Delta f / \Delta V$	$V_{CC}=2.7V$ to $5.5V$		2		%
Frequency Change with Temperature	$\Delta f / \Delta T$	$T_A=-40^\circ C$ to $85^\circ C$		10		%
Maximum Duty Cycle	$T_{DUTY}$		85			%
<b>Reference Voltage</b>						
Feedback Voltage	$V_{REF}$		0.24	0.25	0.26	V
Feedback Voltage Change with Temperature	$\Delta V_{REF} / \Delta T$	$T_A=-40^\circ C$ to $25^\circ C$		1.5		%
		$T_A=25^\circ C$ to $85^\circ C$		1.5		
Line Regulation		$V_{CC}=2.7V \sim 5.5V$		0.01		% / V
<b>MOSFET</b>						
On Resistance of Driver	$R_{DS(ON)}$	$I_{LX}=0.1A$		0.75		$\Omega$
<b>Protection</b>						
OVP Threshold Voltage	$V_{OVP}$			27		V
OVP Sink Current	$I_{SINK}$			5		$\mu A$
OCP Current	$I_{OCP}$			750		mA
OTP Temperature	$T_{OTP}$			+150		°C
Enable Voltage	$V_{EN}$		1.5			V
Shutdown Voltage	$V_{EN}$				0.4	V

This datasheet contains new product information. Feeling Technology reserves the rights to modify the product specification without notice. No liability is assumed as a result of the use of this product. No rights under any patent accompany the sales of the product.

## Typical Operating Characteristics

( $V_{CC}=3.7V$ ,  $T_A=25^\circ$ , unless otherwise specified)

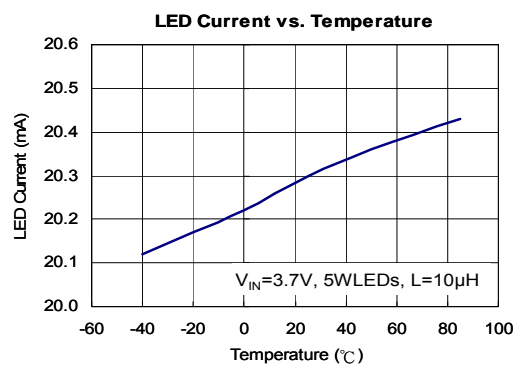
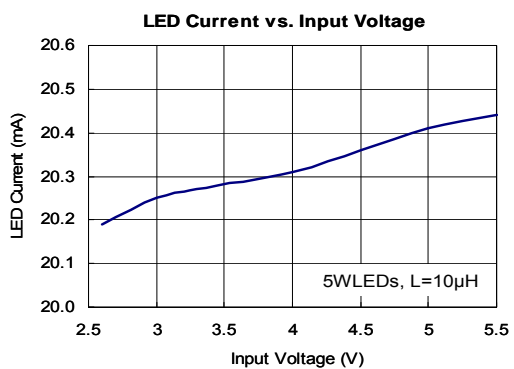
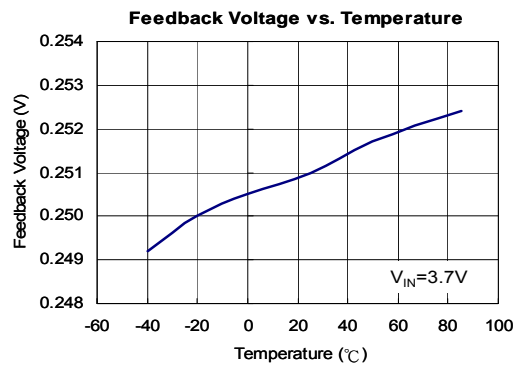
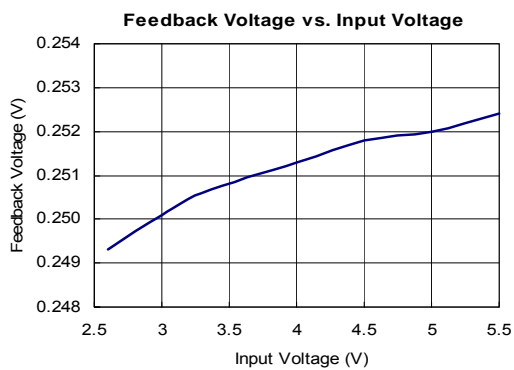
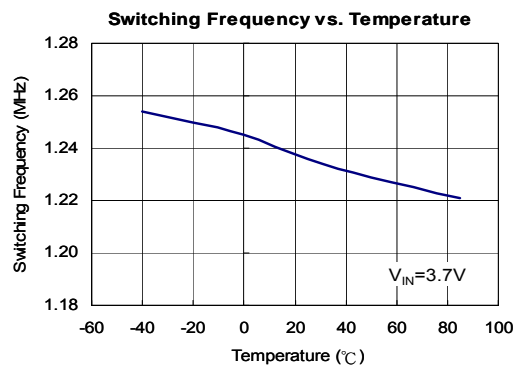
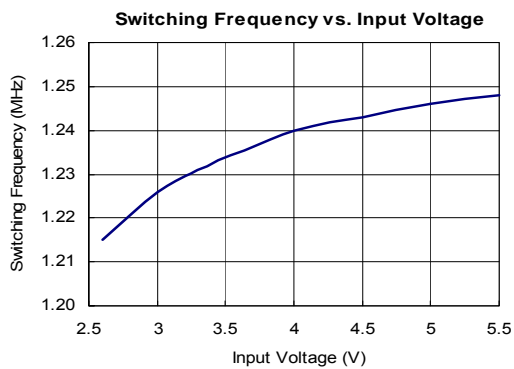
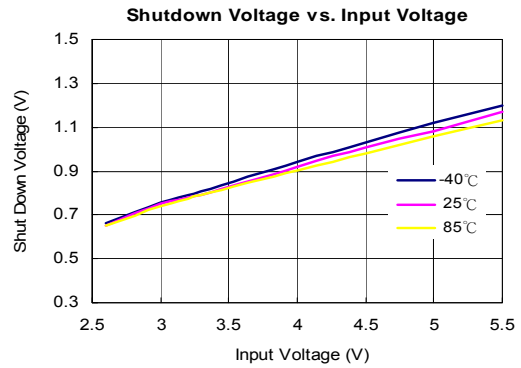
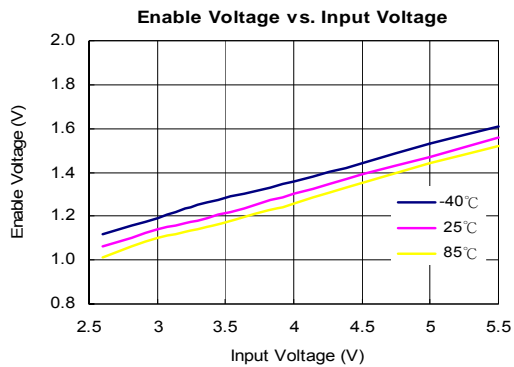

This datasheet contains new product information. Feeling Technology reserves the rights to modify the product specification without notice. No liability is assumed as a result of the use of this product. No rights under any patent accompany the sales of the product.

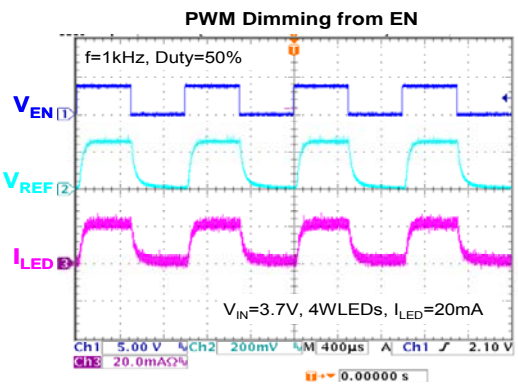
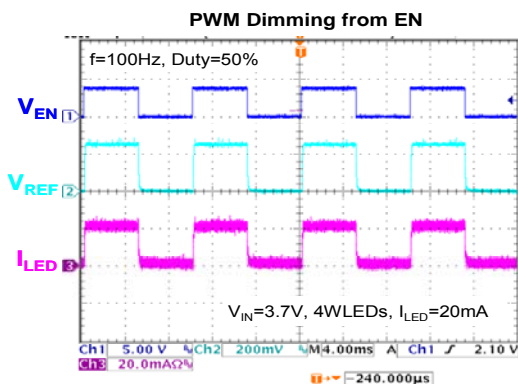
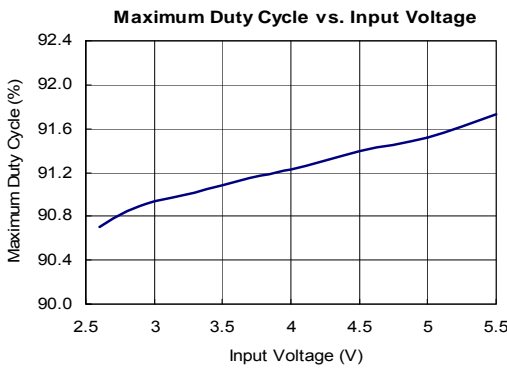
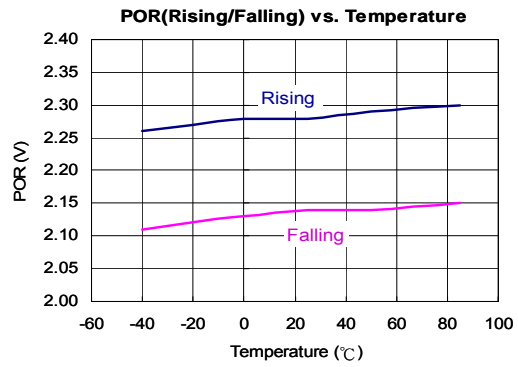
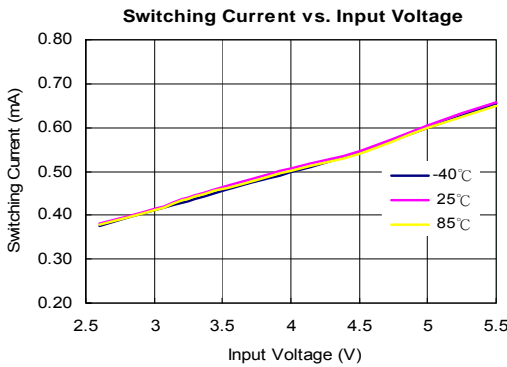
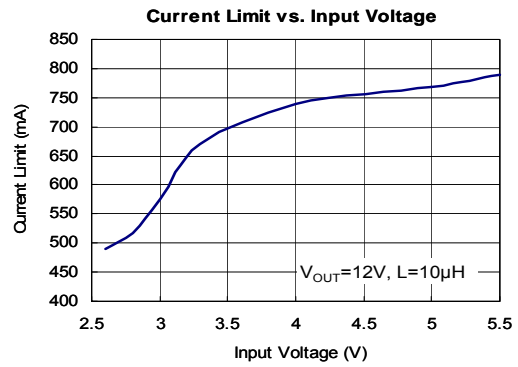
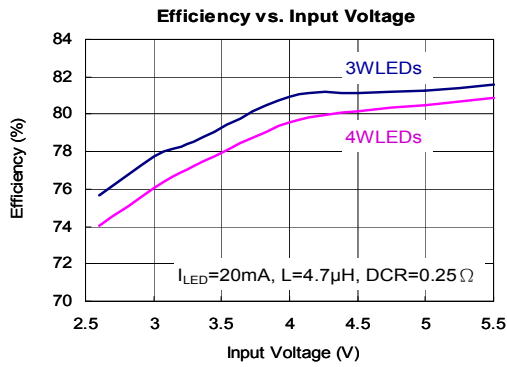

This datasheet contains new product information. Feeling Technology reserves the rights to modify the product specification without notice. No liability is assumed as a result of the use of this product. No rights under any patent accompany the sales of the product.

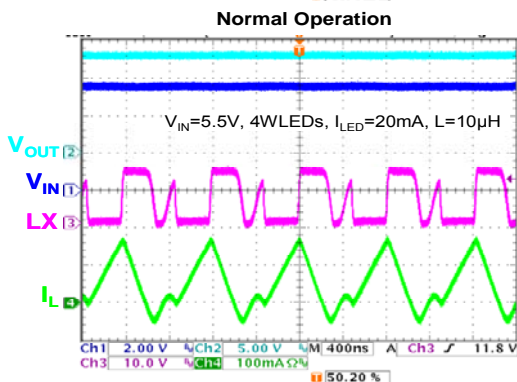
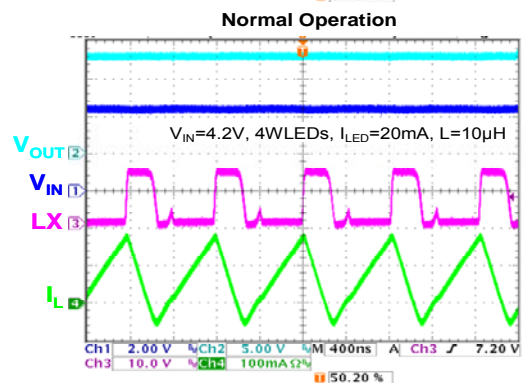
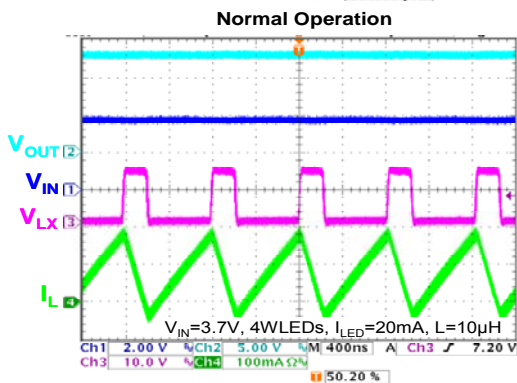
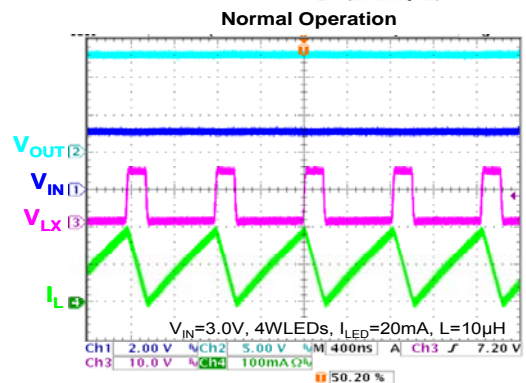
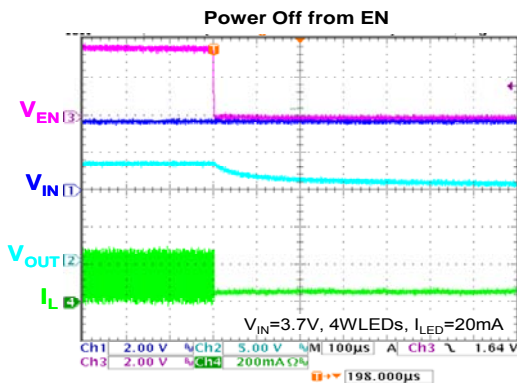
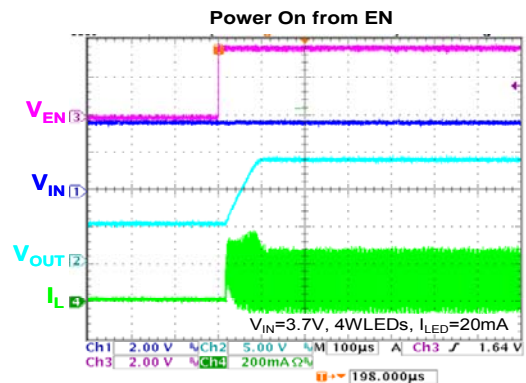
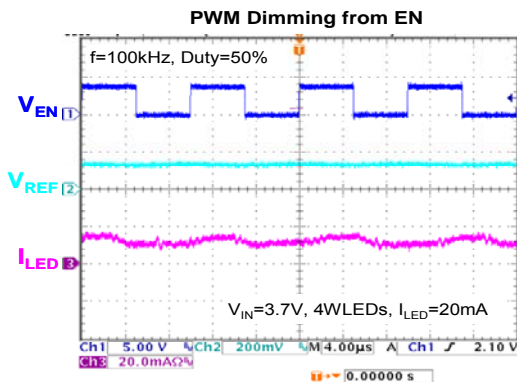

This datasheet contains new product information. Feeling Technology reserves the rights to modify the product specification without notice. No liability is assumed as a result of the use of this product. No rights under any patent accompany the sales of the product.



## Function Description

### Operation

The FP7201 is a current mode boost converter for LED driver. The constant switching frequency is 1.2MHz and operates with pulse width modulation (PWM). Build-in 27V / 0.75A MOSFET driver provides a high output voltage for 2~7 white LEDs. The control loop architecture is peak current mode control, therefore slope compensation circuit is added to the current signal to allow stable operation for duty cycles larger than 50%. The feedback reference voltage is only 0.25V, reducing the power dissipation in the current sensing resistor.

### Soft Start Function

Soft start circuitry is integrated into FP7201 to avoid inrush current during power on. After the IC is enabled, the output of error amplifier is clamped by the internal soft-start function, which causes PWM duty signal increasing slowly and thus reducing surge current.

### Over Voltage Protection (OVP)

In some condition, the WLEDs maybe fail or open, which will cause the PWM signal to operate with maximum duty cycle. The output voltage will be boosted higher and higher. When the output voltage exceeds the OVP threshold level, OVP function will turn off the power MOSFET driver immediately. The FP7201's OVP threshold is 27V.

### Over Temperature Protection (OTP)

FP7201 will turn off the power MOSFET automatically when the internal junction temperature is higher than 150°C. The power MOSFET wake up when the junction temperature drops 30°C under the OTP threshold.

## Application Information

### General Application Circuit

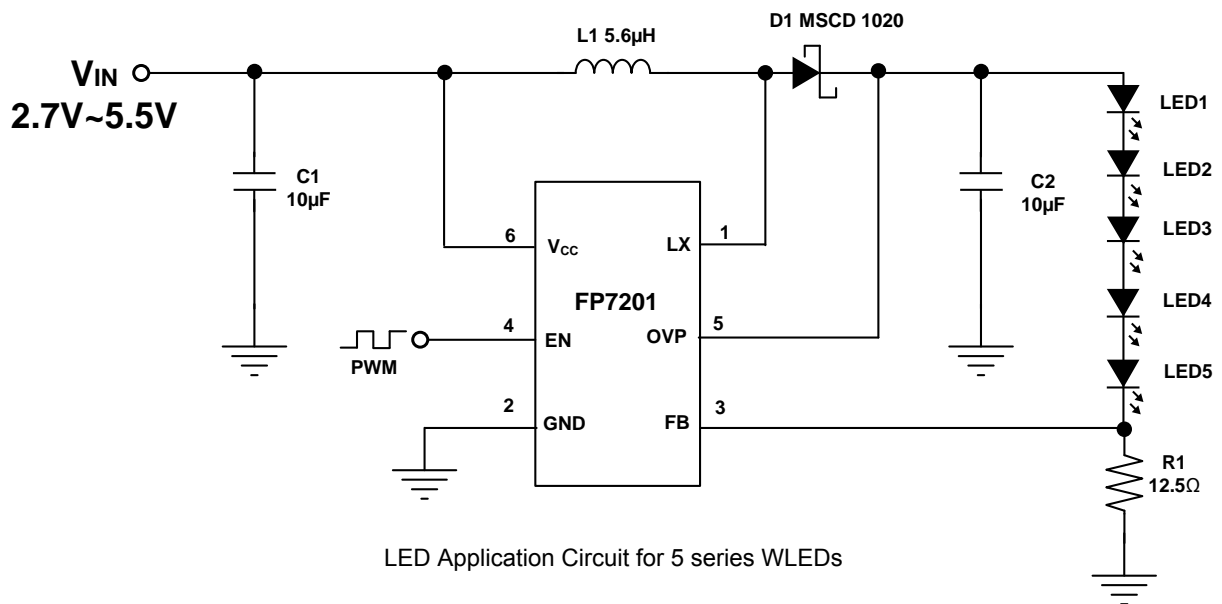
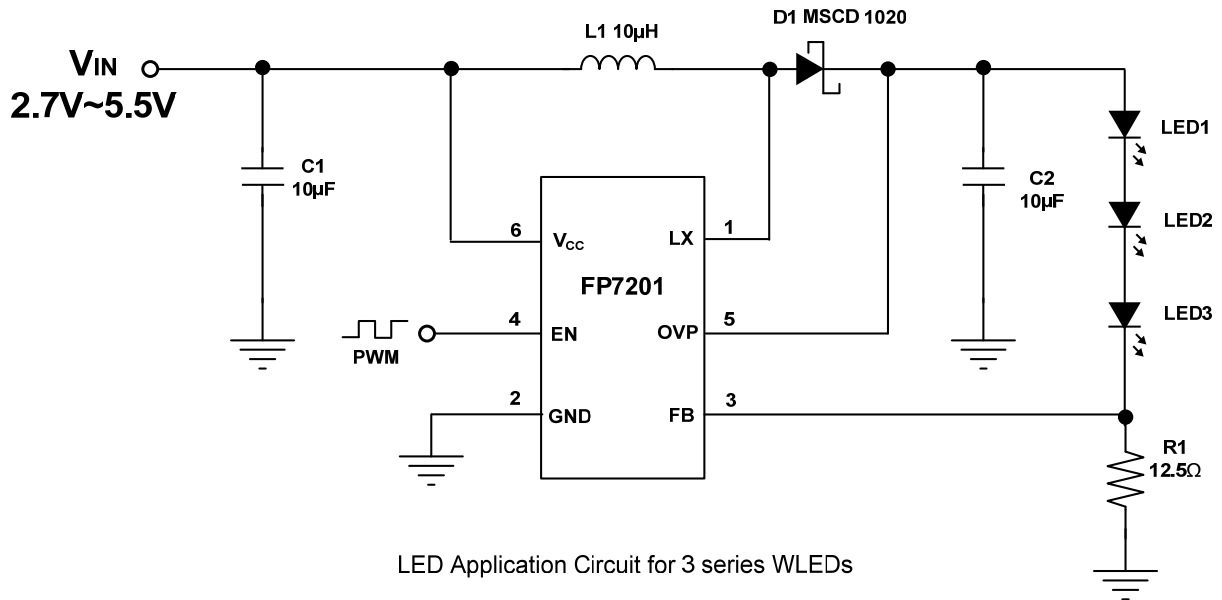

This datasheet contains new product information. Feeling Technology reserves the rights to modify the product specification without notice. No liability is assumed as a result of the use of this product. No rights under any patent accompany the sales of the product.

### Setting the LED Current

Feedback resistance R1 decides the LED current. The current through LEDs is equal to  $0.25V / R1$ . The following table shows the selection of R1 for different LED current.

$I_{LED}$  vs.  $R_1$

$I_{LED}$ (mA)	$R_1$ ( $\Omega$ )
1	250
5	50
10	25
15	16.6
20	12.5

### Dimming Control

Dimming control can adjust LED brightness. There are three ways to control LED current for the FP7201, as shown in the following.

#### a. Using the PWM Signal to EN Pin

The first way uses the PWM signal to control the Enable pin for regulating LED brightness. The LED current is between the full load to complete shutoff, and the average LED current is proportional to the PWM signal duty cycle. In addition, the PWM signal frequency should be larger than 2kHz.

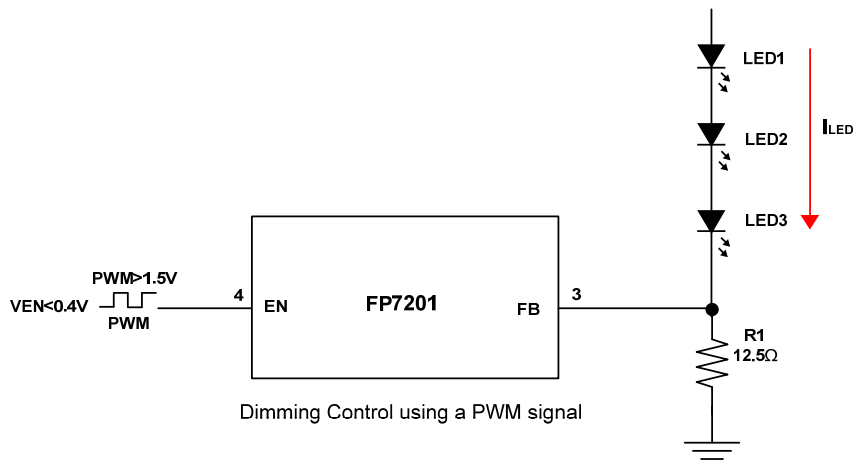

This datasheet contains new product information. Feeling Technology reserves the rights to modify the product specification without notice. No liability is assumed as a result of the use of this product. No rights under any patent accompany the sales of the product.

**b. Using a DC Voltage**

The second way uses a variable DC voltage to control the feedback voltage. When the DC voltage increases, and the circuit loop through R2 and R3 to regulate the feedback voltage. It will reduce the LED current. If the DC voltage ranges from 0V to 2.5V, the resistor values shown for R1, R2 and R3 can control the LED current from 20mA to 0mA.

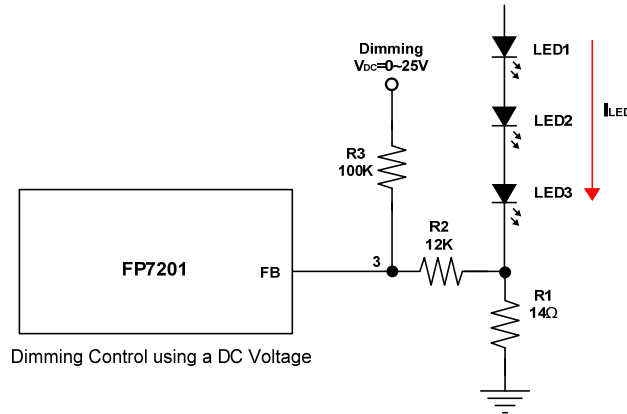

The LED current can be calculated by the following equation:

$$I_{LED} = \frac{V_{FB} - \frac{R_2 \times (V_{DC} - V_{FB})}{R_3}}{R_1}$$

**c. Using a Filtered PWM Signal**

The filtered PWM signal can be considered as an adjustable DC voltage. It can be used to replace the variable DC voltage source in dimming control. The application circuit is shown in the following.

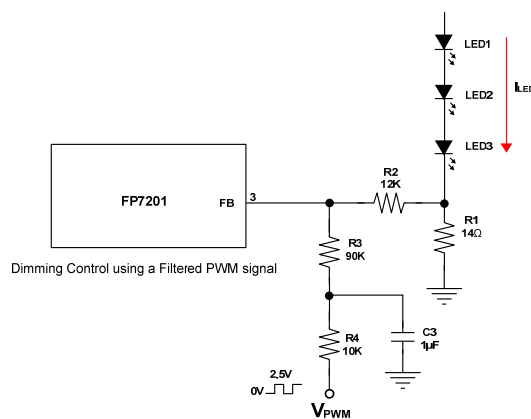

The LED current can be calculated by the following equation:

$$I_{LED} = \frac{V_{FB} - \frac{R_2 \times (V_{PWM} \times Duty - V_{FB})}{R_3 + R_4}}{R_1}$$

This datasheet contains new product information. Feeling Technology reserves the rights to modify the product specification without notice. No liability is assumed as a result of the use of this product. No rights under any patent accompany the sales of the product.

### Inductor Selection

Inductance value is decided based on different condition. 4.7 to 22 $\mu$ H inductor value is recommended for 2 to 7 WLEDs applications. There are three important inductor specifications, DC resistance, saturation current and core loss. Low DC resistance (DCR) has better power efficiency. Also, it avoids inductor saturation causing circuit system unstably and lower core loss at 1.2MHz.

### Capacitor Selection

The output capacitor is required to maintain the series LED voltage during . Low ESR capacitors are preferred to reduce the output voltage ripple. Ceramic capacitor of X5R and X7R are recommended, which have low equivalent series resistance (ESR) and wider temperature range.

### Diode Selection

Schottky diodes have fast recovery times and low forward voltages are recommended. Ensure that the diode average and peak current rating exceeds the average output current and peak inductor current. In addition, the diode's reverse breakdown voltage must exceed the open LED protection voltage.

### Layout Considerations

1. The power traces, consisting of the GND trace, the LX trace and the  $V_{CC}$  trace should be kept short, direct and wide.
2. LX · Inductance L and Diode D switching node, wide and short trace to reduce EMI.
3. Place  $C_{IN}$  near  $V_{CC}$  pin as closely as possible to maintain input voltage steady and filter out the pulsing input current.
4. Feedback resistance R must be connected to FB pin directly and as closely as possible.
5. FB is a sensitive node. Please keep it away from switching node, LX.
6. The GND of the IC,  $C_{IN}$ ,  $C_{OUT}$  should be connected close together directly to a ground plane.

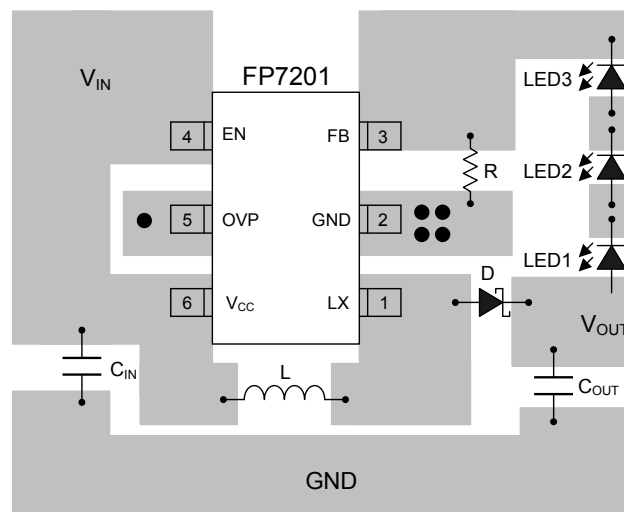

This datasheet contains new product information. Feeling Technology reserves the rights to modify the product specification without notice. No liability is assumed as a result of the use of this product. No rights under any patent accompany the sales of the product.

## Package Outline

TSOT23-6L

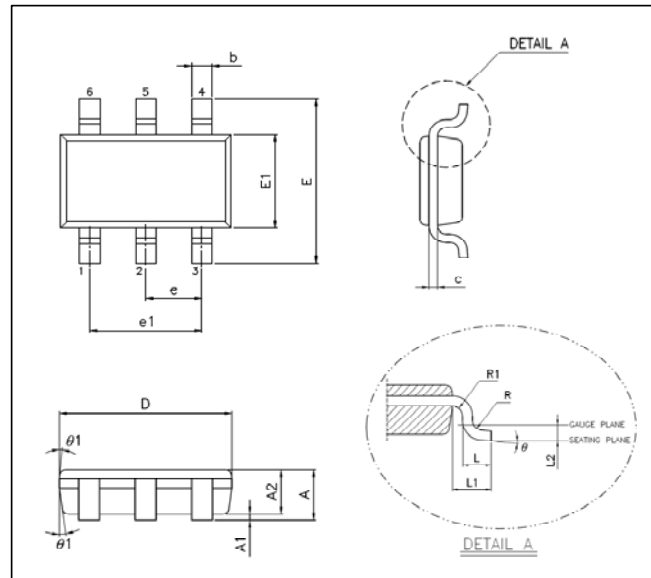

Unit: mm

Symbols	Min. (mm)	Max. (mm)
A	0.750	0.800
A1	0.000	0.050
A2	0.700	0.775
b	0.350	0.500
c	0.100	0.200
D	2.800	3.000
E	2.600	3.000
E1	1.500	1.700
e	0.950 BSC	
e1	1.900 BSC	
L	0.370	0.600
L1	0.600 REF	
L2	0.250 BSC	
R	0.100	
R1	0.100	0.250
$\theta^\circ$	0°	8°
$\theta_1$	4°	12°

### Note:

1. Dimension "D" does not include molding flash, protrusions or gate burrs.
2. Dimension "E1" does not include inter-lead flash or protrusions.

This datasheet contains new product information. Feeling Technology reserves the rights to modify the product specification without notice. No liability is assumed as a result of the use of this product. No rights under any patent accompany the sales of the product.