

Features

- * Low Forward Voltage Drop
- * High Current Capability
- * High Reliability
- * High Surge Current Capability



RoHS
COMPLIANT

Package Outline Dimensions

DO-201AD:

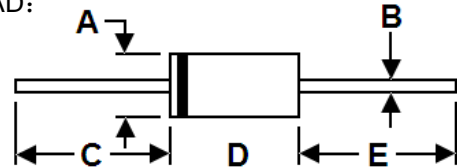

DIM.	Unit (mm)		Unit (inch)	
	Min	Max	Min	Max
A	4.8	5.3	0.189	0.209
B	1.2	1.3	0.047	0.051
C	25.4	-	1.0	-
D	7.2	9.6	0.283	0.378
E	25.4	-	1.0	-

Mechanical Data

- * Case: Molded plastic
- * Epoxy: UL 94V-0 rate flame retardant
- * Lead: Axial leads, solderable per MIL-STD-202, method 208 guaranteed
- * Polarity: Color band denotes cathode end
- * Mounting Position: Any

Maximum Ratings and Electrical Characteristics

Rating at 25 °C ambient temperature unless otherwise specified. Single phase, half wave, 60 Hz, resistive or inductive load. For capacitive load, derate current by 20%.

Type Number	Symbol	FR 301	FR 302	FR 303	FR 304	FR 305	FR 306	FR 307	Unit
Maximum Recurrent Peak Reverse Voltage	V_{RRM}	50	100	200	400	600	800	1000	V
Maximum RMS Voltage	V_{RMS}	35	70	140	280	420	560	700	V
Maximum D.C Blocking Voltage	V_{DC}	50	100	200	400	600	800	1000	V
Maximum Average Forward Rectified Current .375" (9.5mm)Lead Length @ $T_A=55^\circ C$	$I_{F(AV)}$	3.0							A
Peak Forward Surge Current, 8.3ms single half sine-wave superimposed on rated load(JEDEC method)	I_{FSM}	150							A
Maximum Instantaneous Forward Voltage at 3.0A	V_F	1.3							V
Maximum D.C Reverse Current @ $T_A=25^\circ C$ at Rated D.C Blocking Voltage @ $T_A=100^\circ C$	I_R	5.0 150							μA
Maximum Reverse Recovery Time(Note1)	T_{rr}	150			250	500		nS	
Typical Junction Capacitance(Note2)	C_J	60							pF
Operating and Storage Temperature Range	T_J/T_{STG}	-55 to +125 / -55 to +150							$^\circ C$

Note:1、 Reverse Recovery Test Conditions: $I_F=0.5A$, $I_R=1.0A$, $I_{RR}=0.25A$.

2、 Measured at 1MHz and Applied Reverse Voltage of 4.0V D.C.

Ratings and Characteristic Curves

FIG. 1 – TYPICAL FORWARD CURRENT DERATING CURVE

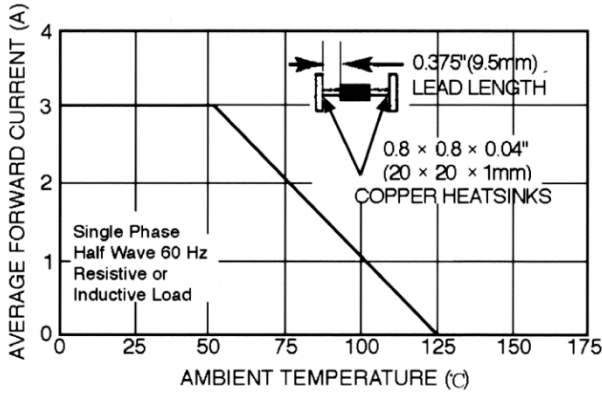

FIG. 2 – MAXIMUM NON-REPETITIVE FORWARD SURGE CURRENT

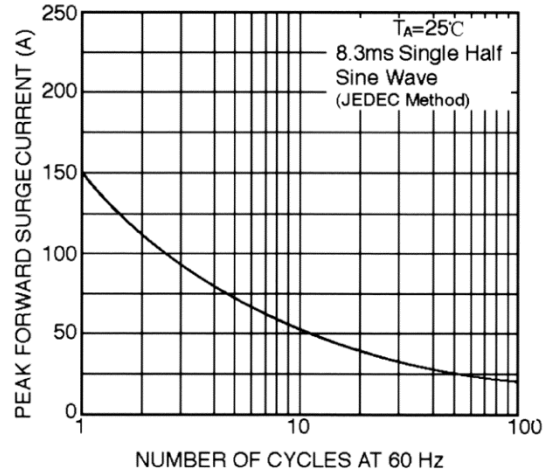

FIG. 3 – TYPICAL FORWARD CHARACTERISTICS

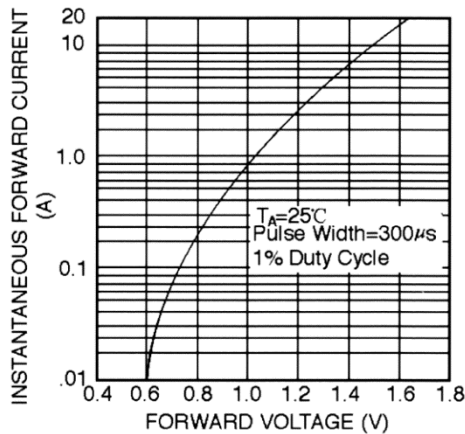

FIG. 4 – TYPICAL JUNCTION CAPACITANCE

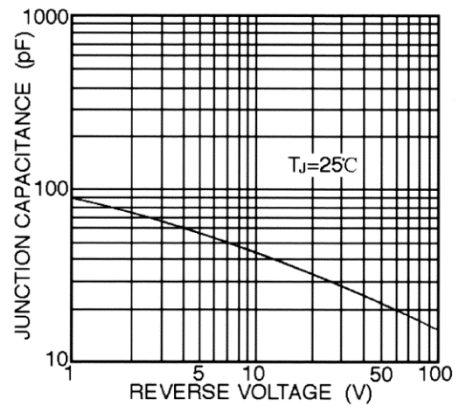
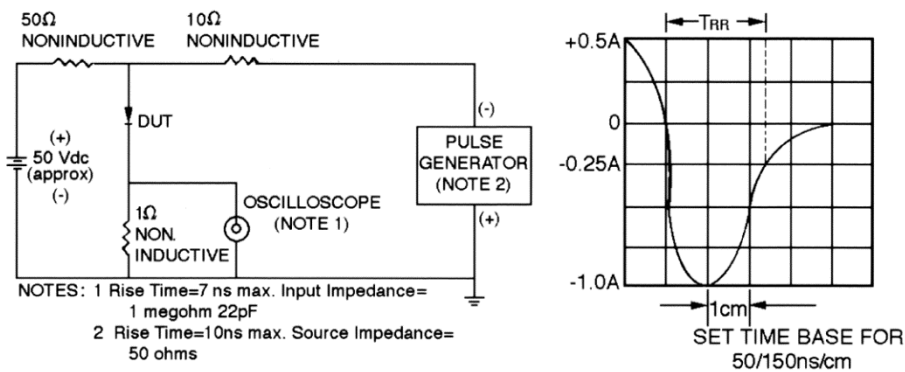

FIG. 5 – TEST CIRCUIT DIAGRAM AND REVERSE RECOVERY TIME CHARACTERISTICS





FR301 THRU FR307
3.0 Amps. Fast Recovery Rectifiers

Ordering Information

Part No.	Package	Packing
FR301~FR307	DO-201AD	0.8K/AMMO box
FR301~FR307	DO-201AD	1.2K/AMMO box
FR301~FR307	DO-201AD	1.2K/13" Paper reel
FR301~FR307	DO-201AD	0.5K/Bulk packing